

# DISPLAY THIS CARD ON PRINCIPAL FRONTAGE OF WORK CITY OF PORTLAND

## BUILDING INSPECTION PERMIT

Permit Number: 031053

Please Read Application And Notes, if Any, Attached

This is to certify that October Corporation / PL Wilkins  
has permission to Install an ATM Machine on Existing Lot  
AT 401 Fore St 032 1041001

provided that the person or persons, firm or corporation accepting this permit shall comply with all of the provisions of the Statutes of Maine and of the Ordinances of the City of Portland regulating the construction, maintenance and use of buildings and structures, and of the application on file in this department.

Apply to Public Works for street line and grade if nature of work requires such information.

Notification of inspection must be given and when permission is procured before this building or part thereof is occupied or otherwise closed-in.  
HOURS NOT REQUIRED.

A certificate of occupancy must be procured by owner before this building or part thereof is occupied.

### OTHER REQUIRED APPROVALS

Fire Dept. [Signature]  
Health Dept. \_\_\_\_\_  
Appeal Board \_\_\_\_\_  
Other \_\_\_\_\_  
Department Name \_\_\_\_\_

[Signature] 9/13/03  
Director - Building & Inspection Services

**PENALTY FOR REMOVING THIS CARD**

**City of Portland, Maine - Building or Use Permit Application**  
 389 Congress Street, 04101 Tel: (207) 874-8703, Fax: (207) 874-8716

Permit No: 03-1053	Issue Date:	CEI: 032 I041001
-----------------------	-------------	---------------------

Location of Construction: 401 Fore St	Owner Name: October Corporation	Owner Address: One Canal Plaza	Phone:
Business Name:	Contractor Name: PL Williams	Contractor Address: 405 Western Avenue South Portland	Phone: 2076500389
Lessee/Buyer's Name	Phone:	Permit Type: Additions - Commercial	Zone: B3

Fast Use: Parking Lot/Commercial	Proposed Use: Parking Lot w/ATM Machine	Permit Fee: \$111.00	Cost of Work: \$10,000.00	CEO District: 1
		FIRE DEPT: <input checked="" type="checkbox"/> Approved <input type="checkbox"/> Denied	INSPECTION: Use Group: B Type: 2B 9/3/03	

Proposed Project Description:  
Install an ATM Machine on Parking Lot

Signature: *[Handwritten Signature]* Signature: *[Handwritten Signature]*

PEDESTRIAN ACTIVITIES DISTRICT (P.A.D.)

Action:  Approved  Approved w/Conditions  Denied

Signature: \_\_\_\_\_ Date: \_\_\_\_\_

Permit Taken By: gad	Date Applied For: 08/27/2003	<b>Zoning Approval</b>	
-------------------------	---------------------------------	------------------------	--

1. This permit application does not preclude the Applicant(s) from meeting applicable State and Federal Rules. 2. Building permits do not include plumbing, septic or electrical work. 3. Building permits are void if work is not started within six (6) months of the date of issuance. False information may invalidate a building permit and stop all work..	Special Zone or Reviews <input type="checkbox"/> Shoreland <input type="checkbox"/> Wetland <input type="checkbox"/> Flood Zone <input type="checkbox"/> Subdivision <input type="checkbox"/> Site Plan <i>study exemption applies for</i> Maj <input type="checkbox"/> Minor <input type="checkbox"/> MM <input type="checkbox"/> Date: <i>9/29/03</i>	Zoning Appeal <input type="checkbox"/> Variance <input type="checkbox"/> Miscellaneous <input type="checkbox"/> Conditional Use <input type="checkbox"/> Interpretation <input type="checkbox"/> Approved <input type="checkbox"/> Denied Date: _____	Historic Preservation <input checked="" type="checkbox"/> Not in District or Landmark <input checked="" type="checkbox"/> Does Not Require Review <input type="checkbox"/> Requires Review <input type="checkbox"/> Approved <input type="checkbox"/> Approved w/Conditions <input type="checkbox"/> Denied TO D.A. <i>9/2/03</i> Date: _____
--	--	--	---

*D. Andrews*  
*9/2/03*

**CERTIFICATION**

I hereby certify that I am the owner of record of the named property, or that the proposed work is authorized by the owner of record and that I have been authorized by the owner to make this application as his authorized agent and I agree to conform to all applicable laws of this jurisdiction. In addition, if a permit for work described in the application is issued, I certify that the code official's authorized representative shall have the authority to enter all areas covered by such permit at any reasonable hour to enforce the provision of the code(s) applicable to such permit.

\_\_\_\_\_  
SIGNATURE OF APPLICANT ADDRESS DATE PHONE

\_\_\_\_\_  
RESPONSIBLE PERSON IN CHARGE OF WORK, TITLE DATE PHONE

**PL WILLIAMS AND COMPANY****ATM and Bank Equipment Construction**

405 Western Avenue South Portland, ME 04106 Voice 207.650.0389 Efax 309.279.7412 Fax 207.871.0186 Email plwilliamsandco@aol.com

August 26, 2003

Building Inspection Department  
City of Portland  
389 Congress Street  
Portland, ME.

The attached information is being submitted on behalf of Peoples Heritage Bank, and Banknorth Group, in application for a Building Permit to install a Free Standing Walk UP ATM at the Fore Street Parking Garage, in Portland, ME.

Peoples Heritage Bank is requesting the permit to install a Diebold 1075ix Walk Up ATM in the location shown in the enclosed photographs.

The ATM would replace the former ATM location on Middle Street that Peoples Heritage Bank will no longer operate, and is intended to provide convenience to their customers in the Old Port area.

The Scope of Work for the project is as follows;

Alterations to existing chain link fence to create an area approximately 95" wide by 101" deep for the ATM, and the area for customers to access and use the ATM.

Installation of new fencing on the back of the ATM, above the ATM, and to the right of the ATM to prevent access to the Parking Garage, during the hours the garage is closed.

Installation of a floating concrete pad approximately 95" wide by 101" deep, to locate the ATM, and to create ADA Compliant access to the ATM.

Installation of an Awning over the ATM, as Proposed under separate permit application by Leavitt and Paris Inc.

Installation of the Diebold 1075ix with a self contained Topper to house Alarm Equipment, CCTV Equipment, and the TCIP Data Equipment required to operate the ATM.

Installation of an additional approach or area Closed Circuit Camera to monitor activity in the area around the ATM.

This package contains the following information for review:

Color photographs of the proposed site, and surrounding area.

Plan View sketch of the area at and around the ATM showing the proposed layout, and anticipated fence alterations.

Site Prep information for a Diebold 1075ix ATM.

Contact Information:

The following contact information is being provided in the event there are questions concerning any aspect of the project:

**Property Manager**

Rod Geant  
Transaction Manager  
C.B. Richard Ells- Boulos Property Management  
One Canal Plaza  
Portland, ME. 04101  
Voice 207.871.1296  
Email [rgeant@boulos.com](mailto:rgeant@boulos.com)

**Peoples Heritage Bank**

**Electronic Banking**

Ms. Christy Morgan  
Banknorth, N.A.  
Electronic Banking  
ATM Hardware Specialist  
Phone - (207) 755-6207  
Fax - (207) 753-5982  
Mailstop: ME034-33  
Email [cmorgan@banknorth.com](mailto:cmorgan@banknorth.com)

**Facilities**

Ms.Emily Clark  
Sr. Facilities Manager  
70 Gray Road  
Falmouth, ME. 04105  
Voice 207.317.5103  
Email [eclark@banknorth.com](mailto:eclark@banknorth.com)

**Project Management**

Peter Williams  
PL Williams and Company  
405 Western Avenue  
South Portland, ME. 04106  
Voice 207.650.0389  
Email [pwilliamsandco@aol.com](mailto:pwilliamsandco@aol.com)

Respectfully submitted,

Peter Williams  
PL Williams and Company

PLAN VIEW  
PROPOSED BANKNORTH ATM  
FORE STREET PARKING GARAGE  
PORTLAND, ME.

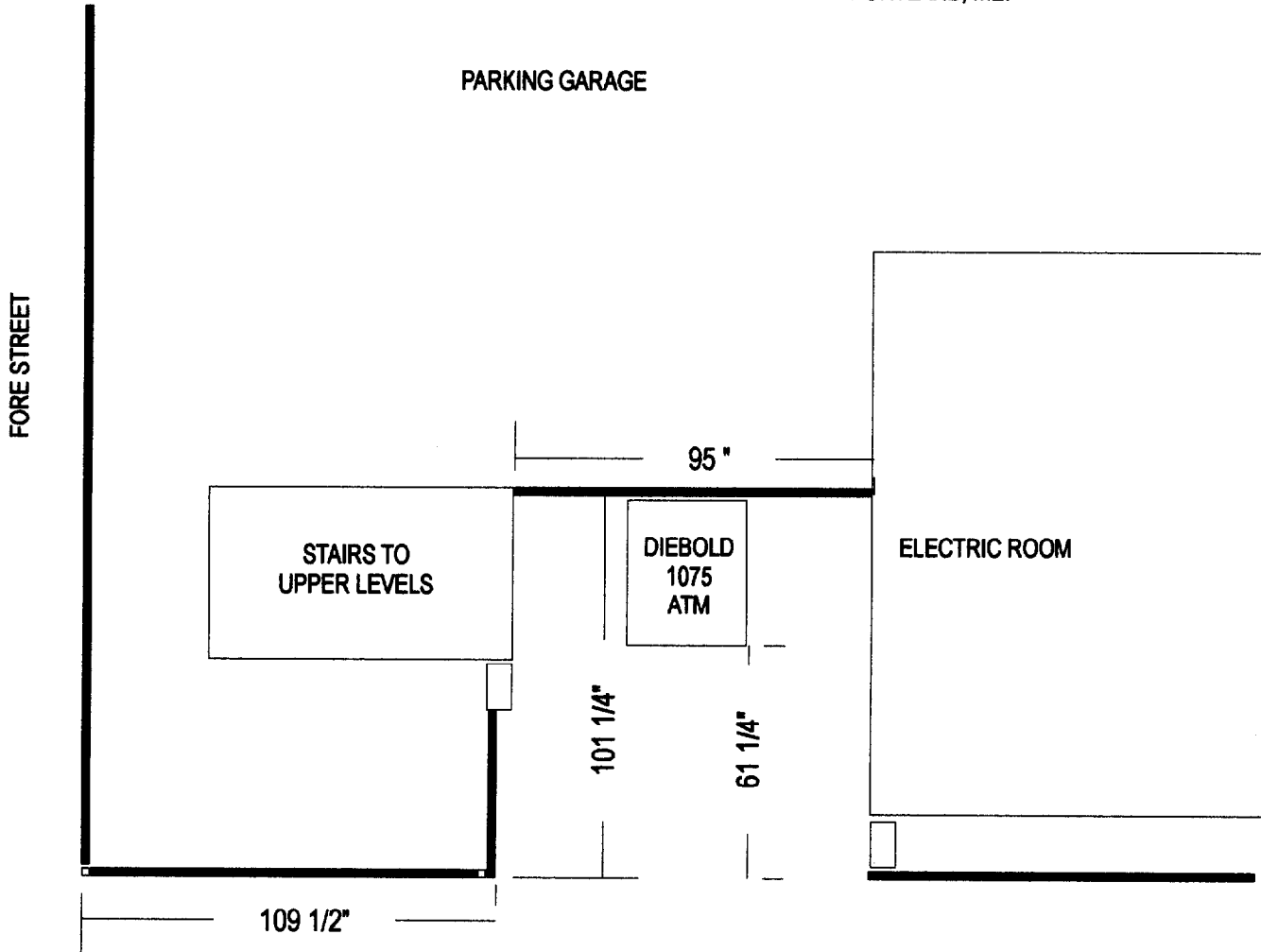

EXISTING CHAIN LINK FENCE 

NEW CHAIN LINK FENCE 

ALL DIMENSIONS ARE APPROXIMATE AND WILL BE VERIFIED IN THE FIELD

03-1053

# All Purpose Building Permit Application

If you or the property owner owes real estate or personal property taxes or user charges on any property within the City, payment arrangements must be made before permits of any kind are accepted.

~~404~~ 401-421 Fore St.

Location/Address of Construction: <del>404</del> FORE ST, PORTLAND, ME 04101		
Total Square Footage of Proposed Structure		Square Footage of Lot
Tax Assessor's Chart, Block & Lot Chart# 032 Block# I Lot# 041	Owner: October Corporation One Canal Plaza	Telephone:
Lessee/Buyer's Name (If Applicable) PEOPLES HERITAGE BANK BANKNORTH GROUP	Applicant name, address & telephone: PETER WILLIAMS 405 WESTERN AVE SOUTH PORTLAND, ME 04106 207-650-0389	Cost Of Work: \$ 10,000.00 Fee: \$ 111.00
Current use: <u>Parking Lot</u>		
If the location is currently vacant, what was prior use: <u>LOCATED IN EXISTING PARKING GARAGE</u>		
Approximately how long has it been vacant: _____		
Proposed use: <u>WALK UP ATM</u>		
Project description: <u>Parking lot w/ ATM</u>		
Contractor's name, address & telephone: <u>PL WILLIAMS AND CO 405 WESTERN AVE SOUTH PORTLAND ME 04106</u>		
Who should we contact when the permit is ready: <u>PETER WILLIAMS 207-650-0389</u>		
Mailing address: <u>207-650-0389</u> <span style="float: right;"><u>Excel</u></span>		
We will contact you by phone when the permit is ready. You must come in and pick up the permit and review the requirements before starting any work, with a Plan Reviewer. A stop work order will be issued and a \$100.00 fee if any work starts before the permit is picked up. PHONE: <u>207-650-0389</u>		

IF THE REQUIRED INFORMATION IS NOT INCLUDED IN THE SUBMISSIONS THE PERMIT WILL BE AUTOMATICALLY DENIED AT THE DISCRETION OF THE BUILDING/PLANNING DEPARTMENT, WE MAY REQUIRE ADDITIONAL INFORMATION IN ORDER TO APPROVE THIS PERMIT.

I hereby certify that I am the Owner of record of the named property, or that the owner of record authorizes the proposed work and that I have been authorized by the owner to make this application as his/her authorized agent. I agree to conform to all applicable laws of this jurisdiction. In addition, if a permit for work described in this application is issued, I certify that the Code Official's authorized representative shall have the authority to enter all areas covered by this permit at any reasonable hour to enforce the provisions of the codes applicable to this permit.

Signature of applicant: <u>Peter Williams</u>	Date: <u>8/27/03</u>
---	----------------------

This is NOT a permit, you may not commence ANY work until the permit is issued. If you are in a Historic District you may be subject to additional permitting and fees with the Planning Department on the 4th floor of City Hall

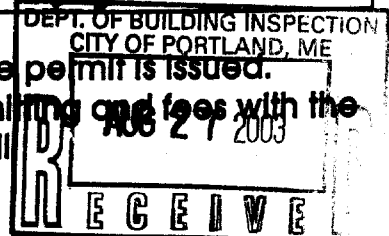

L375417

CALL 1-800-999-3600

DIMENSIONS IN MILLIMETRES  
(DIMENSIONS IN INCHES)

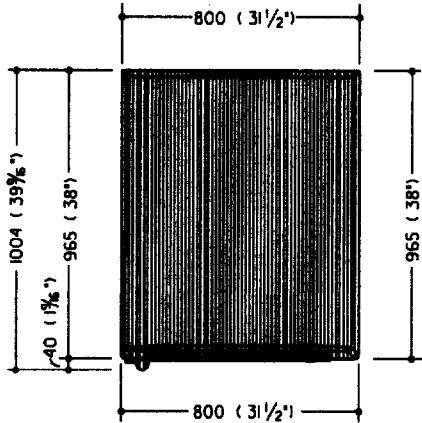

PLAN VIEW

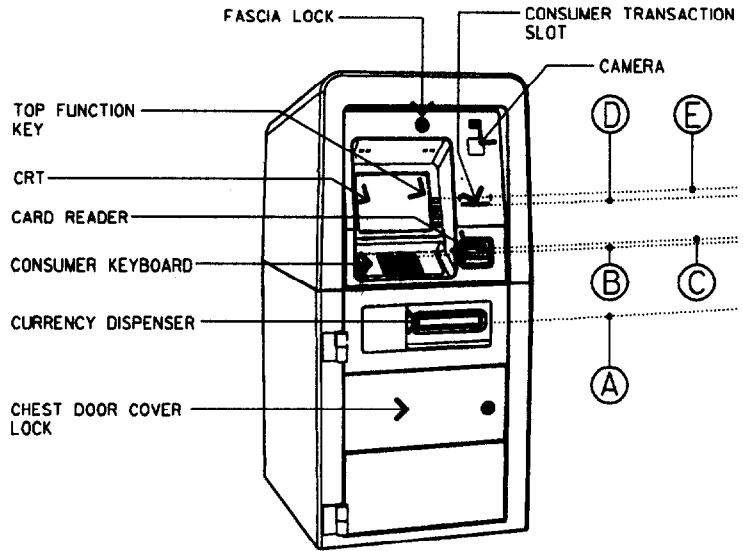

PERSPECTIVE

	CURRENCY DISPENSER Ⓐ	CONSUMER KEYBOARD Ⓑ	CARD READER Ⓒ	CONSUMER TRANSACTION SLOT Ⓓ	TOP FUNCTION KEY Ⓔ
HEIGHT FROM BOTTOM OF SAFE	779 (30 5/8")	1008 (39 5/8")	1041 (41")	1206 (47 1/2")	1203 (47 3/8")
DEPTH FROM FRONT EDGE OF SAFE	13 (1/2")	98 (3 7/8")	57 (2 1/4")	25 (1")	152 (6")

PAGE 1 OF 4

ALL DIMENSIONS AND DESIGN CRITERIA  
SUBJECT TO CHANGE WITHOUT NOTICE.

FILE NO. 177-417 REV. 2

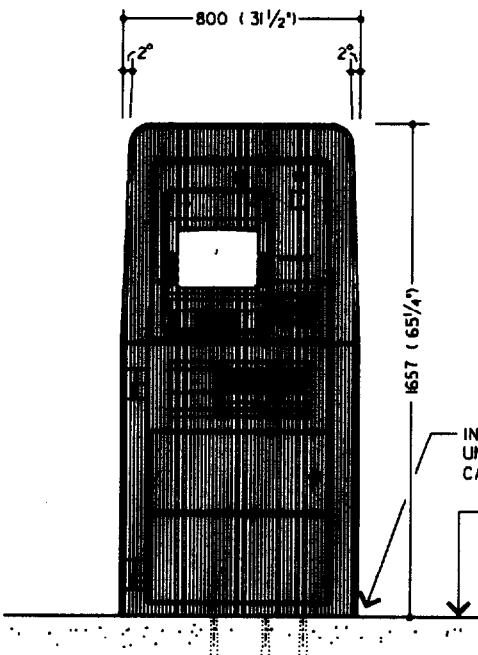

FRONT ELEVATION

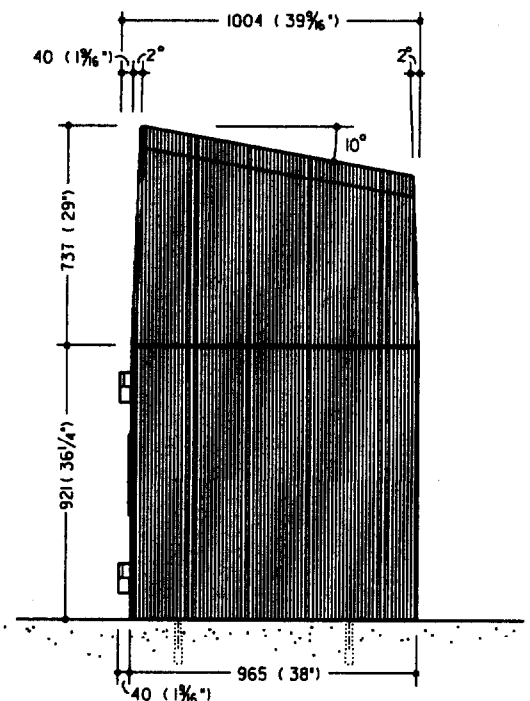

SIDE ELEVATION

INSTALLER TO SET LEVEL, SECURE  
UNIT TO CONCRETE SURFACE AND  
CAULK AROUND UNIT

CONCRETE SURFACE TO BE  
FLAT AND LEVEL IN AREA OF  
UNIT

ANCHORS AS REQUIRED  
(SEE BACK PAGE FOR LOCATION)



### PHYSICAL SECURITY

THE SAFE MEETS THE REQUIREMENTS OF UL STANDARD 29 LEVEL 2 FOR AUTOMATED TELLER SYSTEMS FOR 24 HOUR SERVICE. THE SAFE DOOR IS PROVIDED WITH UL LISTED RELOCKING DEVICES AND A UL LISTED GROUP 1 MECHANICAL COMBINATION LOCK, OR OPTIONAL UL LISTED ELECTRICAL LOCKS.

TO MEET REQUIREMENTS OF UL 29 THE UNIT MUST BE ANCHORED TO A CONCRETE PAD OF 152mm (6") MIN. THICKNESS USING THE ANCHORS PROVIDED

### POWER REQUIREMENTS

THE ATM REQUIRES SINGLE-PHASE THREE-WIRE UNSWITCHED POWER. WIRING TO THE ATM MUST USE A THIRD-WIRE EARTH GROUND (CONDUIT GROUND IS NOT ACCEPTABLE). THE POWER SUPPLIED MUST BE AS SPECIFIED BELOW:

- 100-127 VAC (+6%,-10%) 50Hz (+/-1%) SINGLE PHASE
- 100-127 VAC (+6%,-10%) 60Hz (+/-1%) SINGLE PHASE
- 200-240 VAC (+/-10%) 50Hz (+/-1%) SINGLE PHASE
- 200-240 VAC (+/-10%) 60Hz (+/-1%) SINGLE PHASE

POWER TO THE ATM MAY BE A BRANCH OR DEDICATED SERVICE AND MUST BE PROTECTED BY A SAFETY QUICK-DISCONNECT DEVICE TO BREAK LINE VOLTAGE (SUCH AS A CIRCUIT BREAKER AT THE ELECTRICAL SERVICE PANEL). THE QUICK DISCONNECT DEVICE (OR CIRCUIT BREAKER) MUST TURN OFF THE LINE VOLTAGE AT THE AMPERAGE SPECIFIED BELOW.

- 100-127 VAC SERVICE, DISCONNECT AT 20 AMPERES SHARED \*/ 15 AMPERES DEDICATED
- 200-240 VAC SERVICE, DISCONNECT AT 10 AMPERES

\* OTHER ELECTRONIC DEVICES SHARING POWER ON A COMMON BRANCH CIRCUIT MUST CONFORM TO THE SAME CONDUCTED INTERFERENCE STANDARDS AS THE ATM.

### POWER USAGE

MACHINE STATUS	① SYSTEM CONFIGURATION	② MAXIMUM CONFIGURATION
IDLE (NO TRANSACTION)	195 WATTS	1145 WATTS
TRANSACTION (DISPENSE) IN PROGRESS	295 WATTS	1245 WATTS

- ① CTP OR HTP PROCESSOR, MONO OR COLOR MONITOR, MOTORIZED CARD READER, JOURNAL PRINTER, THERMAL CONSUMER PRINTER, PRESIDER ALARM, FOUR-HIGH DISPENSER AND FASCIA LITE.
  - ② SAME AS (1) ABOVE WITH HEATERS AND SIGNAGE ENABLED.
- THE POWER USE DEPENDS ON THE NUMBER AND TYPE OF DEVICES PRESENT IN THE ATM, AND THE TYPE OF TRANSACTION THE ATM IS PERFORMING.

### HEAT OUTPUT

- 665 BTU/HR WITHOUT HEATERS (IDLE)
- 3,566 BTU/HR WITH HEATERS (IDLE)
- 3,907 BTU/HR WITH HEATERS (DISPENSE)

### OPERATING ENVIRONMENT

-34° C TO 49° C (-30° F TO 120° F) WITHOUT SUN EXPOSURE. 15% TO 100% RELATIVE HUMIDITY. CANOPY RECOMMENDED.

### CANOPY REQUIREMENT

IT IS RECOMMENDED THE UNIT BE PLACED UNDER COVER/CANOPY FOR OPERATOR/SERVICE PROTECTION.

### WEIGHT OF UNIT

1,364 kg (3,000 LBS.)

### ALARM PROTECTION

THE UL-LISTED SAFE IS EQUIPPED WITH A BASIC ALARM SENSOR PACKAGE. THE BASIC PACKAGE INCLUDES A SAFE DOOR OPEN SWITCH, ALARM SHUNTING SWITCH, AND RATE-OF-RISE HEAT SENSOR.

DIMENSIONS IN MILLIMETRES  
(DIMENSIONS IN INCHES)



PAGE 2 OF 4

ALL DIMENSIONS AND DESIGN CRITERIA  
SUBJECT TO CHANGE WITHOUT NOTICE.

FILE NO. 177-417 REV. 2

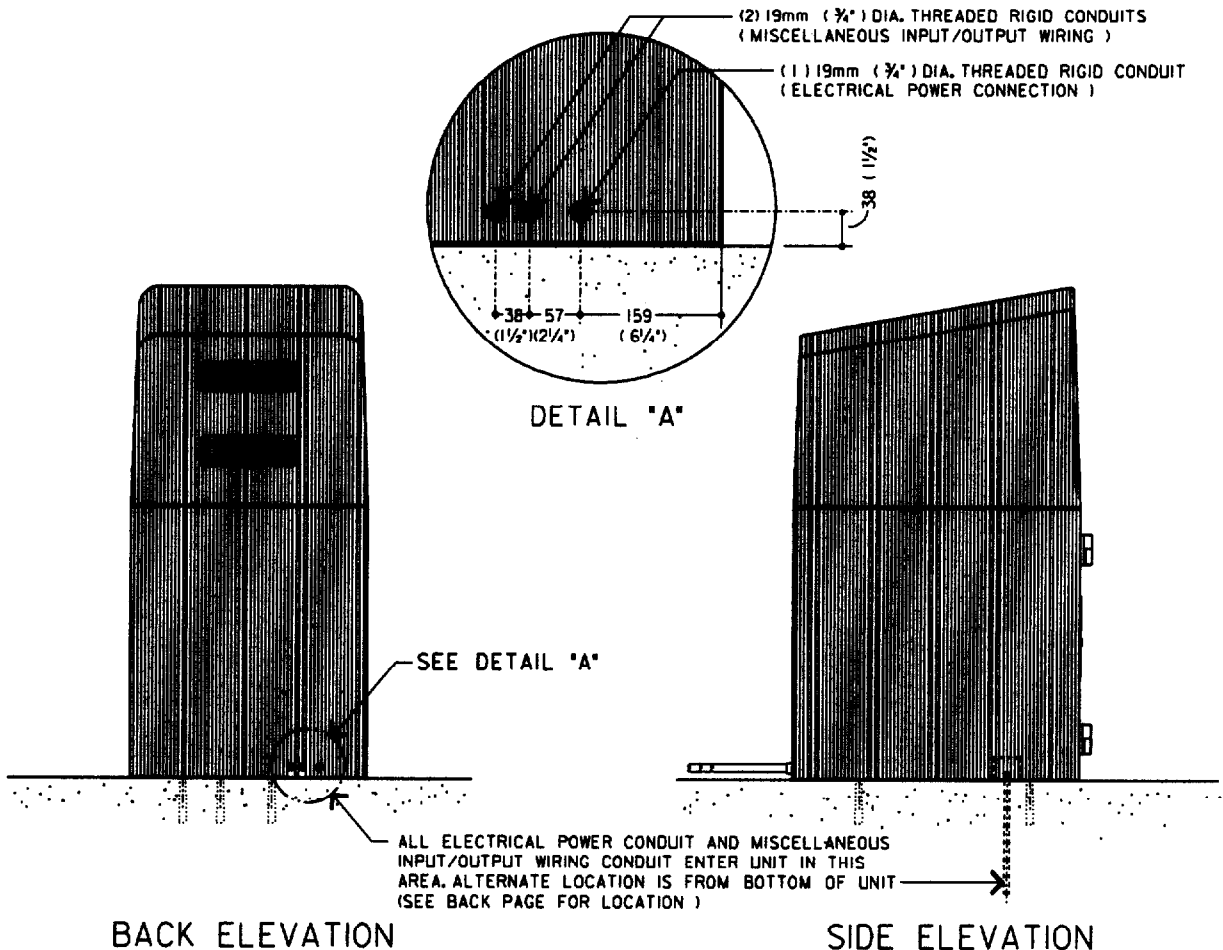





10751x OPTIONAL SIGNAGE PANEL



DIMENSIONS IN MILLIMETRES  
(DIMENSIONS IN INCHES)

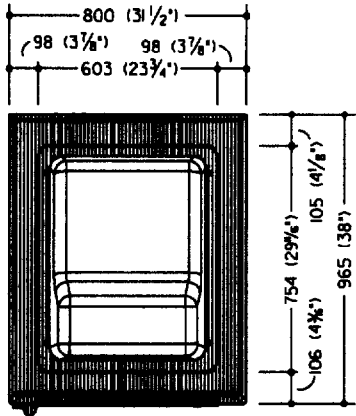

PLAN VIEW

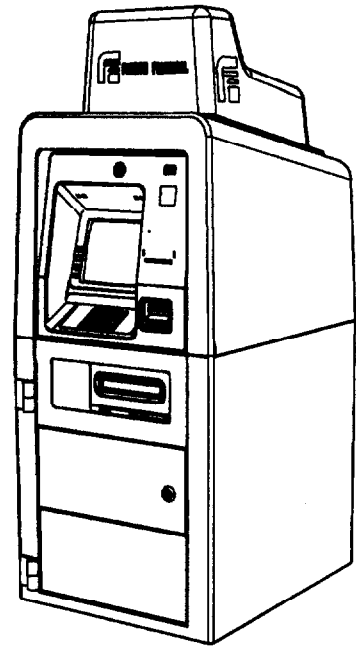

PERSPECTIVE

\*ALL DIMENSIONS AND DESIGN CRITERIA  
SUBJECT TO CHANGE WITHOUT NOTICE.\*

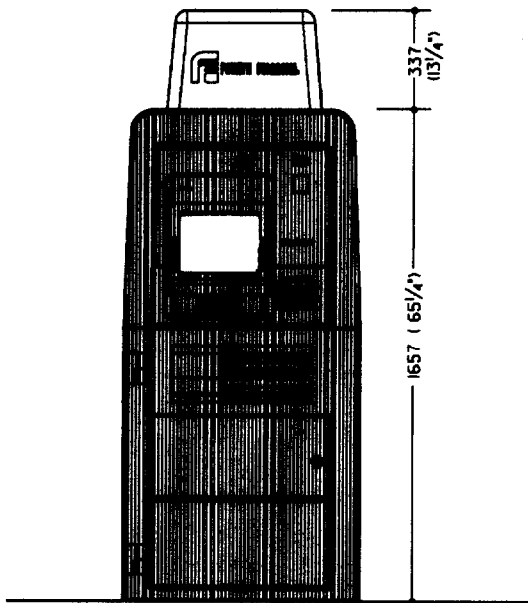

FRONT ELEVATION

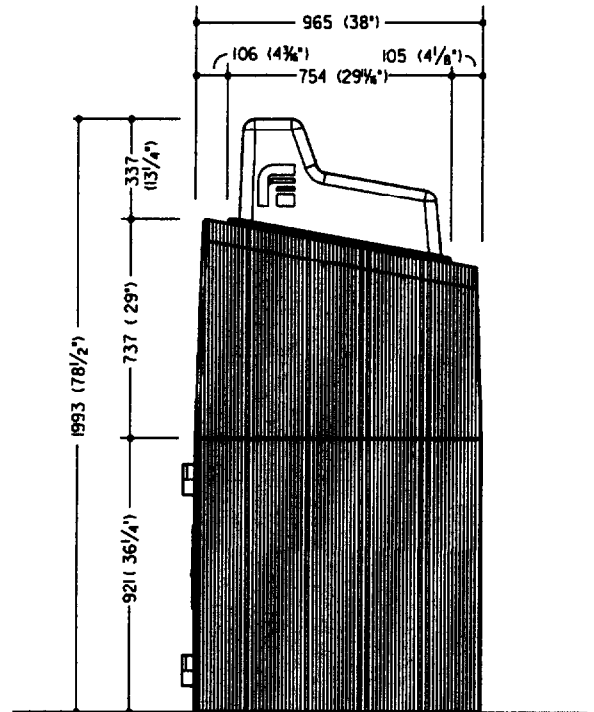

SIDE ELEVATION

8/17/04

done

or