

Mark	Date	Description
		Project Status
		<b>ISSUED FOR CONSTRUCTION</b>
		03-01-2013
		Drawing Title
		<b>INTERIOR ELEVATIONS    PUBLIC AREAS</b>
		Scale: 1/4" = 1'-0"
		Drawing Number

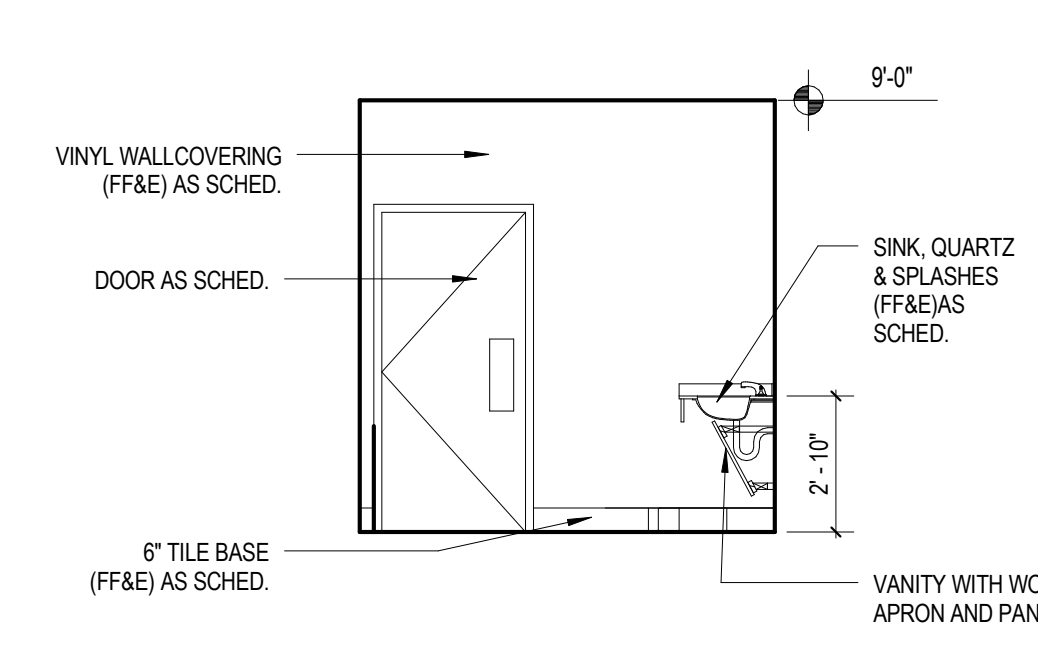

**01** INTERIOR ELEVATION @  
 WOMEN'S RESTROOM 227  
 1/4" = 1'-0"

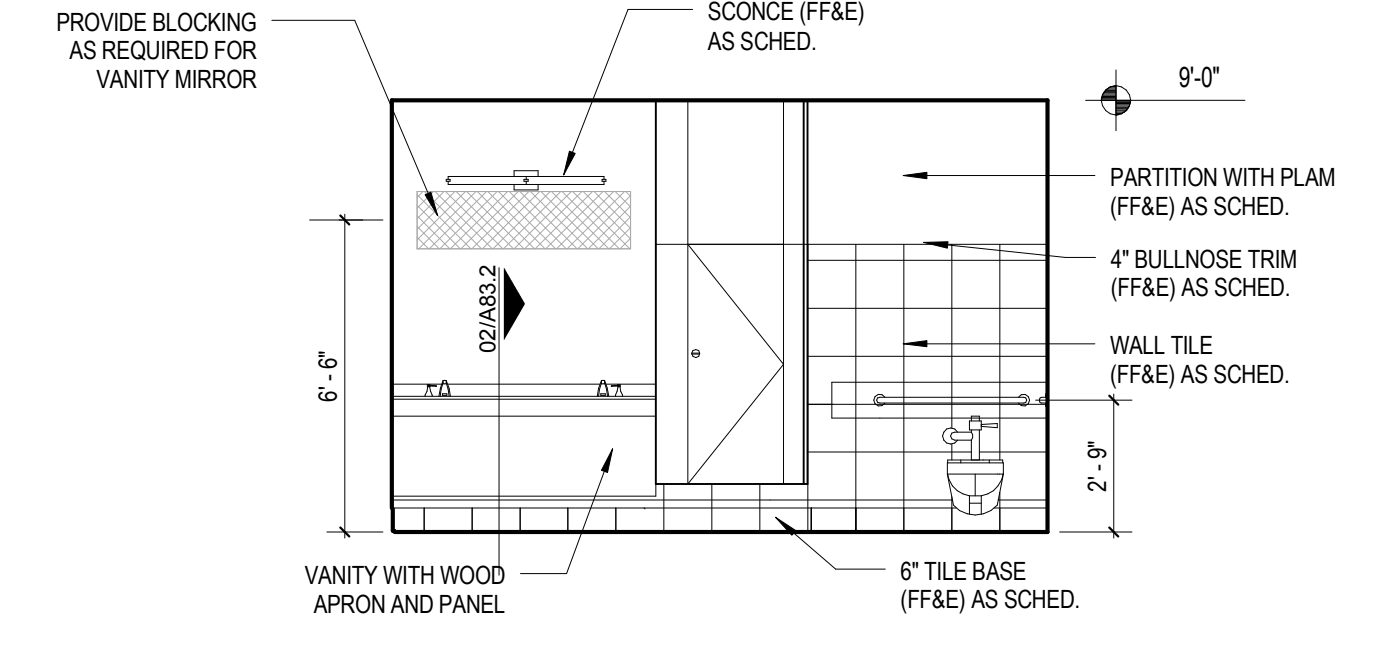

**02** INTERIOR ELEVATION @  
 WOMEN'S RESTROOM 227  
 1/4" = 1'-0"

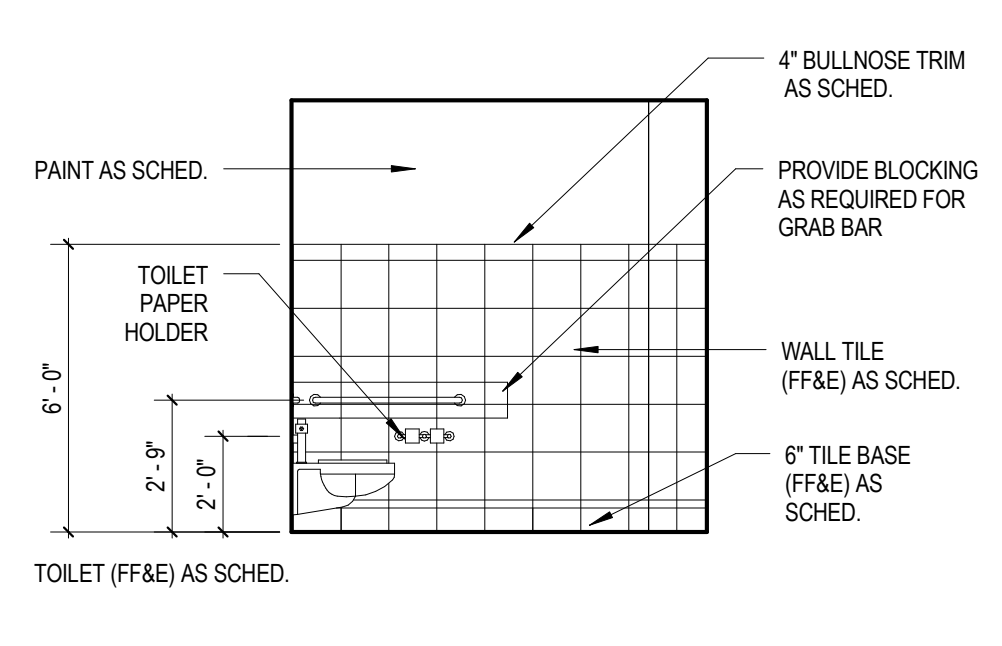

**03** INTERIOR ELEVATION @  
 WOMEN'S RESTROOM 227  
 1/4" = 1'-0"

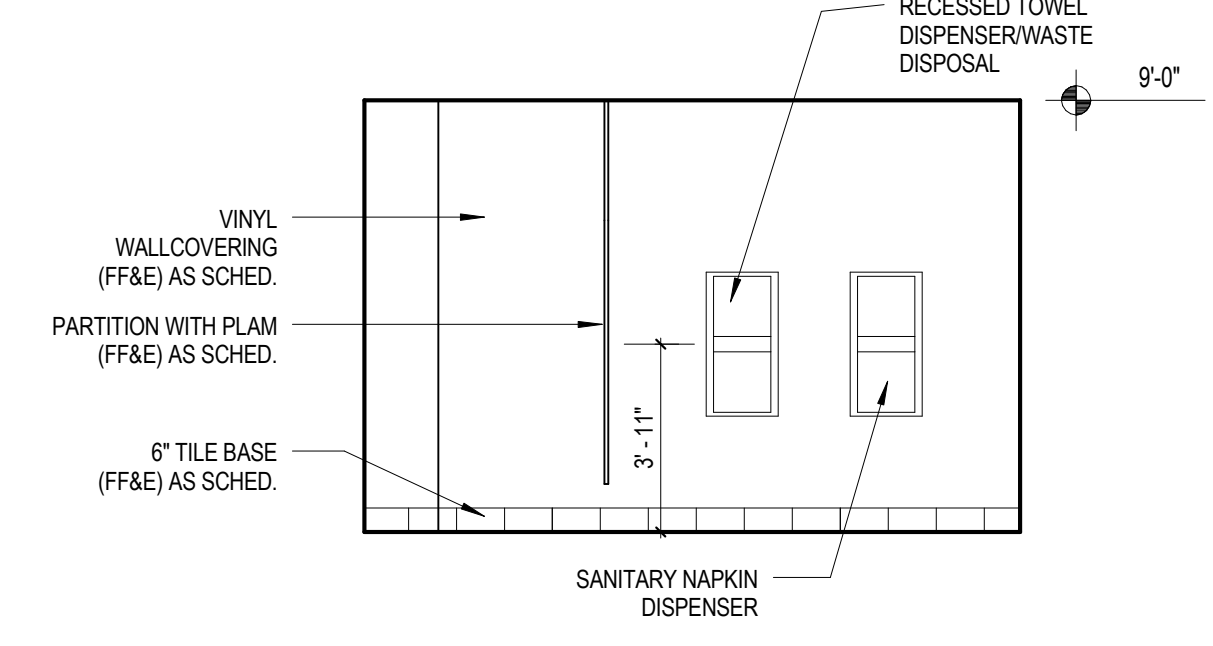

**04** INTERIOR ELEVATION @  
 WOMEN'S RESTROOM 227  
 1/4" = 1'-0"

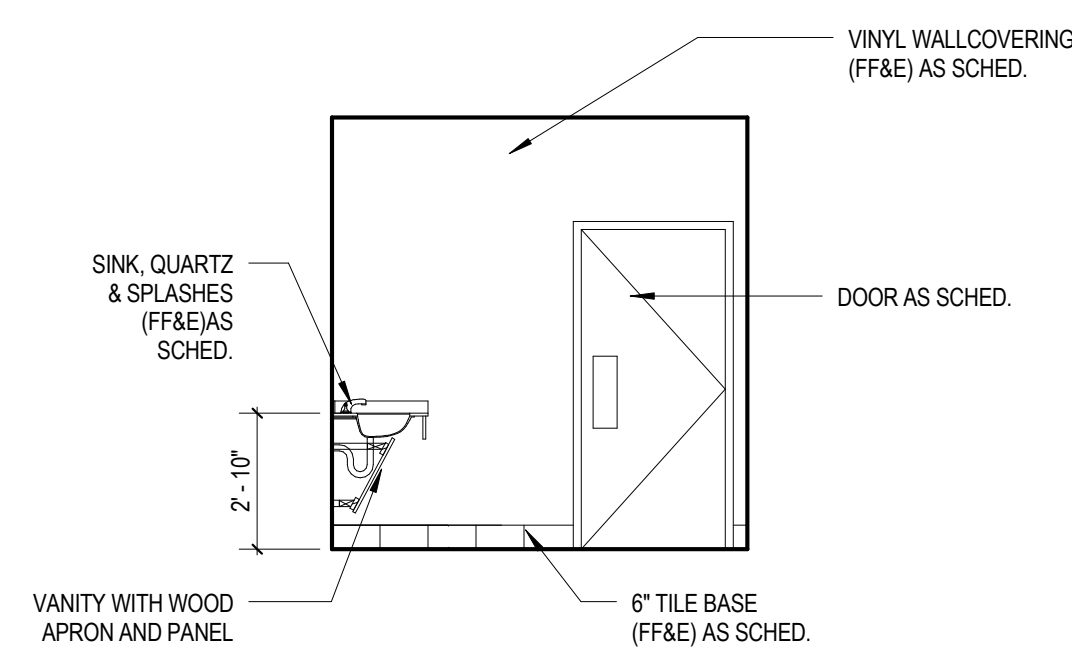

**05** INTERIOR ELEVATION @  
 MEN'S RESTROOM 228  
 1/4" = 1'-0"

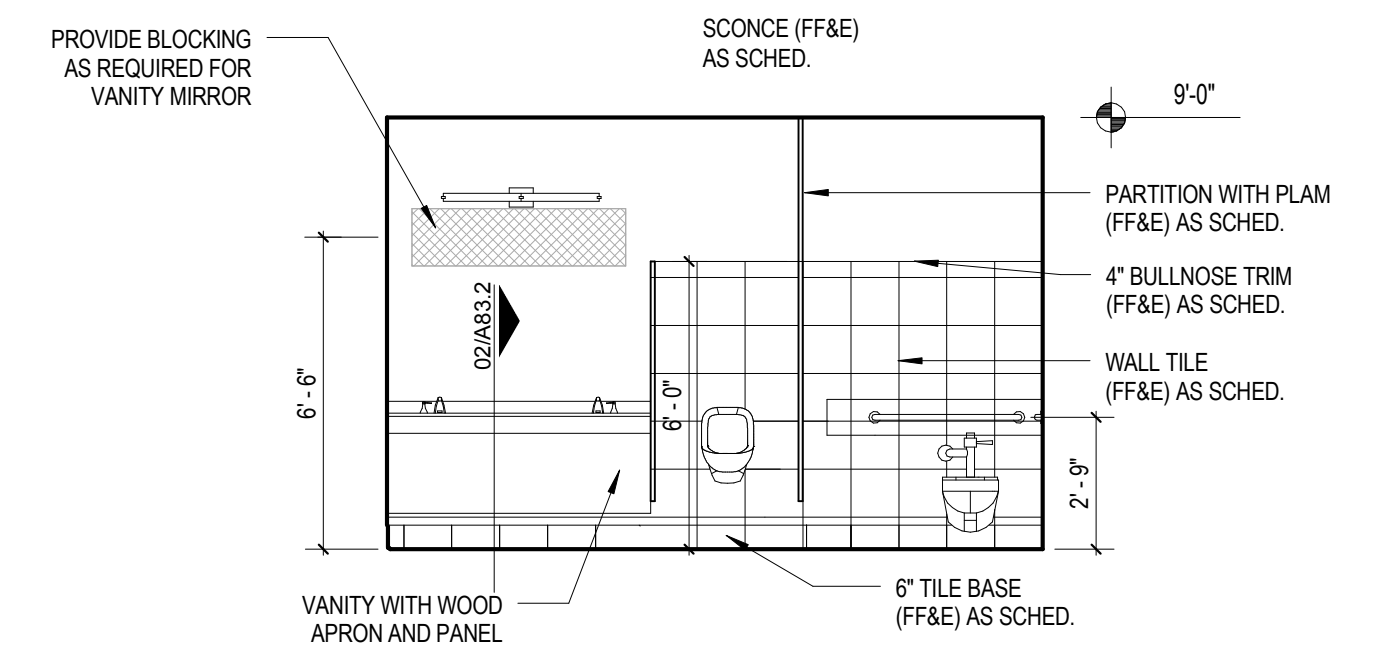

**06** INTERIOR ELEVATION @  
 MEN'S RESTROOM 228  
 1/4" = 1'-0"

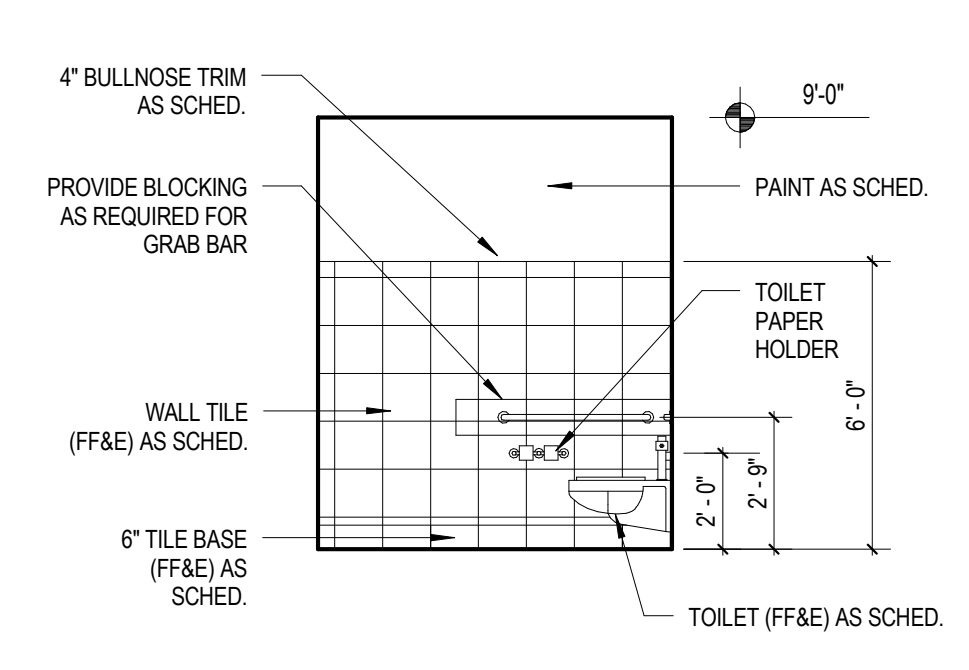

**07** INTERIOR ELEVATION @  
 MEN'S RESTROOM 228  
 1/4" = 1'-0"

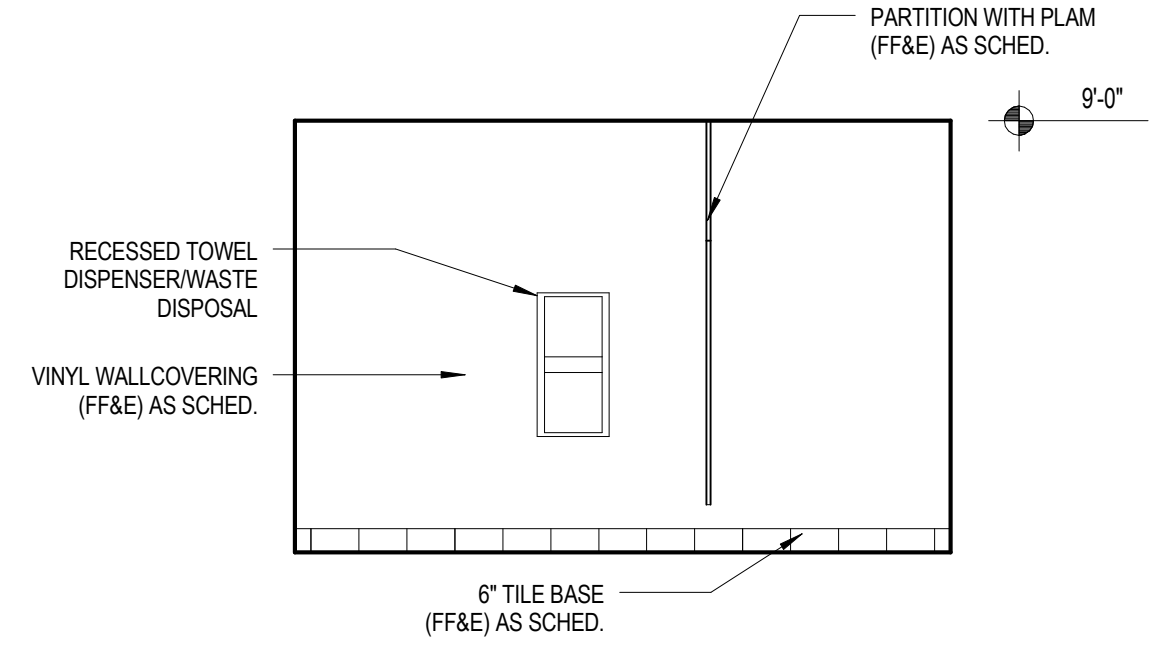

**08** INTERIOR ELEVATION @  
 MEN'S RESTROOM 228  
 1/4" = 1'-0"

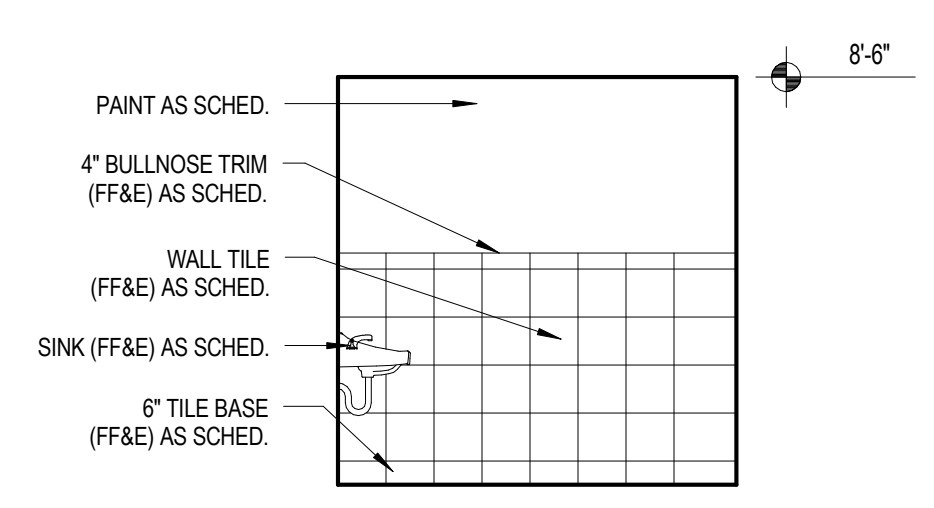

**09** INTERIOR ELEVATION @  
 POOL TOILET  
 1/4" = 1'-0"

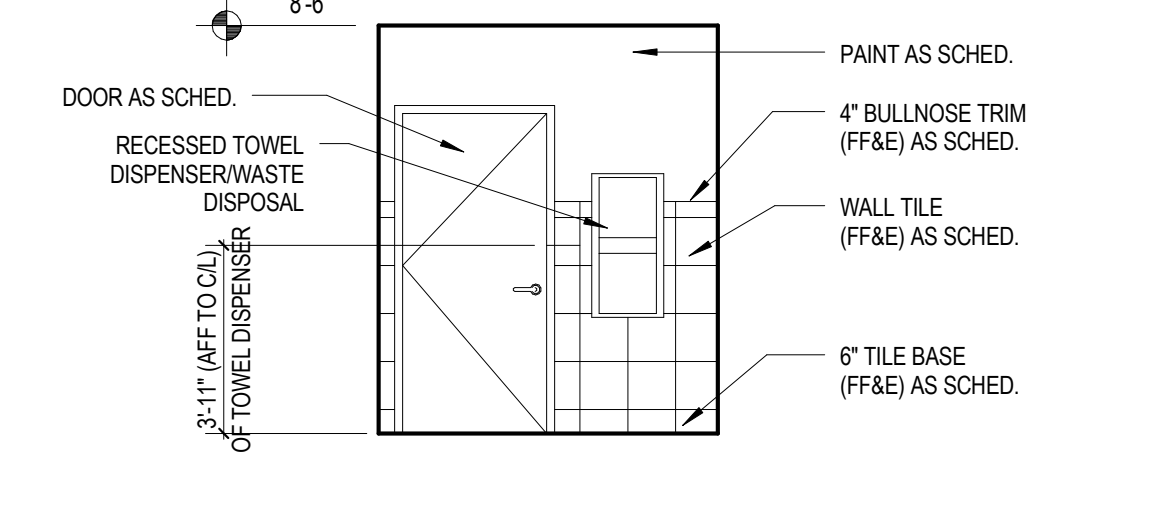

**10** INTERIOR ELEVATION @  
 EMPLOYEE RESTROOM  
 1/4" = 1'-0"

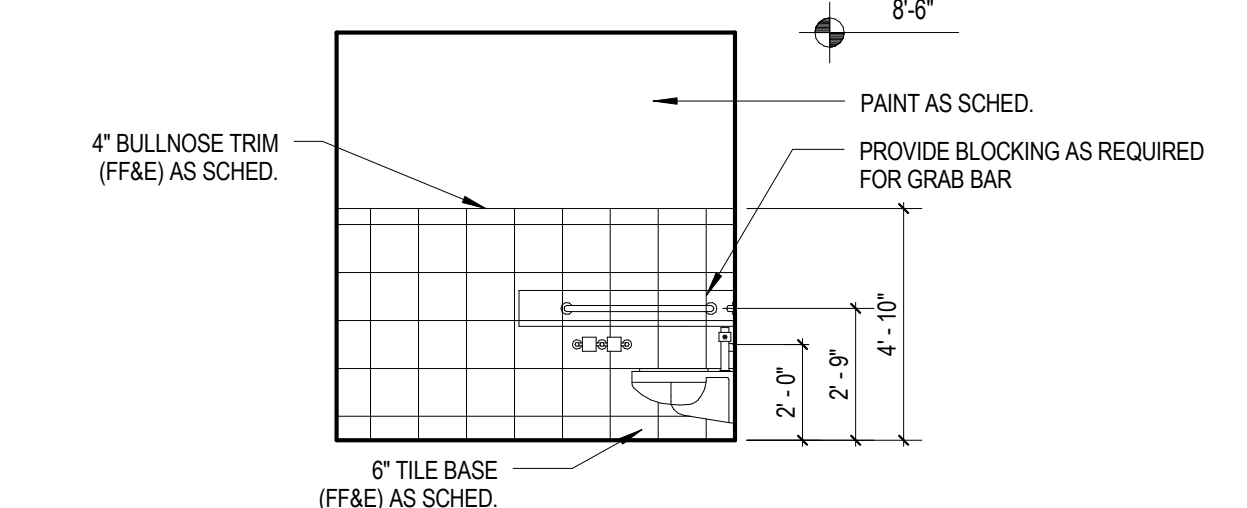

**11** INTERIOR ELEVATION @  
 EMPLOYEE RESTROOM  
 1/4" = 1'-0"

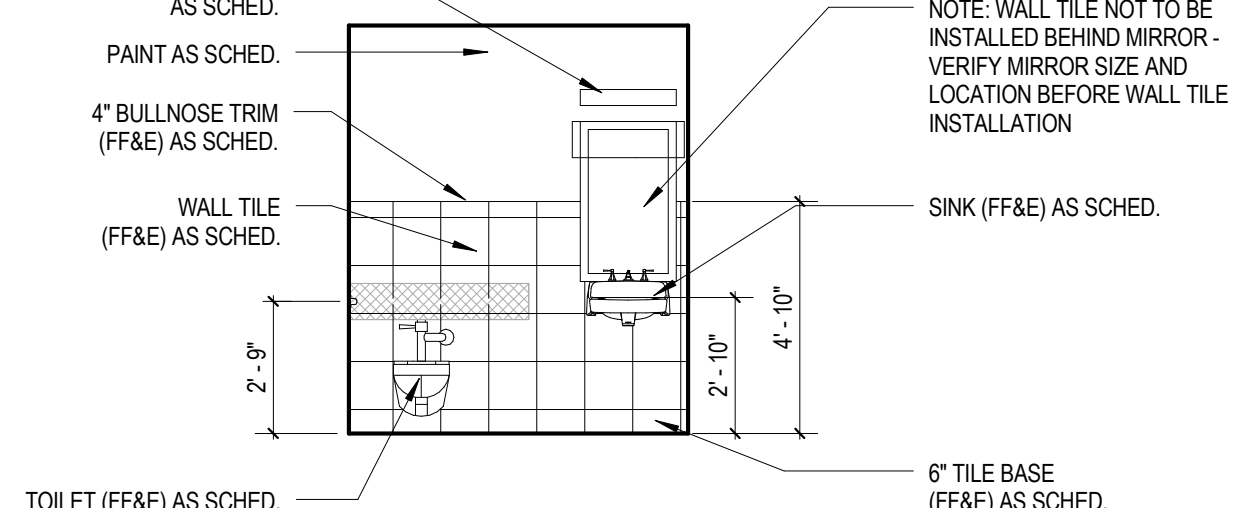

**12** INTERIOR ELEVATION @  
 EMPLOYEE RESTROOM  
 1/4" = 1'-0"

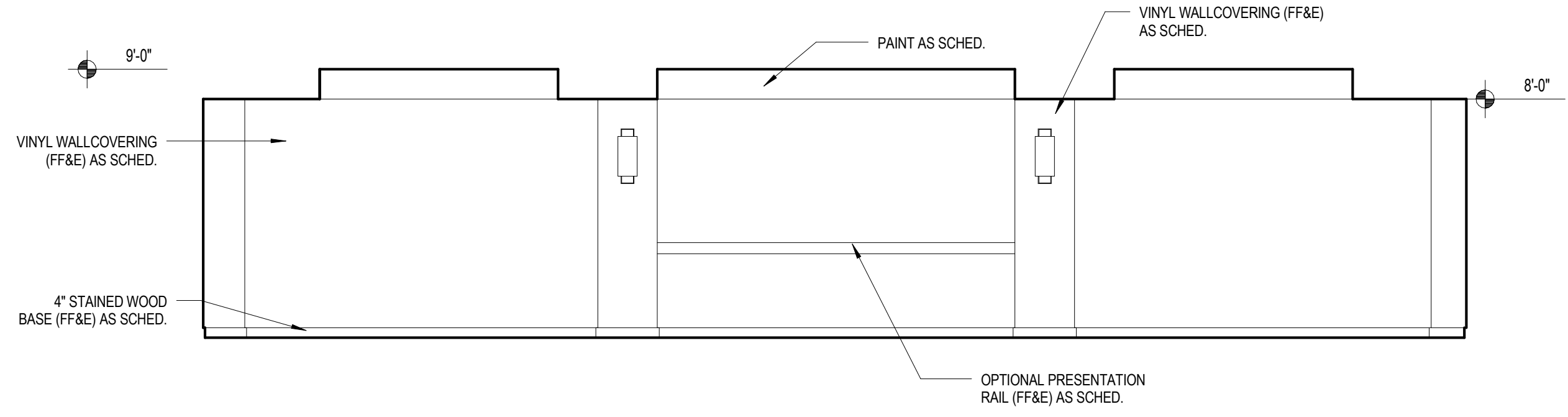

**13** INTERIOR ELEVATION @  
 MEETING ROOMS  
 1/4" = 1'-0"

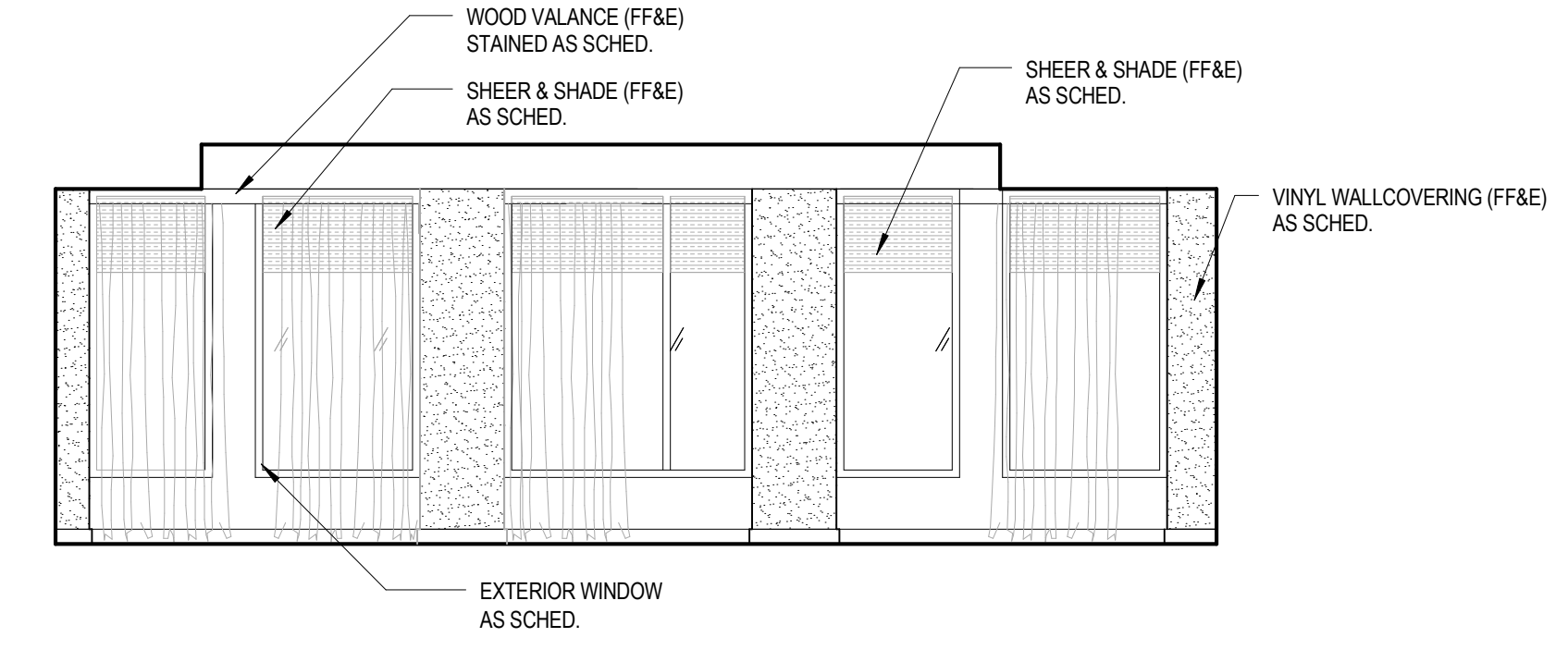

**14** INTERIOR ELEVATION @  
 MEETING ROOMS  
 1/4" = 1'-0"

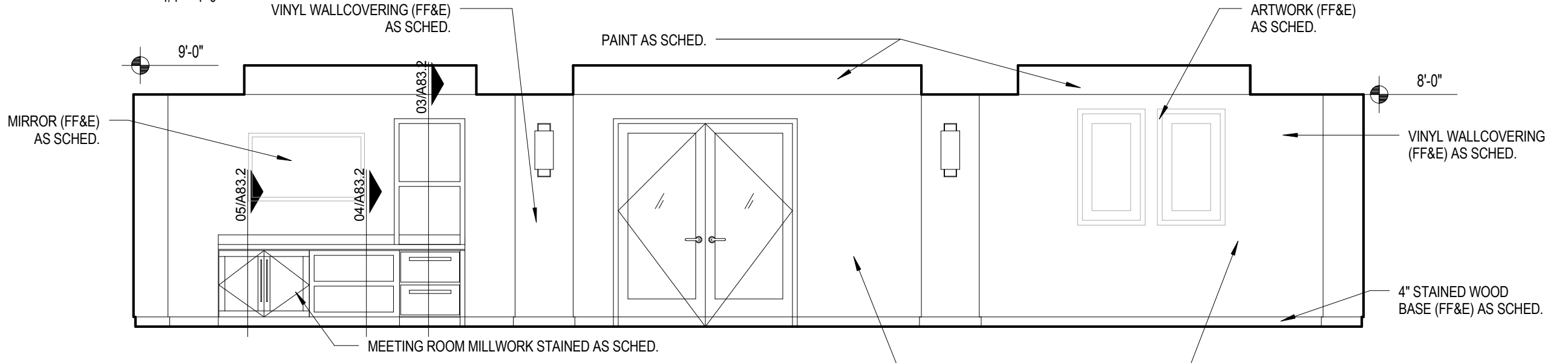

**15** INTERIOR ELEVATION @  
 MEETING ROOMS  
 1/4" = 1'-0"

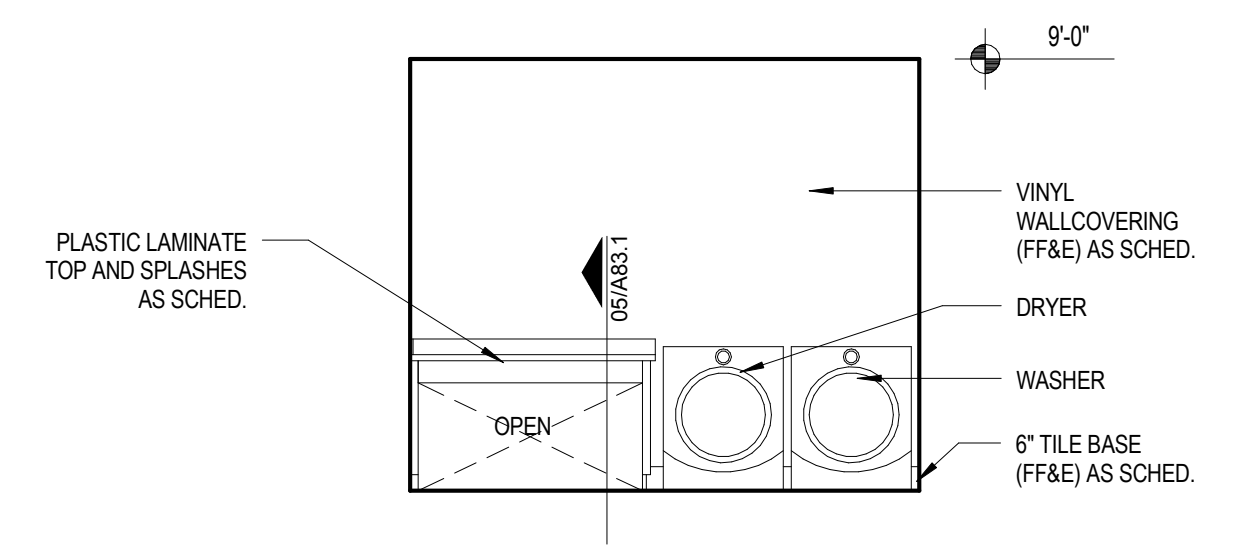

**16** INT. ELEV. @ GUEST LAUNDRY - FLOOR 2  
 1/4" = 1'-0"