

12 DETAIL LEVEL 3 PARAPET  
1 1/2" = 1'-0"

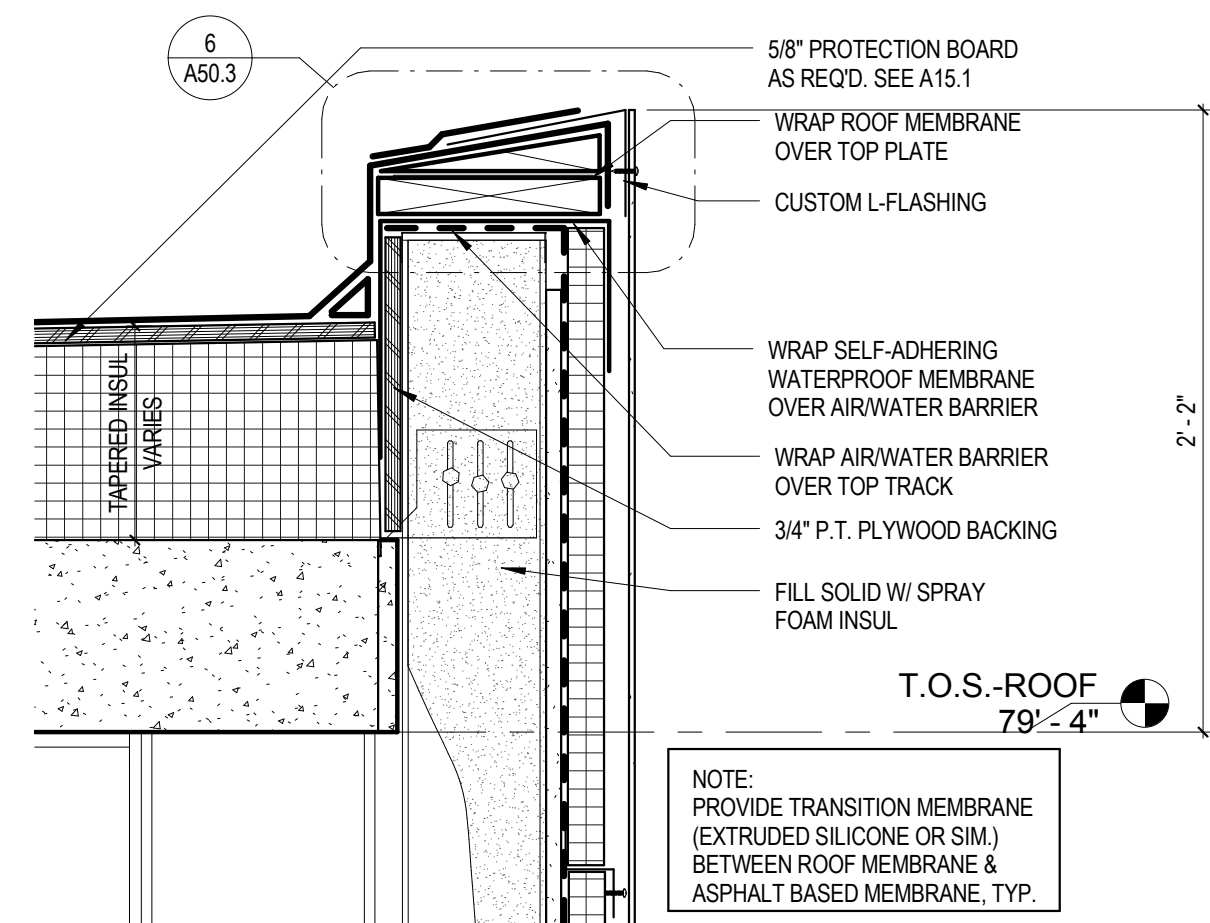

9 DETAIL PENTHOUSE PARAPET  
1 1/2" = 1'-0"

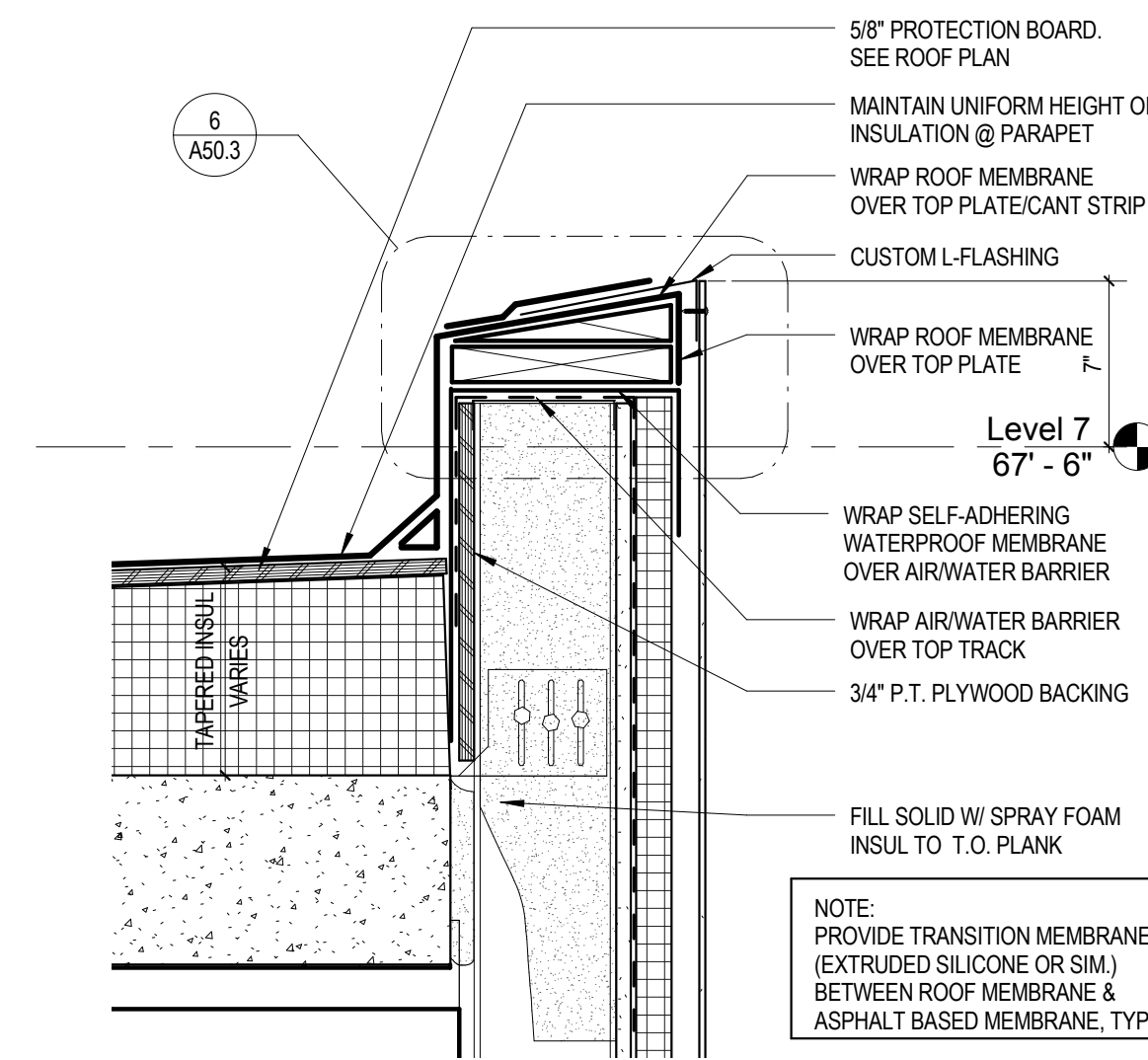

6 DETAIL LEVEL 7 PARAPET  
1 1/2" = 1'-0"

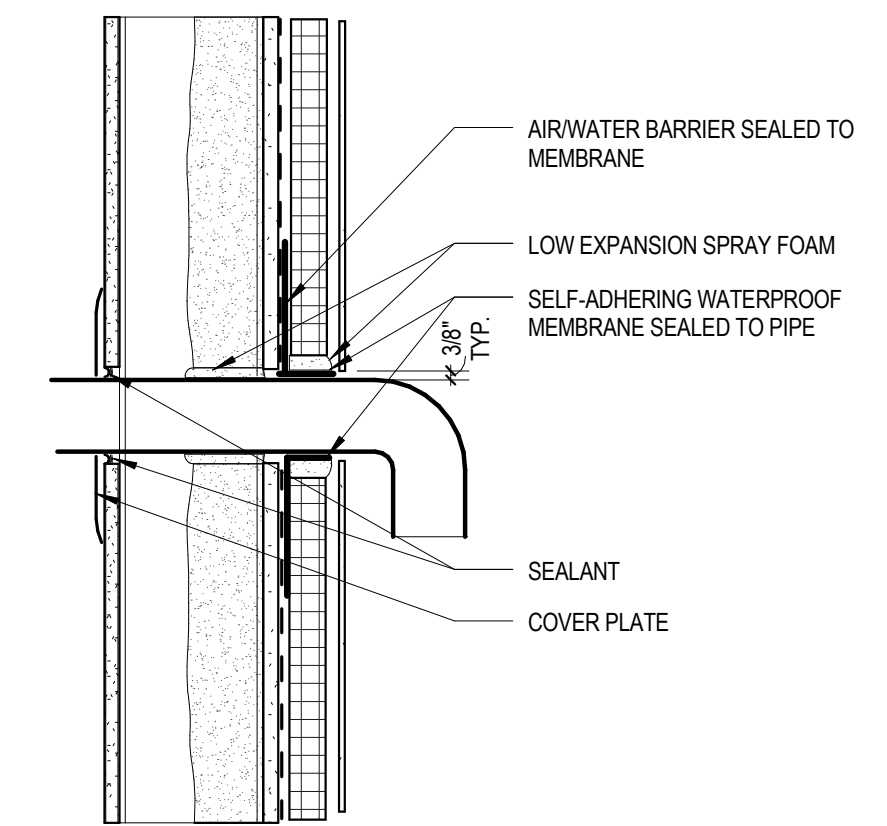

3 DETAIL PANEL SIDING PENETRATION, TYP.  
1 1/2" = 1'-0"

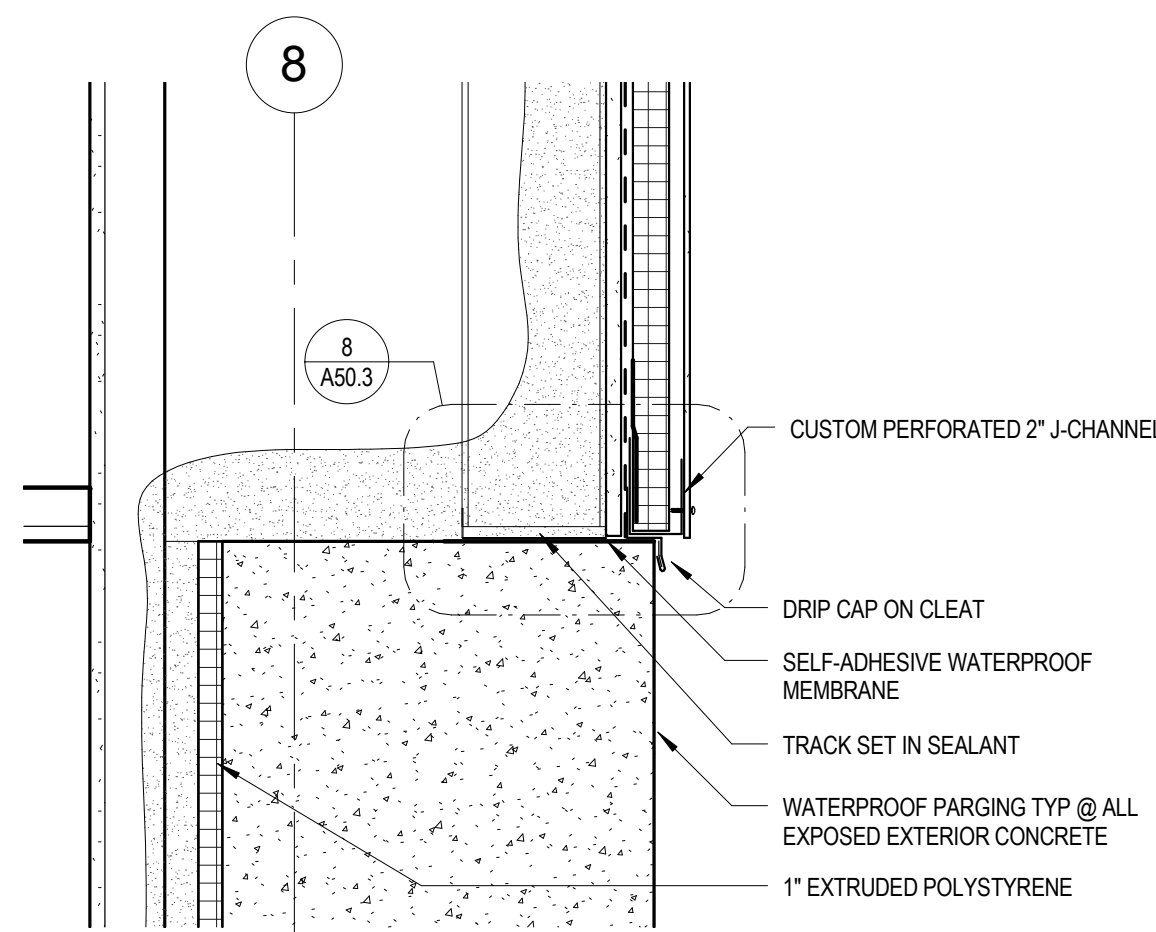

11 DETAIL BASE OF EAST WALL NORTH  
1 1/2" = 1'-0"

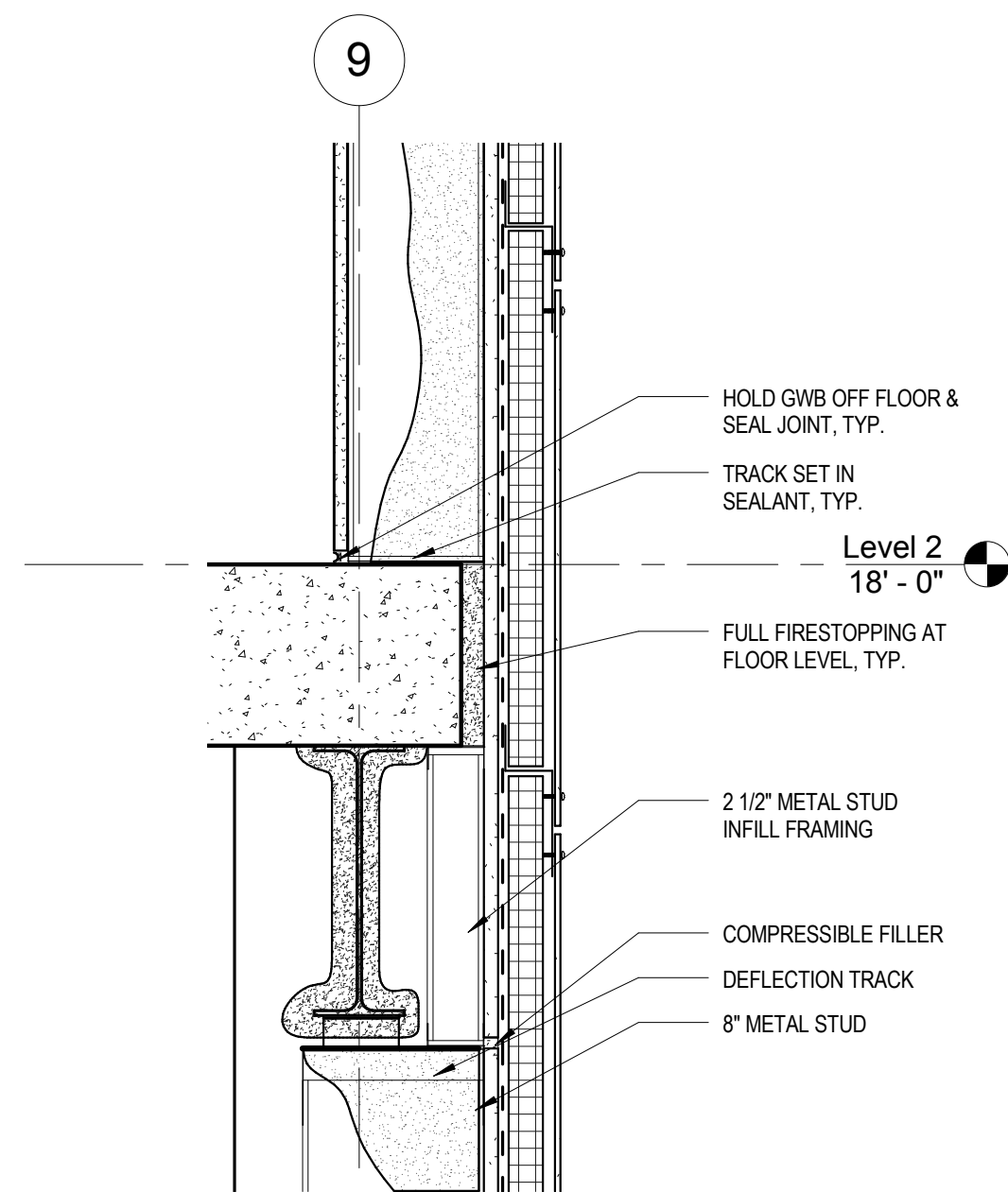

8 DETAIL EAST WALL LEVEL 2  
1 1/2" = 1'-0"

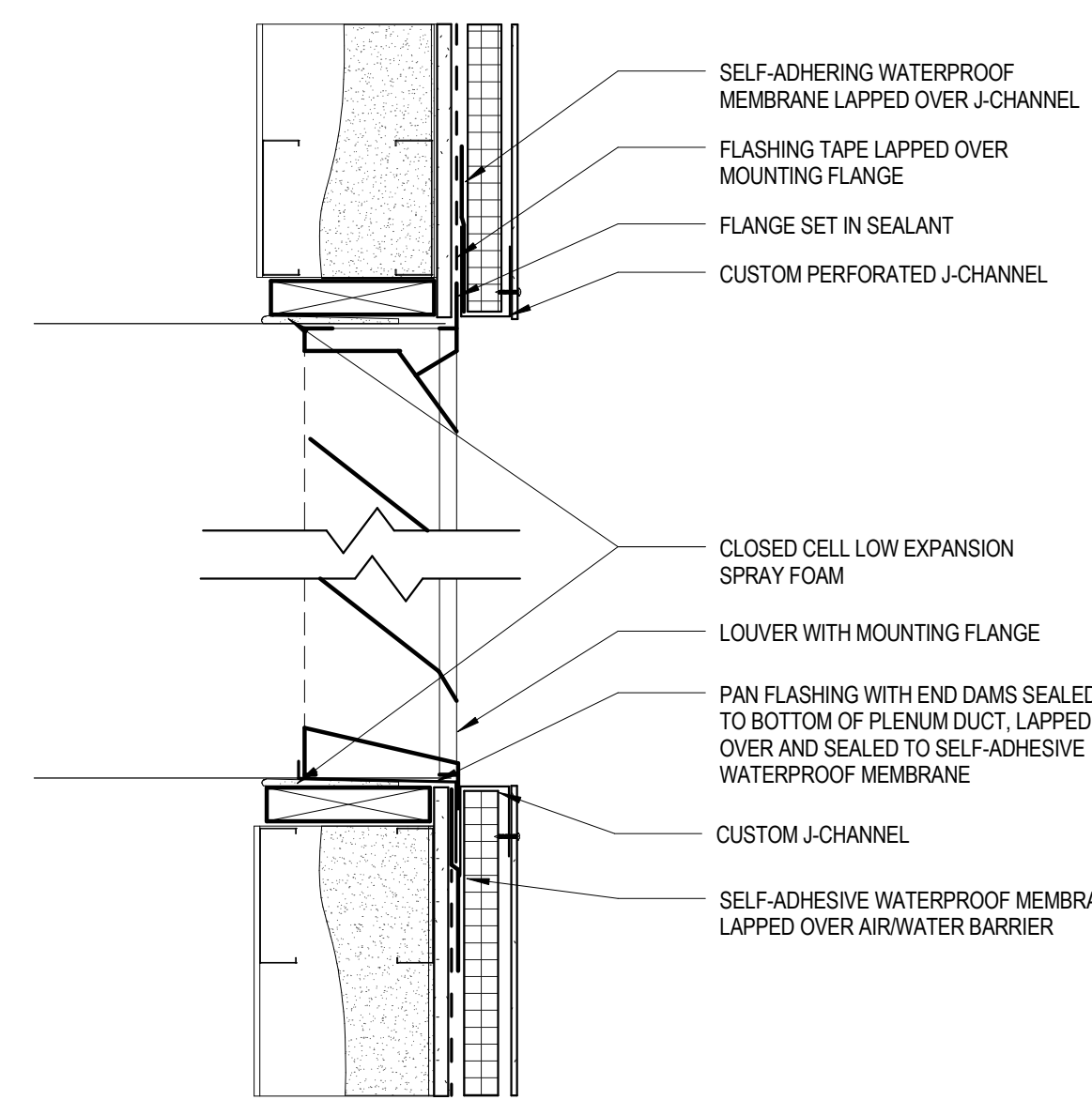

5 DETAIL WALL SECTION LOUVER, TYP.  
1 1/2" = 1'-0"

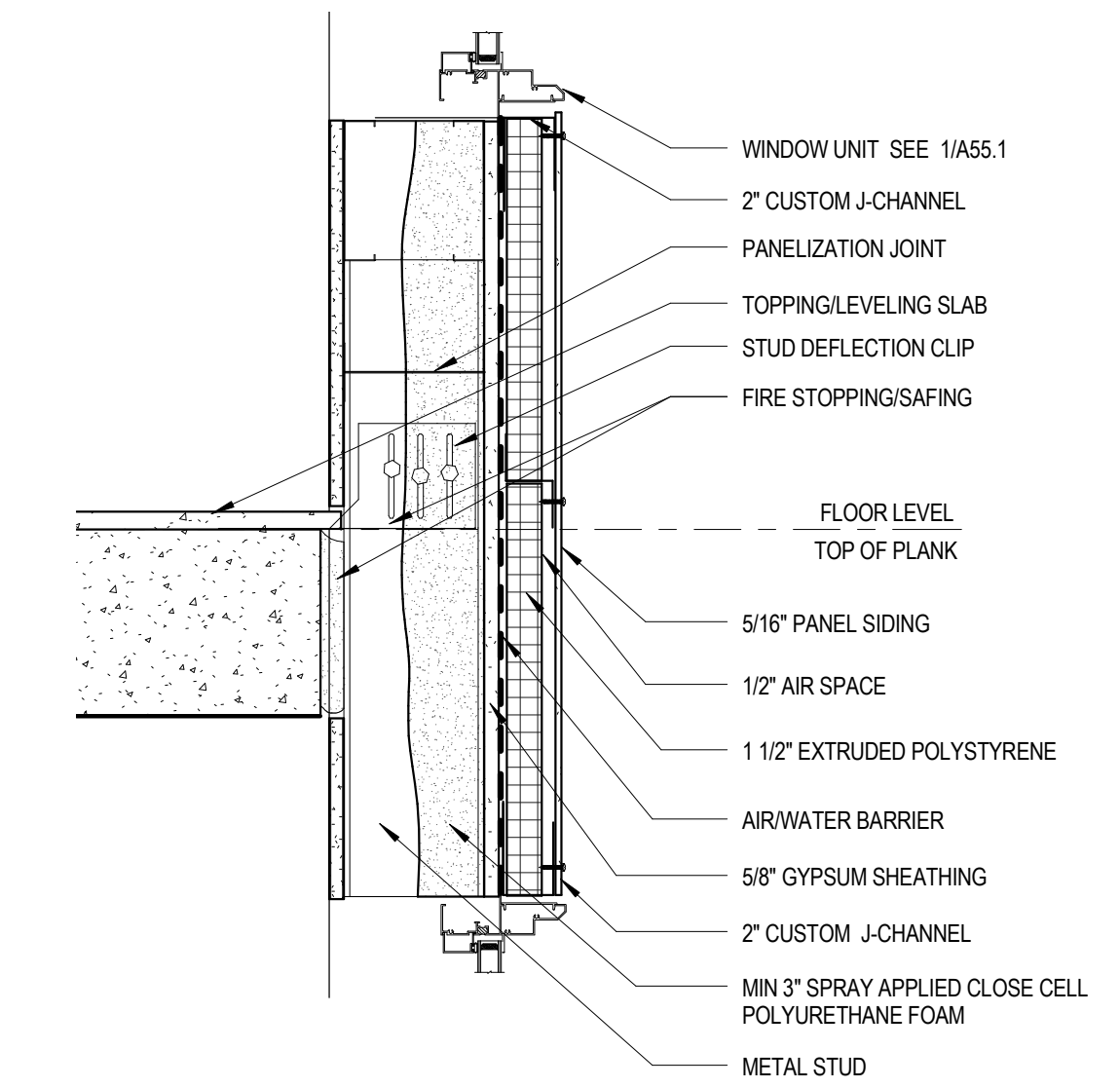

2 DETAIL PANEL SIDING WINDOW TYP  
1 1/2" = 1'-0"

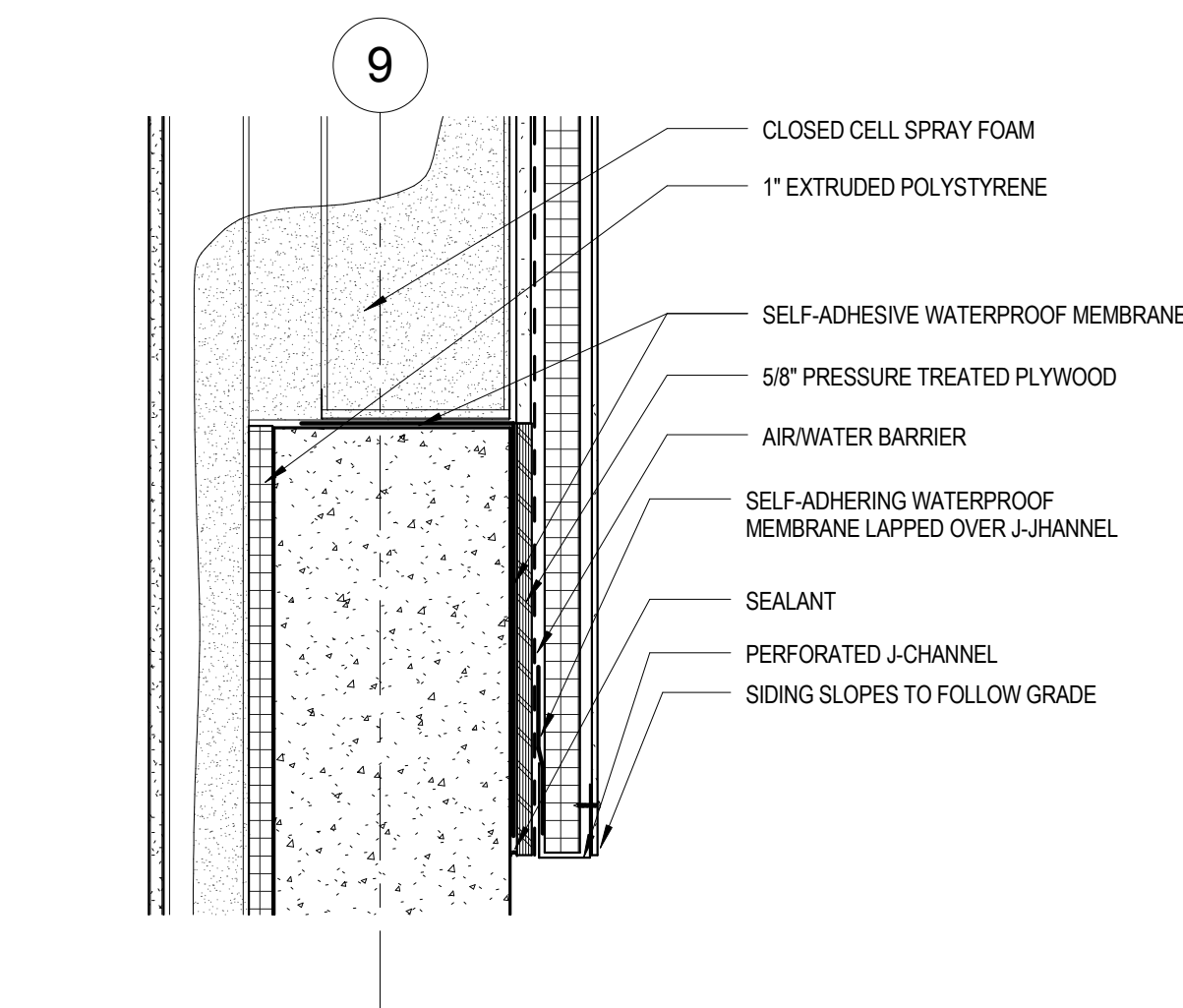

10 DETAIL BASE OF EAST WALL  
1 1/2" = 1'-0"

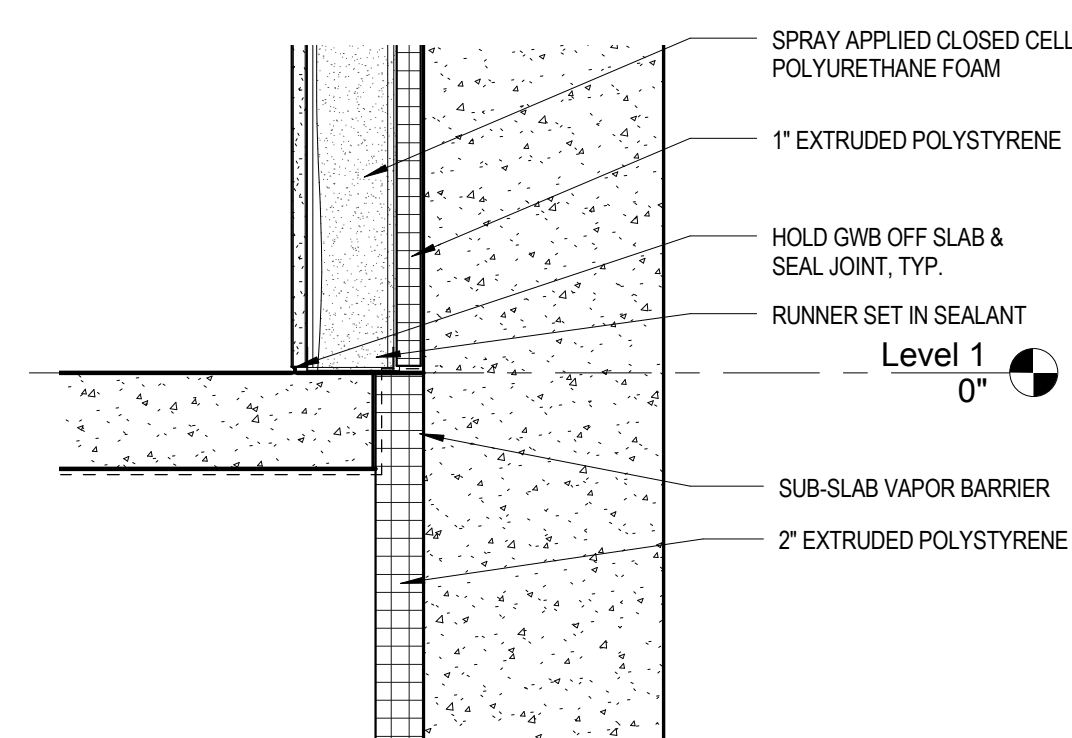

7 DETAIL FOUNDATION w/ INTERIOR PARTITION  
1 1/2" = 1'-0"

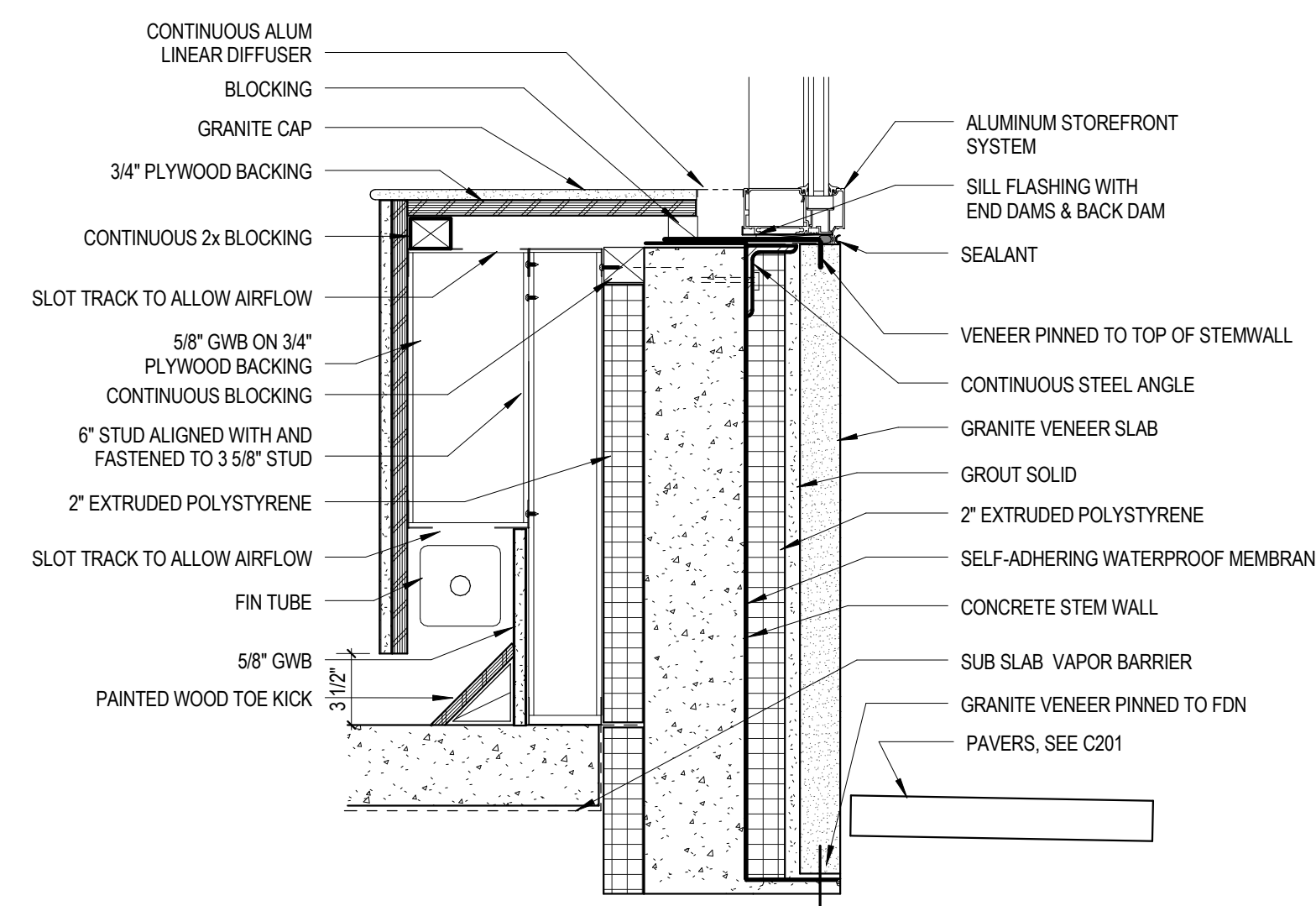

4 DETAIL BASE OF WALL STOREFRONT  
1 1/2" = 1'-0"

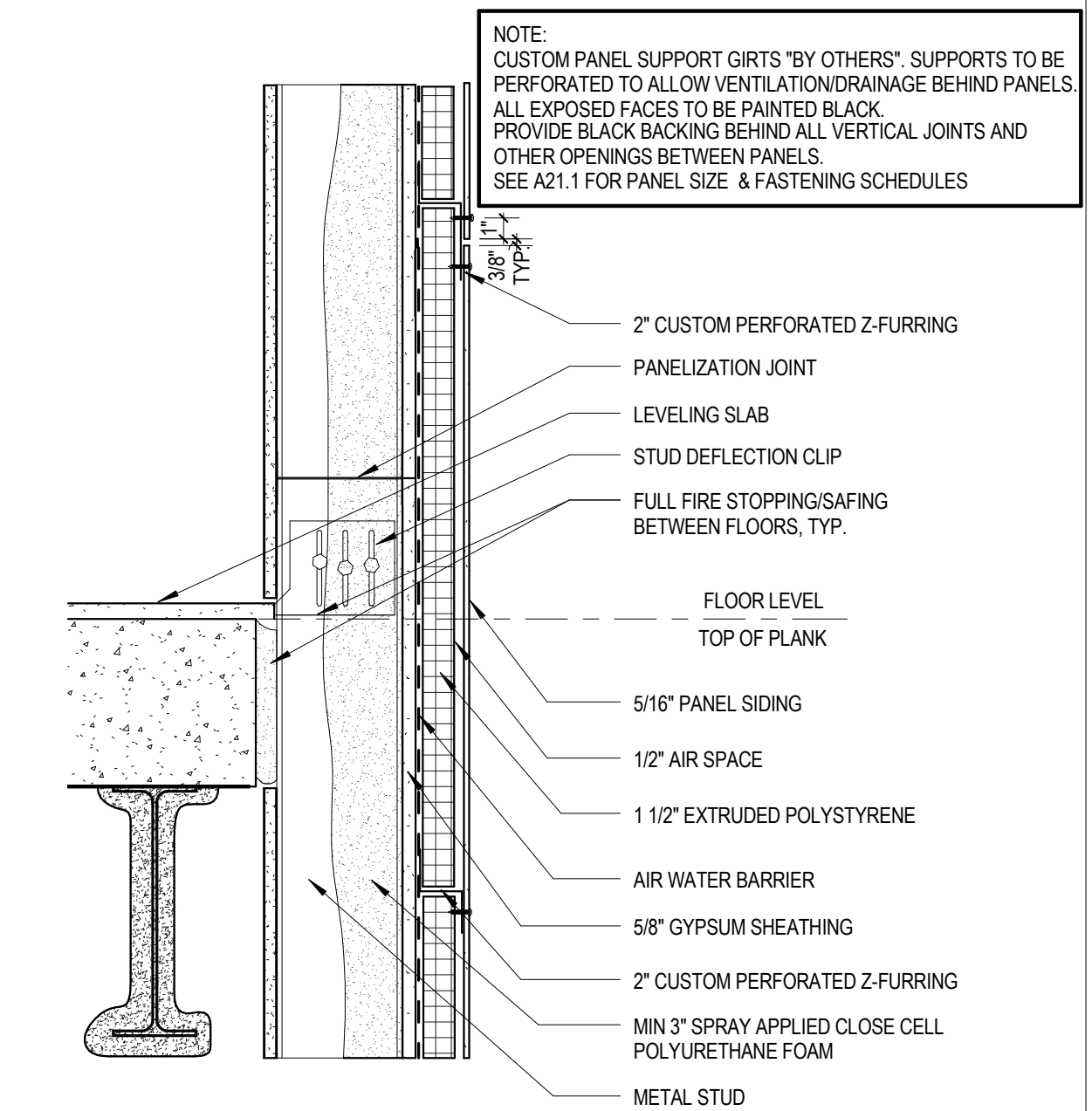

1 DETAIL PANEL SIDING WALL SECTION TYP  
1 1/2" = 1'-0"