

City of Portland, Maine - Building or Use Permit Application

389 Congress Street, 04101 Tel: (207) 874-8703, Fax: (207) 874-8716

Permit No: 04-0013	Issue Date: MAR 25 2004	CBL: 032 1012001
-----------------------	----------------------------	---------------------

Location of Construction: 10 Exchange St	Owner Name: 10 Exchange Properties Llc	Owner Address: Po Box 4894	Phone: 207-781-4072
---	---	-------------------------------	------------------------

Business Name: n/a	Contractor Name: The Signery	Contractor Address: 299 Forest Avenue Portland	Phone: 2078797700
-----------------------	---------------------------------	---	----------------------

Lessee/Buyer's Name: n/a	Phone: n/a	Permit Type: Signs - Permanent	Zone: B3/11.5
-----------------------------	---------------	-----------------------------------	------------------

Past Use: Commercial / Retail Store; Something Fishy	Proposed Use: Retail Store / JL Coombs; Erect 16 sq.ft of signs and one awning.	Permit Fee: \$97.00	Cost of Work: \$0.00	CEO District: 1
--	--	------------------------	-------------------------	--------------------

Proposed Project Description: Erect 16 sq. Ft of signs and one awning	FIRE DEPT: <input type="checkbox"/> Approved <input type="checkbox"/> Denied	INSPECTION: Use Group: B Type: sign/awning BAA 1999
--	--	--

Signature:	Signature: JMB 3/24/04
------------	------------------------

PEDESTRIAN ACTIVITIES DISTRICT (P.A.D.)

Action: Approved Approved w/Conditions Denied

Signature: _____ Date: _____

Permit Taken By: gg	Date Applied For: 01/02/2004	Zoning Approval	
------------------------	---------------------------------	------------------------	--

<ol style="list-style-type: none"> This permit application does not preclude the Applicant(s) from meeting applicable State and Federal Rules. Building permits do not include plumbing, septic or electrical work. Building permits are void if work is not started within six (6) months of the date of issuance. False information may invalidate a building permit and stop all work.. 	Special Zone or Reviews <input type="checkbox"/> Shoreland <input type="checkbox"/> Wetland <input type="checkbox"/> Flood Zone <input type="checkbox"/> Subdivision <input type="checkbox"/> Site Plan Maj <input type="checkbox"/> Minor <input type="checkbox"/> MM <input type="checkbox"/> Date: 1/2/04	Zoning Appeal <input type="checkbox"/> Variance <input type="checkbox"/> Miscellaneous <input type="checkbox"/> Conditional Use <input type="checkbox"/> Interpretation <input type="checkbox"/> Approved <input type="checkbox"/> Denied Date:	Historic Preservation <input type="checkbox"/> Not in District or Landmark <input type="checkbox"/> Does Not Require Review <input checked="" type="checkbox"/> Requires Review <input checked="" type="checkbox"/> Approved <input type="checkbox"/> Approved w/Conditions <input type="checkbox"/> Denied TO D.A Date: 1/8/04
	D. Andrew B 3/19/04		

CERTIFICATION

I hereby certify that I am the owner of record of the named property, or that the proposed work is authorized by the owner of record and that I have been authorized by the owner to make this application as his authorized agent and I agree to conform to all applicable laws of this jurisdiction. In addition, if a permit for work described in the application is issued, I certify that the code official's authorized representative shall have the authority to enter all areas covered by such permit at any reasonable hour to enforce the provision of the code(s) applicable to such permit.

SIGNATURE OF APPLICANT ADDRESS DATE PHONE

RESPONSIBLE PERSON IN CHARGE OF WORK, TITLE DATE PHONE

City of Portland, Maine - Building or Use Permit

389 Congress Street, 04101 Tel: (207) 874-8703, Fax: (207) 874-8716

Permit No: 04-0013	Date Applied For: 01/02/2004	CBL: 032 I012001
------------------------------	--	----------------------------

Location of Construction: 10 Exchange St	Owner Name: 10 Exchange Properties Llc	Owner Address: Po Box 4894	Phone: 207-781-4072
Business Name: n/a	Contractor Name: The Signery	Contractor Address: 299 Forest Avenue Portland	Phone: (207) 879-7700
Lessee/Buyer's Name: n/a	Phone: n/a	Permit Type: Signs - Permanent	

Proposed Use: Retail Store / JL Coombs; Erect 16 sq.ft of signs and one awning.	Proposed Project Description: Erect 16 sq. Ft of signs and one awning
---	---

Dept: Historical	Status: Approved	Reviewer: Deborah Andrews	Approval Date: 03/19/2004
Note:			Ok to Issue: <input checked="" type="checkbox"/>
Dept: Zoning	Status: Approved	Reviewer: Marge Schmuckal	Approval Date: 01/08/2004
Note:			Ok to Issue: <input checked="" type="checkbox"/>
Dept: Building	Status: Approved	Reviewer: Jeanine Bourke	Approval Date: 03/24/2004
Note: 3/22/04 left vm for Ron @ ME Bay Canvas for snow load & spoke w/Bob P. To clarify the signs & brackets Ok to Issue: <input checked="" type="checkbox"/>			
3/24 received specs from ME Bay, ok to issue			

DISPLAY THIS CARD ON PRINCIPAL FRONTAGE OF WORK CITY OF PORTLAND

BUILDING DEPARTMENT

PERMIT

Permit Number: 040013

Please Read Application And Notes, If Any, Attached

This is to certify that 10 Exchange Properties Llc / Signer _____
has permission to Erect 16 sq. Ft of signs and o wning _____
AT 10 Exchange St _____ City 032 I012001 _____

provided that the person or persons, firm or corporation accepting this permit shall comply with all of the provisions of the Statutes of Maine and of the Ordinances of the City of Portland regulating the construction, maintenance and use of buildings and structures, and of the application on file in this department.

Notification of inspection must be given and written permission procured before this building or part thereof is altered or closed-in. 24 HOUR NOTICE IS REQUIRED.

Apply to Public Works for street line and grade if nature of work requires such information.

A certificate of occupancy must be procured by owner before this building or part thereof is occupied.

OTHER REQUIRED APPROVALS

Fire Dept. _____
Health Dept. _____
Appeal Board _____
Other _____
Department Name

James Bourke 3/24/04
Director - Building & Inspection Services

PENALTY FOR REMOVING THIS CARD

Signage/Awning Permit Application

If you or the property owner owes real estate or personal property taxes or user charges on any property within the City, payment arrangements must be made before permits of any kind are accepted.

Location/Address of Construction: <u>22 Exchange St. Portland</u>		
Total Square Footage of Proposed Structure	Square Footage of Lot	
Tax Assessor's Chart, Block & Lot Chart# <u>32</u> Block# <u>I</u> Lot# <u>17</u> <small>124 134</small>	Owner: <u>10 EXCHANGE LLC</u>	Telephone: <u>207 781-4072</u>
Lessee/Buyer's Name (If Applicable)	Applicant name, address & telephone: <u>J.L. COOMBS</u> <u>262-2 U.S. ROUTE 1</u> <u>FREEPORT, MAINE 04032</u> <u>207-865-4333</u>	Total s.f. of signage x \$1.00 ^{\$1.25} per s.f. plus \$30.00 = Total Fee: \$ Awning Fee = Cost Of Work: \$ Total Fee: \$
Current use: <u>RETAIL STORE - Something's Fishy</u>		<u>3200</u> ¹¹⁶ <u>6500</u> (incl. # Driveway) \$ <u>97.00</u>
If the location is currently vacant, what was prior use: _____		
Approximately how long has it been vacant: _____		
Proposed use: <u>RETAIL STORE - JL Coombs add.</u>		
Project description: <u>SHOE STORE</u>		
Contractor's name, address & telephone: _____ <u>207-865-4333</u>		
Who should we contact when the permit is ready: <u>ROBERT PEARL</u> #205		
Mailing address: <u>262-2 U.S. Rt. 1 Freeport, ME. 04032</u>		
We will contact you by phone when the permit is ready. You must come in and pick up the permit and review the requirements before starting any work, with a Plan Reviewer. A stop work order will be issued and a \$100.00 fee if any work starts before the permit is picked up. PHONE: <u>865-4333</u>		

IF THE REQUIRED INFORMATION IS NOT INCLUDED IN THE SUBMISSIONS THE PERMIT WILL BE AUTOMATICALLY DENIED AT THE DISCRETION OF THE BUILDING/PLANNING DEPARTMENT. WE MAY REQUIRE ADDITIONAL INFORMATION IN ORDER TO APPROVE THIS PERMIT.

I hereby certify that I am the Owner of record of the named property, or that the owner of record has authorized me to prepare the proposed work and that I have been authorized by the owner to make this application as his/her authorized agent. I agree to conform to all applicable laws of this jurisdiction. In addition, if a permit for work described in this application is issued, I certify that the Code Official's authorized representative shall have the authority to enter all areas covered by this permit at any reasonable hour to enforce the provisions of the codes applicable to this permit.

Signature of applicant: 	Date: <u>JAN 2 2015</u>
---	-------------------------

This is NOT a permit, you may not commence ANY work until the permit is issued.

EXISTING STORE FRONT -



ESTIMATE - CONTRACT

SOLD TO: J.L. Coombs
 DEL. ADDRESS 22 Exchange ST.
Portland ME.04103
 MAIL ADDRESS _____

W.O. #	_____
JOB #	_____
DATE	<u>12/1/03</u>
EST. DEL. DATE	<u>3 weeks from order</u>
HOME PHONE	<u>865-4333</u>
BUS. PHONE	<u>fax 865-1711</u>
FRAME STYLE	<u>Dome</u>
FAERIC & COLOR	<u>Sunbrella / Choice</u>
FABRIC STYLE #	<u>Firesist</u>

Manufacture and install one dome style door canopy.

Scope of work: Remove existing awning and reinstall new door canopy.

The new awning will be an elongated style dome.
 The frame will be welded construction with all the welds being wire brushed primed and painted to match the frame work.

The fabric will be Sunbrella Firesist woven acrylic in your choice of color.

The new awning will be installed true and plumb, 3' off the sidewalk to the bottom of frame.

ITEM: as above	ESTIMATE
	\$ 840.00
tax	\$ 38.00
ESTIMATE TOTAL	\$ 878.00
LESS DEPOSIT	50%
DUE UPON INSTALLATION	net

CONTINUED AGREEMENT

Maine Bay Canvas, Inc. agrees to sell, deliver and install to the Buyer and the Buyer agrees to purchase and accept from Maine Bay Canvas, Inc. the above described goods or property, subject to and upon the terms and conditions hereof expressed. Any alteration or deviation from specifications involving extra work will become an additional charge over and above the quote.

Until the said total balance is paid in full and all of the conditions hereof are fully performed title to and ownership of the property purchased under this contract shall be and remain the property of Maine Bay Canvas, Inc.

No cancellations will be accepted after work has started, or on special order merchandise. Delivery dates shown are approximate unless otherwise stated.

Accounts 30 days past stated terms will be subject to a 1.5% annual finance charge.

BUYER _____

SELLER Arvid D. Kelly

Maine Bay Canvas

53 Industrial Way
 Portland, Maine 04103

207-878-8888

Fax: 878-5119

Fastening Detail

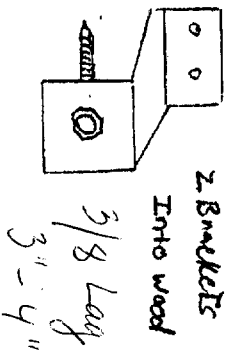

Total - 7 Lags

per Frank @ WE Bay

3/23/04

Katersfield

Allied Tubing

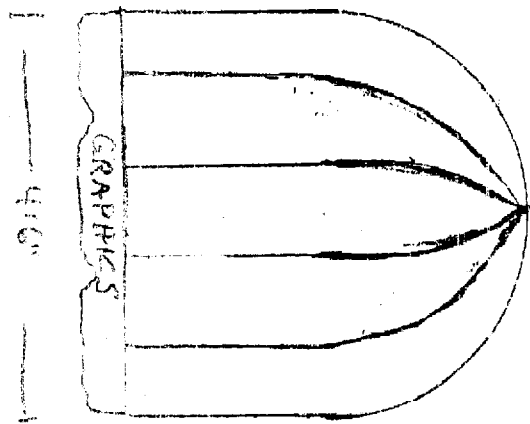
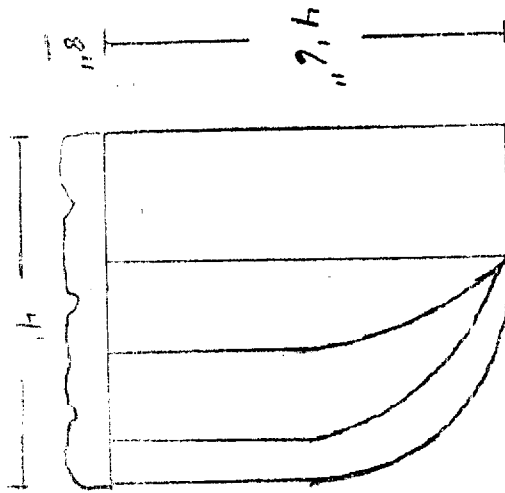

w/ side walk

FAX TRANSMITTAL # of Pages: 1
 TO: Bob Neph FROM: Ron
 MAINE BAY CANVAS INC.
 PHONE: (207) 878-8986 FAX # (207) 878-5119
 WEBSITE: mainebaycanvas.com
 COMMENTS



GENERIC CLASSIFICATION	Solution Dyed Modacrylic.
DESCRIPTION	Woven fabric made of 100% SEF/PLUS® Self-extinguishing fibers. These are modacrylic solution dyed fibers with a fluorocarbon finish.
WEIGHT	Approximately 9.25 oz. per square yard. 314 grams per square meter.
WIDTH	60 inches or 152.4 cm.
COLOR	Very resistant to ultraviolet rays & color degradation (see warranty). Most colors tested up to 1500 hours in fadeometer with minimal or no change. Fade resistant to most chemicals.
DURABILITY / AVERAGE LIFE SPAN	5-10 years. (Depends on climate & proper use of fabric.)
SURFACE	Plain weave. Excellent breathability.
UNDERSIDE	Same as top surface, both sides alike.
TRANSPARENCY LEVEL	Light shades translucent for good illuminated use.
ABRASION RESISTANCE	Good.
FLEXIBILITY	Excellent in both hot & very cold conditions. Will not crack or peel.
FABRIC IDENTIFICATION	Contrasting marker yarn in selvage gives positive identification.
FLAME RESISTANCE (FR)	Fabric does not melt drip & is inherently flame retardant passing the following flame retardant requirements: <ul style="list-style-type: none"> • California State Fire Marshall's Test Procedure #801. Title 19. Registration #F368.01. • NFPA 701. • ASTM E-84-00a - Values for flame spread and smoke density are Class A or Class 1 building material. • F.A.A. 25.853(a) interior aircraft textiles and furnishings. • FMVSS302: Auto, bus, train. • CPAI-84: Tent walls and roof. • New York Board of Standards 294-40-SR. • UFAC: Upholstered furniture. • NFPA 1975 - Fireman's station uniform (FTMS 5903-191) and institutional blankets. • UL 214 Certification (U.S.). • CAN/UL S109 Certification (Canada). • Outside North America - Consult Glen Raven for Specifications.
MILDEW RESISTANT	Excellent. Fabric will not support growth of mildew. Mildew growing on foreign matter attached to fabric is easily removed.
CHEMICAL RESISTANCE	Fabric highly resistant to acids, alkalis, & solvents.
WATER REPELLENCY	Excellent.
OIL RESISTANCE	Good.
SEWABILITY	Excellent.
HEAT SEALING	Can be heat sealed using sealing tape & heat source such as radio frequency bar type welder.

GENERIC CLASSIFICATION	Solution Dyed Modacrylic with an acrylic/urethane coating.
DESCRIPTION	Woven fabric made of 100% SEF/PLUS® Self-extinguishing fibers. These are modacrylic solution dyed fibers with a fluorocarbon finish.
WEIGHT	Approximately 10.25 oz. per square yard, 348 grams per square meter.
WIDTH	60 inches or 152.4 cm.
COLOR	Very resistant to ultraviolet rays & color degradation (see warranty). Most colors tested up to 1500 hours in fadeometer with minimal or no change. Fade resistant to most chemicals.
DURABILITY / AVERAGE LIFE SPAN	5-10 years. (Depends on climate & proper use of fabric.)
SURFACE	Plain weave.
UNDERSIDE	Coated with acrylic/urethane.
TRANSPARENCY LEVEL	Light shades translucent for good illuminated use.
ABRASION RESISTANCE	Good.
FLEXIBILITY	Excellent in both hot & very cold conditions. Will not crack or peel.
FABRIC IDENTIFICATION	Contrasting marker yarn in selvage gives positive identification.
FLAME RESISTANCE (FR)	Fabric does not melt drip & is inherently flame retardant passing the following flame retardant requirements: <ul style="list-style-type: none"> • California State Fire Marshall's Test Procedure #801. Title 19, Section 1237. Registration # available upon request. • NFPA 701--99 Test Method 2. • ASTM E-84-00a - Values for flame spread and smoke density are Class A or Class 1 building material. • F.A.A. 25.853(a) interior aircraft textiles and furnishings. • FMVSS302: Auto, bus, train. • CPAI-84: Tent walls and roof. • New York Board of Standards 294-40-SR. • UFAC: Upholstered furniture. • UL 214 Certification (U.S.). • CAN/UL S109 Certification (Canada). • Outside North America - Consult Glen Raven for Specifications.
MILDEW RESISTANT	Excellent. Fabric will not support growth of mildew. Mildew growing on foreign matter attached to fabric is easily removed.
CHEMICAL RESISTANCE	Fabric highly resistant to acids, alkalis, & solvents.
WATER REPELLENCY	Superior.
OIL RESISTANCE	Good.
SEWABILITY	Excellent.
HEAT SEALING	Can be heat sealed using sealing tape & heat source such as radio frequency bar type welder.

SUNBRELLA FIRESIST® & SUNBRELLA FIRESIST® "PLUS" five year limited warranty

This warranty is valid only if its accompanying certificate is completed and mailed within 10 days of installation. This warranty covers the fabric becoming unserviceable because of loss of color or strength from normal exposure conditions including sunlight, mildew, rot and atmospheric chemicals. It does not cover labor and installation supplied by the dealer. The warranty coverage runs for 5 years from the date of the original installation. Glen Raven will supply new fabric free to replace the fabric which becomes unserviceable. Call the dealer from whom you purchased this product to inspect the installation. The dealer will contact Glen Raven and secure replacement fabric for you. This warranty gives you specific legal rights and you may also have other rights which vary from state to state.



Size
36x

Don't
miss

J.L. COOMBS



— New sign —

ONE ART

EXISTING Lights

36 X 25

4'6" X 4'

IT GEOMAS

"The Squire"
Forest Ave.
Portland

40"
THE SQUARE
FOREST AVE
PORTLAND

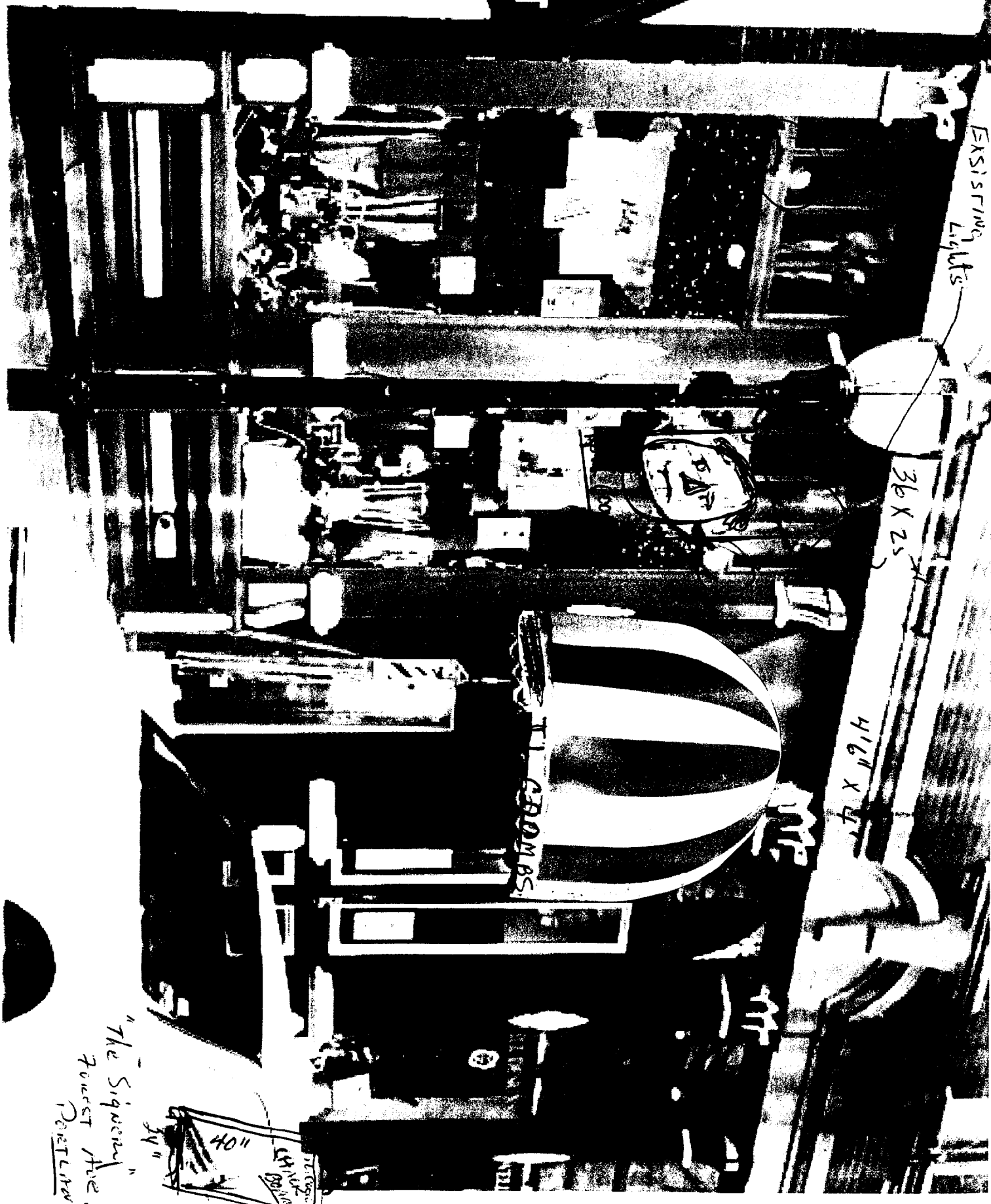

SIGNAGE/AWNING PRE-APPLICATION QUESTIONNAIRE

PLEASE ANSWER ALL QUESTIONS

ADDRESS: 22 EXCHANGE ST. PORTLAND ZONE: B3

CBL: _____

SINGLE TENANT LOT? YES _____ NO X MULTI TENANT LOT? YES X NO _____

MORE THAN ONE SIGN TOTAL WITH PROPOSED SIGN? YES X NO _____

INFORMATION ON PROPOSED SIGN(S):

FREESTANDING (e.g., pole) SIGN? YES 1 NO _____ DIMENSIONS PROPOSED: 24" x 40" *7 ft sandwich sign*

BLDG. WALL SIGN? (attached to bldg) YES 1 NO _____ DIMENSIONS PROPOSED: 36" x 25" *6.25'*

INFORMATION ON ALREADY EXISTING AND PERMITTED SIGN(S):

FREESTANDING (e.g., pole) SIGN? YES 1 NO _____ DIMENSIONS: 24" x 40" = 960 *6.67'*

BLDG. WALL SIGN(attached to bldg) ? YES 1 NO _____ DIMENSIONS: 41" x 22" *6.26'*

AWNING? YES 1 NO _____ DIMENSIONS: 20' x 5" x 3" = 300" + 41" x 22" = 902 *8.35'*

LOT FRONTAGE (FEET): 41' *6.25'*
TENANT/ALLOCATED BUILDING SPACE FRONTAGE (FEET): 17' 3" x 2" = 34.50' *21.28'*

AWNING YES 1 NO _____ IS AWNING BACKLIT? YES _____ NO 1

HEIGHT OF AWNING: 4' 6" LENGTH OF AWNING: 5 1/2" DEPTH: 48"

IS THERE ANY COMMUNICATION, MESSAGE, TRADEMARK OR SYMBOL ON IT? YES 1 NO _____

IF YES, TOTAL S.F. OF PANELS WITH COMMUNICATIONS/MESSAGE/TRADEMARK/SYMBOL? 1.23 s.f.

A SITE SKETCH AND BUILDING SKETCH SHOWING EXACTLY WHERE EXISTING AND NEW SIGNAGE IS LOCATED MUST BE PROVIDED. SKETCHES AND/OR PICTURES OF PROPOSED SIGNAGE ARE ALSO REQUIRED.

SIGNATURE OF APPLICANT: [Signature] DATE: 1/2/03

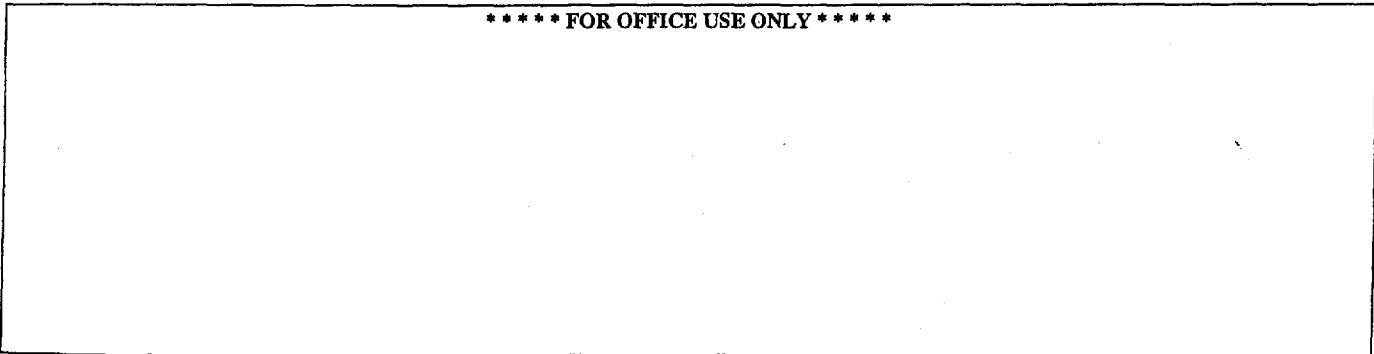

***** FOR OFFICE USE ONLY *****

bob

12/15/03

Dear Bob,

This is my letter of authorization and permission for improvements to the façade of 22 Exchange St.

I understand you will be replacing the canopy awning with a dome style of approximately the same overall dimensions.

I also agree to change the hanging sign from existing support in place.

TEN

~~XXXXXXXXXX~~ EXCHANGE LLC

[Handwritten Signature] S/M

Regards,
Josef Salex

Landlord

The Siquery

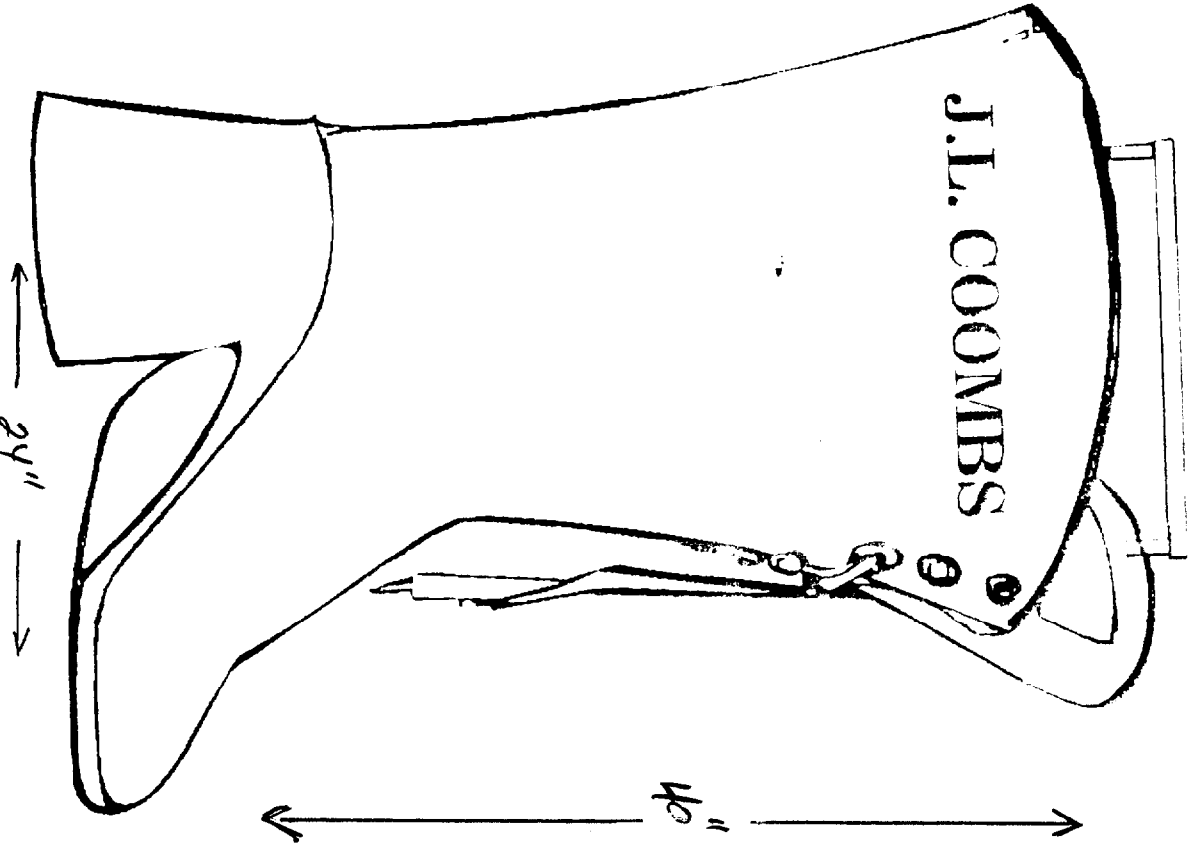

131

22 Exchange St.

JAN 15 2004

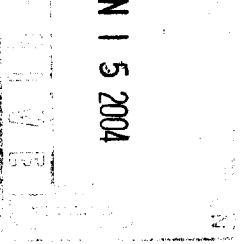

Certificate of Flame Resistance



REGISTERED APPLICATION CONCERN NO.

FA-39801

ISSUED BY

Glen Raven Custom Fabrics, LLC
1831 N. Park Avenue
Glen Raven, NC 27217

Size tested or manufactured

(Phone) 336/227-6211 (Fax) 336/229-4039

This is to certify that the materials described on the reverse side hereof have been flame-retardant treated (or are inherently nonflammable).

FOR Maine Bay Canvas ADDRESS 53 Industrial Way
CITY Portland, Maine STATE ME

Certificate is hereby made that: (Check "a" or "b")

(a) The article described on the reverse side of this Certificate has been treated with a flame-retardant chemical approved and registered by the State Fire Marshal and that the application of said chemical was done in conformance with the laws of the State of California and the Rules and Regulations of the State Fire Marshal.

Name of chemical used _____ Chem. Reg. No. _____
Method of application _____

(b) The article described on the reverse side hereof are made from a flame-resistant fabric or material registered and approved by the State Fire Marshal for such use.

Trade name of flame-resistant fabric or material used FR Sunbrella® Reg. No. FA-39801
The Flame Retardant Process Used will not **Be Removed By Washing**
(will or will not)

Name of Applicant or Production Superintendent
Glen Raven Custom Fabrics, LLC By Anna H. Livingston

GLEN RAVEN CUSTOM FABRICS, LLC

J.L. Coombs

**Coastal Signs
Freeport Maine**

Dear Bob,

Below is the list of materials that will be used to make your J.L. Coombs sign for Exchange St.

.750 MDO Board, painted, striped and decal.

Brackets to sign..... Zinc coated steel, wrap around with 1/4" through bolts.

Bracket to hang sign..... 36" Colonial, 1/4" steel with 2" backbone.

Since this bracket is mounted to steel beams, we will plan for 5/16", zinc coated, #16 bolts. However, we will prepare to tap and use thicker bolts if required. We will, at your insistence, install safety wires now in place although we do not anticipate they will be necessary for stability.

Carroll



ACORD ™ CERTIFICATE OF LIABILITY INSURANCE		DATE (MM/DD/YY) 12/31/03
PRODUCER MORSE PAYSON & NOYES INS P O BOX 406 PORTLAND, ME 04112 (888) 661-3038 XW985 700	THIS CERTIFICATE IS ISSUED AS A MATTER OF INFORMATION ONLY AND CONFERS NO RIGHTS UPON THE CERTIFICATE HOLDER. THIS CERTIFICATE DOES NOT AMEND, EXTEND OR ALTER THE COVERAGE AFFORDED BY THE POLICIES BELOW.	
INSURED J.L. COOMBS & CO. 262 US ROUTE 1 FREEPORT, ME 04032	INSURERS AFFORDING COVERAGE	
	INSURER A	The Charter Oak Fire Insurance Company
	INSURER B	The Travelers Indemnity Company Of Connecticut
	INSURER C	The Travelers Indemnity Company
	INSURER D	Travelers Casualty And Surety Company
	INSURER E	N/a

COVERAGES

THE POLICIES OF INSURANCE LISTED BELOW HAVE BEEN ISSUED TO THE INSURED NAMED ABOVE FOR THE POLICY PERIOD INDICATED. NOTWITHSTANDING ANY REQUIREMENT, TERM OR CONDITION OF ANY CONTRACT OR OTHER DOCUMENT WITH RESPECT TO WHICH THIS CERTIFICATE MAY BE ISSUED OR MAY PERTAIN, THE INSURANCE AFFORDED BY THE POLICIES DESCRIBED HEREIN IS SUBJECT TO ALL THE TERMS, EXCLUSIONS AND CONDITIONS OF SUCH POLICIES. AGGREGATE LIMITS SHOWN MAY HAVE BEEN REDUCED BY PAID CLAIMS.

NSR LTR	TYPE OF INSURANCE	POLICY NUMBER	POLICY EFFECTIVE DATE (MM/DD/YY)	POLICY EXPIRATION DATE (MM/DD/YY)	LIMITS
A	GENERAL LIABILITY <input checked="" type="checkbox"/> COMMERCIAL GENERAL LIABILITY <input type="checkbox"/> CLAIMS MADE <input checked="" type="checkbox"/> OCCUR GEN'L AGGREGATE LIMIT APPLIES PER: <input checked="" type="checkbox"/> POLICY <input type="checkbox"/> PRO-NEC <input type="checkbox"/> OCC	810-95573264-03	09/25/2003	09/25/2004	EACH OCCURRENCE \$ 1,000,000 PER CLAIM (any one file) \$ 1,000,000 PER POLICY (any one person) \$ 5,000 PERSONAL & ADJUDIC. \$ 1,000,000 GENERAL AGGREGATE \$ 2,000,000 PRODUCTS-COMPO-OPAGG \$ 2,000,000
B	AUTOMOBILE LIABILITY <input checked="" type="checkbox"/> ANY AUTO <input type="checkbox"/> ALL OWNED AUTOS <input type="checkbox"/> SCHEDULED AUTOS <input type="checkbox"/> HIRED AUTOS <input type="checkbox"/> NON-OWNED AUTOS	810-95573393-03	09/25/2003	09/25/2004	COMBINED YEARLY LIMIT (Each person) \$ 1,000,000 BODILY INJURY (Each person) \$ BODILY INJURY (Each person) \$ PROPERTY DAMAGE (Each person) \$ AUTOMOBILE LIABILITY (Each person) \$
	GARAGE LIABILITY <input type="checkbox"/> ANY AUTO				AUTO ONLY - BI ACCIDENT \$ OTHER THAN BI ACCIDENT \$ AUTO ONLY BI ACCIDENT \$
C	EXCESS LIABILITY <input checked="" type="checkbox"/> OCCUR <input type="checkbox"/> CLAIMS MADE <input type="checkbox"/> DEDUCTIBLE <input checked="" type="checkbox"/> RETENTION \$ 500	01E-572K6507-03	09/25/2003	09/25/2004	EACH OCCURRENCE \$ 1,000,000 AGIR RATE \$ 1,000,000 \$ \$ \$
D	WORKERS COMPENSATION AND EMPLOYERS' LIABILITY	1B-959Y9843-03	09/25/2003	09/25/2004	<input checked="" type="checkbox"/> HOSPITAL/TORY LIAB <input type="checkbox"/> OTHER BODILY INJURY - EMPLOYMENT \$ 100,000 BODILY INJURY - EMPLOYEE \$ 100,000 BODILY INJURY - POLICY LIMIT \$ 500,000
	OTHER				\$ \$ \$

DESCRIPTION OF OPERATIONS/LOCATIONS/VEHICLES/EXCLUSIONS ADDED BY ENDORSEMENT/SPECIAL PROVISIONS
 CERTIFICATE HOLDER IS NAMED ADDITIONAL INSURED - STATE OR POL SUBDIVISIONS-PERMITS

CERTIFICATE HOLDER <input checked="" type="checkbox"/> ADDITIONAL INSURED: INSURER LETTER: A	CANCELLATION SHOULD ANY OF THE ABOVE DESCRIBED POLICIES BE CANCELLED BEFORE THE EXPIRATION DATE THEREOF, THE ISSUING INSURER WILL ENDEAVOR TO MAIL 10 DAYS WRITTEN NOTICE TO THE CERTIFICATE HOLDER NAMED TO THE LEFT, BUT FAILURE TO DO SO SHALL IMPOSE NO OBLIGATION OR LIABILITY OF ANY KIND UPON THE INSURER ITS AGENTS OR REPRESENTATIVES.
CITY OF PORTLAND PO BOX 544 PORTLAND, ME 04112	AUTHORIZED REPRESENTATIVE

BUSINESSOWNERS PROPERTY COVERAGE SPECIAL FORM

Various provisions in this policy restrict coverage. Read the entire policy carefully to determine rights, duties and what is and is not covered.

Throughout this policy the words "you" and "your" refer to the Named Insured shown in the Declarations. The words "we", "us" and "our" refer to the Company providing this insurance.

Other words and phrases that appear in quotation marks have special meaning. Refer to SECTION G – PROPERTY DEFINITIONS.

A. COVERAGE – BUILDING, BUSINESS PERSONAL PROPERTY AND BUSINESS INCOME

We will pay for direct physical loss of or damage to Covered Property at the premises described in the Declarations caused by or resulting from a Covered Cause of Loss.

We will pay for the actual loss of Business Income you sustain due to the necessary "suspension" of your "operations" during the "period of restoration". The "suspension" must be caused by direct physical loss of or damage to property at the described premises. With respect to loss of or damage to personal property in the open or personal property in a vehicle, the described premises include the area within 1,000 feet of the site at which the described premises are located.

With respect to the requirements set forth in the preceding paragraph, if you occupy only part of the site at which the described premises are located, your premises means the portion of the building which you rent, lease or occupy and any area within the building or on the site at which the described premises are located, if that area services, or is used to gain access to, the described premises.

1. Covered Property

Covered Property, as used in this Coverage Form, means the type of property described in this section, **A.1.**, and limited in **A.2.**, Property and Costs Not Covered, if a Limit of Insurance is shown in the Declarations for that type of property.

a. Building, meaning the building or structure described in the Declarations, including:

- (1) Completed additions;
- (2) Fixtures, including outdoor fixtures;
- (3) Permanently attached:

(a) Machinery; and

(b) Equipment;

(4) Personal property owned by you that is used to maintain or service the building or structure or the premises, including:

(a) Fire extinguishing equipment;

(b) Outdoor furniture;

(c) Floor coverings;

(d) Appliances used for refrigerating, ventilating, cooking, dishwashing or laundering;

(e) Lawn maintenance and snow removal equipment; and

(f) Alarm systems;

(5) If not covered by other insurance:

(a) Alterations and repairs to the building or structure;

(b) Materials, equipment, supplies and temporary structures, on or within 1,000 feet of the described premises, used for making alterations or repairs to the building or structure.

b. Business Personal Property located in or on the buildings described in the Declarations or in the open (or in a vehicle) within 1,000 feet of the described premises, including:

(1) Property owned by you and used in your business;

(2) Property of others that is in your care, custody or control;

(3) Your use interest as tenant in improvements and betterments. Improvements and betterments are fix-

BUSINESSOWNERS

The most we will pay for loss or damage under this Extension is \$5,000 at each described premises.

k. Signs

Your Building or Business Personal Property insurance is extended to cover outdoor signs attached to the building or on or within 1,000 feet of the described premises.

i. Spoilage – Consequential Loss

Your Business Personal Property Insurance is extended to cover consequential loss to your business personal property caused by change in temperature or humidity. However, the change must result from a Covered Cause of Loss damaging the following types of equipment situated within the building described in the Declarations:

Refrigerating, cooling, humidifying, air-conditioning, heating, generating or converting power; and connections, supply or transmission lines and pipes associated with the above equipment.

m. Theft Damage to Rented Property

Your Business Personal Property insurance is extended to cover damage by theft or attempted theft to that part of a building you occupy and which contains:

- (1) Business Personal Property; or
- (2) Equipment within the building used for maintenance or service of the building.

We will not pay for damage:

- (a) Caused by or resulting from fire or explosion; or
- (b) To glass or glass lettering.

This Extension applies only to a building where you are a tenant and are liable for such damage.

n. Valuable Papers and Records – Cost of Research

The insurance under this extension will be in addition to the applicable Limits of Insurance.

Your Business Personal Property insurance is extended to apply to your costs to research, replace or restore the lost information on lost or damaged valuable papers and records, including those

which exist on electronic or magnetic media, for which duplicates do not exist. The most we will pay under this Extension is \$1,000 at each described premises.

B. EXCLUSIONS

1. We will not pay for loss or damage caused directly or indirectly by any of the following. Such loss or damage is excluded regardless of any other cause or event that contributes concurrently or in any sequence to the loss.

a. Ordinance or Law

The enforcement of any ordinance or law:

- (1) Regulating the construction, use or repair of any property; or
- (2) Requiring the tearing down of any building, including the cost of removing its debris.

This exclusion applies whether the loss results from:

- (a) An ordinance or law that is enforced even if the property has not been damaged; or
- (b) The increased costs incurred to comply with an ordinance or law in the course of construction, repair, renovation, remodeling or demolition of property, or removal of its debris, following a physical loss to that property.

b. Earth Movement

- (1) Earthquake, including any earth sinking, rising or shifting related to such event;
- (2) Landslide, including any earth sinking, rising or shifting related to such event;
- (3) Mine subsidence, meaning subsidence of a man-made mine, whether or not mining activity has ceased;
- (4) Earth sinking (other than sinkhole collapse), rising or shifting including soil conditions which cause settling, cracking or other disarrangement of foundations or other parts of realty. Soil conditions include contraction, expansion, freezing, thawing, erosion, improperly compacted soil and the action of water under the ground surface.

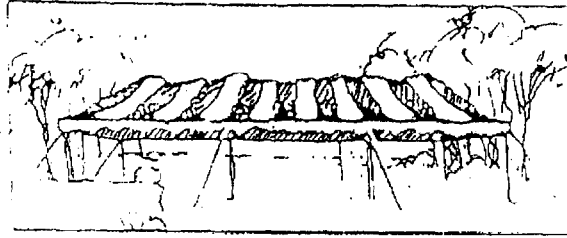

Maine Bay Canvas

53 Industrial Way, Portland, Maine 04103
207-878-8888

FAX # : (207) 878-5119

FAX COVER SHEET #

#####

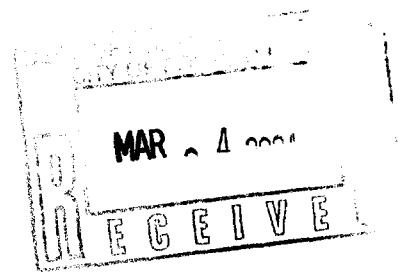
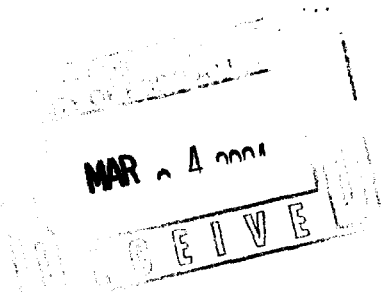

DATE: 3/24/04

TIME: 8:30

THIS SHEET IS PAGE # 1 OF 5 PAGES IN TOTAL

FROM THE DESK OF:

Jeanie Boorke

Party Tent Rentals • Custom Awnings • General Canvas Work



Frank Daleo

Maine Bay Canvas, Inc.

53 Industrial Way • Portland, Maine 04103
207-878-8888 • 1-800-287-8887 • Fax: 207-878-5119
www.mainebaycanvas.com

PHONE: 874 8716

MEMO:

I hope these specs help. please call if you have any questions.

Thanks Frank

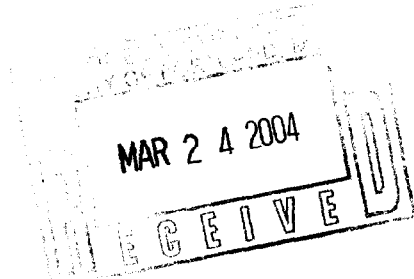

Sheet
16

Job No.	88051
Scale	N.T.S.
Date	OCT / 88
Check	J.D.
Drawn	W.M.W.

DEZ-SOLOMON ASSOCIATES, INC.
STRUCTURAL DESIGN
 903 N. MILITARY TRAIL, SUITE 222
 PALM BEACH GARDENS, FL 33410
 (407) 622-6900

allied / UNTEX
 (800) 882 - 5543 (800) 456 - 6282
 ENGINEERED AWNING DESIGNS

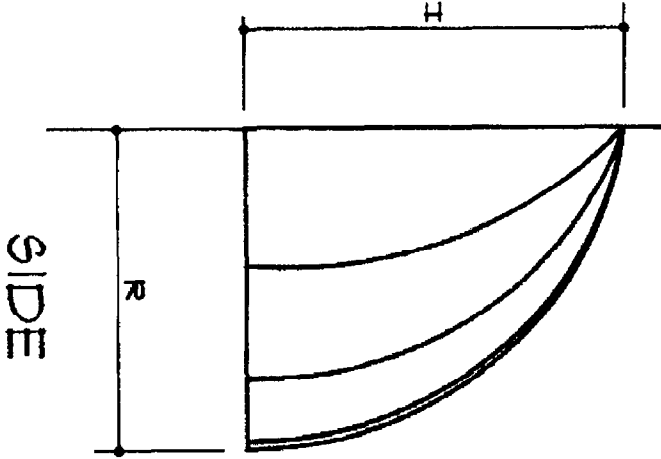

SIDE

MAR 24 2004
 E.I.V.E.
 ENGINEER

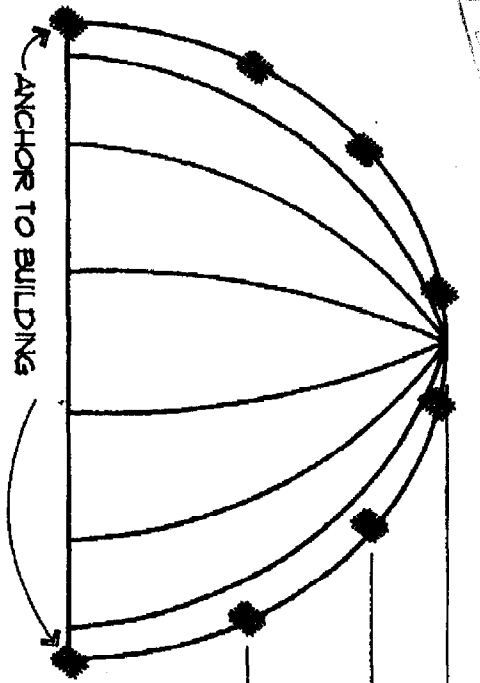

FRONT ELEVATION

8'	5'	3'
6	3.75	2.25
4	2.5	1.5
0	0	0

1 EQUAL ANGLES
α = 25.714°

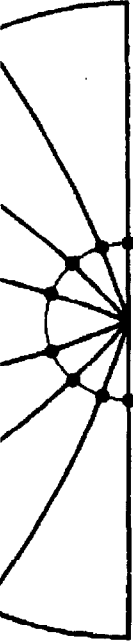

GENERAL NOTES:

1. FRAME MEMBERS SHALL BE WELDED TO EACH OTHER IN SUCH A WAY SO AS TO DEVELOP THE FULL STRENGTH OF THE MEMBERS JOINED. *
2. ALL FRAMEWORK IS ASSUMED TO BE COVERED WITH AWNING FABRIC WHICH TRANSMITS THE IMPOSED LOAD TO THE FRAMEWORK. FRAME MEMBER SIZES ARE BASED ON THE RESPONSE OF THE FRAME AT THE POINTS WHERE THE FABRIC IS ATTACHED.
3. ALL FRAMEWORK FABRICATION AND ASSEMBLY SHALL BE DONE IN ACCORDANCE WITH THE LATEST EDITION OF:
 - AMERICAN INSTITUTE OF STEEL CONSTRUCTION SPECIFICATION FOR THE DESIGN, FABRICATION AND ERECTION OF STEEL CONSTRUCTION
 - CODE OF STANDARD PRACTICE FOR BUILDINGS AND BRIDGES
 - INDUSTRIAL FABRICS ASSOCIATION INTERNATIONAL "AWNING DESIGN MANUAL"
 - AMERICAN WELDING SOCIETY "STRUCTURAL BUILDING CODE AWS D1.1"
4. IT SHALL BE THE RESPONSIBILITY OF THE DESIGNER TO DETERMINE WHICH LOAD SET, IF ANY, IS APPLICABLE TO HIS PARTICULAR PROJECT.
5. SEE CHAPTER EIGHT OF THE AWNING DESIGN MANUAL FOR DISCUSSION OF ANCHORAGES.
6. WHERE HORIZONTAL LOADING IS SIGNIFICANT REFER TO DISCUSSION IN CHAPTER SEVEN OF THE AWNING DESIGN MANUAL.
7. FRAME TABULATIONS ON THIS SHEET INCLUDE THE ADDITIONAL EFFECTS OF DEAD LOADS.
8. WALL ANCHORS TABULATED ON THIS SHEET ARE DETAILED ON OTHER DRAWINGS (SEE TABLE).
9. MEMBER SIZES IN THE TABLE ON THIS DRAWING ARE BASED ON:
 - (A) PIPE: ASTM A53, TYPE E OR S, SCHEDULE 40, GRADE B, $F_y = 35,000$ P.S.I.
 - (B) MILD STEEL TUBING: ROUND TUBING: ASTM A519, $F_y = 36,000$ P.S.I.; SQUARE TUBING: ASTM A513, $F_y = 36,000$ P.S.I.
 - (C) E.M.T.: LOW CARBON, DUCTILE STEEL, $F_y = 36,000$ P.S.I.
 - (D) HIGH STRENGTH STEEL TUBING: ASTM A135 AND A500, $F_y = 50,000$ P.S.I.
 - (E) ALUMINUM TUBING: ROUND TUBING: 6061-T6, SCHEDULE 40, $F_y = 40,000$ P.S.I.; SQUARE TUBING: 6063-T5, $F_y = 21,000$ P.S.I.
10. ALL FRAME SIZING IS BASED ON THE FOLLOWING WALL THICKNESS CRITERIA:
 - PIPE AND ROUND ALUMINUM TUBING - SCHEDULE 40
 - ROUND STEEL TUBING - UP TO AND INCLUDING 2" OR -0.085"
 - 2 1/8" OR LARGER - 0.120"
 - SQUARE STEEL TUBING - 1/2" NOM. DIM. - 0.065"
 - 3/4" UP TO AND INCLUDING 1 1/2" - 0.085"
 - 1 1/2" AND LARGER - 0.120"
 - SQUARE ALUMINUM TUBING - ALL 0.125"
 - ELEC. METALLIC TUBING - 3/4" NOM. SIZE - 0.049"
 - 1" NOM. SIZE - 0.087"
 - 1 1/4" UP TO AND INCLUDING 2" - 0.065"
 - 2 1/4" TO 3" NOM. SIZE - 0.072"
11. THIS DRAWING IS PART OF THE "AWNING DESIGN MANUAL" AND IS INTENDED TO BE USED AS ISSUED IN THE LATEST EDITION THEREOF. ANY REVISIONS MADE TO THIS DRAWING, EXCEPT AS ISSUED VIA THE UPDATES TO THE MANUAL, AND ANY DIFFERENCES BETWEEN THIS DRAWING AND THE ACTUAL SYSTEM CONSTRUCTED SHALL BE THE RESPONSIBILITY OF THE ONE AUTHORIZING THE CHANGE.

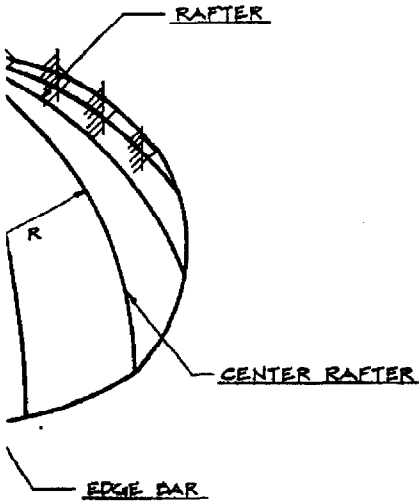

FRAME

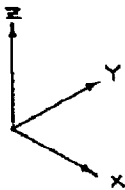

ORIENTATION OF COORDINATE AXIS

MAR 24 2004

RECEIVED

* ALUMINUM FRAMING MEMBER SIZES DO NOT TAKE INTO ACCOUNT THE POTENTIAL REDUCTION IN STRENGTH AT THE WELD, WHICH RESULTS IN SOME LOSS OF TEMPER IN THE PARENT METAL. THIS MUST BE ADDRESSED ON AN INDIVIDUAL BASIS.

DOME, CANTILEVERED FRAME DESIGN MANUAL	
ISSUED: NONE	REVISIONS BY:
DATE: 10-22-87	APPROVED BY: H.B.D.
AWNING DIVISION	
INDUSTRIAL FABRICS ASSOCIATION INTL.	
H.B. DAUGHERTY, P.E.	
WHITEHOUSE, OH (419) 877-0343	
IFAI-0009	

TABLE OF LOADS, MEMBER SIZES, ANCHORAGES & REACTIONS

		VERTICAL LOAD = 7.5 P.S.F. WIND LOAD = 25 P.S.F.						VERTICAL LOAD = 20 P.S.F. WIND LOAD = 16 P.S.F.						VERTICAL LOAD = 45 P.S.F. WIND LOAD = 10 P.S.F.															
		ROUND MILD STEEL TUBING		SQUARE MILD STEEL TUBING		PIPE		ROUND HIGH STRENGTH STEEL TUBING		SQUARE HIGH STRENGTH STEEL TUBING		PIPE		ROUND MILD STEEL TUBING		SQUARE MILD STEEL TUBING		PIPE		ROUND HIGH STRENGTH STEEL TUBING		SQUARE HIGH STRENGTH STEEL TUBING		PIPE					
HEIGHT (H)		9'-0"						9'-0"						9'-0"															
RADIUS (R)		9'-0"						9'-0"						9'-0"															
SPACING OF RAFTERS (S)		30"						30"						30"															
MEMBER SIZES	RAFTER	3/2	3/2	1/2	3/4	1/2	1/2	3/4	3/4	1	1/2	1	3/4	3/4	1	1/2	1	3/4	3/4	1	1/2	1	3/4	3/4	1				
	CENTER RAFTER	3/2	3/2	1/2	3/4	1/2	1/2	3/4	3/4	1	1/2	1	3/4	3/4	1	1/2	1	3/4	3/4	1	1/2	1	3/4	3/4	1				
	EDGE RAFTER	3/2	3/2	1/2	3/4	1/2	1/2	3/4	3/4	1	1/2	1	3/4	3/4	1	1/2	1	3/4	3/4	1	1/2	1	3/4	3/4	1				
	EDGE BAR	3/2	3/2	1/2	3/4	1/2	1/2	3/4	3/4	1	1/2	1	3/4	3/4	1	1/2	1	3/4	3/4	1	1/2	1	3/4	3/4	1				
WALL ANCHOR		SEE DRAWING IFA1-0002																											
REACTIONS AT SUPPORT	(A)	R _x = 30.5*	-152.0*	R _x = 80.8*	-105.0*	R _x = 215.4*	-59.5*																						
	(D)	R _y = 19.8*	-60.1*	R _y = +7.9*	-41.4*	R _y = 109.5*	-24.2*																						
	(E)	R _z = 2.0*	-77.6*	R _z = 14.5*	-58.7*	R _z = 70.9*	-36.2*																						
(D)	R _x	-21.1*	41.0*	R _x	48.9*	30.5*	R _x	-110.9*	16.5*																				
	R _y	-15.7*	18.8*	R _y	-30.0*	12.2*	R _y	-56.4*	5.4*																				
	R _z	0.7*	-6.6*	R _z	16.2*	-2.9*	R _z	29.6*	0.2*																				
(C)	R _x	-9.6*	-45.2*	R _x	-8.7*	-32.6*	R _x	-16.6*	-20.7*																				
	R _y	-9.6*	-6.5*	R _y	-5.2*	-6.2*	R _y	-9.0*	-5.5*																				
	R _z	6.0*	13.7*	R _z	0.6*	10.7*	R _z	14.5*	0.0*																				
(D)	R _x	-6.2*	-46.1*	R _x	-15.2*	-33.2*	R _x	-38.5*	-22.0*																				
	R _y	-4.0*	0.3*	R _y	-7.6*	5.9*	R _y	-13.6*	2.7*																				
	R _z	9.2*	12.5*	R _z	14.7*	10.9*	R _z	26.0*	9.5*																				
(E)	R _x	-70.0*	06.0*	R _x	-158.4*	103.2*	R _x	-109.4*	26.0*																				
	R _y	0.0*	0.0*	R _y	0.0*	0.0*	R _y	0.0*	0.0*																				
	R _z	114.2*	119.4*	R _z	220.2*	-78.0*	R _z	243.8*	-24.3*																				

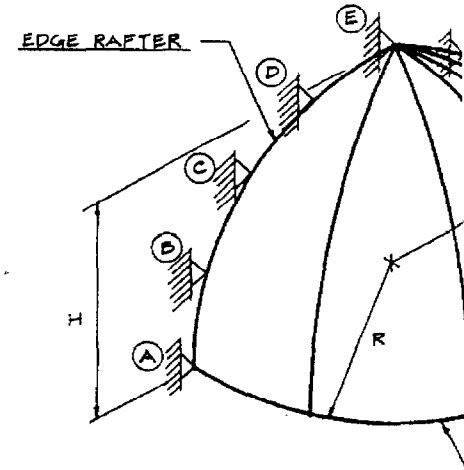

NOTE: REACTIONS SHOWN ABOVE ARE FOR RESPECTIVE LOADINGS; I.E., AT SUPPORT A, R_x = 30.5* IS FOR 7.5 P.S.F. ↓ LOADING; R_x = -152.0* IS FOR UP LOADS. (TYPICAL THROUGHOUT)

MAR 24 2004
RECEIVED

Figure 9