

Blade Sign

Quantity: 1 double-sided sign

- 1 2'x3' Blade Sign
 - 2"x4" wood frame
 - 5" tongue and groove wood boards
 - Graphics: frisketed painted logo - Althracite gray (RAL 7016), Farrow and Ball point No. 2003
- 2 Bracket details below
- 3 Mechanically fastened to building

Existing

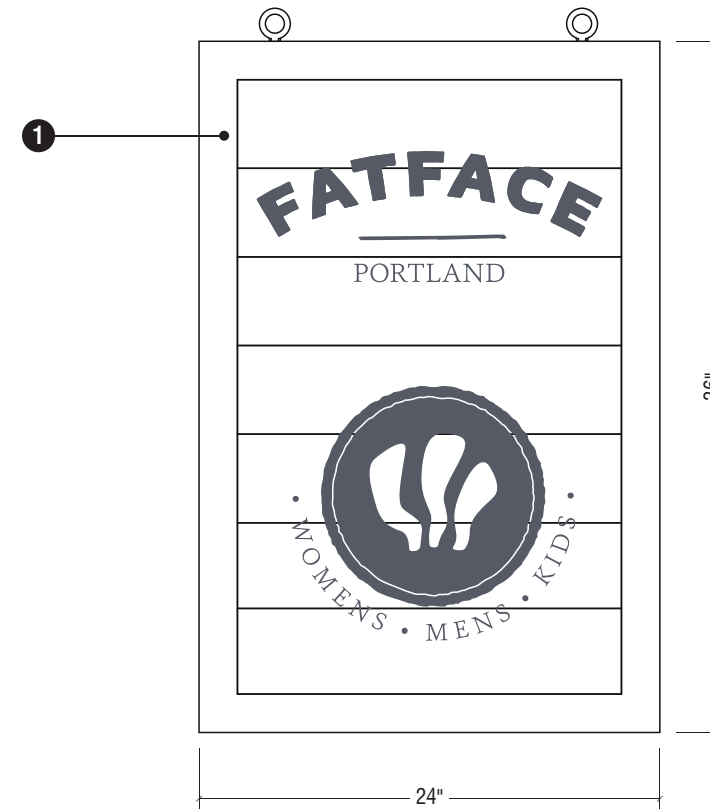
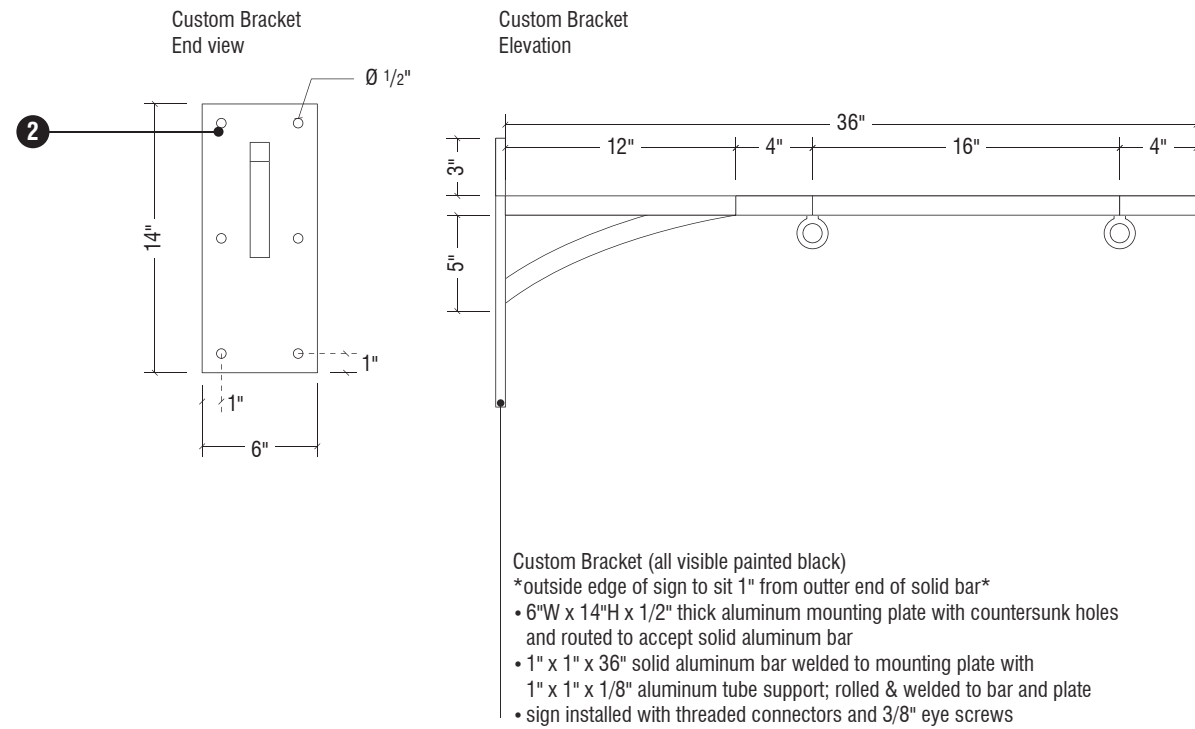

170 Liberty Street
Brockton, MA 02301
508-580-0094

SALES REPRESENTATIVE
Chrissy Ripley
PROJECT MANAGER
John "Lucky" Coelho
ACCOUNT COORDINATOR
Sheila Walsh
DESIGNER
MR

SCALE 10%

SHEET
01 of 03