

LOW VELOCITY DUCT LAYOUT DETAILS

SCALE: NONE

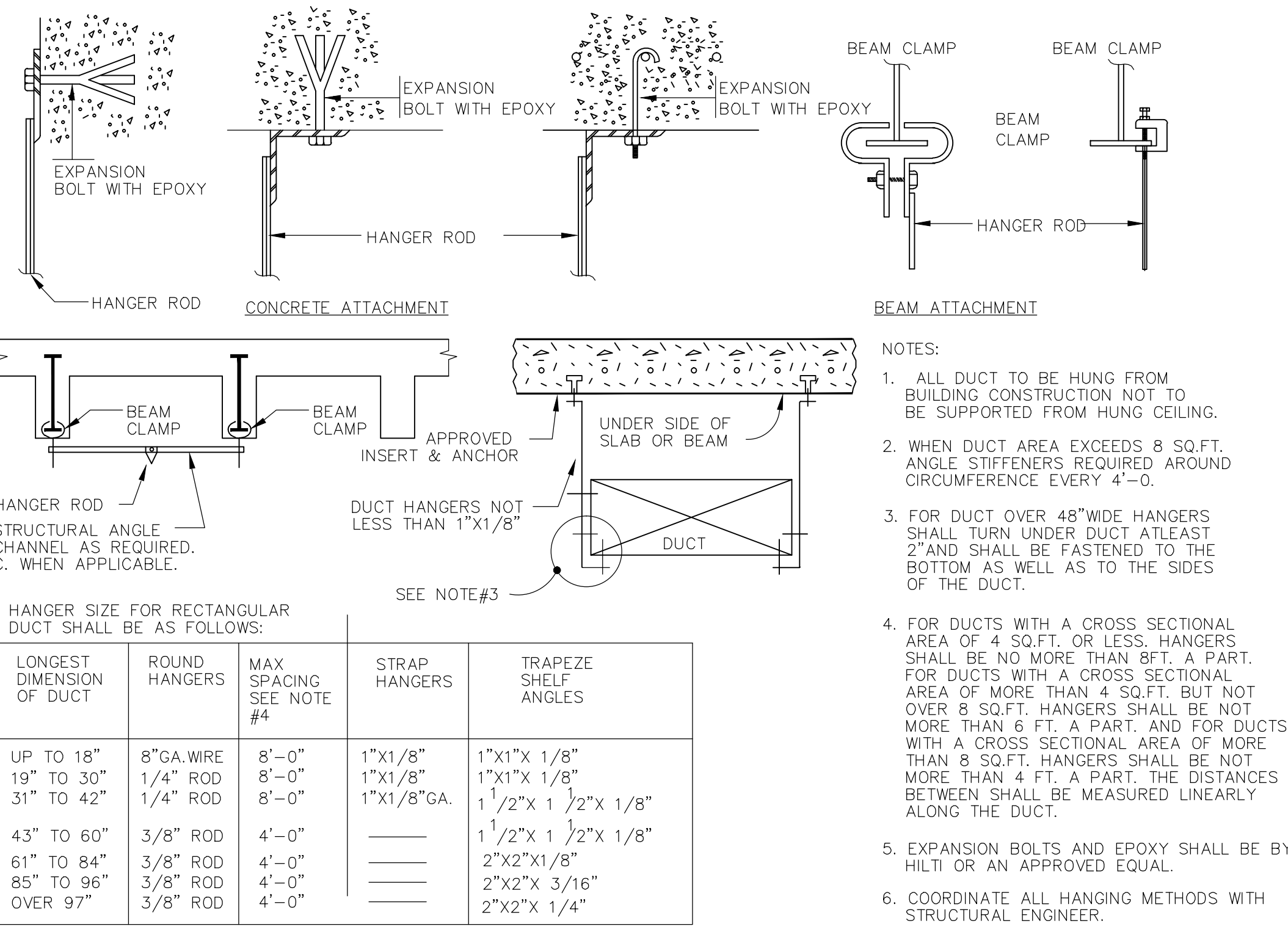

DUCT HANGING DETAIL

SCALE: NONE

LONGEST DIMENSION OF DUCT	ROUND HANGERS	MAX SPACING SEE NOTE #4	STRAP HANGERS	TRAPEZE SHELF ANGLES
UP TO 18"	8"GA. WIRE	8'-0"	1"X1/8"	1"X1"X 1/8"
19" TO 30"	1/4" ROD	8'-0"	1"X1/8"	1"X1"X 1/8"
31" TO 42"	1/4" ROD	8'-0"	1"X1/8"GA.	1 1/2"X 1 1/2"X 1/8"
43" TO 60"	3/8" ROD	4'-0"	---	1 1/2"X 1 1/2"X 1/8"
61" TO 84"	3/8" ROD	4'-0"	---	2"X2"X 1/8"
85" TO 96"	3/8" ROD	4'-0"	---	2"X2"X 3/16"
OVER 97"	3/8" ROD	4'-0"	---	2"X2"X 1/4"

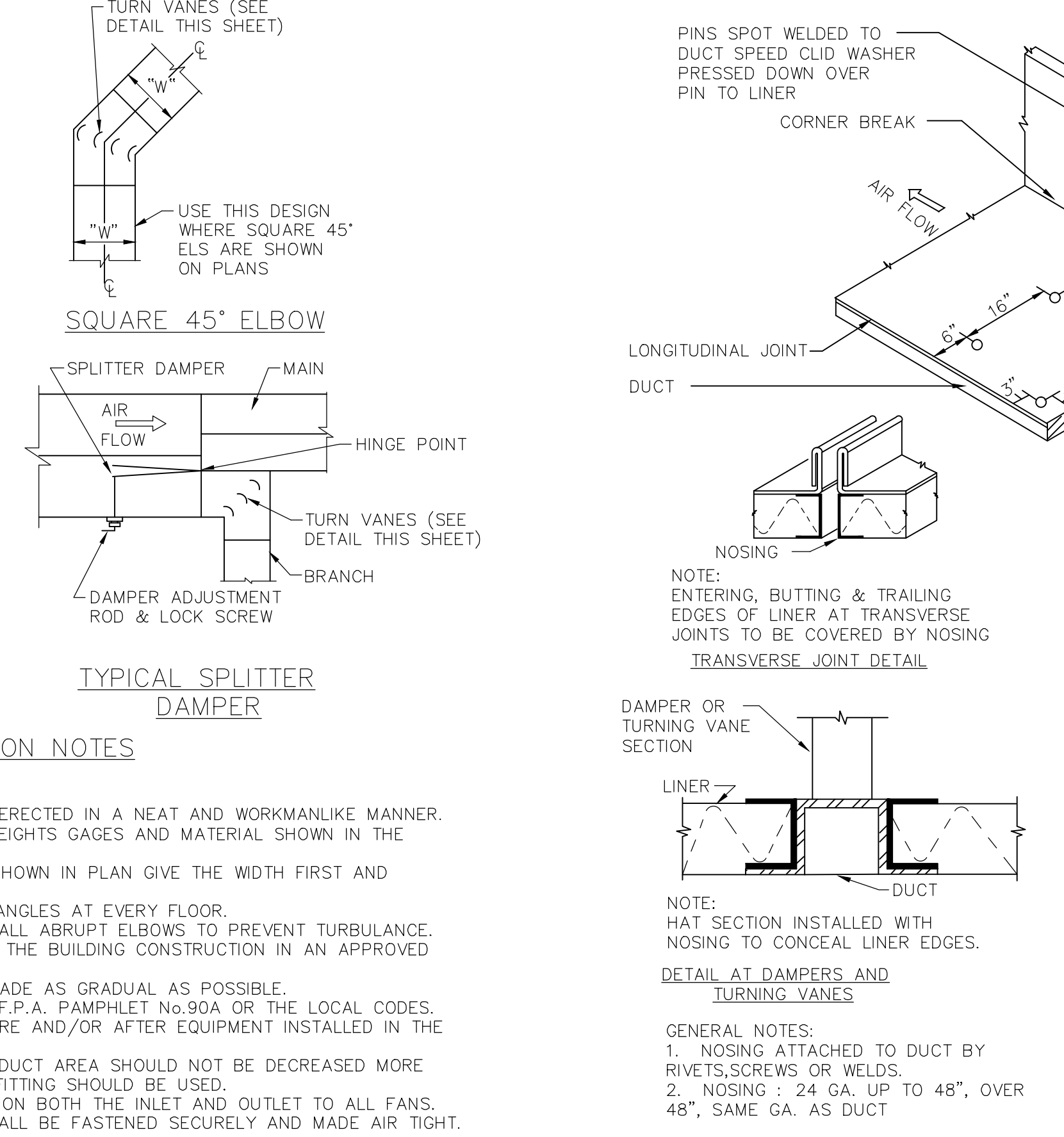

TURNING VANE DETAIL

SCALE: NONE

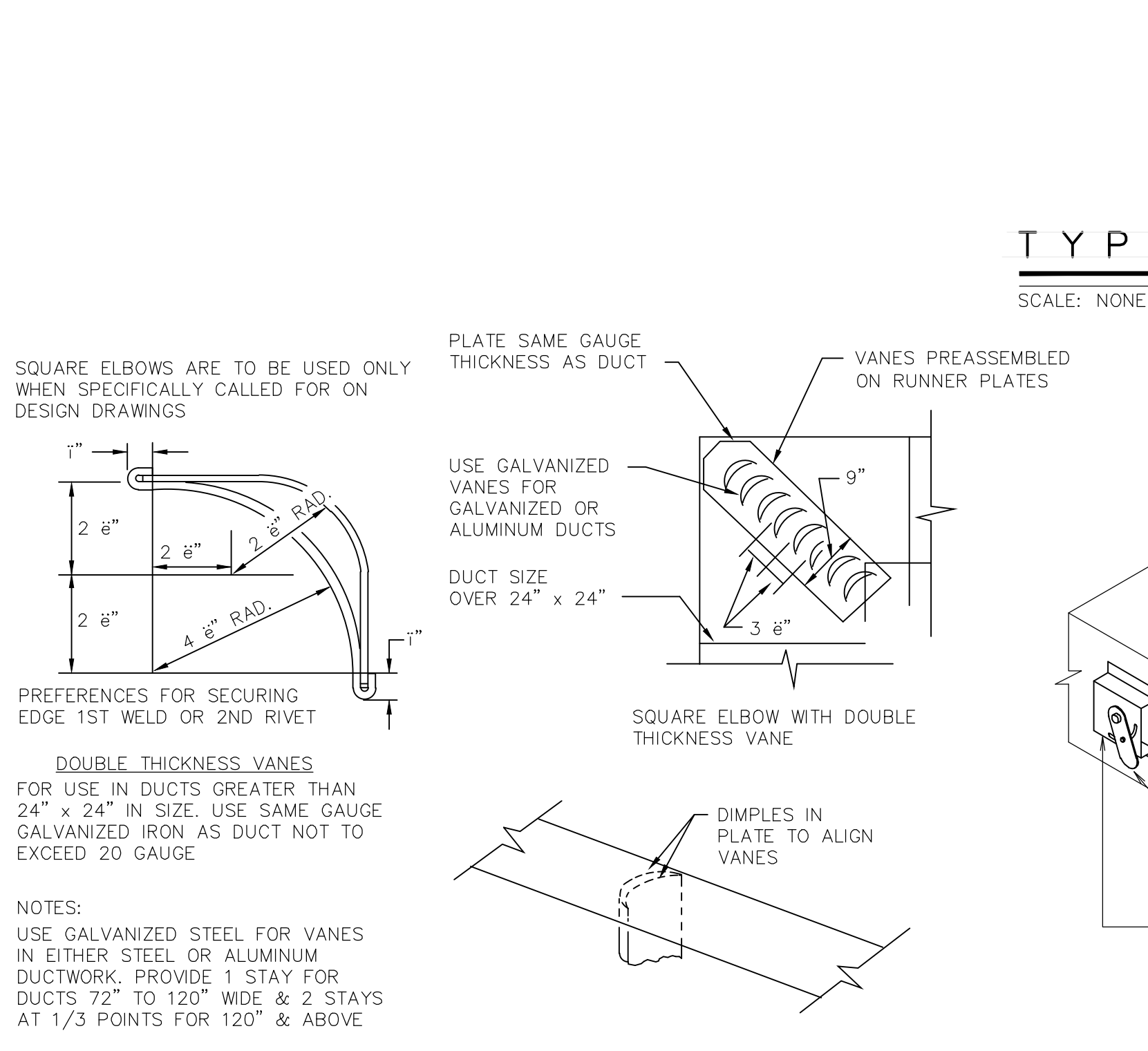

LOW PRESSURE BALANCING DAMPER

SCALE: NONE

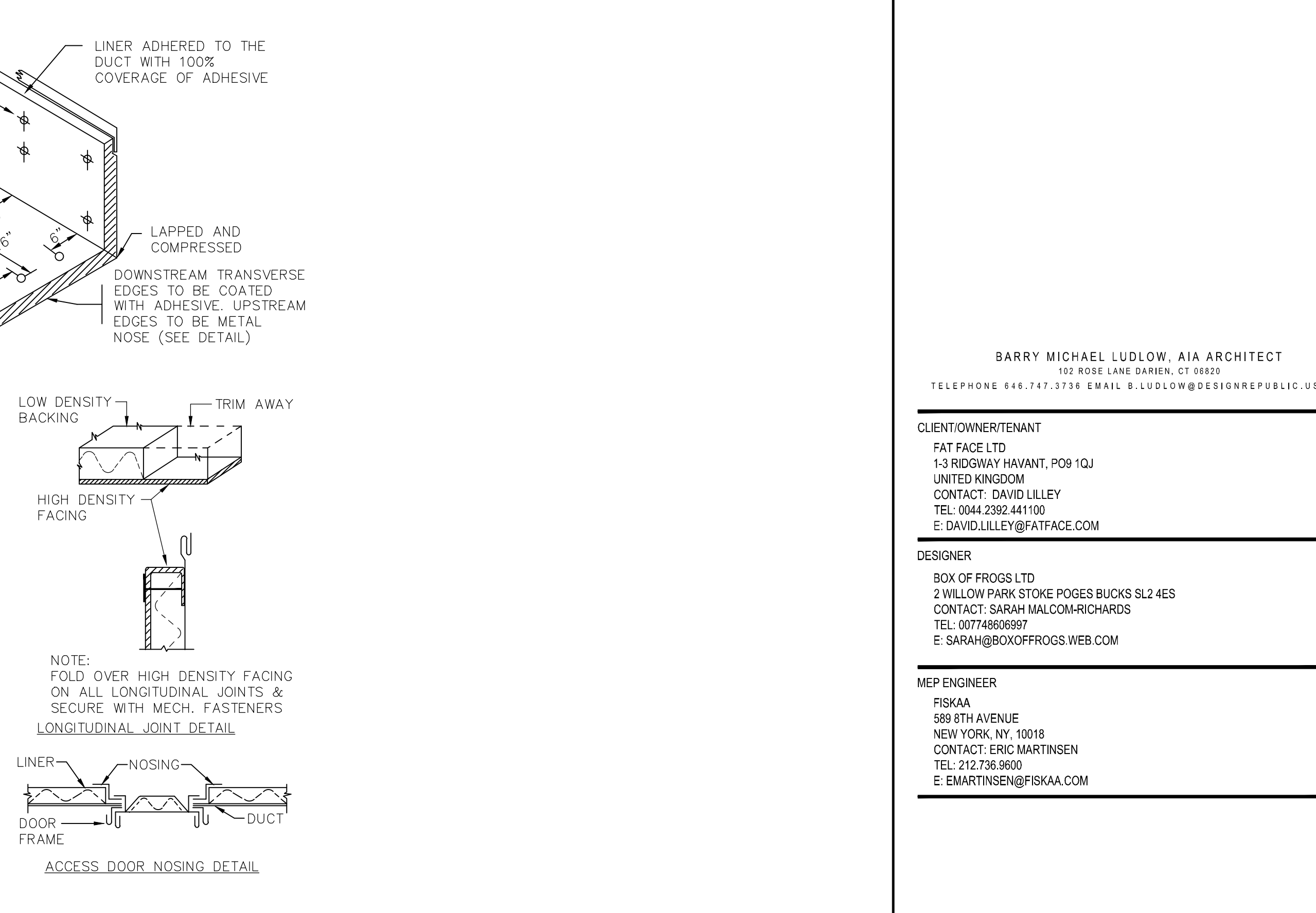

ACOUSTICAL DUCT LINER DETAIL

SCALE: NONE

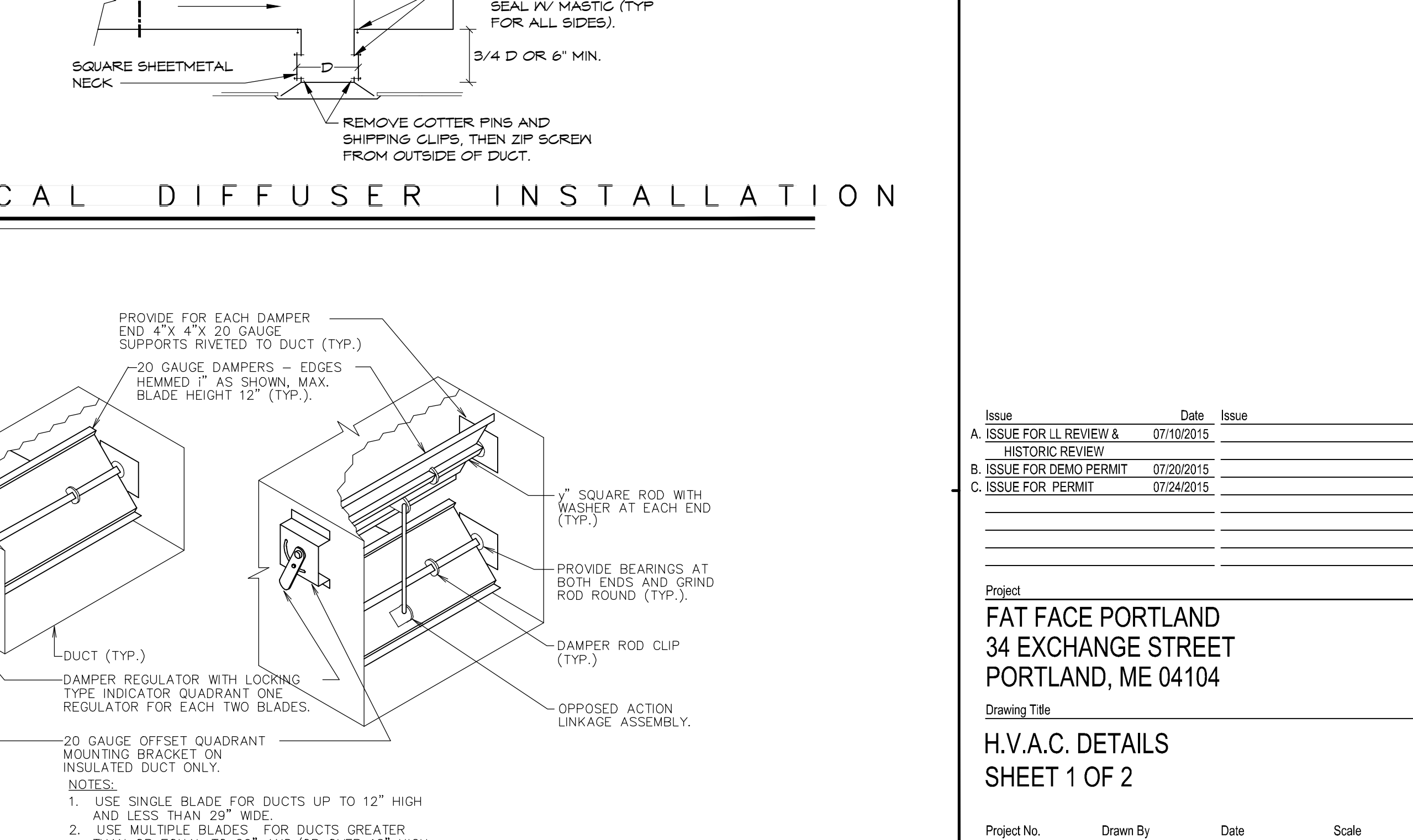

TYPICAL DIFFUSER INSTALLATION

SCALE: NONE

BARRY MICHAEL LUDLOW, AIA ARCHITECT
102 ROSE LANE DARIEN, CT 06825
TELEPHONE 646.747.3736 EMAIL B.LUDLOW@DESIGNREPUBLIC.US.COM

CLIENT/OWNER/TENANT
FAT FACE LTD
1-3 RIDGWAY HAVANT, PO9 1QJ
UNITED KINGDOM
CONTACT: DAVID LILLEY
TEL: 0044 2392 441100
E: DAVID.LILLEY@FATFACE.COM

DESIGNER
BOX OF FROGS LTD
2 WILLOW PARK STROKE POGES BUCKS SL2 4ES
CONTACT: SARAH MALCOM-RICHARDS
TEL: 007748606997
E: SARAH@BOXOFFROGS.WEB.COM

MEP ENGINEER
FISKAA
589 8TH AVENUE
NEW YORK, NY, 10018
CONTACT: ERIC MARTINSEN
TEL: 212.736.9600
E: EMARTINSEN@FISKAA.COM

Issue	Date	Issue	Date
A. ISSUE FOR LL REVIEW & HISTORIC REVIEW	07/10/2015		
B. ISSUE FOR DEMO PERMIT	07/20/2015		
C. ISSUE FOR PERMIT	07/24/2015		

Project
FAT FACE PORTLAND
34 EXCHANGE STREET
PORTLAND, ME 04104

H.V.A.C. DETAILS SHEET 1 OF 2

Project No.	Drawn By	Date	Scale
15.102.00			

Seal MS Floor(s)
Drawing No. **M-700**