

ADA COMPLIANCE DIAGRAMS

ACCESSIBILITY GUIDELINES

CONSTRUCTION SYMBOLS

DEMOLITION SYMBOLS

FINISH SYMBOLS

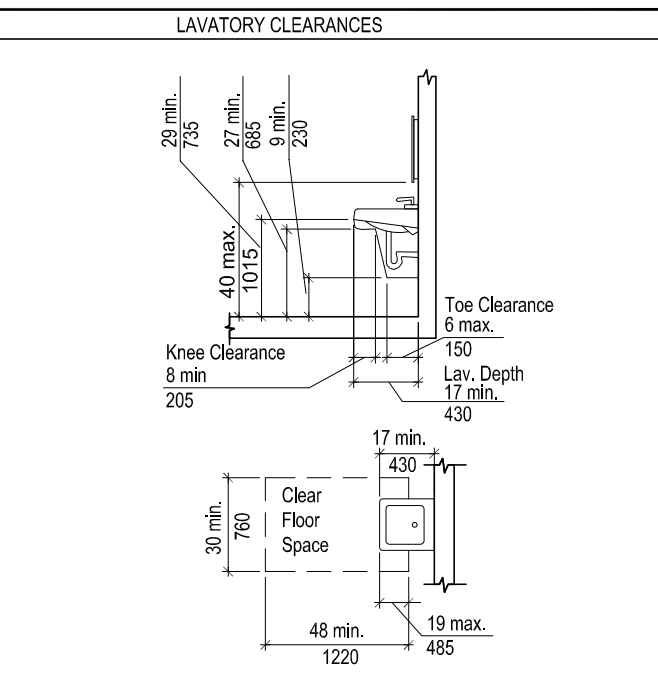
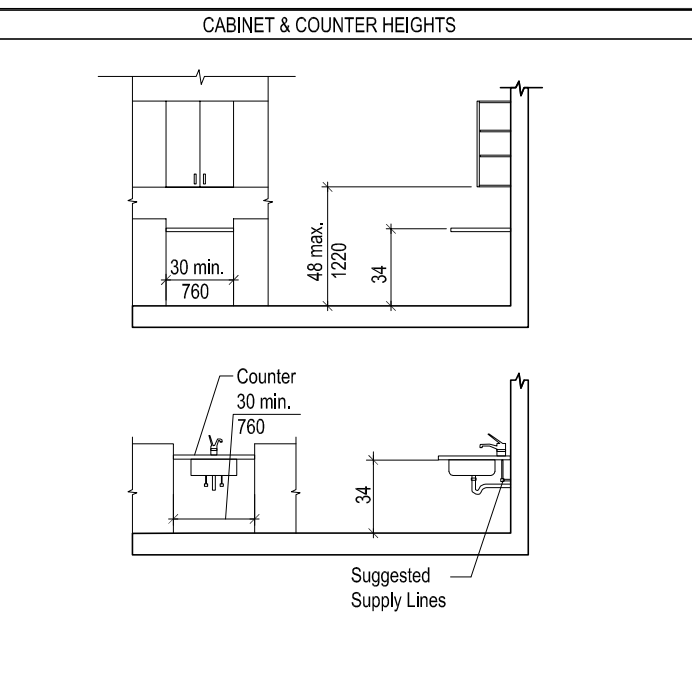
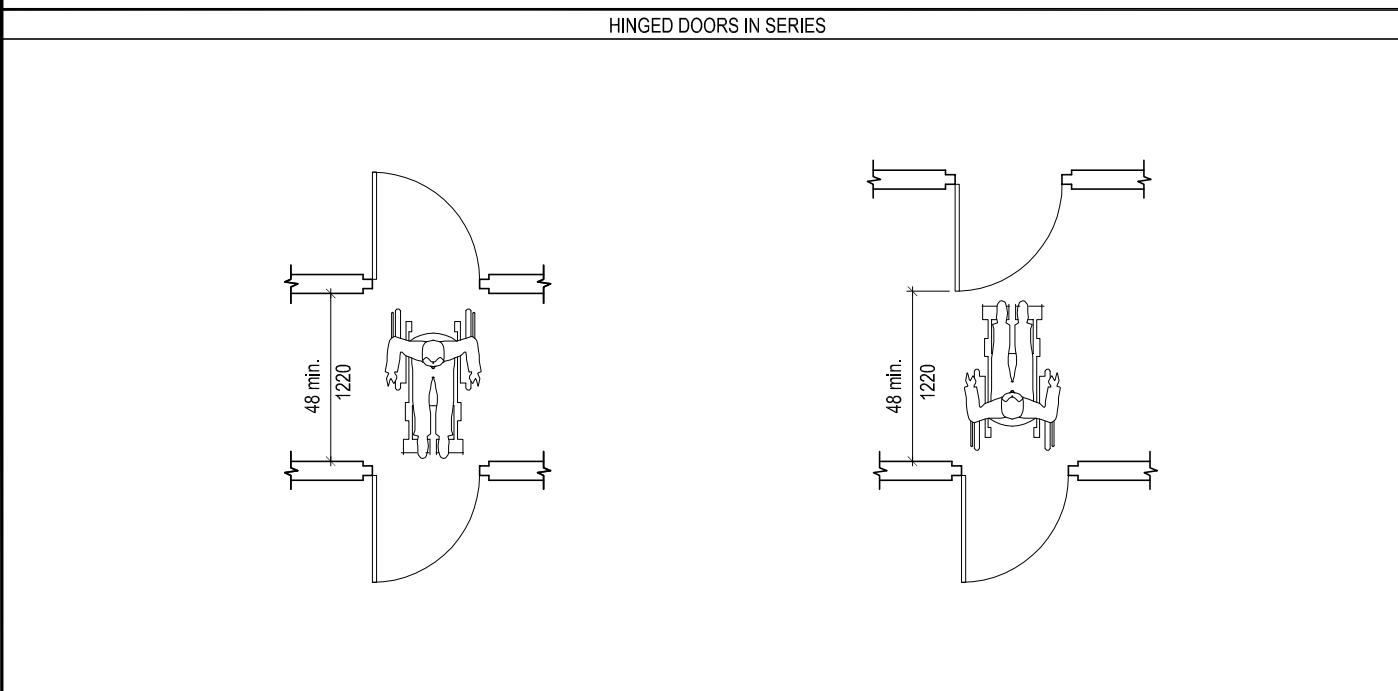

CONSTRUCTION SYMBOLS

- AREAS NOT IN CONTRACT
- EXISTING CONSTRUCTION TO REMAIN
- NEW PARTITION AND TYPE, REFER TO PARTITION SCHEDULE
- INDICATES MILLWORK
- INDICATES CENTERLINE
- INDICATES BREAKLINE
- INDICATES CLOUDED AREA OF REVISION, BULLETIN OR ADDENDUM
- INDICATES REVISION NUMBER AND AREA OF REVISION, BULLETIN OR ADDENDUM
- INDICATES LEVEL CHANGE
- INDICATES NEW DOOR/FRAME AND HARDWARE WITH 4" TYPICAL BETWEEN DOOR AND ADJACENT PARTITION, REFER TO DOOR SCHEDULE DRAWING(S)
- INDICATES DOOR TAG
- INDICATES ROOM / SPACE & NUMBER
- WALLS TO ALIGN
- DIMENSION TAG
- INDICATES ELEVATION
- INDICATES ENLARGED / DETAIL PLAN

DEMOLITION SYMBOLS

- EXISTING PARTITION TO BE REMOVED
- EXISTING DOOR TO REMAIN
- EXISTING DOOR TO BE REMOVED
- EXISTING MILLWORK TO BE REMOVED

FINISH SYMBOLS

- INDICATES WALL FINISH
- INDICATES BASE FINISH
- INDICATES FLOOR FINISH
- INDICATES CEILING FINISH
- INDICATES CHANGE IN FLOOR FINISH
- INDICATES CHANGE IN COLOR
- FLOOR TRANSITION DETAIL
- INDICATES GLASS FINISH
- INDICATES DIRECTION OF SPECIFIED MATERIAL
- FLOOR TILES TO ALIGN
- FLOOR TILES TO ALIGN

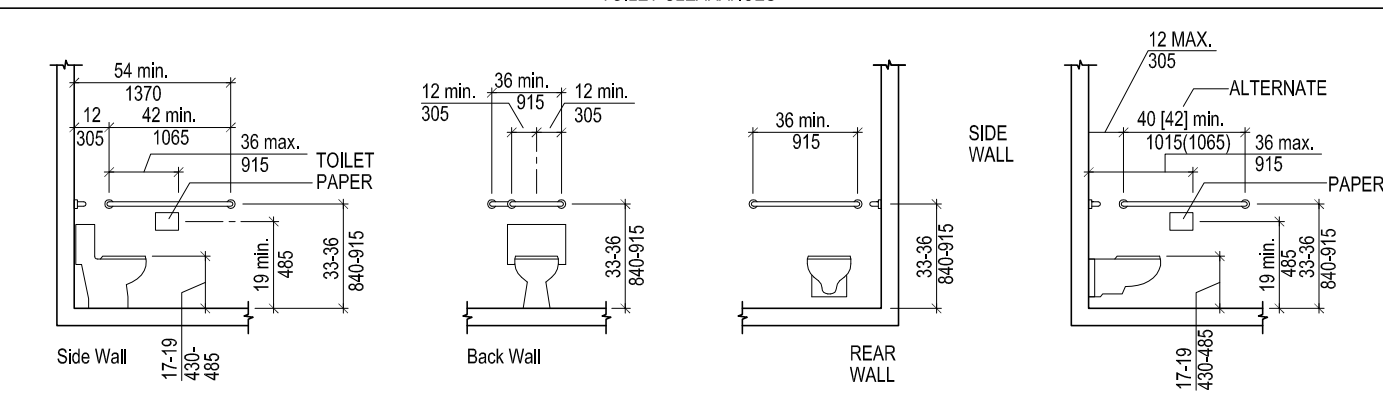
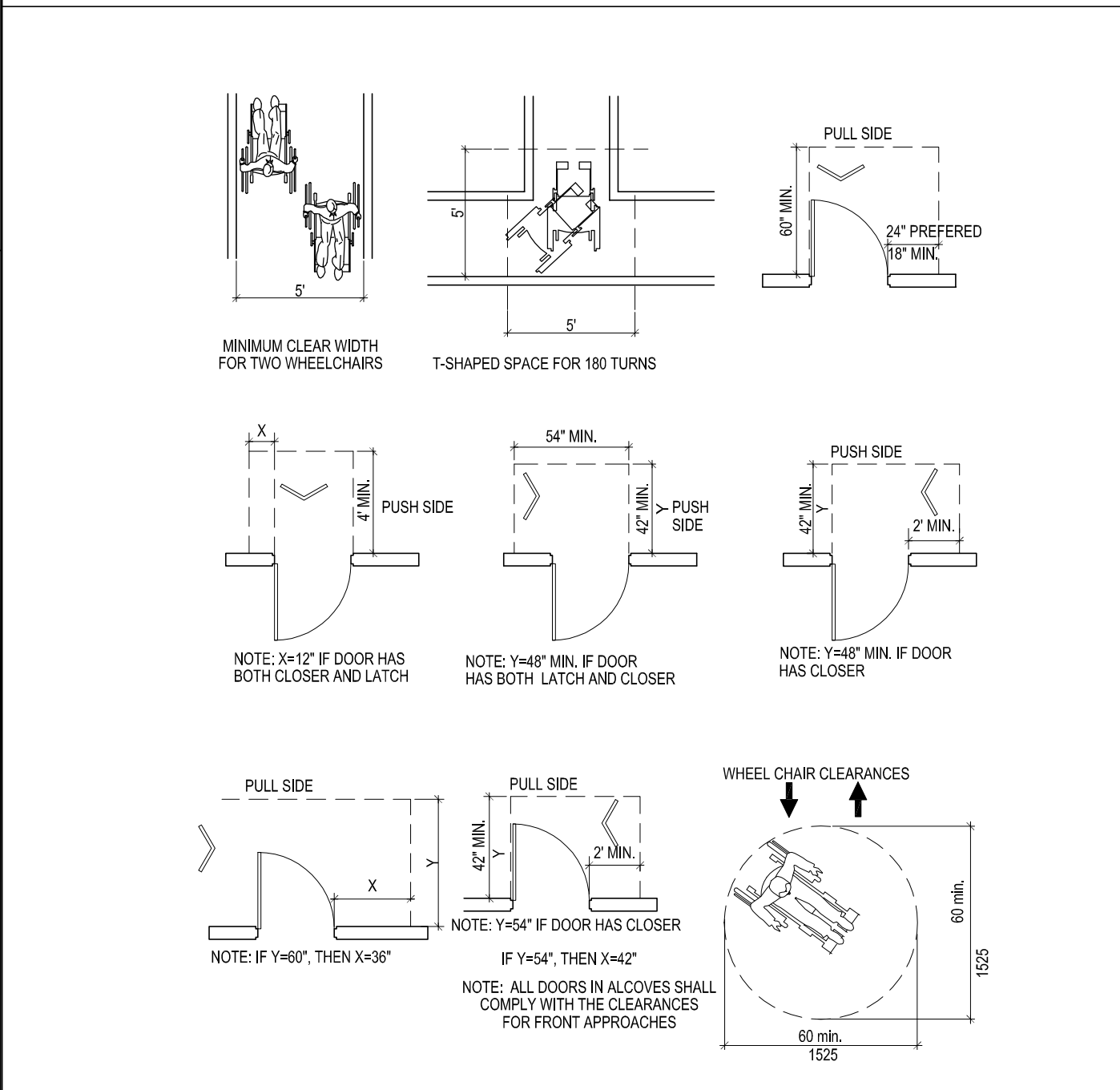

RCP SYMBOLS

- INDICATES NEW/EXIST GYPSUM BOARD SOFFIT & FASCIA, PAINTED.
- INDICATES CEILING HEIGHT & TYPE, ABOVE FINISHED FLOOR
- INDICATES CEILING FINISH
- SYMBOL INDICATES NEW LIGHT SWITCH @ 3'-2" AFF & 6" FROM EDGE OF DOOR FRAME. PROVIDE GANGED FACE PLATE AS REQUIRED. LEVITON DECORA. COLOR: WHITE. SEE ENGR. DWGS. FOR FIXTURES CONTROLLED BY SWITCHES OR SENSORS.
- INDICATES WALL MOUNTED 3-WAY LIGHT SWITCH
- INDICATES WALL MOUNTED DIMMER SWITCH. PROVIDE GANG PLATE AS RECD. LEVITON DECORA. WHITE.
- INDICATES CEILING MOUNTED JUNCTION BOX, VERIFY W/ ARCHITECT.
- INDICATES NEW RECESSED CEILING MOUNTED EXIT LIGHT MFR/MODEL NO. 'ATLIGHT' EDGELIT LED SERIES, 8" LETTERS, RED ON MIRROR MYLAR, WHITE. PROVIDE DIRECTIONAL ARROWS AS INDICATED.
- INDICATES FIRE EXTINGUISHER
- INDICATES A CHANGE IN MATERIAL, NEW TO OLD OR EVEN HEIGHT.
- INDICATES WALL MOUNTED EMERGENCY LIGHT FIXTURE, W/ BATTERY BACK-UP COORDINATE POWER REQUIREMENTS W/ MEP DOCUMENTS
- INDICATES CONCEALED FRAMELESS RECESSED EMERGENCY LIGHT, BLACK
- INDICATES CEILING-MOUNTED SECURITY CAMERA, WHITE
- INDICATES CEILING MOUNTED MOTION DETECTOR

POWER SYMBOLS

- POINT OF SALES SYSTEM CONSISTING OF (2) DUPEX SURGE PROTECTION (4)CAT 6 AT FLOOR
- RECESSED CLOCK QUAD OUTLETS ON DEDICATED CIRCUITS AS REQUIRED FOR VIDEO MONITORS. REFER TO SPECIFICATIONS RE: POWER REQUIREMENTS
- WALL MOUNTED JUNCTION BOX, REFER TO PLAN FOR LOCATION
- IN CEILING JUNCTION BOX (REFER TO REFLECTED CEILING PLAN FOR LOCATIONS)
- INDICATES FLOOR MOUNTED JUNCTION BOX
- INDICATES WALL MOUNTED QUAD ELECTRICAL RECEPTACLE
- INDICATES WALL MOUNTED DUPLEX ELECTRICAL RECEPTACLE
- INDICATES WALL MOUNTED GROUND FAULT INTERRUPT DUPLEX ELECTRICAL RECEPTACLE
- INDICATES NEW APPLIANCE OUTLET. COORDINATE W/ MANUFACTURER REQUIREMENTS.
- INDICATES FLOOR RECESSED ELECTRICAL RECEPTACLE
- INDICATES CEILING RECESSED ELECTRICAL RECEPTACLE
- INDICATES NEW WALL/FLOOR MOUNTED TELEPHONE OUTLET @ 14" AFF
- INDICATES NEW WALL/FLOOR MOUNTED CAT 5 DATA OUTLET/RECEPTACLE @ 14" AFF
- INDICATES NEW WALL/FLOOR MOUNTED CAT 6 DATA OUTLET/RECEPTACLE @ 14" AFF
- INDICATES NEW WALL/FLOOR MOUNTED DOUBLE GANG DATA OUTLET/RECEPTACLE @ 14" AFF
- WIRELESS ACCESS POINT
- INDICATES ELECTRIC DOOR BELL
- DOOR CHIME TIED TO DOOR BELL
- INDICATES ALARMHOLDUP BUTTON
- INDICATES ALARM KEYPAD
- INDICATES GLASS BREAK SENSOR. G.C. TO PROVIDE ASSOCIATED POWER AND WIRING
- INDICATES INDOOR WALL-MOUNTED SIREN
- INDICATES SECURITY CONTROL PANEL
- INDICATES DOOR CONTACT

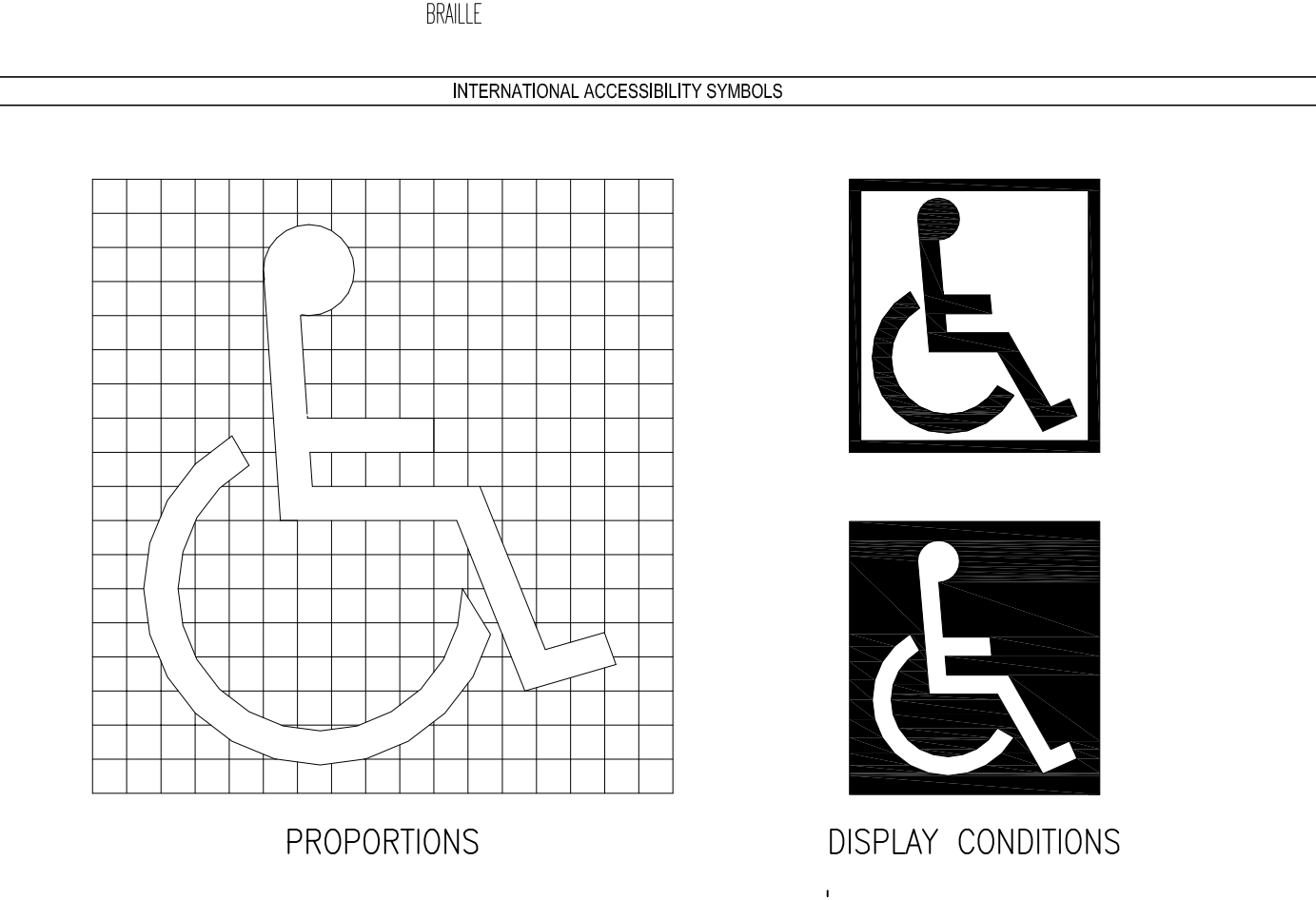
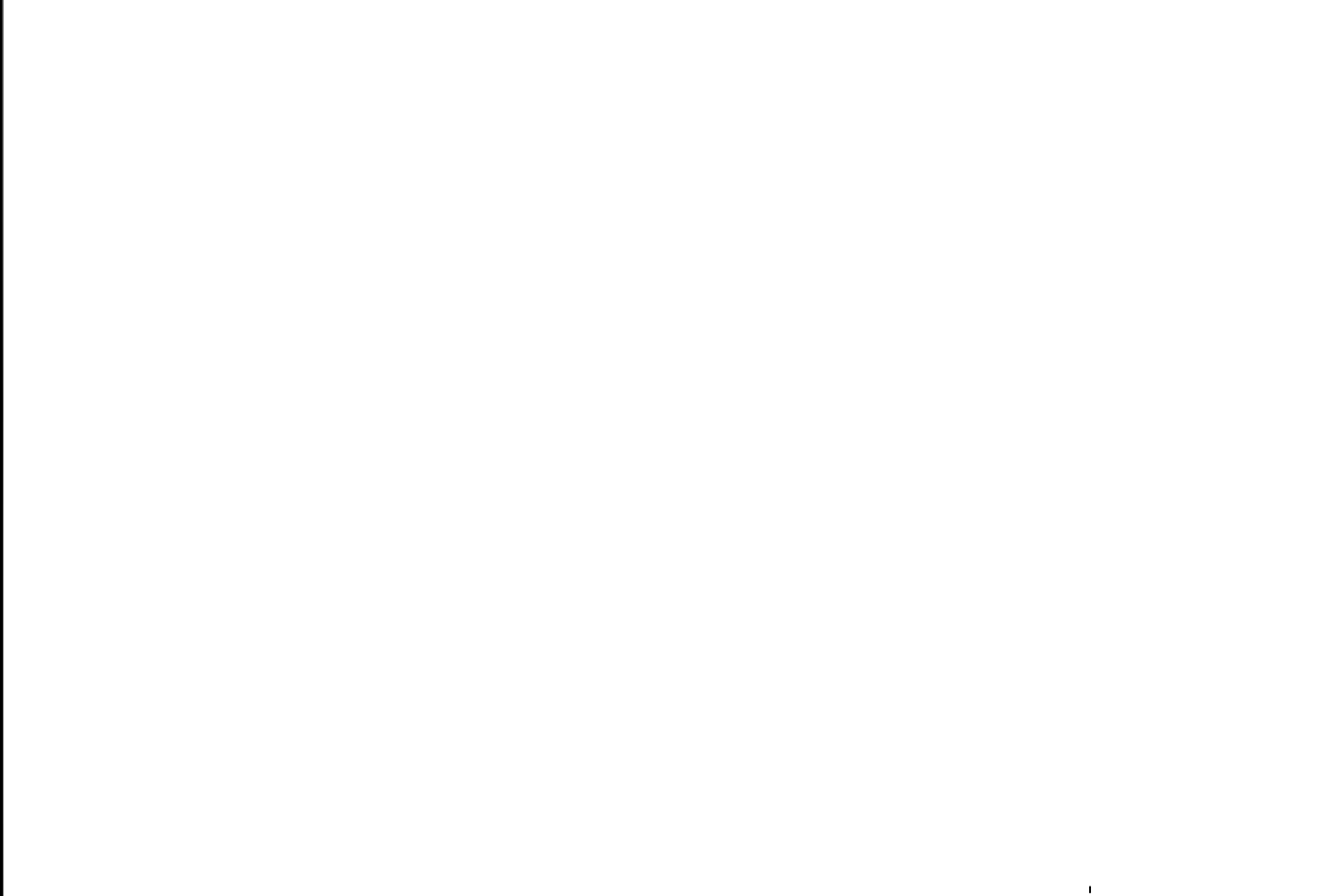
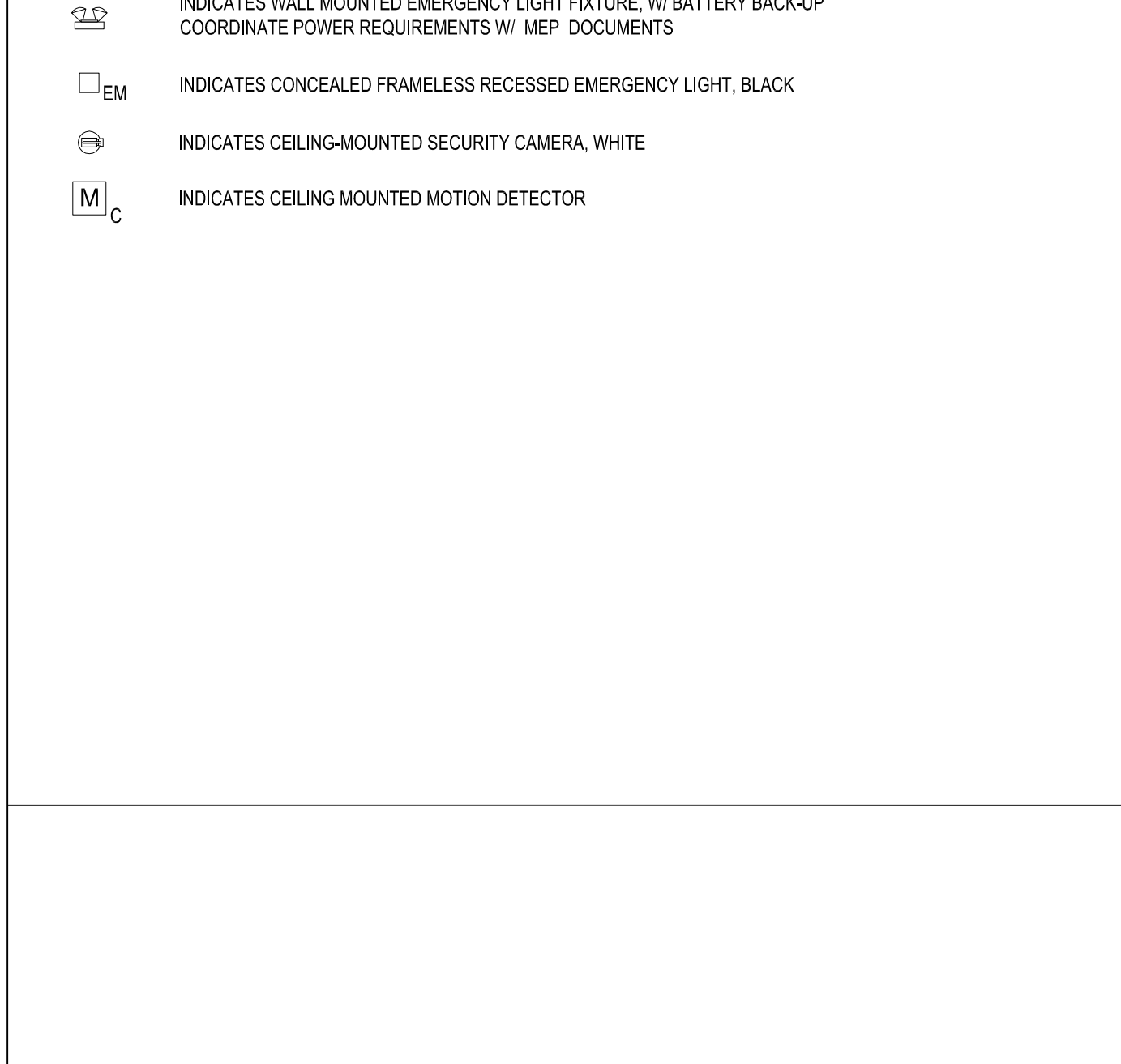
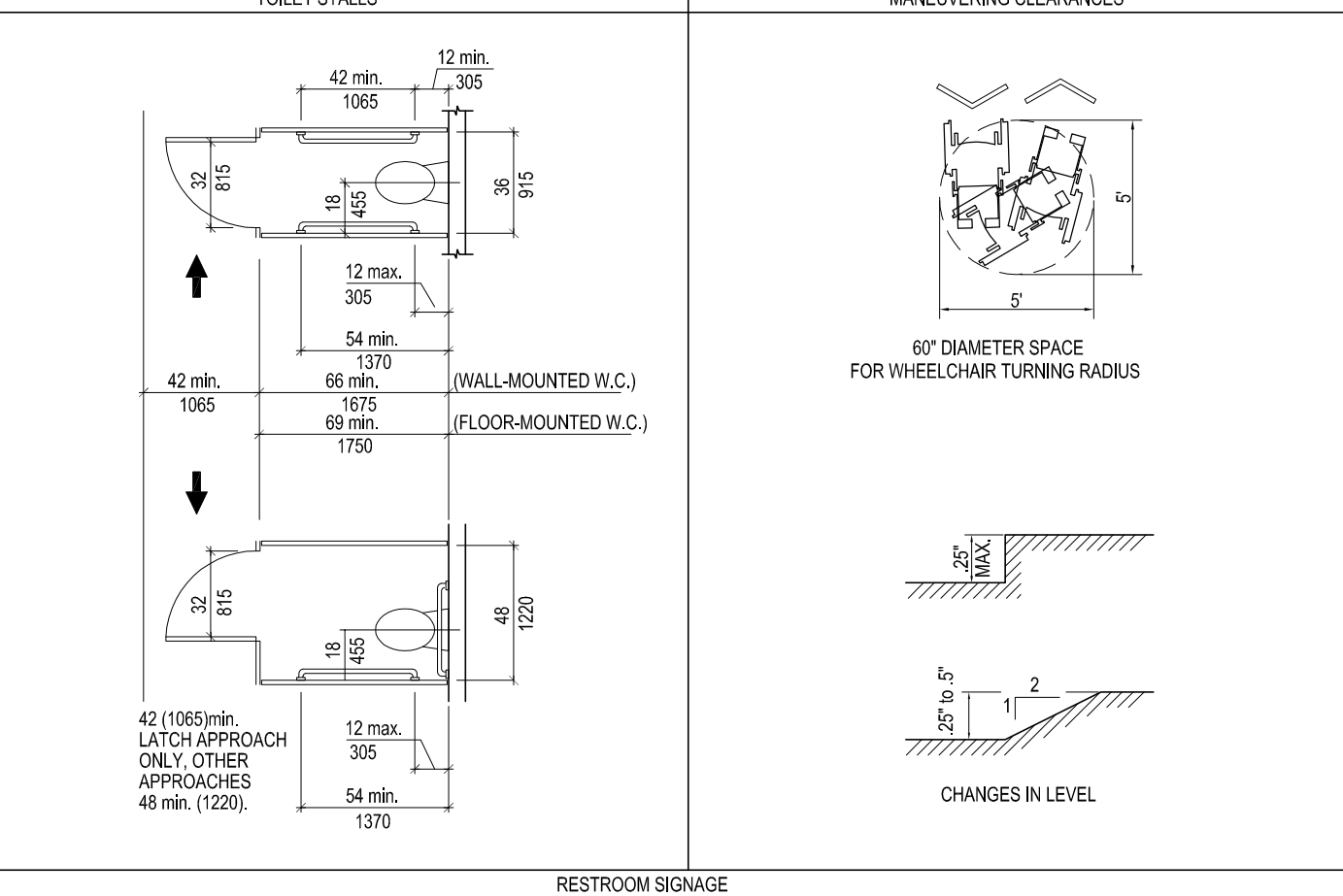
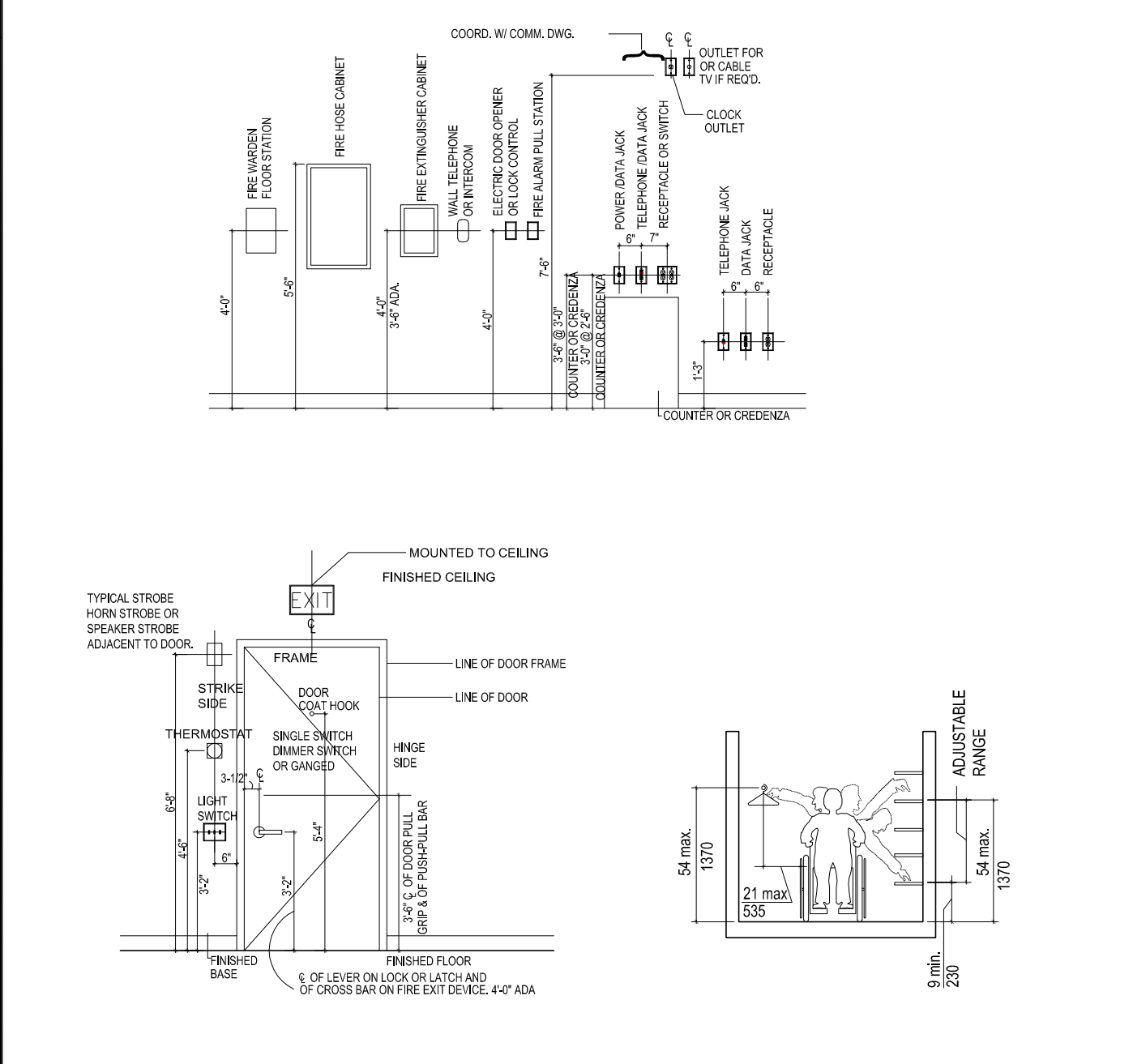

DESIGN REPUBLIC PARTNERS ARCHITECTS LLP
501 MADISON AVENUE 11th FLOOR NEW YORK, NEW YORK 10022
TELEPHONE 646 747 3730 WWW.DESIGNREPUBLIC.US.COM
ARCHITECTURE PLANNING DESIGN

CLIENT/OWNER/TENANT
FAT FACE LTD
1-3 RIDGWAY HAVANT, PO9 1QJ
UNITED KINGDOM
CONTACT: DAVID LILLEY
TEL: 00442392.441100
E: DAVID.LILLEY@FATFACE.COM

DESIGNER
BOX OF FROGS LTD
2 WILLOW PARK STROKE POGES BUCKS SL2 4ES
CONTACT: SARAH MALCOM-RICHARDS
TEL: 0074869997
E: SARAH@BOXOFFROGS.WEB.COM

MEP ENGINEER
FISKAA
589 8TH AVENUE
NEW YORK, NY, 10018
CONTACT: ERIC MARTINSEN
TEL: 212.736.9600
E: EMARTINSEN@FISKAA.COM

STRUCTURAL ENGINEER
ARMOUR UNSDERFER ENGINEERING INC. P.S.
555 116TH AVE. NE, SUITE 118
BELLEVUE WA 98004
CONTACT: BRIAN UNSDERFER
TEL: 425.614.0949
E: brianu@au-eng.com

Issue	Date	Issue	Date
A. ISSUE FOR HISTORIC REVIEW	07/01/15	Δ ISSUE FOR HISTORIC REVIEW	07/16/15
B. ISSUE FOR LL REVIEW/PRELIM	07/10/15		
PRICING			
C. ISSUE FOR DEMO PERMIT	07/20/15		

Project
FAT FACE PORTLAND
34 EXCHANGE STREET
PORTLAND, ME 04104
Drawing Title
ADA COMPLIANCE DIAGRAMS & SYMBOLS

Project No.	Drawn By	Date	Scale
5063.02			N/A

Seal
Drawing No.
G-005.00