

System No. W-L-1001
(Formerly System No. 147)
F Ratings - 1, 2, 3 and 4 Hr (See Items 2 and 3)
T Ratings - 0, 1, 2, 3, and 4 Hr (See Item 3)
L Rating At Ambient - less than 1 CFM/sq ft
L Rating At 400 F - less than 1 CFM/sq ft

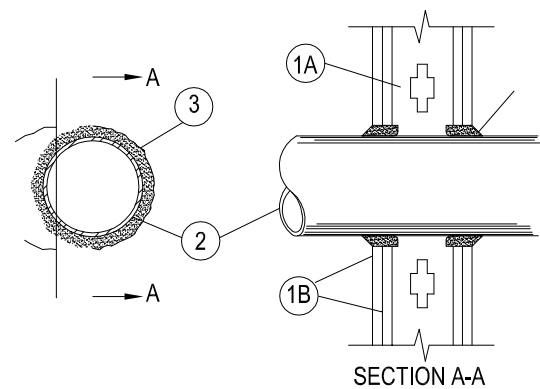

1. Wall Assembly - The 1, 2, 3 or 4 hr fire-rated gypsum wallboard/stud wall assembly shall be constructed of the materials and in the manner described in the individual U300 or U400 Series Wall or Partition Designs in the UL Fire Resistance Directory and shall include the following construction features:

- A. Studs - Wall framing may consist of either wood studs (max 2 hr fire rated assemblies) or steel channel studs. Wood studs to consist of nom 2 by 4 in. (51 by 102 mm) lumber spaced 16 in. (406 mm) OC with nom 2 by 4 in. (51 by 102 mm) lumber end plates and cross braces. Steel studs to be min 3-5/8 in. (92 mm) wide by 1-3/8 in. (35 mm) deep channels spaced max 24 in. (610 mm) OC.
- B. Gypsum Board - Nom 1/2 or 5/8 in. (13 or 16 mm) thick, 4 ft. (122 cm) wide with square or tapered edges. The gypsum wallboard type, thickness, number of layers, fastener type and sheet orientation shall be as specified in the individual U300 or U400 Series Design in the UL Fire Resistance Directory. Max diam of opening is 26 in. (660 mm).

- 2. Through Penetrant - One metallic pipe, conduit or tubing installed either concentrically or eccentrically within the firestop system. The annular space between pipe, conduit or tubing and periphery of opening shall be min of 0 in. (0 mm) (point contact) to max 2 in. (51 mm). Pipe, conduit or tubing to be rigidly supported on both sides of wall assembly. The following types and sizes of metallic pipes, conduits or tubing may be used:
 - A. Steel Pipe - Nom 24 in. (610 mm) diam (or smaller) Schedule 10 (or heavier) steel pipe.
 - B. Iron Pipe - Nom 24 in. (610 mm) diam (or smaller) service weight (or heavier) cast iron soil pipe, nom 12 in. (305 mm) diam (or smaller) or Class 50 (or heavier) ductile iron pressure pipe.
 - C. Conduit - Nom 6 in. (152 mm) diam (or smaller) steel conduit or nom 4 in. (102 mm) diam (or smaller) steel electrical metallic tubing.
 - D. Copper Tubing - Nom 6 in. (152 mm) diam (or smaller) Type L (or heavier) copper tubing.
 - E. Copper Pipe - Nom 6 in. (152 mm) diam (or smaller) Regular (or heavier) copper pipe.
 - F. Through Penetrating Product - Flexible Metal Piping - The following types of steel flexible metal gas piping may be used:

- 1. Nom 2 in. (51 mm) diam (or smaller) steel flexible metal gas piping. Plastic covering on piping may or may not be removed on both sides of floor or wall assembly.
- OMEGA FLEX INC

- 2. Nom 1 in. (25 mm) diam (or smaller) steel flexible metal gas piping. Plastic covering on piping may or may not be removed on both sides of floor or wall assembly.
- TITEX CORP
A BUNDY CO

- 3. Nom 1 in. (25 mm) diam (or smaller) steel flexible metal gas piping. Plastic covering on piping may or may not be removed on both sides of floor or wall assembly.
- WARD MFG INC

- 4. Fill/Void or Cavity Materials - Caulk or Sealant - Min 5/8, 1-1/4, 1-7/8 and 2-1/2 in. (16, 32, 48 and 64 mm) thickness of caulk for 1, 2, 3 and 4 hr rated assemblies, respectively, applied within annulus, flush with both surfaces of wall. Min 1/4 in. (6 mm) diam bead of caulk applied to gypsum board/penetrant interface at point contact location on both sides of wall. The hourly F Rating of the firestop system is dependent upon the hourly fire rating of the wall assembly in which it is installed, as shown in the following table. The hourly T Rating of the firestop system is dependent upon the type or size of the pipe or conduit and the hourly fire rating of the wall assembly in which it is installed, as tabulated below:

| Max Pipe or Conduit Diam. in. (mm) | Annular Space (in) | F Rating hr | T Rating hr |
|------------------------------------|--------------------|-------------|-------------|
| 1 (25) | 0 - 3/16 | 1 OR 2 | 0+, 1 OR 2 |
| 1 (25) | 1/2 - 1/2 | 3 OR 4 | 3 OR 4 |
| 4 (102) | 0 - 1 1/2 | 1 OR 2 | 0 |
| 6 (152) | 1/2 - 1/2 | 3 OR 4 | 0 |
| 12 (305) | 3/8 - 3/8 | 1 OR 2 | 0 |

+When copper pipe is used, T Rating is 0 hr.
3M COMPANY - CP 25WB+ caulk or FB-3000 WT sealant.
*Bearing the UL Classification Marking

System No. W-L-2002
Formerly System No. 148
F Ratings - 1, 1 1/2, and 2 Hr (See Item 3)
T Ratings - 3/4, 1, 1 1/2 and 2 Hr (See Item 3)
L Rating At Ambient - 7 CFM/sq ft (See Item 3C)
L Rating At 400 F - 1 CFM/sq ft (See Item 3C)

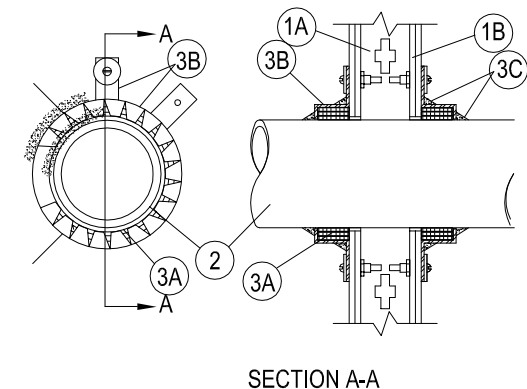

1. Wall Assembly - The 1 or 2 hr fire-rated gypsum wallboard/stud wall assembly shall be constructed of the materials and in the manner described in the individual U300, U400 or U400 Series Wall or Partition Design in the UL Fire Resistance Directory and shall include the following construction features:

- A. Studs - Wall framing may consist of either wood studs or steel channel studs. Wood studs to consist of nom 2 in. by 4 in. (51 mm by 102 mm) lumber spaced 16 in. (406 mm) OC. Steel studs to be min 3-5/8 in. (92 mm) wide by 1-3/8 in. (35 mm) deep channels spaced max 24 in. (610 mm) OC.
- B. Gypsum Board - 5/8 in. (16 mm) thick, 4 ft (122 cm) wide with square or tapered edges. The gypsum wallboard type, thickness, number of layers, fastener type and sheet orientation shall be as specified in the individual U300 or U400 Series Design in the UL Fire Resistance Directory. Max diam of opening is 7 in. (178 mm).

- 2. Nonmetallic Pipe or Conduit - One nonmetallic pipe or conduit is centered within the firestop system. Pipe or conduit to be installed near center of stud cavity width and to be rigidly supported on both sides of wall. The following types and sizes of nonmetallic pipes or conduit may be used:
 - A. Nom 6 in. (152 mm) diam (or smaller) Schedule 40 solid-core polyvinyl chloride (PVC) pipe for use in closed (process or supply) or vented (drain, waste or vent) piping systems.
 - B. Nom 4 in. (102 mm) diam (or smaller) Schedule 40 cellular core polyvinyl chloride (PVC) pipe for use in closed (process or supply) or vented (drain, waste or vent) piping systems.
 - C. Nom 4 in. (102 mm) diam (or smaller) Schedule 40 solid-core acrylonitrile-butadiene-styrene (ABS) pipe for use in closed (process or supply) or vented (drain, waste or vent) piping systems.
 - D. Nom 4 in. (102 mm) diam (or smaller) Schedule 40 fire retardant polypropylene (FRPP) pipe for use in closed (process or supply) or vented (drain, waste or vent) piping systems.
 - E. Nom 4 in. (102 mm) diam (or smaller) Rigid Nonmetallic Conduit formed of PVC.
 - F. Nom 1 in. (25 mm) diam (smaller) Electrical Nonmetallic Tubing formed of PVC.
 - G. Nom 6 in. (152 mm) diam (or smaller) SDR13.5 chlorinated polyvinyl chloride (CPVC) pipe for use in closed (process or supply) piping systems.

See Rigid Nonmetallic Conduit (DZKT) and Electrical Nonmetallic Tubing (FKHU) categories in UL Electrical Construction Materials Directory for names of manufacturers.

3. Firestop System - Installed symmetrically on both sides of wall assembly. The hourly F and T Ratings for the firestop system are dependent upon the type and size of nonmetallic pipe or conduit, the piping system type (closed systems such as process or supply piping or vented systems such as drain, waste or vent piping) and the hourly fire rating of the wall assembly in which it is installed, as shown in the following table:

| Pipe Conduit Type | Nom. Pipe Diam. in. (mm) | Annular Space in. (mm) | Piping System (a) | Wall Fire Rating Hr | F Rating Hr | T Rating Hr |
|-------------------|--------------------------|------------------------|-------------------|---------------------|-------------|-------------|
| FRPP | 1/2 (13) to 2 (51) | 0 (0) - 3/16 (5) | V | 2 | 1 1/2 | 1 1/2 |
| FRPP, PB | 1/2 (13) to 2 (51) | 0 (0) - 3/16 (5) | C, V | 2 | 2 | 2 |
| ABS | 1/2 (13) to 4 (102) | 0 (0) - 3/16 (5) | C, V | 1 | 1 | 3/4 |
| ABS | 1/2 (13) to 4 (102) | 0 (0) - 3/16 (5) | C, V | 2 | 1 1/2 | 1 1/2 |
| PVC | 1/2 (13) to 4 (102) | 0 (0) - 3/16 (5) | C, V | 1 | 1 | 1 |
| PVC | 1/2 (13) to 4 (102) | 0 (0) - 3/16 (5) | C, V | 2 | 2 | 2 |
| FRPP + | 2 1/2 (64) to 4 (102) | 0 (0) - 3/16 (5) | C, V | 2 | 1 1/2 | 1 1/2 |
| PVC + | 5 (127) to 6 (152) | 0 (0) - 3/16 (5) | C, V | 2 | 1 1/2 | 1 1/2 |

*Pipe covering material wrap required on pipe on both sides of wall.

(a) C = closed systems, V = vented systems.

System No. C-AJ-1175
F Rating - 2 Hr
T Rating - 0 Hr

FIRESTOP CONFIGURATION - A

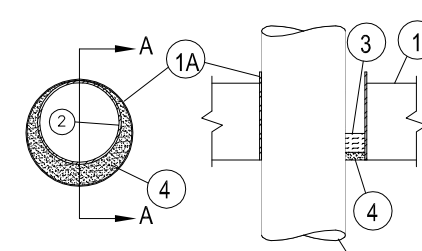

SECTION A-A

FIRESTOP CONFIGURATION - B

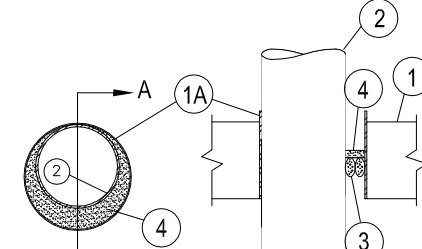

SECTION A-A

1. Floor or Wall Assembly - Min 2-1/2 in. thick lightweight or normal weight (100-150 pcf) concrete. When configuration A is used, on configuration B is used in conjunction with the steel sleeve (Item 1A), floor may be constructed of any min 6 in. thick UL Classified hollow core Precast Concrete Units*. Wall may also be constructed of any UL Classified Concrete Blocks*. Max diam of circular through opening is 10 in.

See Concrete Blocks (CAZT) and Precast Concrete Units (CFTV) categories in the Fire Resistance Directory for names of manufacturers.

1A. Steel Sleeve (Optional) - No. 10 in. diam (or smaller) Schedule 10 (or heavier) steel pipe sleeve cast into concrete floor or wall. Sleeve to be flush with or project max 2 in. from top surface of floor or from both surfaces of wall.

2. Through Penetrants - One metallic pipe, conduit or tubing to be installed either concentrically or eccentrically within the firestop system. Max annular space between pipe, conduit or tubing and edge of through opening is to exceed 1-3/8 in. Min annular space between pipe or conduit and edge of through opening is zero in. (point contact). Pipe, conduit or tubing to be rigidly supported on both sides of floor or wall assembly. The following types and sizes of metallic pipes, conduits or tubing may be used:

- A. Steel Pipe - Nom 8 in. diam (or smaller) Schedule 10 (or heavier) steel pipe.
- B. Conduit - Nom 6 in. diam (or smaller) rigid steel conduit.
- C. Conduit - Nom 4 in. diam (or smaller) steel electrical metallic tubing.
- D. Iron Pipe - Nom 4 in. diam (or smaller) cast or ductile iron pipe.
- E. Copper Tubing - Nom 6 in. diam (or smaller) Type L (or heavier) copper tube.
- F. Copper Pipe - Nom 6 in. diam (or smaller) Regular (or heavier) copper pipe.

FIRESTOP CONFIGURATION A

3. Packing Material - Min 1 in. thickness of tightly-packed mineral wool batt material used as a permanent form. Packing material to be recessed from top or bottom surface of floor or from either surface of solid concrete wall as required to accommodate the required thickness of caulk fill material (Item 4). When wall is constructed of concrete block, packing material is to be installed on both sides of wall assembly. When precast hollow core floor is used, packing material must be installed on bottom surface of floor.

4. Fill/Void or Cavity Materials* - Caulk or Sealant - Applied to fill the annular space to a min depth of 1/2 in. flush with the top or bottom surface of the floor or either surface of the solid concrete wall. A min 1/4 in. diam bead of caulk shall be applied to the floor or wall surface where the pipe, conduit or EMT is installed in point contact with the edge of the through opening. When wall is constructed of concrete block, caulk to be installed symmetrically on both sides of wall assembly. When precast hollow core floor is used, caulk fill material must be installed on bottom surface of floor.

3M COMPANY - CP 25WB+ caulk or FB-3000 WT sealant.
(The W Rating applies only when FB-3000 WT is used flush with the top surface of floor.)

FIRESTOP CONFIGURATION B

3. Packing Material - Polyethylene backed rod or nom 1 in. thickness of tightly-packed mineral wool batt insulation firmly packed into opening as a permanent form. Packing material to be recessed min 1/2 in. from top surface of floor or from both surfaces of wall as required to accommodate the required thickness of caulk fill material (Item 4).

4. Fill/Void or Cavity Materials* - Caulk or Sealant - Applied to fill the annular space to a min depth of 1/2 in. flush with the top surface of the floor or both surfaces of the wall. A min 1/4 in. diam bead of caulk shall be applied to the floor or wall surface where the pipe, conduit or EMT is installed in point contact with the edge of the through opening.

3M COMPANY - CP 25WB+ caulk or FB-3000 WT sealant. (The W Rating applies only when FB-3000 WT is used.)

*Bearing the UL Classification Mark

System No. F-A-2002
(Formerly System No 254)
F Rating - 1, 1 1/2, 2 Hr (See Item 3)
T Rating - 1, 1 1/2, 2 Hr (See Item 3)

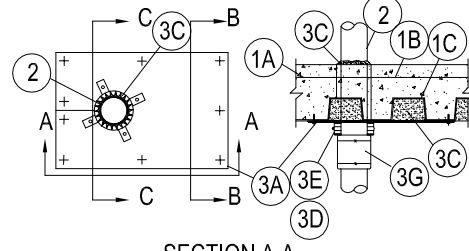

SECTION A-A

SECTION B-B

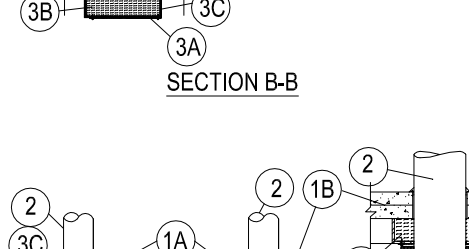

SECTION C-C

CONFIG. B

SECTION C-C

CONFIG. C

1. Floor-Ceiling Assembly - The fire-rated unprotected steel deck Floor-Ceiling assembly shall be constructed of the materials and in the manner specified in the individual D900 Series Designs in the UL Fire Resistance Directory and as summarized below:

- A. Normal Weight or Lightweight Concrete - Normal weight concrete with carbonate or siliceous aggregate, 145 to 155 pcf or 2300-2500 kg/m3 unit weight, min 3000 psi (210 kg/cm2) compressive strength. Lightweight concrete with expanded shale, clay or slate aggregate, 105 to 115 pcf or 1700-1850 kg/m3 unit weight, min 3000 psi compressive strength.
- B. Welded Wire Fabric - 6x6-W1.4xW1.4.
- C. Steel Floor and Form Units* - Composite or noncomposite 1-1/2, 2, 3 in. (38, 51, or 76 mm) deep fluted galv units as specified in the individual Floor-Ceiling design.

Max diam of opening core-drilled through floor assembly is 9 in. (229 mm).

2. Nonmetallic Pipe - Nom 4 in. (102 mm) diam (or smaller) Schedule 40 flame retardant polypropylene (FRPP) pipe or nom 8 in. (203 mm) diam (or smaller) Schedule 40 solid core polyvinyl chloride (PVC) pipe or nom 8 in. (203 mm) diam (or smaller) Schedule 40 chlorinated polyvinyl chloride (CPVC) pipe for use in closed (process or supply) or vented (drain, waste or vent) piping systems. Diam of circular opening core-drilled through Floor-Ceiling assembly to be no greater than 12 in. (13 mm) larger than outside diam of pipe. Pipe to be centered in through opening and rigidly supported on both sides of floor assembly.

3. Firestop System - The hourly F and T Ratings for the firestop system are dependent upon the type and thickness of the concrete topping over the fluted steel floor units, the type and size of the nonmetallic pipe and the firestop configuration, as tabulated below:

| Concrete Type (a) | Min Concrete Topping Thkns. in. (mm) | Pipe Type | Nom Pipe Diam. in. (mm) | Firestop Config (b) | F Rating Hr | T Rating Hr |
|-------------------|--------------------------------------|-----------------|-------------------------|---------------------|-------------|-------------|
| NW | 2-1/2 (63) | CPVC, PVC | 1/2 - 4 (13-102) | A | 1 | 0 |
| NW | 3-1/2 (89) | CPVC, FRPP, PVC | 1/2 - 4 (13-102) | B | 1 | 1 |
| NW | 3-1/2 (89) | CPVC, PVC | 6, 8 (152, 203) | C | 1 | 1 |
| NW | 4 (102) | CPVC, PVC | 1/2 to 4 (13-102) | A | 1-1/2 | 0 |
| NW | 4 (102) | CPVC, FRPP, PVC | 1/2 to 4 (13-102) | B | 1-1/2 | 1-1/2 |
| NW | 4 (102) | CPVC, PVC | 6, 8 (152, 203) | C | 1-1/2 | 1-1/2 |
| NW | 4-1/2 (114) | CPVC, PVC | 1/2 to 4 (13-102) | A | 2 | 0 |
| NW | 4-1/2 (114) | CPVC, FRPP, PVC | 1/2 to 4 (13-102) | B | 2 | 2 |
| NW | 4-1/2 (114) | CPVC, PVC | 6, 8 (152, 203) | C | 2 | 2 |
| LW | 3-1/4 (82.6) | CPVC, PVC | 1/2 to 4 (13-102) | A | 2 | 0 |
| LW | 3-1/4 (82.6) | CPVC, FRPP, PVC | 1/2 to 4 (13-102) | B | 2 | 2 |
| LW | 3-1/4 (82.6) | CPVC, PVC | 6, 8 (13-102) | C | 2 | 2 |

(a) NW denotes normal weight concrete, LW denotes lightweight concrete.

(b) A, B and C indicate firestop configuration, as described in the following:

Firestop Configuration A

A. Fill/Void or Cavity Materials* - Intumescent Sheet - Rigid aluminum foil-faced sheet with galv steel sheet backer. Width of sheet to be min 6 in. (152 mm) greater than outside diam of nonmetallic pipe. Length of sheet (transverse to steel floor unit direction) to extend to steel floor unit valley beyond each side of core-drilled hole with a min lap of 1-1/2 in. (38 mm) on the steel floor unit valley at each end. Circular cutout in sheet to tightly follow circumference of nonmetallic pipe with side edges of sheet at least 3 in. (76 mm) from circular cutout on all sides. Slit made in sheet to permit installation around the nonmetallic pipe to be located at end of sheet beneath steel floor unit valley nearest to the circular cutout. Sheet to be installed with the galv steel sheet backer exposed (aluminum foil face against steel floor unit). Sheet secured to valleys of steel floor unit using min 3/16 in. diam by 1-1/2 in. (5 mm by 38 mm) long steel expansion bolts, or equivalent, in conjunction with min 1-1/4 in. (32 mm) diam steel fender washers. Fasteners to be located approx 1 in. (25 mm) from edges of sheet at each corner, at each sheet/valley intersection and at both sides of slit made to permit installation around nonmetallic pipe. Spacing of fasteners at ends of sheet not to exceed 6 in. (152 mm) OC.

B. Packing Material - Mineral wool batt insulation having a min density of 6 pcf (96 kg/m3), firmly packed into flutes of steel floor units above intumescent sheet (Item 3A) to completely fill cavities.

C. Fill/Void or Cavity Materials* - Putty - Moldable putty material supplied in nom 1/8 in. (3.2 mm) thick sheets. Min 1/8 in. (3.2 mm) thick sheet of putty material applied over packing material (Item B) at edges of intumescent sheet to completely cover packing material in steel floor unit flutes. Additional putty material kneaded by hand and packed into annular space between nonmetallic pipe and edge of core-drilled hole at top surface of concrete floor.

3M COMPANY - MP+ Sbk
D. Fill/Void or Cavity Materials* - Wrap Strip - Nom 1/4 in. (6 mm) thick intumescent elastomeric material faced on one side with aluminum foil, supplied in 2 in. (51 mm) wide by 24 in. (610 mm) long strips. Nom 2 in. (51 mm) wide strips tightly wrapped around nonmetallic pipe (foil side exposed) with the top edges butted against the underside of the intumescent sheet. Sufficient layers of wrap strip shall be installed to lap a min of 3/16 in. (5 mm) on the intumescent sheet surface around the entire circumference of the nonmetallic pipe. For nom 1/2 in. to nom 2 in. (13 mm to nom 51 mm) diam pipes, a min of one layer of wrap strip is required. For nom 2-1/2 in. and nom 3 in. (64 mm to nom 76 mm) diam pipes, a min of two layers of wrap strip are required. For nom 3-1/2 in. and nom 4 in. (89 mm to nom 102 mm) diam pipes, a min of three layers of wrap strip are required. Each layer of wrap strip to be installed with butted seam, with butted seams in successive layers staggered. Wrap strip layers temporarily held in position using aluminum foil tape, filament tape, steel wire tie, or equivalent.

3M COMPANY - FS-195
E. Steel Collar - Nom 2 in. (51 mm) deep collar with 1-1/4 in. (32 mm) wide by 2 in. (51 mm) long anchor tabs and min 3/4 in. (19 mm) long tabs to retain wrap strip layers. Coils of precut 0.016 in. (0.41 mm) thick (30 gauge) galv sheet steel available from wrap strip manufacturer. As an alternate, collar may be field-fabricated from min 0.016 in. (0.41 mm) thick (30 gauge) galv sheet in accordance with instruction sheet supplied by wrap strip manufacturer. Steel collar, with anchor tabs bent outward 90 deg, wrapped tightly around wrap strip layers with min 1 in. (25 mm) overlap at seam. With steel collar anchor tabs pressed tightly against underside of intumescent sheet, compress collar around wrap strip layers using a min 1/2 in. (13 mm) wide by 0.028 in. (0.71 mm) thick stainless steel band clamp with worm drive tightening mechanism at the collar midheight. Beneath valleys of steel floor units, anchor tabs of collar secured to intumescent sheet with min 3/16 in. (5 mm) diam by 1-1/2 in. (38 mm) long steel anchor bolts, or equivalent, in conjunction with min 1-1/4 in. (32 mm) diam steel fender washers. Away from valleys, anchor tabs of collar secured to intumescent sheet with No. 10 sheet metal screws in conjunction with min 1-1/4 in. (32 mm) diam steel fender washers. Three anchor bolts, symmetrically located, required for nom 2 and 3 in. (51 mm and 76 mm) diam pipes. Four anchor bolts, symmetrically located, required for nom 4 in. (102 mm) diam pipes. As a final step, bend retainer tabs 90 deg toward pipe to lock wrap strip layers in position.

F. Fill/Void or Cavity Materials* - Caulk or Sealant (Not Shown) - Generous bead of caulk to be applied to outer perimeter of wrap strip at its interface with intumescent sheet, to perimeter of pipe at its egress from the wrap strip layers and to perimeter of sheet at its interface with valleys of steel floor unit.

3M COMPANY - CP 25WB+ caulk or FB-3000 WT sealant. (Note: CP 25WB+ not suitable for use with CPVC pipes.)

G. Firestop Device* (Not Shown) - As an alternate to Items D, E and F for nom 1-1/2, 2, 3 or 4 in. (38, 51, 76 or 102 mm) diam nonmetallic pipes, a firestop device consisting of a sheet-steel split collar lined with intumescent material and provided with steel clips for attachment may be used. Firestop device to be installed on underside of intumescent sheet (Item A) in accordance with the accompanying installation instructions.

3M COMPANY - PPD 150, PPD 200, PPD 300, PPD 400

Firestop Configuration B

A. Fill/Void or Cavity Materials* - Intumescent Sheet - Same as Firestop Configuration A.

3M COMPANY - CS-195+

B. Packing Material - Same as Firestop Configuration A.

C. Fill/Void or Cavity Materials* - Putty - Same as Firestop Configuration A.

3M COMPANY - MP+ Sbk

D. Fill/Void or Cavity Materials* - Wrap Strip - Same as Firestop Configuration A.

3M COMPANY - FS-195+

E. Steel Collar - Same as Firestop Configuration A.

F. Fill/Void or Cavity Materials* - Caulk or Sealant - Same as Firestop Configuration A.

3M COMPANY - CP 25WB+ caulk or FB-3000 WT sealant.

(Note: CP 25WB+ not suitable for use with CPVC pipes.)

G. Pipe Covering* - Nom 1 in. (25 mm) thick hollow cylindrical heavy (min 3.5 pcf or 56 kg/m3) density glass fiber units jacketed on the outside with an all service jacket. Nom 6 in. (152 mm) length of pipe covering installed around nonmetallic pipe, with top edge abutting steel collar, and secured to pipe with No. 16 gauge steel tie wires located 1 in. (25 mm) from each edge.

H. Firestop Device* (Not Shown) - As an alternate to Items D, E and F for nom 1-1/2, 2, 3 or 4 in. (38, 51, 76 or 102 mm) diam nonmetallic pipes, a firestop device consisting of a sheet-steel split collar lined with intumescent material and provided with steel clips for attachment may be used. Firestop device to be installed on underside of intumescent sheet (Item A) in accordance with the accompanying installation instructions.

3M COMPANY - PPD 150, PPD 200, PPD 300, PPD 400

Firestop Configuration C

A. Fill/Void or Cavity Materials* - Intumescent Sheet - Same as Firestop Configuration A.

3M COMPANY - CS-195+

B. Packing Material - Same as Firestop Configuration A.

C. Fill/Void or Cavity Materials* - Putty - Same as Firestop Configuration A.

3M COMPANY - MP+ Sbk

D. Fill/Void or Cavity Materials* - Wrap Strip - Nom 1/4 in. (6 mm) thick intumescent elastomeric material faced on one side with aluminum foil, supplied in 4 in. (102 mm) wide by 24 in. (610 mm) long strips. Nom 4 in. (102 mm) wide strips tightly wrapped around nonmetallic pipe with the top edges butted against the intumescent sheet. For nom 6 in. (152 mm) diam pipes, three layers of wrap strip are required. For nom 8 in. (203 mm) diam pipes, four layers of wrap strip are required. Each layer of wrap strip to be installed with butted seam with butted seams in successive layers staggered. Wrap strips temporarily held in position using aluminum foil tape, filament tape, steel wire tie, or equivalent.

3M COMPANY - FS-195+

E. Steel Collar - Nom 4 in. (114 mm) deep collar with 1-1/4 in. (32 mm) wide by 2 in. (51 mm) long anchor tabs to retain wrap strip layers. Coils of precut 0.016 in. (0.41 mm) thick (No. 30 gauge) galv sheet steel available from wrap strip manufacturer. As an alternate, collar may be field-fabricated from min 0.016 in. (0.41 mm) thick (No. 30 gauge) galv sheet steel in accordance with instruction sheet supplied by wrap strip manufacturer. Steel collar, with anchor tabs bent outward 90 deg, wrapped tightly around wrap strip layers using two min 1/2 in. (13 mm) wide by 0.028 in. (0.71 mm) thick stainless steel band clamps with worm gear tightening mechanisms, with the clamps located near the quarter points of the wrap strips. Beneath valleys of steel floor units, anchor tabs of collar secured to intumescent sheet with min 3/16 in. (5 mm) diam by 1-1/2 in. (38 mm) long steel anchor bolts, or equivalent, in conjunction with min