

1 2 3 4 5 6

A

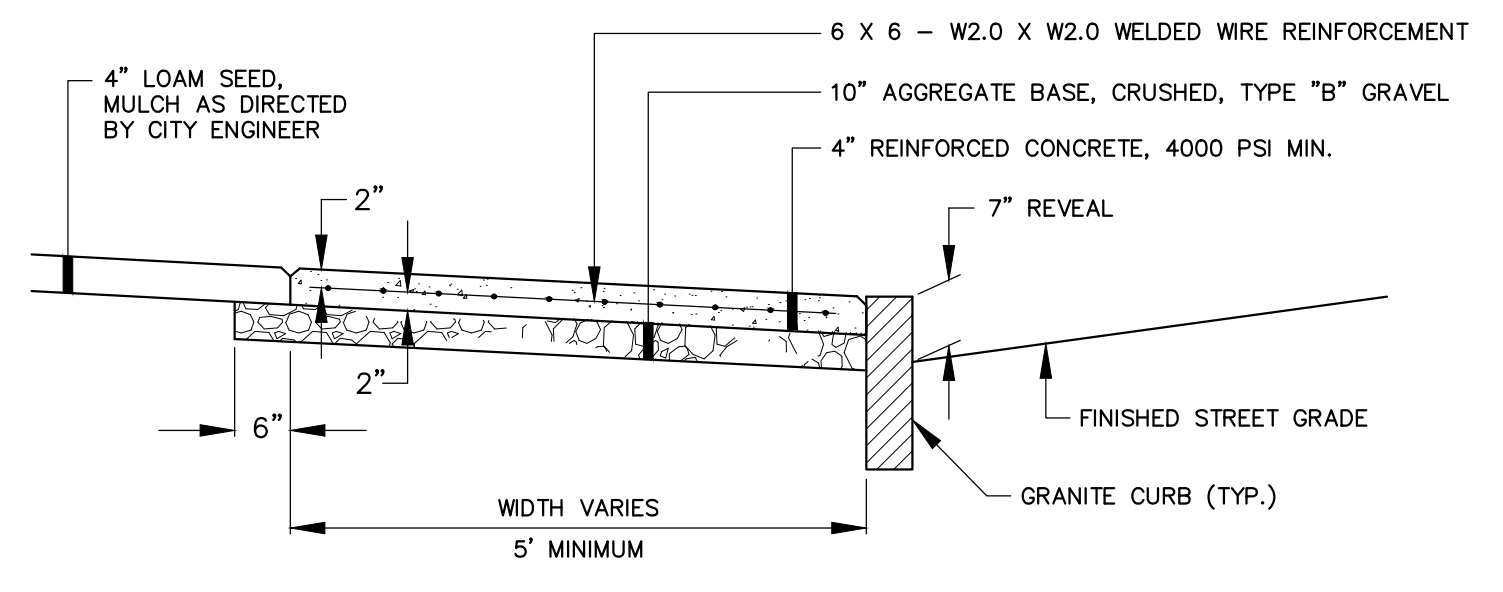

REINFORCED CONCRETE SIDEWALK
N.T.S.

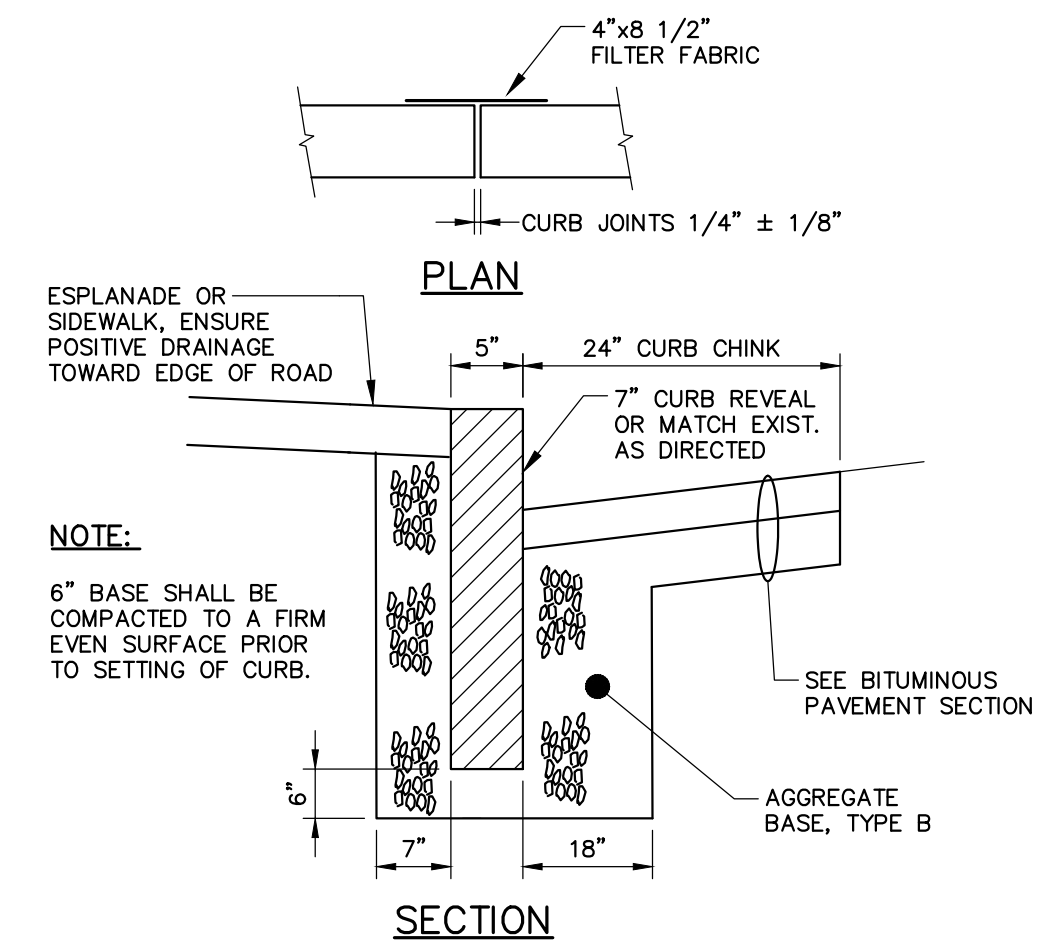
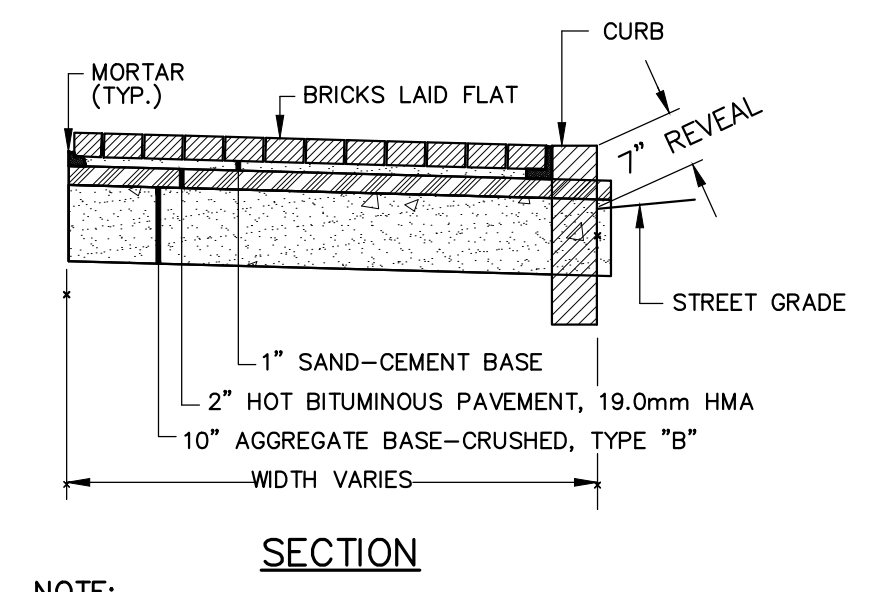

BRICK SIDEWALK DETAIL
N.T.S.

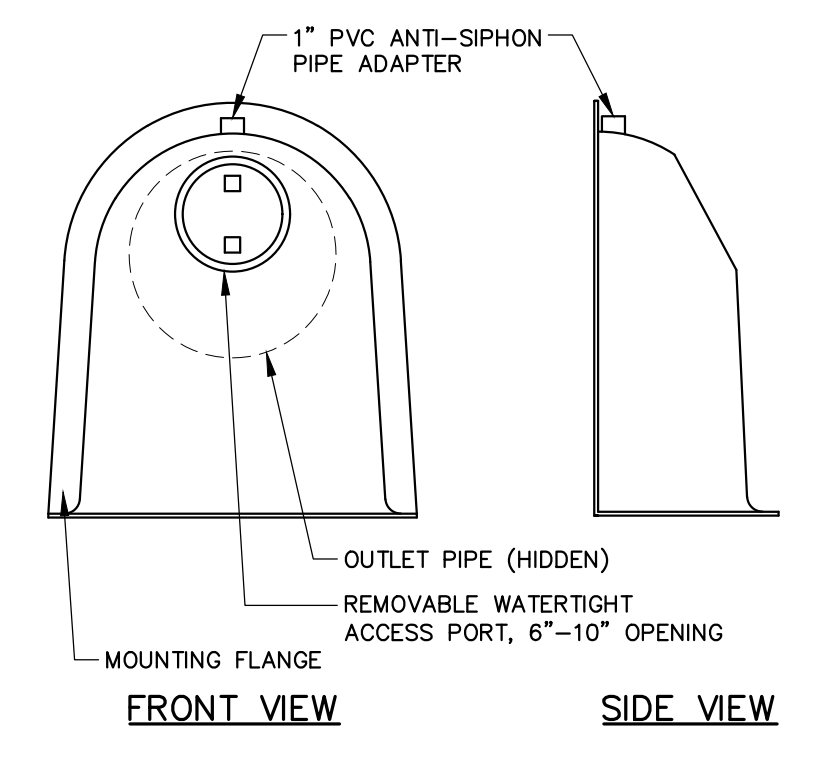

- NOTES:**
- ALL HOODS AND TRAPS FOR CATCH BASINS AND WATER QUALITY STRUCTURES SHALL BE AS MANUFACTURED BY BEST MANAGEMENT PRODUCTS, INC. OR PRE-APPROVED EQUAL.
 - ALL HOODS SHALL BE CONSTRUCTED OF A GLASS REINFORCED RESIN COMPOSITE WITH ISO GEL COAT EXTERIOR FINISH WITH A MINIMUM 0.125" LAMINATE THICKNESS.
 - ALL HOODS SHALL BE EQUIPPED WITH A WATERTIGHT ACCESS PORT, A MOUNTING FLANGE, AND AN ANTI-SIPHON VENT PIPE AND ELBOW.
 - THE SIZE AND POSITION OF THE HOOD SHALL BE DETERMINED BY OUTLET PIPE SIZE AS PER MANUFACTURER'S RECOMMENDATION (SNOUT SIZE ALWAYS LARGER THAN PIPE SIZE).
 - THE BOTTOM OF THE HOOD SHALL EXTEND DOWNWARD A MINIMUM DISTANCE EQUAL TO 1/2 THE OUTLET PIPE DIAMETER WITH A MINIMUM DISTANCE OF 6" FOR PIPES <12" I.D.
 - THE ANTI-SIPHON VENT SHALL EXTEND ABOVE HOOD BY MINIMUM OF 3" AND A MAXIMUM OF 12" ACCORDING TO STRUCTURE CONFIGURATION.
 - THE SURFACE OF THE STRUCTURE WHERE THE HOOD IS MOUNTED SHALL BE FINISHED SMOOTH AND FREE OF LOOSE MATERIAL AND PIPE SHALL BE FINISHED FLUSH TO WALL.
 - THE HOOD SHALL BE SECURELY ATTACHED TO STRUCTURE WALL WITH 3/8" STAINLESS STEEL BOLTS AND OIL-RESISTANT GASKET AS SUPPLIED BY MANUFACTURER.
 - INSTALLATION INSTRUCTIONS SHALL BE FURNISHED WITH MANUFACTURER SUPPLIED INSTALLATION KIT. INSTALLATION KIT SHALL INCLUDE: INSTALLATION INSTRUCTIONS, PVC ANTI-SIPHON VENT PIPE AND ADAPTER, OIL-RESISTANT CRUSHED CELL FOAM GASKET WITH PSA BACKING, 3/8" STAINLESS STEEL BOLTS, AND ANCHOR SHIELDS.

SNOUT OIL-WATER-DEBRIS SEPARATOR DETAIL
N.T.S.

B

CURB TYPE 1 ON CURVES

TYPE	RADIUS OF CURVE	LENGTH	STONE IS CUT OR CAST
1	0' TO 60' INCL.	4' MIN.	ARC TO FIT CURVE
	OVER 60' TO 160'	4' TO 6'	STRAIGHT PIECES

TYPICAL NEW AND RESET CURB INSTALLATION
N.T.S.
NOTE: AGGREGATE TYPES PER MDOT SECTION 304.02

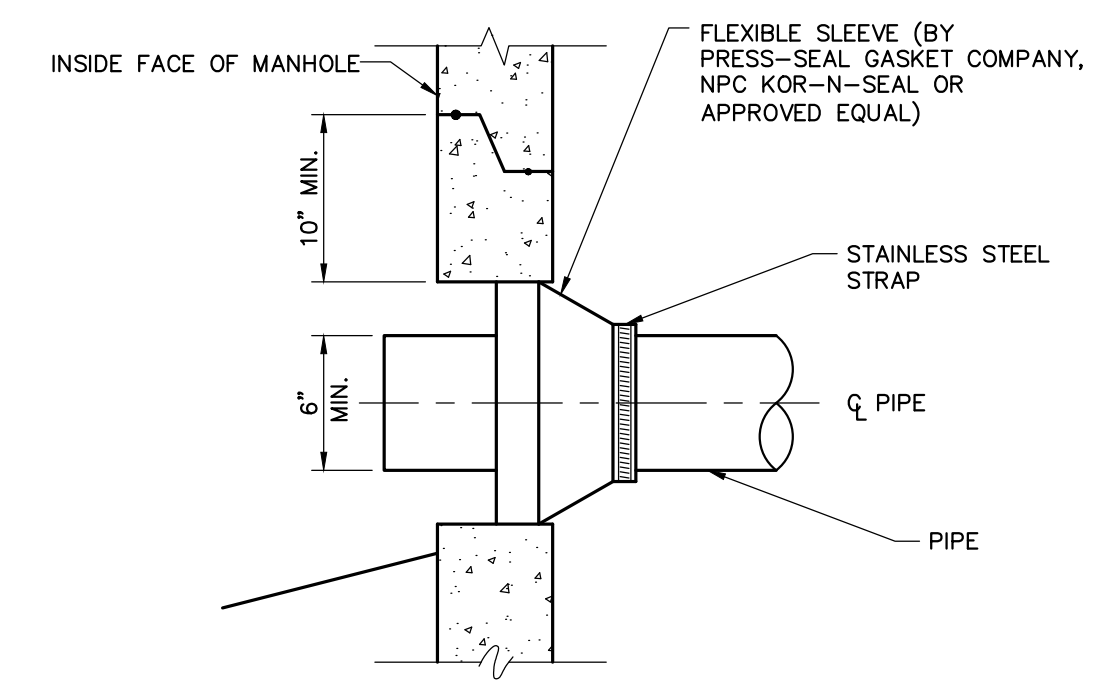

NEW PIPE TO NEW STRUCTURE CONNECTION DETAIL
N.T.S.

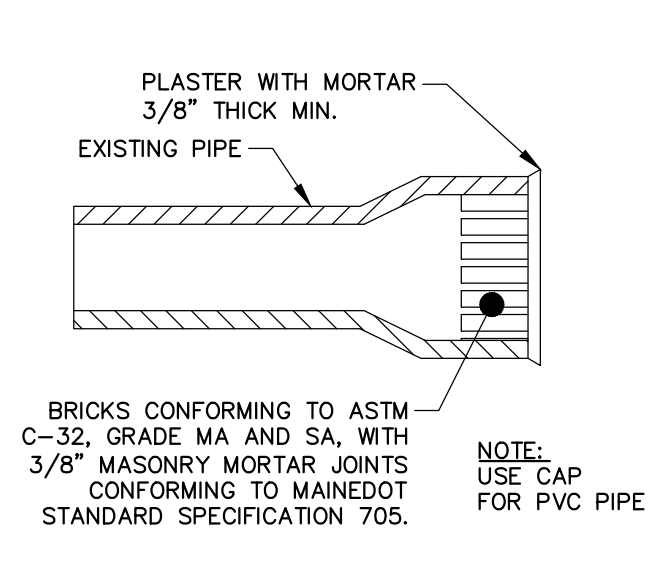

MASONRY PLUG DETAIL
N.T.S.

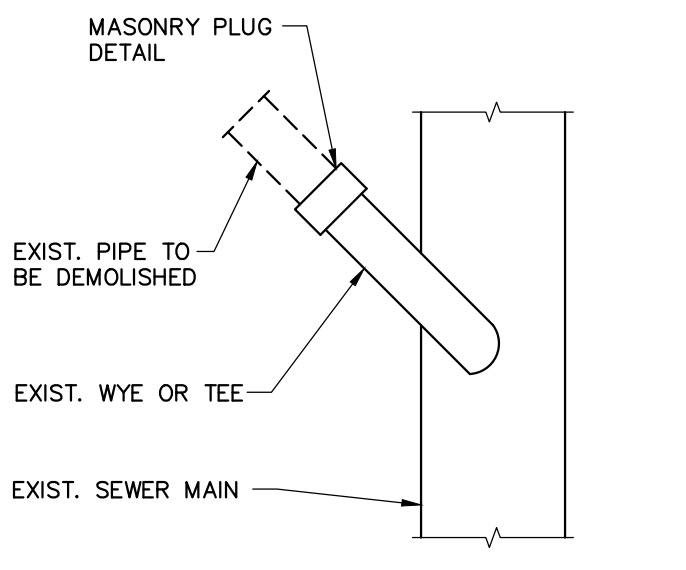

MASONRY PLUG @ MAIN
N.T.S.

C

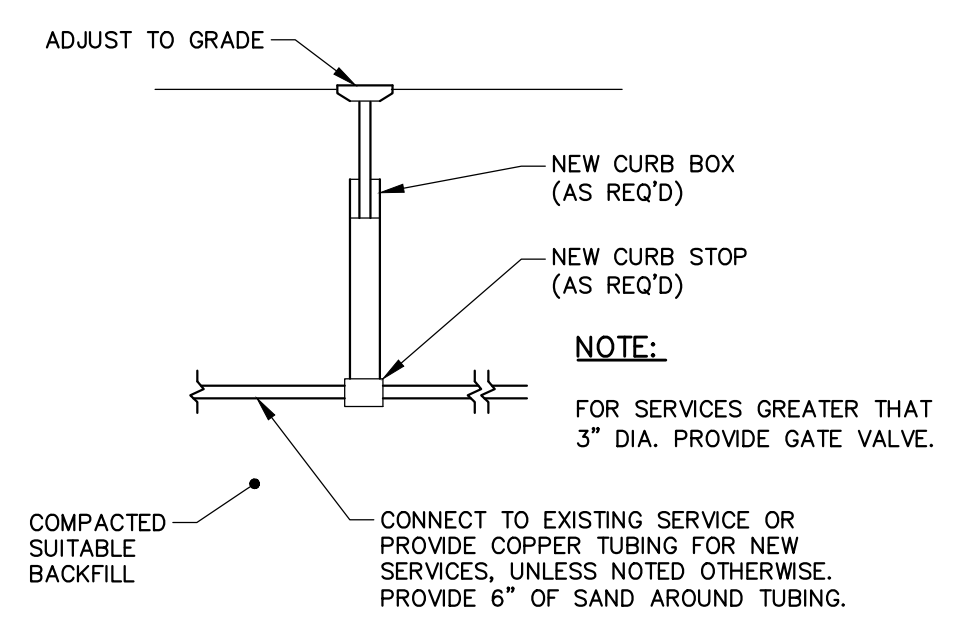

TYPICAL WATER SERVICE DETAIL
N.T.S.

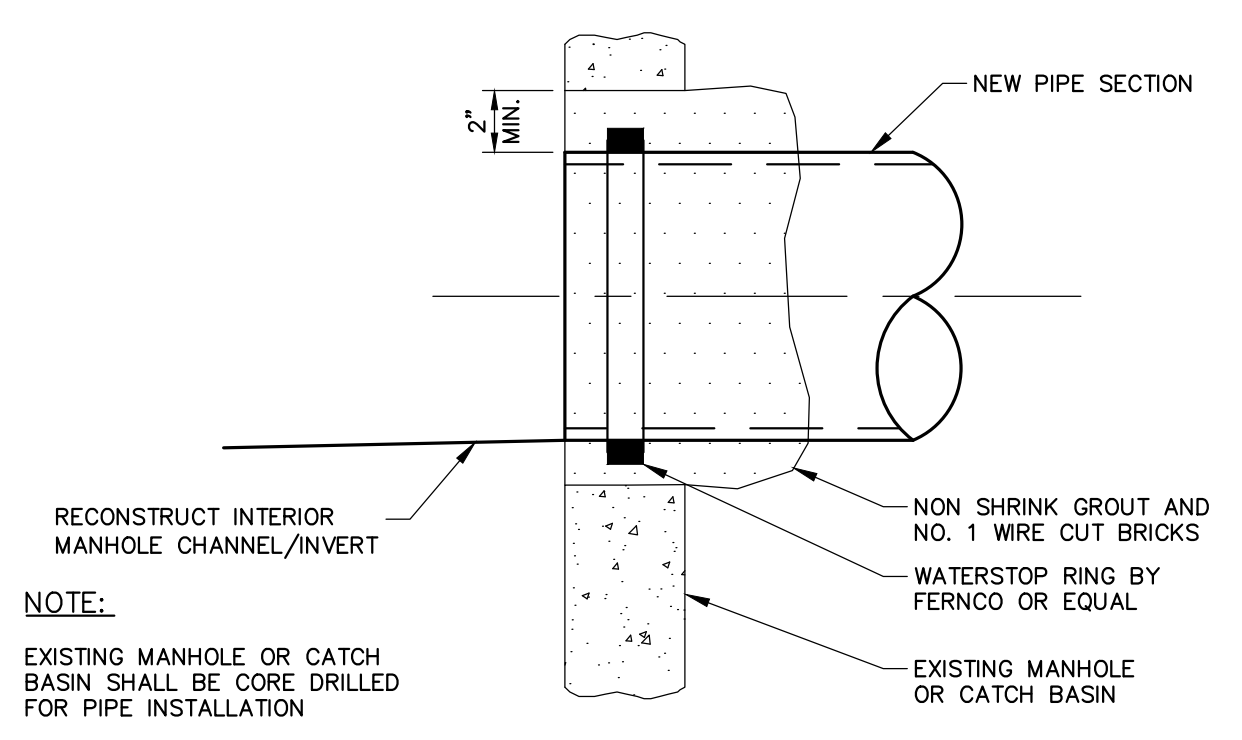

NEW PIPE TO EXISTING STRUCTURE
N.T.S.

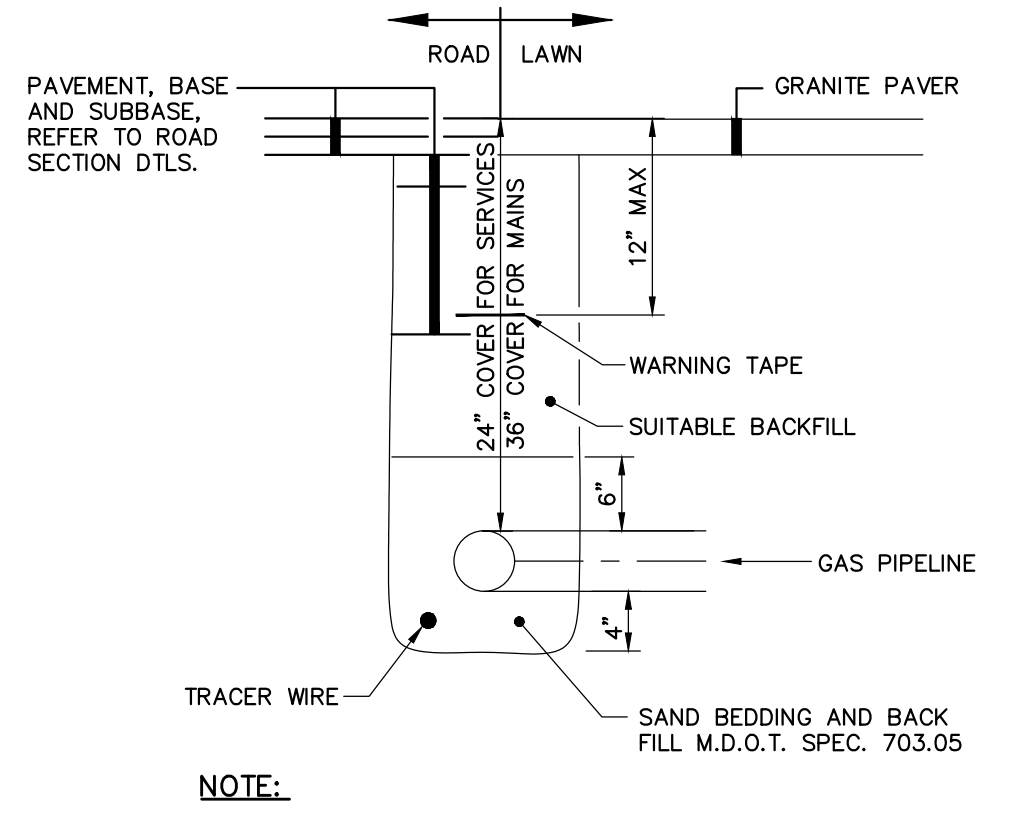

NATURAL GAS PIPE
N.T.S.

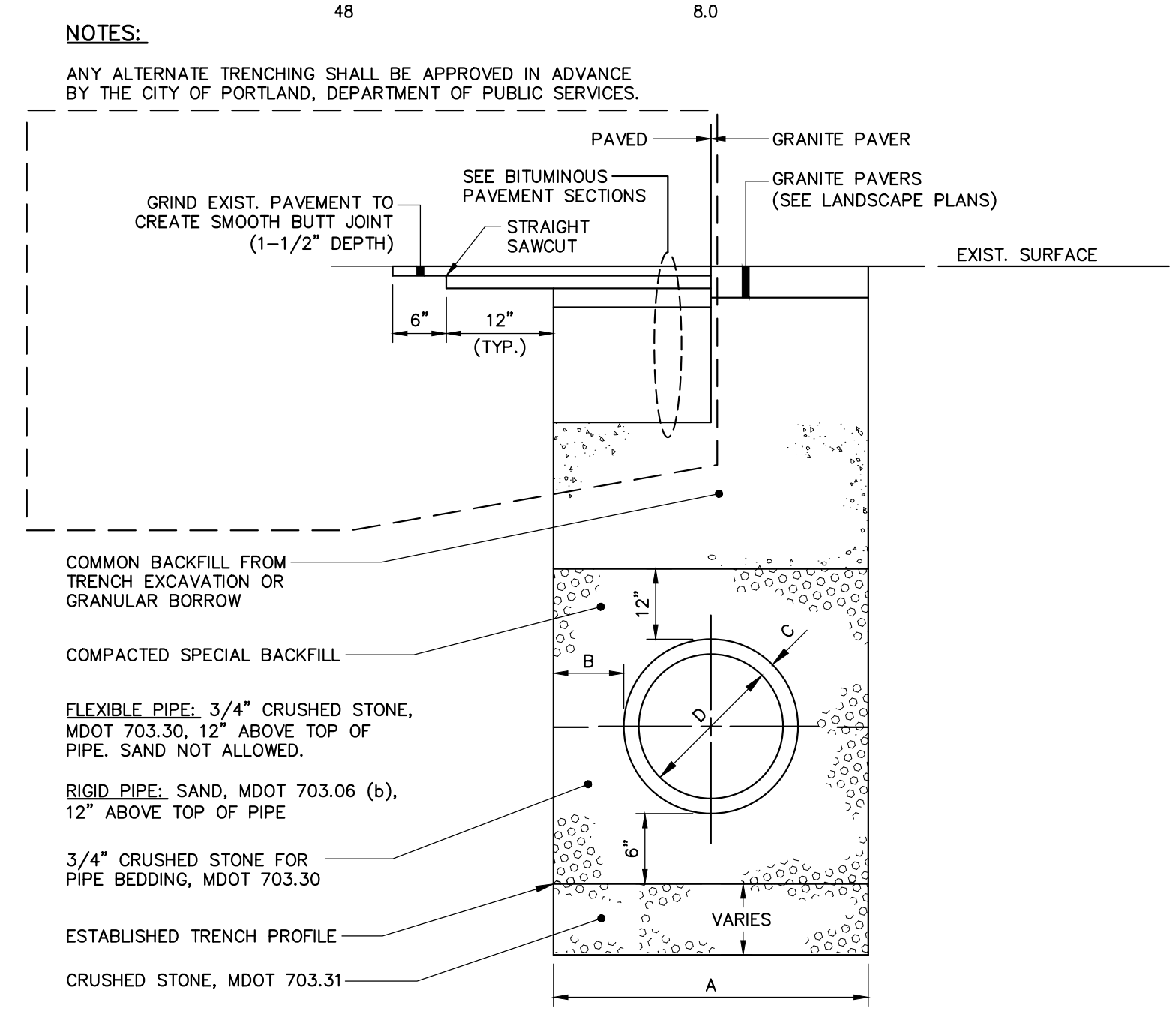

- NOTES:**
- IN PAVED AREAS, DEPTHS OF GRAVEL AND HOT MIX ASPHALT PAVEMENT SHALL MATCH THE GREATER OF EXISTING CONDITIONS OR THE REQUIREMENTS FOR THE CORRESPONDING STREET CLASSIFICATION.
 - DIMENSION "B" SHALL BE SUFFICIENT TO ALLOW CRUSHED STONE BEDDING TO BE PLACED AND COMPACTED UNDER THE HAUNCHES OF THE PIPE, BUT IN ALL CASES "B" SHALL BE AT LEAST 9".
 - DIMENSION "A" SHALL BE BASED ON PIPE DIAMETER, AS SET FORTH IN THE FOLLOWING TABLE.
- | PIPE DIAMETER, "D" (INCHES) | MAX. TRENCH WIDTH, "A" (FEET) |
|-----------------------------|-------------------------------|
| 6 | 4.0 |
| 8 | 4.0 |
| 10 | 4.0 |
| 12 | 4.0 |
| 15 | 4.0 |
| 18 | 5.0 |
| 21 | 5.0 |
| 24 | 5.5 |
| 27 | 6.0 |
| 30 | 6.0 |
| 36 | 7.0 |
| 42 | 8.0 |
| 48 | 8.0 |
- ANY ALTERNATE TRENCHING SHALL BE APPROVED IN ADVANCE BY THE CITY OF PORTLAND, DEPARTMENT OF PUBLIC SERVICES.

GENERAL NOTES FOR MANHOLES AND CATCH BASINS

- ALL CONCRETE SHALL BE CLASS "A" AND HAVE A MINIMUM ULTIMATE COMPRESSIVE STRENGTH OF 4000 LBS. PER SQ. INCH AT THE END OF 28 DAYS, UNLESS OTHERWISE NOTED.
- PRECAST REINFORCED CONE BARREL MANUFACTURED PER ASTM SPEC. C-478.
- ALL MANHOLES SHALL HAVE A BITUMINOUS WATERPROOFING APPLIED TO THE EXTERIOR SURFACE. IF CONSTRUCTED OF BRICK MASONRY, SURFACE SHALL BE PLASTERED WITH A SMOOTH MORTAR FINISH 3/8" THICK. AFTER THE MORTAR HAS SET, THE SURFACE SHALL BE WATERPROOFED AS REQUIRED BY SUPPLEMENTAL SPECIFICATIONS SECTION 604.
- CASTINGS SHALL CONFORM TO ASTM DESIGNATION A48-CLASS 35. ALL PARTS OF CASTINGS, EXCEPT FINISHED SURFACE, SHALL RECEIVE A COAT OF COAL TAR PITCH VARNISH OR ASPHALTUM PAINT WHICH SHALL BE SMOOTH AND TOUGH BUT NOT BRITTLE.
- MANHOLES MAY BE CONSTRUCTED OF MASONRY, PRECAST REINFORCED CONCRETE, OR CAST IN PLACE.
- CONTRACTOR SHALL SUBMIT ANTI-FLOATATION CALCULATIONS FOR ALL MANHOLE AND CATCH BASIN STRUCTURES.
- ALL PRECAST MANHOLES AND CATCH BASINS SHALL BE IDENTIFIED BY STATION, OFFSET, AND STRUCTURE ID PAINTED ON THE SIDE OF THE STRUCTURE BY THE MANUFACTURER.
- STORM AND SEWER MANHOLES SHALL HAVE SOLID COVERS WITH ONE DRILLED PICK HOLE.
- EXISTING MANHOLES, CATCH BASINS, FRAMES, AND COVERS SHALL BE SALVAGED BY THE CONTRACTOR, AND SHALL REMAIN THE PROPERTY OF THE CITY OF PORTLAND.
- WHEN THE FLOW CHANGES DIRECTION IN A MANHOLE, THE CHANNEL ALIGNMENT SHALL FOLLOW A SMOOTH RADIUS. CHANNELS SHALL BE FORMED TO ACCEPT ALL INLET PIPES.
- ON STORM AND SEWER MANHOLES, THE SHELF AND CHANNEL SHALL BE FORMED BY BRICK SET IN CEMENT MORTAR OR BY FACTORY PRE-CAST CONCRETE. SUCH PRE-CAST CONCRETE SHALL BE EPOXY COATED AND THE SHELF SHALL HAVE A PERMANENT NON-SKID SURFACE.

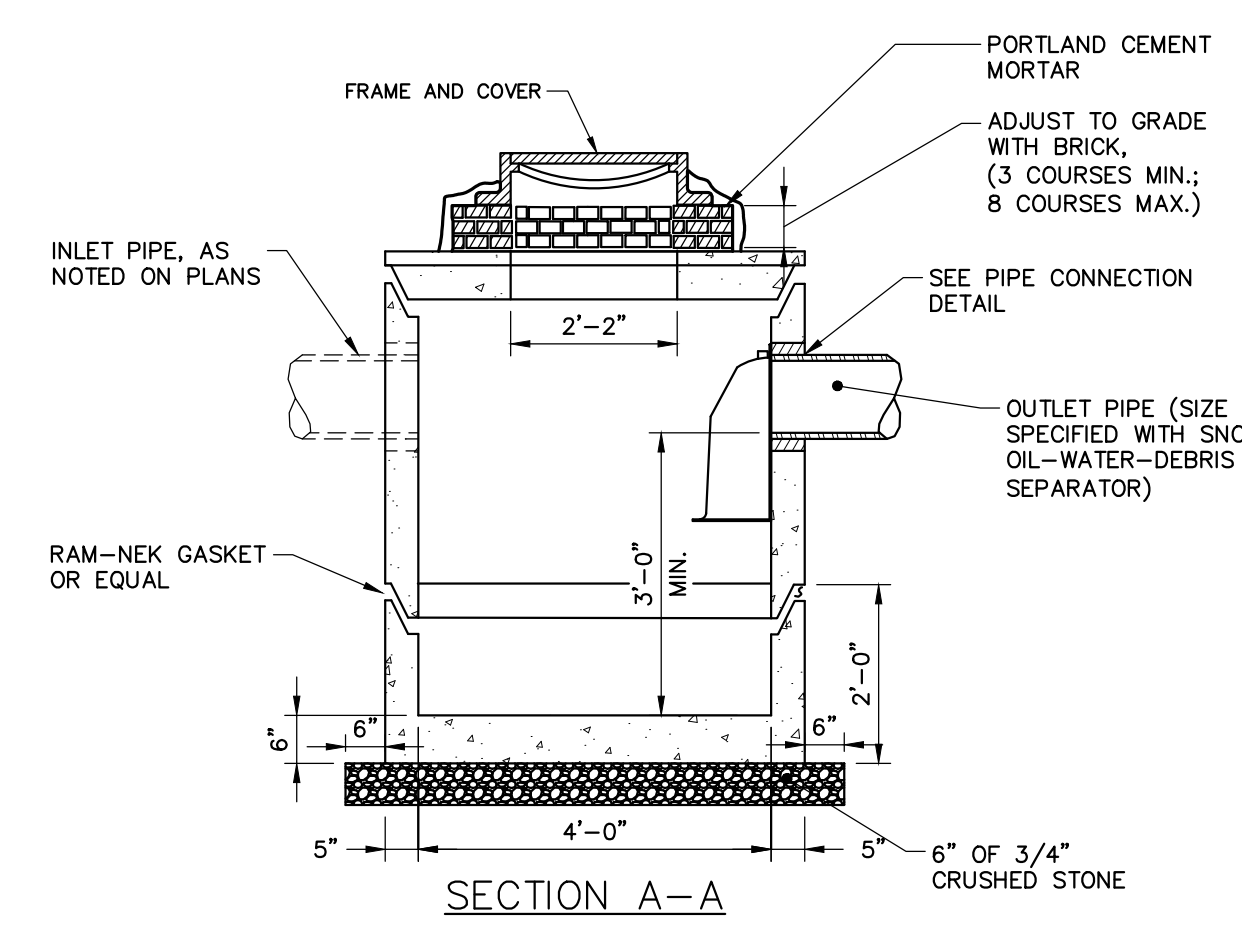

PRECAST CONCRETE CATCH BASIN
N.T.S.

BITUMINOUS PAVEMENT SECTIONS
N.T.S.

41 Hutchins Drive
Portland, Maine 04102
800.426.4262 | www.woodardcurran.com

WOODARD & CURRAN

COMMITMENT & INTEGRITY DRIVE RESULTS

THIS DOCUMENT IS THE PROPERTY OF WOODARD & CURRAN, INC. AND ITS REPRODUCTION OR MODIFICATION WITHOUT WRITTEN PERMISSION IS PROHIBITED.

LAUREN JANE SNEYD
PROJECT ENGINEER

3/21/2017

REV.	DESCRIPTION	DATE	CHECKED BY: DAS
2	REVISED WATER SERVICE	3/21/2017	
1	ADDENDUM 1	10/11/16	

DESIGNED BY: LJS
DRAWN BY: JBC

CIVIL DETAILS - 1

CANALSTUDIO

ZERO CANAL PLAZA DEVELOPMENT

JOB NO.: 229311
DATE: SEPTEMBER 19, 2016
SCALE: AS NOTED
SHEET: 8 OF 10

C-300

1 2 3 4 5 6

A

B

C

D

F:\Projects\229311 east brown cov - canal plaza fill.dwg\Civil\229311-0004.dwg, Mar 21, 2017 - 1:15pm