

THE POWER OF

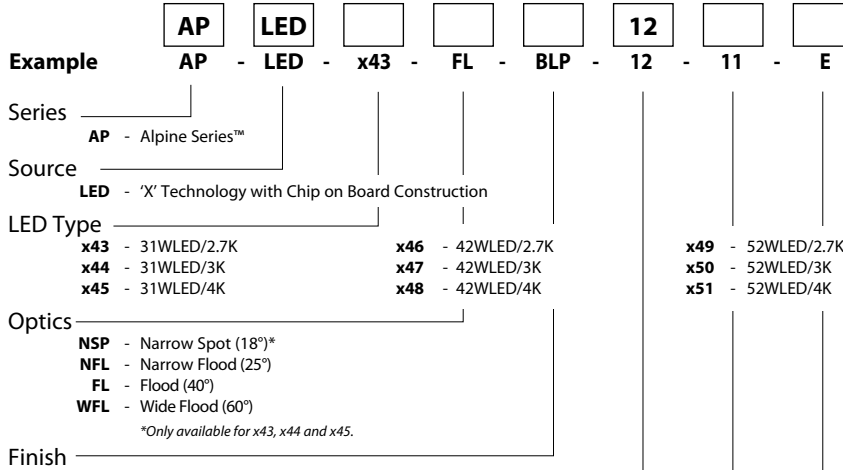

<b>PROJECT:</b>	
<b>TYPE:</b>	
<b>CATALOG NUMBER:</b>	
<b>SOURCE:</b>	
<b>NOTES:</b>	

## CATALOG NUMBER LOGIC



### Configure Driver Housing Separately Driver Housing Required

#### REMOTE DRIVER HOUSINGS:

- PM3RM** - Universal Power Module 3 Remote
- PM3DRM** - Universal Power Module 3 Dual Remote
- RM** - Remote Wall Mount
- DRM** - Dual Remote Wall Mount

#### Standard Finish

Powder Coat Color	Satin	Wrinkle
Bronze	<b>BZP</b>	<b>BZW</b>
Black	<b>BLP</b>	<b>BLW</b>
White (Gloss)	<b>WHP</b>	<b>WHW</b>
Aluminum	<b>SAP</b>	—
Verde	—	<b>VER</b>

#### Premium Finish

<b>ABP</b> Antique Brass Powder	<b>CMG</b> Cascade Mountain Granite	<b>RMG</b> Rocky Mountain Granite
<b>AMG</b> Aleutian Mountain Granite	<b>CRI</b> Cracked Ice	<b>SDS</b> Sonoran Desert Sandstone
<b>AQW</b> Antique White	<b>CRM</b> Cream	<b>SMG</b> Sierra Mountain Granite
<b>BCM</b> Black Chrome	<b>HUG</b> Hunter Green	<b>TXF</b> Textured Forest
<b>BGE</b> Beige	<b>MDS</b> Mojave Desert Sandstone	<b>WCP</b> Weathered Copper
<b>BPP</b> Brown Patina Powder	<b>NBP</b> Natural Brass Powder	<b>WIR</b> Weathered Iron
<b>CAP</b> Clear Anodized Powder	<b>OCP</b> Old Copper	<i>Also available in RAL Finishes See submittal SUB-1439-00</i>

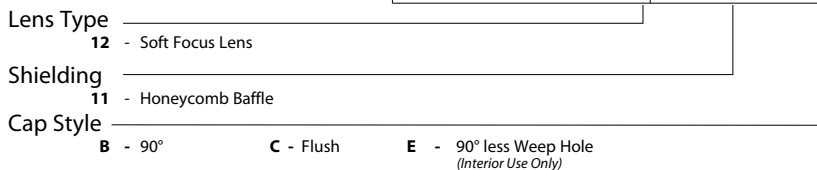

### LM79 DATA

BK No.	Lumens (Source)(Tj=85°C)	CCT (Typ.)	CRI (Ra. Typ.)	Color Consistency	Input Watts (Typ.)
x43	3150	2700K	80	±60K	31
x44	3300	3000K	80	±60K	31
x45	3450	4000K	80	±60K	31
x46	4200	2700K	80	±60K	42
x47	4350	3000K	80	±60K	42
x48	4600	4000K	80	±60K	42
x49	5700	2700K	80	±60K	52
x50	5900	3000K	80	±60K	52
x51	6200	4000K	80	±60K	52

### L70 DATA

Minimum Rated Life (hrs.) 70% of initial lumens (L70)
50,000
50,000
50,000
50,000
50,000
50,000
50,000
50,000
50,000
50,000

### OPTICAL DATA

Beam Type	Angle	x45 CBCP	x48 CBCP	x51 CBCP
Narrow Spot	18°	20780	N/A	N/A
Narrow Flood	25°	5908	17560	23105
Flood	40°	4174	5539	7311
Wide Flood	60°	2931	3725	4966

# B-K LIGHTING

40429 Brickyard Drive • Madera, CA 93636 • USA  
 559.438.5800 • FAX 559.438.5900  
 www.bklighting.com • info@bklighting.com

SUBMITTAL DATE  
02-10-15

DRAWING NUMBER  
SUB-2363-00

THIS DOCUMENT CONTAINS PROPRIETARY INFORMATION OF B-K LIGHTING, INC. AND ITS RECEIPT OR POSSESSION DOES NOT CONVEY ANY RIGHTS TO REPRODUCE, DISCLOSE ITS CONTENTS, OR TO MANUFACTURE, USE OR SELL ANYTHING IT MAY DESCRIBE. REPRODUCTION, DISCLOSURE OR USE WITHOUT SPECIFIC WRITTEN AUTHORIZATION OF B-K LIGHTING, INC. IS STRICTLY FORBIDDEN.

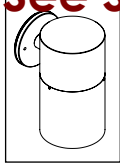

THE POWER OF



PROJECT:	
TYPE:	

## FRONT VIEW

### "B/E" CAP

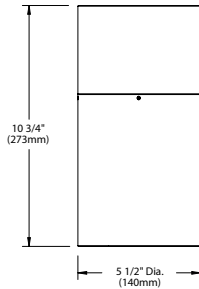

### "C" CAP

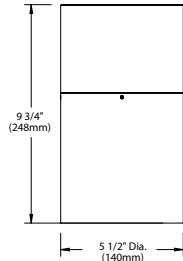

### CANOPY DETAIL

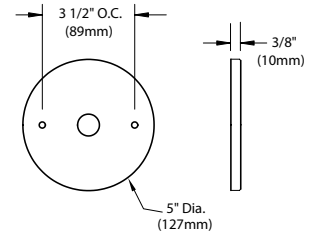

### MOUNTING RING

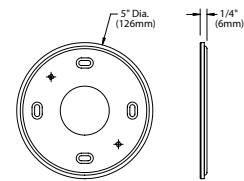

## SIDE VIEW

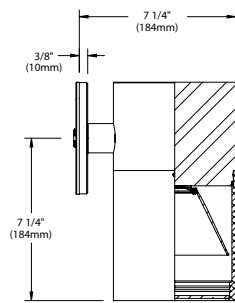
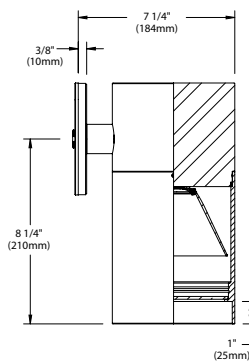

### Accessories (Configure separately)

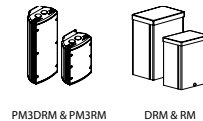

All dimensions indicated on this submittal are nominal. Contact Technical Sales if you require more stringent specifications.

## SPECIFICATIONS

### GreenSource Initiative™

Metal and packaging components are made from recycled materials. Manufactured using renewable solar energy, produced on site. Returnable to manufacturer at end of life to ensure cradle-to-cradle handling. Packaging contains no chlorofluorocarbons (CFC's). Use of this product may qualify for GreenSource efficacy and recycling rebate(s). Consult [www.bklighting.com/greensource](http://www.bklighting.com/greensource) for program requirements.

### Materials

Furnished in Copper-Free Aluminum (Type 6061-T6).

### Body

Fully machined from solid billet. Unibody design provides enclosed, water-proof wireway and integral heat sink for maximum component life. High temperature, silicone 'O' Ring provides water-tight seal.

### Cap

Fully machined. Accommodates [2] lens or louver media. Choose from 1" deep bezel with 90° cutoff ('B' or 'E') or flush lens ('C') cap styles. 'B' caps include weep-hole for water and debris drainage. 'E' caps exclude weep-hole and are for interior use only.

### Lens

Shock resistant, tempered, glass lens is factory adhered to fixture cap and provides hermetically sealed optical compartment.

### BKSSL®

Integrated solid state system with 'X' technology is scalable for field upgrade. Modular design with electrical quick disconnects permit field maintenance. Minimum 50,000 hour rated life at 70% of initial lumens (L70). BKSSL technology provides long life, significant energy reduction and exceptional thermal management.

### Color Management

Chip on board technology delivers natural white light. Exact color point conformity exceeds ANSI C78.377 standard. Module exceeds 80 CRI (RA>80, R9.16). Color point uniformity 2 SDCM color control for 2.7K-4K CCT.

### Remote Driver

For use with remote LED Driver. See remote driver submittal(s) to determine remote distance, dimming range, and wiring requirements prior to detailing field installation of any remote wiring.

### Installation

5" dia., machined canopy with machined aluminum mounting ring permits mounting to 4" octagonal junction box (by others).

### Optics

Interchangeable OPTIKIT™ modules permit field changes to optical distribution.

### Wiring

PVC coated, 18AWG, 150V, 60°C rated and certified to UL 1838 standard.

### Hardware

Tamper-resistant, stainless steel hardware. Canopy mounting screws are additionally black oxide treated for additional corrosion resistance.

### Finish

StarGuard®, our exclusive RoHS compliant, 15 stage chromate-free process cleans and conversion coats aluminum components prior to application of Class 'A' TGIC polyester powder coating.

### Warranty

5 year limited warranty.

### Certification and Listing

ITL tested to IESNA LM-79. Lighting Facts Registration per USDOE ([www.lightingfacts.com](http://www.lightingfacts.com)). ETL Listed to ANSI/UL Standard 1598 and Certified to CAN/CSA Standard C22.2 No. 250. RoHS compliant. Suitable for indoor or outdoor use. Suitable for use in wet locations. IP66 Rated. Made in USA.



# B-K LIGHTING

40429 Brickyard Drive • Madera, CA 93636 • USA  
559.438.5800 • FAX 559.438.5900  
[www.bklighting.com](http://www.bklighting.com) • [info@bklighting.com](mailto:info@bklighting.com)

SUBMITTAL DATE  
02-10-15

DRAWING NUMBER  
SUB-2363-00

# GREG DAY Lighting

# Type A

# See Schedule for Ordering Info

**Canal Plaza**  
CORE DRILL

## LOUVERED BRICK STAR™

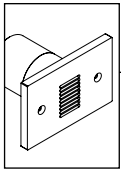

<b>PROJECT:</b>	
<b>TYPE:</b>	
<b>CATALOG NUMBER:</b>	
<b>SOURCE:</b>	
<b>NOTES:</b>	

### CATALOG NUMBER LOGIC

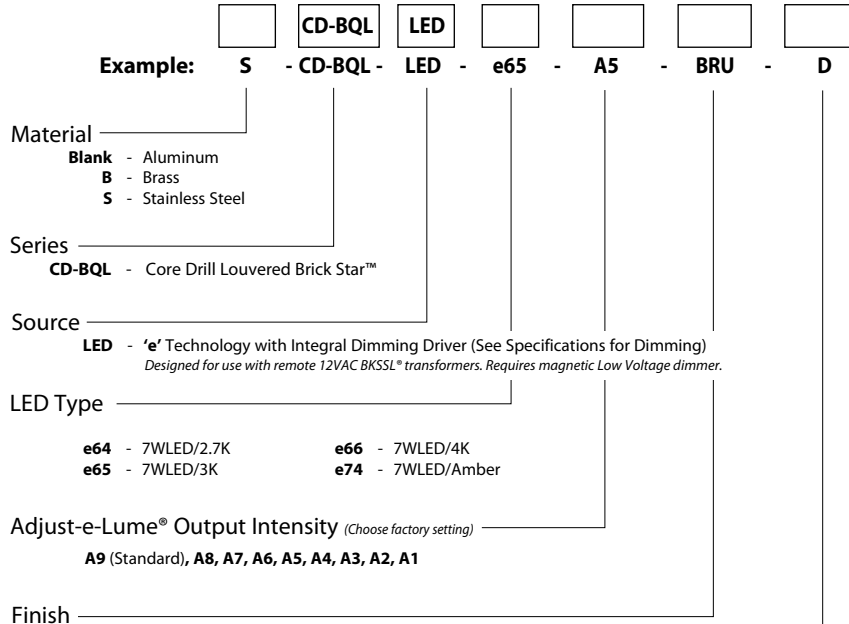

Aluminum Finish			Brass Finish		Premium Finish		
<b>Powder Coat Color</b>	<b>Satin</b>	<b>Wrinkle</b>	Machined	<b>MAC</b>	<b>ABP</b> Antique Brass Powder	<b>CMG</b> Cascade Mountain Granite	<b>RMG</b> Rocky Mountain Granite
Bronze	<b>BZP</b>	<b>BZW</b>	Polished	<b>POL</b>	<b>AMG</b> Aleutian Mountain Granite	<b>CRI</b> Cracked Ice	<b>SDS</b> Sonoran Desert Sandstone
Black	<b>BLP</b>	<b>BLW</b>	Mitique™	<b>MIT</b>	<b>AQW</b> Antique White	<b>CRM</b> Cream	<b>SMG</b> Sierra Mountain Granite
White (Gloss)	<b>WHP</b>	<b>WHW</b>	Stainless Finish		<b>BCM</b> Black Chrome	<b>HUG</b> Hunter Green	<b>TXF</b> Textured Forest
Aluminum	<b>SAP</b>	—	Machined	<b>MAC</b>	<b>BGE</b> Beige	<b>MDS</b> Mojave Desert Sandstone	<b>WCP</b> Weathered Copper
Verde	—	<b>VER</b>	Polished	<b>POL</b>	<b>BPP</b> Brown Patina Powder	<b>NBP</b> Natural Brass Powder	<b>WIR</b> Weathered Iron
			Brushed	<b>BRU</b> <small>Interior use only.</small>	<b>CAP</b> Clear Anodized Powder	<b>OCP</b> Old Copper	<i>Also available in RAL Finishes See submittal SUB-1439-00</i>

**Louver**  
**D** - Rectangular, 30°

DRIVER DATA	Input Volts	InRush Current	Operating Current	Dimmable	Operation Ambient Temperature
	12VAC/DC 50/60Hz	250mA (non-dimmed)	700mA	Magnetic Low Voltage Dimmer	-10°F-130°F

#### LM79 DATA

BK No.	CCT (Typ.)	Input Watts (Typ.)	CRI (Typ.)
e64	2700K	7.0	80
e65	3000K	7.0	80
e66	4000K	7.0	80
e74	Amber (590nm)	7.0	~

#### L70 DATA

Minimum Rated Life (hrs.) 70% of initial lumens(L70)
50,000
50,000
50,000
50,000

<b>B-K LIGHTING</b>	40429 Brickyard Drive • Madera, CA 93636 • USA 559.438.5800 • FAX 559.438.5900 www.bklighting.com • info@bklighting.com	RELEASED 06-03-16	DRAWING NUMBER SUB001023
	THIS DOCUMENT CONTAINS PROPRIETARY INFORMATION OF B-K LIGHTING, INC. AND ITS RECEIPT OR POSSESSION DOES NOT CONVEY ANY RIGHTS TO REPRODUCE, DISCLOSE ITS CONTENTS, OR TO MANUFACTURE, USE OR SELL ANYTHING IT MAY DESCRIBE. REPRODUCTION, DISCLOSURE OR USE WITHOUT SPECIFIC WRITTEN AUTHORIZATION OF B-K LIGHTING, INC. IS STRICTLY FORBIDDEN.		

# See Schedule for Ordering Info

Canal Plaza  
CORE DRILL

## LOUVERED BRICK STAR™

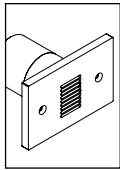

**BKSSL**  
SOLID STATE LIGHTING



PROJECT:	
TYPE:	

**SIDE VIEW**

**FACEPLATE DETAIL**

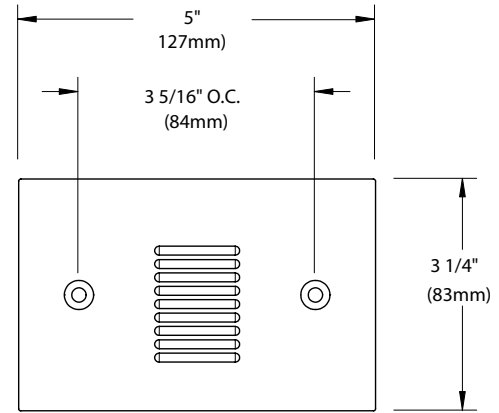
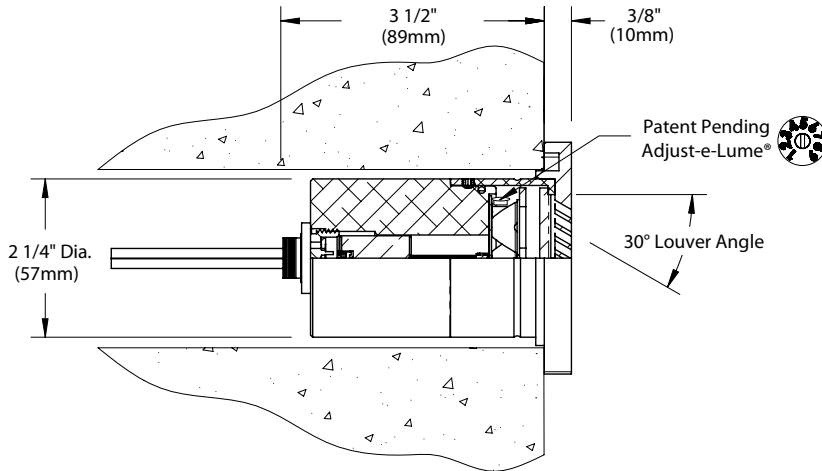

**Accessories** (Configure separately)

**Remote options:**

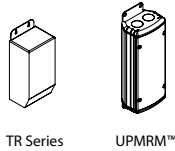

All dimensions indicated on this submittal are nominal.  
Contact Technical Sales if you require more stringent specifications.

## SPECIFICATIONS

**GreenSource Initiative™**

Metal and packaging components are made from recycled materials. Manufactured using renewable solar energy, produced on site. Returnable to manufacturer at end of life to ensure cradle-to-cradle handling. Packaging contains no chlorofluorocarbons (CFC's). Use of this product may qualify for GreenSource efficacy and recycling rebate(s). Consult [www.bklighting.com/greensource](http://www.bklighting.com/greensource) for program requirements.

**Materials**

Furnished in Copper-Free Aluminum (Type 6061-T6), Brass (Type 360) or Stainless Steel (Type 304).

**Core Drill**

Allows for mounting into existing structures that will not easily accept a standard box. 2-1/2" dia. hole required for slip fit.

**Body**

Fully machined from solid billet. Unibody design provides enclosed, water-proof wireway and integral heat sink for maximum component life. High temperature, silicone 'O' Ring provides water-tight seal. Provided with hard-coat (Type III) black anodize finish for maximum corrosion resistance. Weather-tight cable connector with 5'0," 18Ga., 2 wire low voltage cable.

**Faceplate**

Fully machined from solid billet. Countersunk holes provide for flush hardware mounting (by others).

**Louvers and Cutoff**

Louver pattern is machined into faceplate to prevent direct view to the source at nadir. 30° optical cutoff for mounting heights well below typical visual glare angles.

**Lens**

Shock resistant, tempered, glass lens is factory adhered to faceplate and provides hermetically sealed optical compartment.

**BKSSL®**

Integrated solid state system with 'e' technology is scalable for field upgrade. Modular design with electrical quick disconnects permit field maintenance. High power, forward throw source complies with ANSI C78.377 binning requirements. Exceeds ENERGY STAR® lumen maintenance requirements. LM-80 certified components.

Integral, constant current driver. 12VAC/VDC input. 50/60Hz. Proprietary input control scheme achieves power factor correction and eliminates inrush current. Output, over-voltage, open-circuit, and short circuit protected. Inrush current limited to <1A (non-dimming). Conforms to Safety Std. C22.2 No. 250.13-12.

**Dimming**

Line voltage dimmable via magnetic low voltage dimmer. For use with low voltage dimmer with dedicated neutral conductor. For purposes of dimming: Remote magnetic transformer with BKSSL® Power of 'e' technology loads should be loaded to 25% of the transformer VA (watts) rated value.

**Optics**

Rectilinear design provides wide lateral distribution and long forward throw.

**Adjust-e-Lume®** (Pat. Pending)

Integral electronics allows dynamic lumen response at the individual fixture. Indexed (100% to 25% nom.) lumen output. Maintains output at desired level or may be changed as conditions require. Specify factory preset output intensity.

**Remote Transformer**

For use with 12VAC BKSSL remote transformer or magnetic transformers only. B-K Lighting cannot guarantee performance with third party manufacturers' transformers.

**Wiring**

Teflon® coated, 18AWG, 600V, 250° C rated and certified to UL 1659 standard. Anti-Siphon Valve (ASV™) prevents "wicking" through conductor insulation.

**Hardware**

Tamper-resistant, stainless steel hardware. Mounting hardware by others.

**Finish**

StarGuard®, our exclusive RoHs compliant, 15 stage chromate-free process cleans and conversion coats aluminum components prior to application of Class 'A' TGIC polyester powder coating. Brass components are available in powder coat or handcrafted metal finish. Stainless steel components are available in handcrafted metal finish. (Brushed finish for interior use only).

**Warranty**

5 year limited warranty.

**Certification and Listing**

ITL tested to IESNA LM-79. UL Listed. Certified to CAN/CSA/ANSI Standards. RoHs compliant. Suitable for indoor or outdoor use. Suitable for installation in combustible materials (Type Non-IC). Suitable for use in wet locations. Suitable for installation within 4' of the ground. IP65 Rated. Made in USA.



\*Teflon is a registered trademark of DuPont Corporation.  
\*Energy Star is a registered trademark of the United States Environmental Protection Agency.

<b>B-K LIGHTING</b>	40429 Brickyard Drive • Madera, CA 93636 • USA 559.438.5800 • FAX 559.438.5900 <a href="http://www.bklighting.com">www.bklighting.com</a> • <a href="mailto:info@bklighting.com">info@bklighting.com</a>	RELEASED	DRAWING NUMBER
		06-03-16	SUB001023

**GREG DAY Lighting**

**Type C**





100V 115/120V 230/240V



## GENERAL INFORMATION

ETC's Desire Series D60XTI brings the amazing control of the x7 color system™ and the long throw of a D60 to your facility for permanent installation. With its IP66 rating, this luminaire is ready for mounting inside or outside- wherever you need it. The Selador® x7 color system produces the widest range of spectrally-balanced saturated and tinted color choices available. The D60XTI offers a rugged die-cast enclosure, noiseless fan-free operation and multiple lens options that can be changed on site.

### D60XTI LED ARRAY OPTIONS

D60XTI luminaires are based on the x7 color system that uses seven different LED colors to achieve true, usable broad spectrum color. The D60XTI luminaire is available with any one of the following x7 color arrays to best suit the intended application:

- D60XTI Vivid™ – the x7 color system array balanced for best all-around use as a color-changing wash luminaire
- D60XTI Lustr+™ – optimized with six colors plus high-intensity white LEDs to create an ideal front-light wash fixture. Full range color, with an emphasis on lighter colors and white
- D60XTI Ice™ – uses the cool colors of the x7 system to provide extra-high brightness color in the blue end of the spectrum
- D60XTI Fire™ – uses the warm colors of the x7 system to provide extra-high brightness color in the red end of the spectrum
- D60XTI Studio HD™ – Studio HD combines warm white and cool white LEDs for variable color temperature mixing. Added to this are five carefully chosen LED colors from the Selador x7 color system to fill in the white LED spectral gaps. D60XTI Studio HD provides the richest variable white light possible in an LED luminaire

Also available in the following static white arrays:

- D60XTI Studio Daylight™ – Studio Daylight contains sixty 5600K LEDs for high-intensity, non-variable cool-white output
- D60XTI Studio Tungsten™ – Studio Tungsten contains sixty 3000K LEDs for high-intensity, non-variable warm-white output

## ORDERING INFORMATION

### Selador D60XTI

MODEL	DESCRIPTION
SELD60XTI-V	D60XTI Vivid wash luminaire
SELD60XTI-L	D60XTI Lustr+ front-light wash luminaire
SELD60XTI-F	D60XTI Fire special wash luminaire
SELD60XTI-I	D60XTI Ice special wash luminaire
SELD60XTI-H	D60XTI Studio HD wash luminaire
SELD60XTI-D	D60XTI Studio Daylight wash luminaire
SELD60XTI-T	D60XTI Studio Tungsten wash luminaire

Note: D60XTI luminaires ship with a hanging yoke, attached leads and a data termination board. C-clamp, lenses and other accessories are not included.

SPECIFICATIONS

**GENERAL**

- Easy setup via any RDM device, such as ETC Gateways and Gadget
- 60 LED variable color-mixing light wash luminaire (color-mixing luminaires)
- 60 LED white-light wash luminaire (static white luminaires)
- ETL listed to UL1598
- IP66-rated for exterior wet-location use
- Data termination board for easy installation (included)

**PHYSICAL**

- Rugged die-cast, all-metal housing
- Accessory ring for installation of secondary lenses
- Available in black (standard), white or silver (optional) or custom colors (contact factory)
- Hanging yoke standard.
- Cable diameter: power 0.36" / data 0.34"
- Effective Projected Area (EPA): 0.95

**ELECTRICAL**

- 100VAC to 240VAC 50/60Hz universal power input
- Waterproof, 72" outdoor-rated power lead
- Up to 10 fixtures (15A max) may be fed on the same circuit
- Requires power from a non-dimmable source
- Inrush
  - 120V: 46A (First half-cycle)
  - 240V: 77A (First half-cycle)

**LED\***

- 50,000-hour LED life (50,000 hours to 70% intensity)
- 60 LUXEON® Rebel LED emitters
- Studio Daylight and Studio Tungsten use Rebel ES white light emitters for higher output

\*See additional LED notes on page three

**COLOR**

- Exclusive x7 color system seven-color LED array
- Broad spectrum color interacts seamlessly with conventional sources
- Beautifully illuminates skin tones and other objects for a natural appearance and high color rendering
- Exclusive red-shift option emulates tungsten dimming performance (not available on static white luminaires)
- Studio HD array uses warm and cool white light emitters with additional deep-color emitters to allow variable color temperature from 2700K-6500K
- Studio Tungsten and Studio Daylight provide good color rendering at very high brightness

**OPTICAL**

- Primary field angle of 17° and beam angle of 8°
- Secondary lenses available for multiple beam spread options
- Lenses must be ordered separately
- Refer to accessories chart for lenses available

**CONTROL**

- DMX512 in and thru via termination board (included)
- See DMX Input Channel Profiles for operation modes
- 15-bit virtual dimming engine provides smooth, high-quality theatrical fades and minimizes color shift during dimming
- RDM functionality for address and setting changes

SPECIFICATIONS

**THERMAL**

- Ambient operating temperature of -4° to 104°F (-20° to 40°C)
- Active electronic thermal management for droop-free operation
- Noiseless, fan-free convection cooling for acoustically sensitive installations
- Luminaire is designed for continuous operation up to 104°F (40°C) ambient temperature and requires free flow of air around luminaire housing

ADDITIONAL ORDERING INFORMATION

**Fixtures Accessories**

MODEL	DESCRIPTION
D40XTIWM	Wall-Mount Kit (black)
D40XTIWM-1	Wall-Mount Kit (white)
D40XTISPM	Single Pole Mount Kit (black)
D40XTISPM-1	Single Pole Mount Kit (white)
D40XTIDPM	Double Pole Mount Kit (black)
D40XTIDPM-1	Double Pole Mount Kit (white)
D60XTIL	Egg Crate (black)
D60XTIL-1	Egg Crate (white)
D60XTIHH	Half-Shield (black)
D60XTIHH-1	Half-Shield (white)
400CC	C-Clamp (does not ship with luminaire)
400SC	Safety Cable (32")

ADDITIONAL ORDERING INFORMATION

Secondary Lens Options

<b>MODEL</b>	<b>DESCRIPTION:</b> The following lenses are cut for D60XTI luminaires and create round, linear or oblong field patterns as described below. These lenses are not for use in Selador Classic™ (Vivid, Lustr®, Paletta™, etc.) fixtures.
<b>Narrow Linear Field</b>	Note: This is the same material as Selador Classic lenses. Not UV-stable, not for outdoors.
<b>Round Field</b>	Any one of the following round lenses may be installed permanently in the luminaires at the factory as a special order. UV-stable for outdoor use.
D60XTI-RVN	Very Narrow lens (round field)
D60XTI-RN	Narrow lens (round field)
D60XTI-RM	Medium lens (round field)
D60XTI-RW	Wide lens (round field)
D60XTI-RXW	Extra Wide lens (round field)
<b>Oblong Field</b>	UV-stable for outdoor use
D60XTI-ON	Narrow lens (oblong field)
D60XTI-OM	Medium lens (oblong field)
D60XTI-OW	Wide lens (oblong field)

[http://www.etconnect.com/docs/docs\\_downloads/miscdocs/Desire vs PAR EA revB.pdf](http://www.etconnect.com/docs/docs_downloads/miscdocs/Desire_vs_PAR_EA_revB.pdf)

Typical Lens Field Profiles

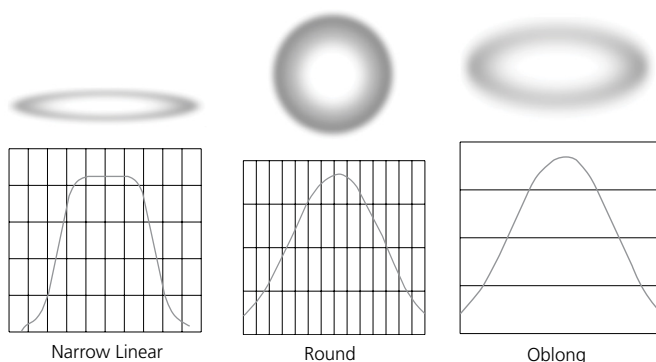

Power Consumption at Full Intensity (Average)

MODEL	VOLTAGE (V)	CURRENT (A)	WATTS
D60XTI	120 / 240	1	124

NOTES ABOUT LED LUMINAIRES

All LED sources experience some lessening of light output and color shift over time. LED output will vary with thermal conditions, which can be affected by ambient temperatures and orientation (see the D40 Ambient Temperature and Power Budgeting Guide for more details). Based on the LED manufacturer's B50 L70 specification, a Selador luminaire will achieve ~70% of its initial output after 50,000 hours of typical usage. In individual situations, LEDs will be used for different durations and at different levels. This can eventually lead to minor alterations in color performance, necessitating slight adjustment to presets, cues or programs.

CRI AND CQS RATINGS

Desire luminaires were evaluated for CRI and CQS performance using measured output spectrum and optimized mix solutions for a best spectral match to black body sources at 3200K and 5600K.

Fixture	CRI	CQS	Color Fidelity	Duv
D60XTI Vivid at 3200K	87	89	89	0.000
D60XTI Vivid at 5600K	90	92	92	0.000
D60XTI Lustr+ at 3200K	86	88	88	0.000
D60XTI Lustr+ at 5600K	93	92	90	0.000
D60XTI Studio HD at 3200K	89	90	91	0.000
D60XTI Studio HD at 5600K	92	94	94	0.000
D60XTI Studio Daylight at 5600K	71	70	69	0.001
D60XTI Studio Tungsten at 3000K	86	86	86	0.001

All D60XTI Studio luminaire versions provide excellent color rendering to the eye, particularly at higher color temperature settings such as 5600K. In most cases the Duv is 0.000. A Duv rating of 0.000 indicates that the color mix used is exactly on the black body line, with no green or magenta tint.

Notes to videographers:

- All Desire luminaires use LUXEON Rebel ES emitters specified by the strictest binning standards. However, on-camera LED response varies with different cameras and settings. Daylight LEDs can appear slightly greener than other 5600K sources on camera.
- Luminaires with non-variable single-color daylight arrays such as Studio Daylight may use standard color correction filters (Rosco 3314, Rosco 3316 or similar) to achieve the desired on-camera result.
- Camera tests using your specific set up are recommended to determine the best configuration.

## LENS INFORMATION

## Desire diffusion angle measurements

NOMINAL									
	No Lens	Very Narrow	Narrow	Medium	Wide	Extra Wide	Narrow Oval	Medium Oval	Wide Oval
<b>D60XTI</b>		25°	35°	45°	75°	N/A	20° x 40°	30° x 70°	35° x 80°
<b>LUSTR+</b>	18	22	27	42	69	104	20 x 37	25 x 60	30 x 82
<b>VIVID</b>	18	22	27	42	69	104	20 x 37	25 x 60	30 x 82
<b>FIRE</b>	18	23	28	42	69	103	21 x 38	25 x 60	30 x 82
<b>ICE</b>	18	22	28	42	69	99	20 x 37	25 x 60	30 x 82
<b>STUDIO HD</b>	18	23	28	42	69	104	21 x 29	25 x 61	30 x 82
<b>STUDIO D</b>	22	25	30	43	70	105	24 x 39	28 x 62	32 x 80
<b>STUDIO T</b>	23	25	30	43	70	105	24 x 39	28 x 62	32 x 80

Values in black refer to old lens descriptions.

CONTROL OPTIONS

User settings on D60XTI luminaires allow multiple operational modes and settings for console operation via DMX protocol. Some of the setting options are:

- Multiple DMX options ranging from a simple RGB profile – which effectively controls all seven LED colors via three channels – to nine-channel direct color and intensity control
- Multiple dimming curve options
- Preset colors and sequences for stand-alone (no console required) operation
- White point selection – white light and color behavior based on a specific color temperature white light (i.e. 3200K, 5600K, etc)
- Loss of data behavior options – instant-off, hold last look for two minutes, etc.
- Output modes – three output options that offer the user a choice between maximum output and maximum consistency

See the user manual for a complete explanation of all of the control settings and options for the D60XTI

Quick Setups

To assist in managing the numerous control and luminaire behavior choices, five combinations of operational settings are available to quickly get started. These settings are specifically created for different applications and are easily accessible at the luminaire display. Each setting can then be modified as required to take advantage of all of the possible control features.

Setting Title	Profile	Description	Typical Features*
General	Direct	Factory default: For general purpose use including interior architectural applications.	<ul style="list-style-type: none"> <li>• Standard dimming curve</li> <li>• Regulated output for color consistency</li> </ul>
Stage	HSI Plus 7 Enabled	Theatrical lighting: Duplicates the color and dimming behavior of tungsten stage lighting fixtures.	<ul style="list-style-type: none"> <li>• Incandescent dimming curve</li> <li>• Regulated output for color consistency</li> <li>• 3200K white point setting</li> </ul>
XT Arch	HSI	Exterior architectural lighting: Provides a high degree of color consistency in high ambient temperature environments.	<ul style="list-style-type: none"> <li>• Standard dimming curve</li> <li>• Protected output</li> <li>• 3200K white point setting</li> </ul>
High Impact	RGB	Event lighting: Enables quickest response, simple RGB control and strobe channel for maximum effect usage.	<ul style="list-style-type: none"> <li>• Quick dimming curve</li> <li>• Boost mode for maximum intensity</li> <li>• 5600K white point setting</li> </ul>
Studio	Studio	Video/film lighting: Enables three parameter control of white light (intensity, white point and tint) via DMX from console.	<ul style="list-style-type: none"> <li>• Linear dimming curve</li> <li>• Regulated output mode for color consistency</li> </ul>

\*See user manual for complete list of features for each Quick Setup.

CONTROL OPTIONS

DMX Input Channel Profiles

DMX Profile	DMX Channels	Channel Assignments	Notes
Direct	9	1 – Red 2 – Orange (white if Lustr+) 3 – Amber 4 – Green 5 – Cyan 6 – Blue 7 – Indigo 8 – Intensity 9 – Strobe	Direct control of each individual color with a separate master intensity channel. Color calibration of LEDs is not active in this mode. The nine-channel profile will produce the highest quality color crossfades.
HSI	5	1 – Hue (coarse) 2 – Hue (fine) 3 – Saturation 4 – Intensity 5 – Strobe	High-resolution hue (two-channels), saturation and intensity control. HSI mode will produce color crossfades around the color space.
HSIC	6	1 – Hue (coarse) 2 – Hue (fine) 3 – Saturation 4 – Intensity 5 – Strobe 6 – Color Point (CCT)	High-resolution hue, saturation and intensity control as above, with the addition of a color point channel to adjust the color temperature of the luminaire in both white light and color. Color crossfade performance is the same as EHSI.
RGB	5 (Ch. 4 not used)	1 – Red 2 – Green 3 – Blue 4 – n/a 5 – Strobe	Effectively addresses all seven colors via three channels of control. RGB profile will produce medium quality color crossfades.
Studio	3	1 – Intensity 2 – Color Point (CCT) 3 – Tint	Controls luminaire as a white light unit. If no DMX (i.e. console input) is present, fixture can be adjusted for these three parameters on the UI at the back of the unit.

Additional profile options

Plus 7	Seven additional color control channels are available in RGB, HSI, HSIC and Studio profile settings. For example: HSI with Plus 7 enabled becomes a 14-channel profile-	<ul style="list-style-type: none"> <li>1 – Hue (coarse)</li> <li>2 – Hue (fine)</li> <li>3 – Saturation</li> <li>4 – Intensity</li> <li>5 – Strobe</li> <li>6 – n/a</li> <li>7 – Plus 7 control on/off</li> <li>8 – Red</li> <li>9 – Orange (white if Lustr+)</li> <li>10 – Amber</li> <li>11 – Green</li> <li>12 – Cyan</li> <li>13 – Blue</li> <li>14 – Indigo</li> </ul>	<p>The desired color and intensity is achieved by using the HSI or RGB channels.</p> <p>Placing channel seven at a value over 51% gives the luminaire a 14-channel profile.</p> <p>Channels 8-14 represent the native colors of the luminaire and allow the operator to adjust individual color channels to fine-tune the color output.</p>
Strobe	Variable strobe control: 0% is no strobe. The fixture output will strobe more rapidly as the strobe channel value approaches 100%.		

CONTROL OPTIONS

Studio Daylight and Studio Tungsten (only)

Quick Set-Ups

Setting Title	Profile	Description	Typical Features*
Studio	Studio	Simple mode for linear intensity control	<ul style="list-style-type: none"> <li>• Linear dimming curve</li> <li>• Regulated output for intensity stability</li> </ul>
Single Channel	Direct	For general purpose architectural use	<ul style="list-style-type: none"> <li>• Standard dimming curve</li> <li>• Regulated output for consistency</li> </ul>
Stage	Direct	Matches conventional luminaire performance	<ul style="list-style-type: none"> <li>• Incandescent dimming curve</li> <li>• Regulated output</li> </ul>

CONTROL OPTIONS

DMX Input Channel Profiles

DMX Profile	DMX Channels	Channel Assignments	Notes
Studio	3	1 – Intensity 2 – Strobe 3 – N/A (only used in D60)	Control of parameters is also enabled from the luminaire's user interface. No console required.
Direct	3	1 – Intensity 2 – Strobe 3 – N/A (only used in D60)	

PHOTOMETRICS

D60XTI Vivid™

Mode	Degree	Candela	Field Lumens	Beam Lumens	Lumens Per Watt
Boost - cold	17°	170,540	3,760	1,667	31.9
Regulated	17°	132,451	3,050	1,305	30

Metric conversions: For meters, multiply feet by 0.3048  
For lux, multiply footcandles by 10.76

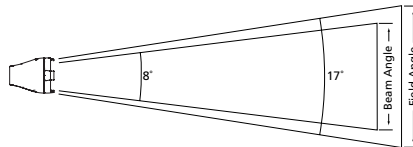

Throw Distance (d)	10.0'	15.0'	20.0'	25.0'	319'
	3.0m	4.6m	6.1m	7.6m	97m
Field Diameter	3.0'	4.4'	5.9'	7.4'	-
	.9m	1.4m	1.8m	2.3m	
Illuminance (fc)	1,617	719	404	259	1
Illuminance (lux)	17,405	7,736	4,351	2,785	10.76

To determine center beam illumination in footcandles at any throw distance, divide candela by the throw distance squared

For field diameter at any distance, multiply distance by 0.295  
For beam diameter at any distance, multiply by 0.145

Cosine Candela Plot

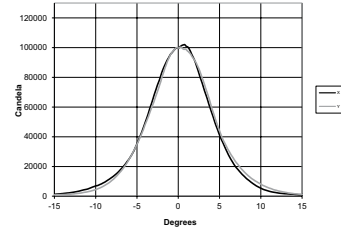

Iso-Illuminance Diagram (Flat Surface Distribution)

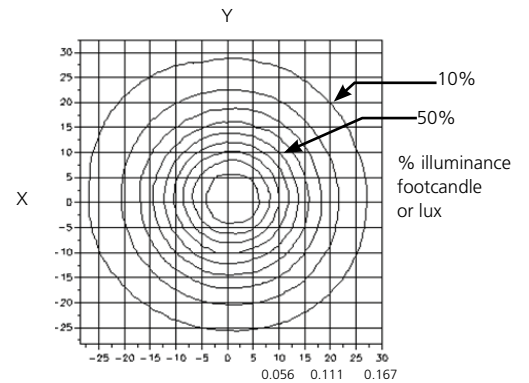

D60XTI Lustr+™

Mode	Degree	Candela	Field Lumens	Beam Lumens	Lumens Per Watt
Boost - cold	16°	195,012	4,317	1,931	34.9
Regulated	16°	180,097	3,850	1,748	34.3

Metric conversions: For meters, multiply feet by 0.3048  
For lux, multiply footcandles by 10.76

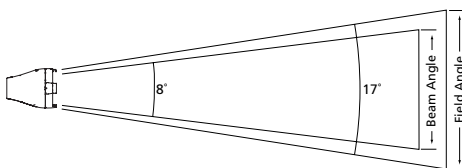

Throw Distance (d)	10'	15.0'	20.0'	25.0'	348'
	3.0m	4.6m	6.1m	7.6m	106m
Field Diameter	2.9'	4.3'	5.8'	7.2'	-
	.9m	1.3m	1.8m	2.2m	
Illuminance (fc)	1,828	812	457	292	1
Illuminance (lux)	19,676	8,745	4,919	3,148	10.76

To determine center beam illumination in footcandles at any throw distance, divide candela by the throw distance squared

For field diameter at any distance, multiply distance by 0.288  
For beam diameter at any distance, multiply by 0.112

Cosine Candela Plot

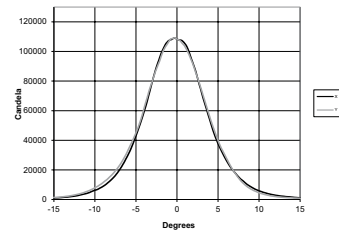

Iso-Illuminance Diagram (Flat Surface Distribution)

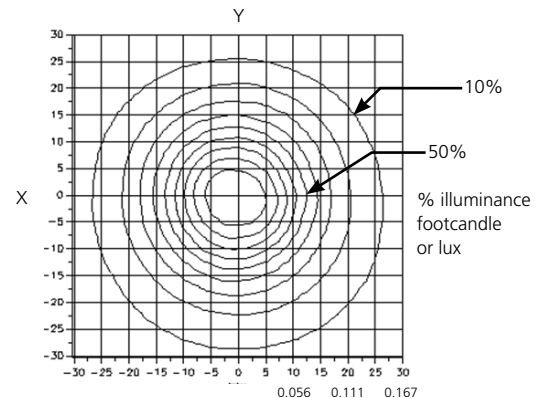

PHOTOMETRICS

D60XTI Fire

Mode	Degree	Candela	Field Lumens	Beam Lumens	Lumens Per Watt
Boost - cold	17°	177,597	4,112	1,866	37.9
Regulated	17°	133,760	3,075	1,399	36.6

Metric conversions: For meters, multiply feet by 0.3048  
For lux, multiply footcandles by 10.76

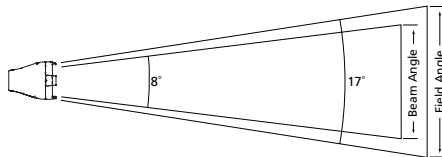

Throw Distance (d)	10.0'	15.0'	20.0'	25.0'	412'
	3.0m	4.6m	6.1m	7.6m	125.7m
Field Diameter	3.0'	4.5'	6.0'	7.5'	-
	.9m	1.4m	1.8m	2.3m	-
Illuminance (fc)	1,701	756	425	272	1
Illuminance (lux)	18,309	8,138	4,577	2,930	10.76

To determine center beam illumination in footcandles at any throw distance, divide candela by the throw distance squared

For field diameter at any distance, multiply distance by 0.301  
For beam diameter at any distance, multiply by 0.144

Cosine Candela Plot

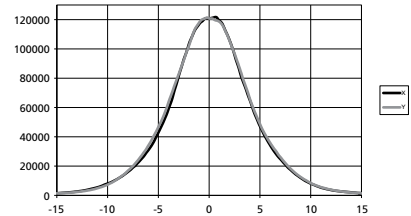

Iso-Illuminance Diagram (Flat Surface Distribution)

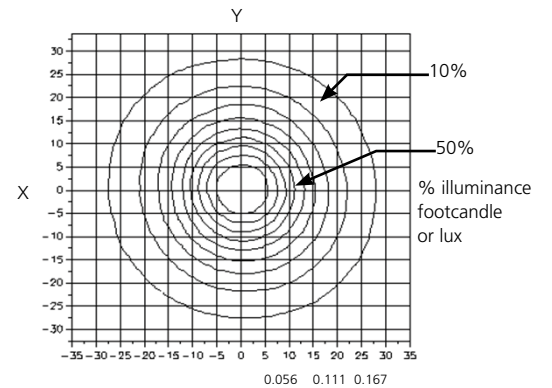

D60XTI Ice

Mode	Degree	Candela	Field Lumens	Beam Lumens	Lumens Per Watt
Boost - cold	16°	118,965	2,526	1,243	19.7
Regulated	16°	109,877	2,332	1,149	18.8

Metric conversions: For meters, multiply feet by 0.3048  
For lux, multiply footcandles by 10.76

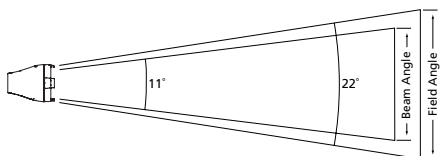

Throw Distance (d)	10.0'	15.0'	20.0'	30.0'	358.3'
	3.0m	4.6m	6.1m	9.1m	109.2m
Field Diameter	2.8'	4.2'	5.6'	7.0'	-
	.8m	1.3m	1.7m	2.1m	-
Illuminance (fc)	1,284	571	321	205	1
Illuminance (lux)	13,821	6,143	3,455	2,211	10.76

To determine center beam illumination in footcandles at any throw distance, divide candela by the throw distance squared

For field diameter at any distance, multiply distance by 0.278  
For beam diameter at any distance, multiply by 0.142

Cosine Candela Plot

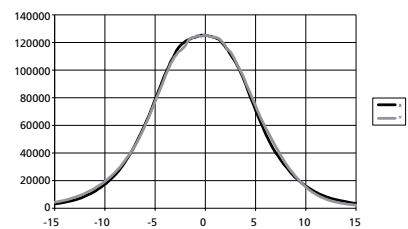

Iso-Illuminance Diagram (Flat Surface Distribution)

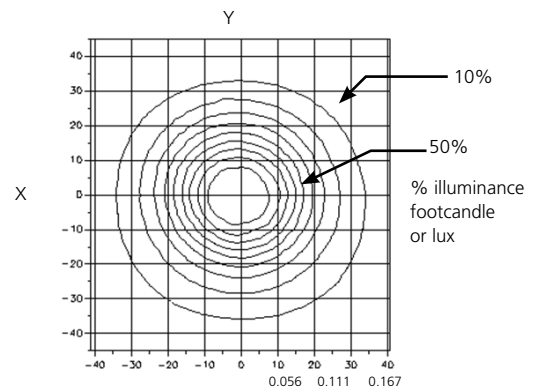



PHOTOMETRICS

D60XTI Studio HD

Mode	Degree	Candela	Field Lumens	Beam Lumens	Lumens Per Watt
Boost - cold	16°	198,209	4,532	1,916	33.4
Regulated	16°	185,414	4,224	1,780	33.7

Metric conversions: For meters, multiply feet by 0.3048  
For lux, multiply footcandles by 10.76

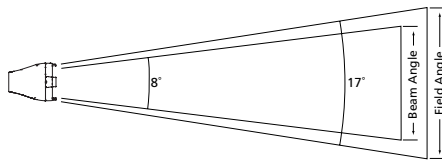

Throw Distance (d)	10.0'	15.0'	20.0'	25.0'	471.4'
	3.0m	4.6m	6.1m	7.6m	143.7m
Field Diameter	2.8'	4.2'	5.6'	7.0'	-
	0.9m	1.3m	1.7m	2.1m	-
Illuminance (fc)	2,222	988	556	356	1
Illuminance (lux)	23,917	10,630	5,979	3,827	10.76

To determine center beam illumination in footcandles at any throw distance, divide candela by the throw distance squared

For field diameter at any distance, multiply distance by 0.281  
For beam diameter at any distance, multiply by 0.142

Cosine Candela Plot

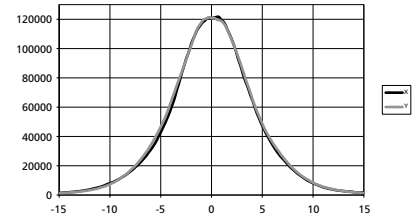

Iso-Illuminance Diagram (Flat Surface Distribution)

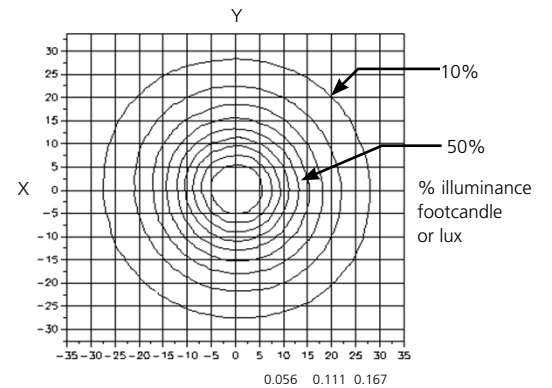

D60XTI Studio Daylight

Mode	Degree	Candela	Field Lumens	Beam Lumens	Lumens Per Watt
Boost - cold	22°	209,556	8,216	4,068	55.3
Regulated	22°	193,045	7,610	3,860	54.8

Metric conversions: For meters, multiply feet by 0.3048  
For lux, multiply footcandles by 10.76

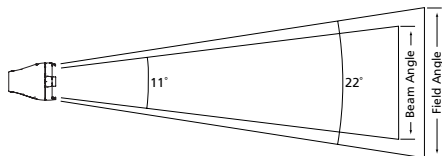

Throw Distance (d)	10'	15'	20'	25'	435.3'
	3.0m	4.6m	6.1m	7.6m	132.7m
Field Diameter	3.9'	5.8'	7.7'	9.7'	-
	1.2m	1.8m	2.4m	2.9m	-
Illuminance (fc)	1,895	842	474	303	1
Illuminance (lux)	20,398	9,066	5,099	3,264	10.76

To determine center beam illumination in footcandles at any throw distance, divide candela by the throw distance squared

For field diameter at any distance, multiply distance by 0.387  
For beam diameter at any distance, multiply by 0.194

Cosine Candela Plot

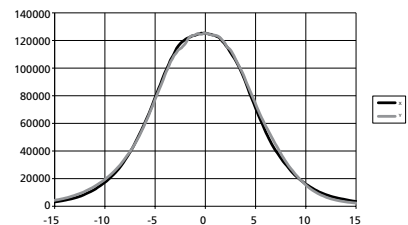

Iso-Illuminance Diagram (Flat Surface Distribution)

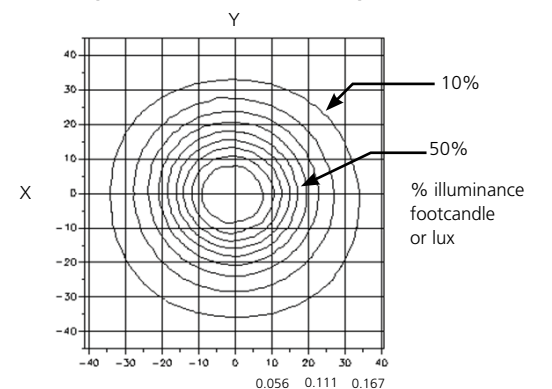

PHOTOMETRICS

D60XTI Studio Tungsten

Mode	Degree	Candela	Field Lumens	Beam Lumens	Lumens Per Watt
Boost - cold	23°	171,089	6,482	3,001	43.2
Regulated	23°	162,409	6,172	2,918	39.6

Metric conversions: For meters, multiply feet by 0.3048  
 For lux, multiply footcandles by 10.76

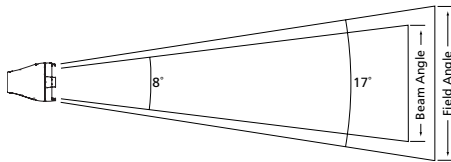

Throw Distance (d)	10'	15'	20'	25'	373.6'
	3.0m	4.6m	6.1m	7.6m	113.9m
Field Diameter	4.1'	6.2'	8.3'	10.4'	-
	1.3m	1.9m	2.5m	3.2m	-
Illuminance (fc)	1,395	620	349	223	1
Illuminance (lux)	15,020	6,676	3,755	2,403	10.76

For field diameter at any distance, multiply distance by 0.414  
 For beam diameter at any distance, multiply by 0.189

Throw Distance Multiplier (TDM)

To determine the distance from the center of the beam (Origin) to a certain illuminance level at a particular distance, multiply the desired throw distance by the TDM desired on the Iso-Illuminance diagram.

Throw Distance (TD) x Throw Distance Multiplier (TDM) = Distance from the Origin (DfO) (distance from the center of the beam)

Example: 25 feet (TD) x 0.047 (TDM) = 1.175 feet from center of beam (DfO)

For illumination with any lamp, multiply the candlepower of a beam spread by the multiplying factor (mf) shown for that lamp.

To determine illumination in footcandles or lux at any throw distance, divide candlepower by distance squared.

Cosine Candela Plot

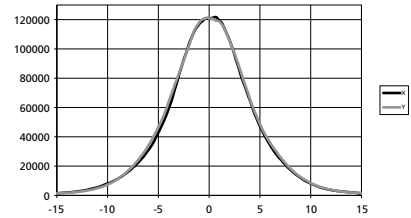

Iso-Illuminance Diagram (Flat Surface Distribution)

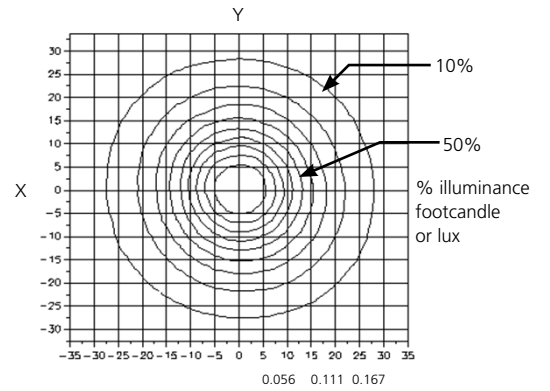

PHYSICAL

Selador D60XTI Weights and Dimensions

Total weight depends on how the individual luminaire is configured.

WEIGHT*		SHIPPING WEIGHT	
lbs	kgs	lbs	kgs
23	10.43	24.7	11.2

\* Does not include mounting hardware

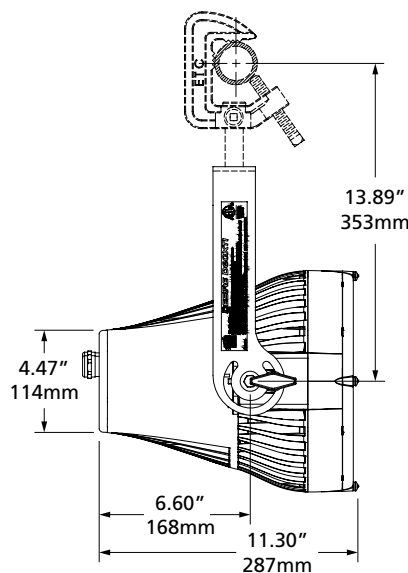
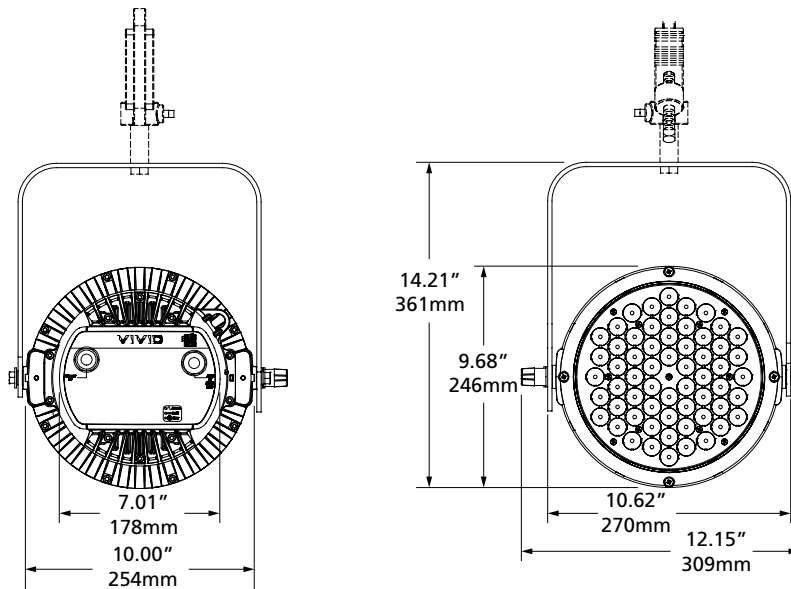

Corporate Headquarters • 3031 Pleasant View Rd, PO Box 620979, Middleton WI 53562 0979 USA • Tel +1 608 831 4116 • Fax +1 608 836 1736

London, UK • Unit 26-28, Victoria Industrial Estate, Victoria Road, London W3 6UU, UK • Tel +44 (0)20 8896 1000 • Fax +44 (0)20 8896 2000

Rome, IT • Via Pieve Torina, 48, 00156 Rome, Italy • Tel +39 (06) 32 111 683 • Fax +44 (0)20 8752 8486

Holzkirchen, DE • Ohmstrasse 3, 83607 Holzkirchen, Germany • Tel +49 (80 24) 47 00-0 • Fax +49 (80 24) 47 00-3 00

Hong Kong • Room 1801, 18/F, Tower 1 Phase 1, Enterprise Square, 9 Sheung Yuet Road, Kowloon Bay, Kowloon, Hong Kong • Tel +852 2799 1220 • Fax +852 2799 9325

Web • www.etcconnect.com • Copyright©2016 ETC. All Rights Reserved. All product information and specifications subject to change. 7410L1013 Rev. E USA 04/2016



100V 115/120V 230/240V

Desire™ Series

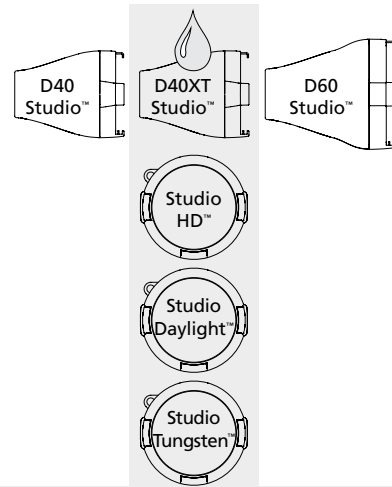

This datasheet covers D40XT Studio fixtures as shown. See other datasheets for other versions.

GENERAL INFORMATION

ETC's Desire Series D40XT Studio lighting fixture puts the newest technology in high-output white-light LEDs into a sealed IP66 outdoor-rated enclosure to create an ideal luminaire for video, film and other 'white light only' applications. Its watertight construction makes it ideal for location lighting. Three different LED options give the user a choice for just the right white light output for the job. The D40XT Studio offers a rugged die-cast enclosure; noiseless, no fan cooling; multiple lens options and advanced user interface. The user interface enables easy configuration and specific features for video and film professionals. The fixture can be configured to operate under console control for studio systems or in stand-alone 'no console required' settings.

D40XT STUDIO LED ARRAY OPTIONS

D40XT Studio fixtures offer three different LED array choices based on specific white-light functions. The D40XT Studio fixture is available with any one of the following color arrays (not interchangeable) to best suit the application.

- D40XT Studio HD™ – Studio HD combines warm white and cool white LEDs for variable color temperature mixing. Added to this are five carefully chosen LED colors from the Selador® x7 Color System™ to fill in the white LED spectral gaps. D40XT Studio HD provides the richest variable white light possible in an LED fixture
- D40XT Studio Daylight™ – Studio Daylight contains forty 5600K LEDs for high-intensity, non-variable cool-white output
- D40XT Studio Tungsten™ – Studio Tungsten contains forty 3000K LEDs for high-intensity, non-variable warm-white output

ORDERING INFORMATION

Selador D40XT Studio

MODEL	DESCRIPTION
SELD40HO	D40 Studio HD wash fixture – IP66-rated fixture for high-intensity variable white light output with broad spectrum richness and color rendering
SELD40DO	D40 Studio Daylight wash fixture – IP66-rated fixture with all 5600K emitters for single color, non-adjustable daylight output
SELD40TO	D40 Studio Tungsten wash fixture – IP66-rated fixture with all 3000K emitters for single color, non-adjustable warm white output

Note: D40XT Studio luminaires ship with hanging yoke and attached leads equipped with watertight Molex power connectors and watertight DMX connectors. C-clamp, lenses or separate power lead are not included. Order DPA-M bare-end to Molex adaptors separately for XT luminaires if required.

SELD40 HO-0X

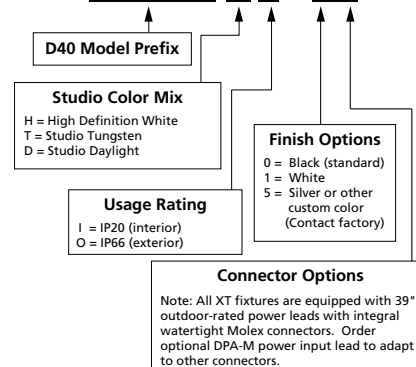

**SPECIFICATIONS**

**GENERAL**

- 40 LED white-light wash fixture
- ETL listed to UL1573 – the standard for stage and studio lighting units
- IP66-rated for exterior wet location use
- Power and DMX in/thru waterproof power leads for easy setup
- User-friendly control interface with multiple modes and fixture settings

**PHYSICAL**

- Rugged die-cast all-metal housing
- Easy access slots for secondary lenses and standard 7.5" PAR accessories
- Available in black (standard), white or silver (optional) or custom colors (contact factory)
- Hanging yoke standard. Optional yoke/floor stand available
- Effective Projected Area (EPA): 0.74

**ELECTRICAL**

- 100VAC to 240VAC 50/60 Hz universal power input
- Waterproof, 39" power in and thru outdoor rated power leads
- Up to 10 fixtures (15A max) may be linked via power thru connector
- Requires power from a non-dim source
- Inrush-
  - 120V / 15A
  - 240V / 40A

**LED\***

- 50,000 hour LED life (50,000 hours to 70% intensity)
- 40 Luxeon® Rebel LED emitters
- Studio Daylight and Studio Tungsten use Rebel ES white light emitters for higher output

\*See additional LED notes on page three

**COLOR**

- Studio HD array uses warm and cool white light emitters with additional deep color emitters to allow variable color temperature from 2700K-6500K
- Studio HD produces variable white light with broad spectrum richness
- Studio HD beautifully illuminates skin tones and other objects for natural appearance and high color rendering
- Studio Tungsten and Studio Daylight provide good color rendering at very high brightness

**OPTICAL**

- Primary field angle of 17° and beam angle of 8°
- Secondary lenses available for multiple beam spread options
- Sealed, factory-installed lenses available for permanent installations (special order)
- Refer to accessories chart for lenses available

**CONTROL**

- DMX512 in and thru via watertight five-pin XLR connectors on 39" leads
- Multiple control options including RGB, strobe, and console-free Master/Slave mode
- See DMX Control Table for additional information
- 15-bit virtual dimming engine provides smooth, high quality theatrical fades and minimizes color shift during dimming
- RDM functionality for address and setting changes

**SPECIFICATIONS**

**THERMAL**

- Ambient operating temperature of -4° to 104°F (-20° to 40°C)
- Active electronic thermal management for droop-free operation
- Noiseless, fan-free convection cooling for acoustically sensitive installations
- Fixture is designed for continuous operation at 104°F (40°C) ambient temperature and requires free flow of air around fixture housing

**ADDITIONAL ORDERING INFORMATION**

**Power Input Cables**

Use information below to order 5' power input leads with factory fitted connectors. Desire D40XT™ and D40XT Studio luminaires ship with 39" outdoor-rated power leads and integral watertight Molex connectors. Order optional DPA-M power cable to adapt to other input connectors

MODEL	DESCRIPTION
DPAM-5*	XT Outdoor UL Power Lead – 1M Molex Female to bare end
DPAM-25*	XT Outdoor UL Power Lead-Long – 25' Molex Female to bare end

\*Not included with fixtures

**Power Pass Thru**

DPJM-5	XT Outdoor UL 5' Molex to Molex Extension
DPJM-10	XT Outdoor UL 10' Molex to Molex Extension

**Fixtures Accessories**

MODEL	DESCRIPTION
SELD40FSY	Yoke with floor stand attachment
400BD	Barn door (Use only as a flexible top hat to diminish aperture glare. Not for beam shaping)
407CF	Color Frame (use for round and oblong lenses)
400L	Egg Crate Louver
400PTH3	Top Hat 3" Tube
400PTH6	Top Hat 6" Tube
400PHH	Half Hat 6" Tube
400CC	C-Clamp (does not ship with fixture)
400SC	Safety Cable (32")

**ADDITIONAL ORDERING INFORMATION**

**Secondary Lens Options**

<b>MODEL</b>	<b>DESCRIPTION:</b> The following lenses are cut for D40™ fixtures and create round, linear or oblong field patterns as described below. These lenses are not for use in Selador® Classic (Vivid™, Lustr®. Paletta™, etc.) fixtures.	
<b>Narrow Linear Field</b>	Note: This is the same material as Selador Classic lenses	
SELLVN-7.5	7.5" Very Narrow lens	Linear lenses may be combined to create desired field size
SELLN-7.5	7.5" Narrow lens	
SELLM-7.5	7.5" Medium lens	
SELLW-7.5	7.5" Wide lens	
SELLEW-7.5	7.5" Extra Wide lens	
<b>Round Field</b>	Any one of the following round lenses may be installed permanently in the fixture at the factory as a special order	
SELRVN-7.5	7.5" Very Narrow lens (round field)	
SELRN-7.5	7.5" Narrow lens (round field)	
SELRM-7.5	7.5" Medium lens (round field)	
SELRW-7.5	7.5" Wide lens (round field)	
<b>Oblong Field</b>		
SELON-7.5	7.5" Narrow lens (oblong field)	
SELOM-7.5	7.5" Medium lens (oblong field)	
SELOW-7.5	7.5" Wide lens (oblong field)	

[http://www.etconnect.com/docs/docs\\_downloads/miscdocs/Desire vs PAR EA revB.pdf](http://www.etconnect.com/docs/docs_downloads/miscdocs/Desire_vs_PAR_EA_revB.pdf)

**Typical Lens Field Profiles**

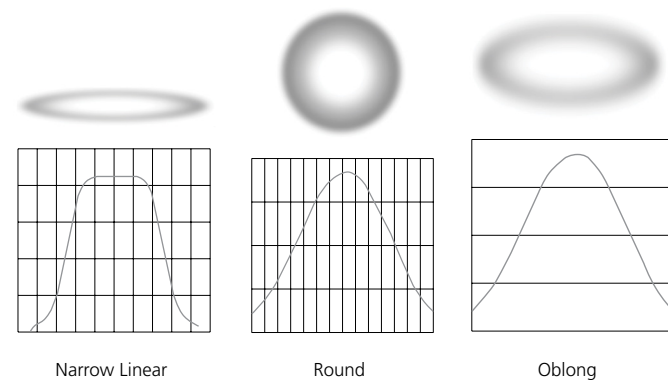

**Power Consumption at Full Intensity**

MODEL	VOLTAGE (V)	CURRENT (A)	WATTS
D40XT Studio	120 / 240	1 / .5	110

**NOTES ABOUT LED LUMINAIRES**

All LED sources experience some lessening of light output and some color shift over time. LED output will vary with thermal conditions. Based on the LED manufacturer's B50 L70 specification, a Selador luminaire will achieve ~70% of its initial output after 50,000 hours of typical usage. In individual situations, LEDs will be used for different durations and at different levels. This can eventually lead to minor alterations in color performance, necessitating slight adjustment to presets, cues or programs.

**CRI AND CQS RATINGS**

Desire fixtures were evaluated for CRI and CQS performance using measured output spectrum and optimized mix solutions for a best spectral match to black body sources at 3200K and 5600K.

Fixture	CRI	CQS	Color Fidelity	Duv
D40 Vivid™ at 3200K	87	89	89	0.000
D40 Vivid at 5600K	90	92	92	0.000
D40 Lustr+™ at 3200K	86	88	88	0.000
D40 Lustr+ at 5600K	93	92	90	0.000
D40 Studio HD™ at 3200K	89	90	91	0.000
D40 Studio HD at 5600K	92	94	94	0.000
D40 Studio Daylight™ at 5600K	71	70	69	0.001
D40 Studio Tungsten™ at 3000K	86	86	86	0.001

All D40XT Studio luminaire versions provide excellent color rendering to the eye, particularly at higher color temperature settings such as 5600K. In most cases the Duv is 0.000. A Duv rating of 0.000 indicates that the color mix used is exactly on the black body line, with no green or magenta tint.

**Notes to Videographers:**

- All Desire fixtures use Luxeon Rebel ES emitters specified by the strictest binning standards. However, on-camera LED response varies with different cameras and settings. Daylight LEDs can appear slightly greener than other 5600K sources on camera.
- Fixtures with non-variable single-color daylight arrays such as Studio Daylight may use standard color correction filters (Rosco 3314, Rosco 3316 or similar) to achieve the desired on-camera result.
- Camera tests using your specific set up are recommended to determine the best configuration.

LENS INFORMATION

**Desire diffusion angle measurements**

NOMINAL									
	No Lens	Very Narrow	Narrow	Medium	Wide	Extra Wide	Narrow Oval	Medium Oval	Wide Oval
<b>D40XT STUDIO</b>		25°	35°	45°	75°	N/A	20° x 40°	30° x 70°	35° x 80°
<b>LUSTR+</b>	22	26	32	54	77	97	29 x 43	33 x 63	33 x 97
<b>VIVID</b>	22	26	32	54	77	97	29 x 43	33 x 63	33 x 97
<b>STUDIO HD</b>	22	26	32	54	77	97	29 x 43	33 x 63	33 x 97
<b>STUDIO D</b>	31	33	38	60	81	97	36 x 48	41 x 68	35 x 97
<b>STUDIO T</b>	31	33	38	60	81	97	36 x 48	41 x 68	35 x 97

Values in black refer to old lens descriptions.



**CONTROL OPTIONS**

**Studio HD**

User settings on D40XT Studio fixtures allow multiple operational modes and settings for either console operation via DMX protocol or stand-alone operation. The expanded LCD display provides easy navigation to all possible settings and options. Some of the setting options are:

- Multiple DMX choices ranging from a simple RGB profile – which effectively controls all seven LED colors via three channels – to nine-channel ‘direct’ color and intensity control
- Multiple dimming curve options
- Preset colors and sequences for stand-alone (no console required) operation
- White point selection – white light and color behavior based on a specific color temperature white light, i.e. 3200K, 5600K, etc
- Loss of data behavior options – instant off, hold last look for two minutes, etc
- Output modes – three output options that offer the user a choice between maximum output and maximum consistency

See the user manual for a complete explanation of all of the control settings and options for the D40XT Studio.

**Quick Setups**

To assist in managing the numerous control and fixture behavior choices, five combinations of operational settings are available to quickly get started. These settings are specifically created for different applications and are easily accessible at the fixture display. Each setting can then be modified as required to take advantage of all of the possible control features.

Setting Title	Profile	Description	Typical Features*
Studio	Studio	Studio Factory Default: Enables three parameter control of white light (intensity, white point, and tint) via DMX from console or from fixture display – no console required	<ul style="list-style-type: none"> <li>• Linear dimming curve</li> <li>• Regulated output mode for color consistency</li> </ul>
General	Direct	For general purpose use including interior architectural applications	<ul style="list-style-type: none"> <li>• Standard dimming curve</li> <li>• Regulated output for color consistency</li> </ul>
Stage	HSI Plus 7 Enabled	Theatrical lighting: Duplicates the color and dimming behavior of tungsten stage lighting fixtures.	<ul style="list-style-type: none"> <li>• Incandescent dimming curve</li> <li>• Regulated output for color consistency</li> <li>• 3200K white point setting</li> </ul>
XT Arch	HSI	Exterior Architectural lighting: Provides a high degree of color consistency in high ambient temperature environments.	<ul style="list-style-type: none"> <li>• Standard dimming curve</li> <li>• Protected output</li> <li>• 3200K white point setting</li> </ul>
High Impact	RGB	Event lighting: Enables quickest response, simple RGB control and strobe channel for maximum effect usage	<ul style="list-style-type: none"> <li>• Quick dimming curve</li> <li>• Boost mode for maximum intensity</li> <li>• 5600K white point setting</li> </ul>

\*See user manual for complete list of features for each Quick Setup

**CONTROL OPTIONS**

**Studio HD**

**DMX Input Channel Profiles**

DMX Profile	DMX Channels	Channel Assignments	Notes
Studio	3	1 – Intensity 2 – Color Point (CCT) 3 – Tint	Controls fixture as a white light unit. If no DMX, i.e. console input, is present, fixture can be adjusted for these three parameters on the UI at the back of the unit.
Direct	9	1 – Red 2 – Orange (white if Lustr+) 3 – Amber 4 – Green 5 – 3000K White 6 – 5000K White 7 – Indigo 8 – Intensity 9 – Strobe	Direct control of each individual color with a separate master intensity channel. Color calibration of LEDs is not active in this mode. The nine-channel profile will produce the highest quality color cross-fades.
HSI	5	1 – Hue (coarse) 2 – Hue (fine) 3 – Saturation 4 – Intensity 5 – Strobe	High resolution hue (two-channels), saturation, and intensity control. HSI mode will produce color cross-fades around the color space.
HSIC	6	1 – Hue (coarse) 2 – Hue (fine) 3 – Saturation 4 – Intensity 5 – Strobe 6 – Color Point (CCT)	High-resolution hue, saturation and intensity control as above, with the addition of a color point channel to adjust the color temperature of the fixture in both white light and color. Color cross-fade performance is the same as HSI.
RGB	5 (Ch. 4 not used)	1 – Red 2 – Green 3 – Blue 4 – n/a 5 – Strobe	Effectively addresses all seven colors via three channels of control. RGB profile will produce medium quality color cross-fades

**Additional profile options**

Plus 7	Seven additional color control channels are available in RGB, HSI, HSIC, and Studio profile settings. For example HSI with ‘Plus 7’ enabled becomes a 14-channel profile:	1 – Hue (coarse) 2 – Hue (fine) 3 – Saturation 4 – Intensity 5 – Strobe 6 – n/a 7 – Plus 7 Control on/off 8 – Red 9 – Orange (white if Lustr+) 10 – Amber 11 – Green 12 – Cyan 13 – Blue 14 – Indigo	The desired color and intensity is achieved by using the HSI or RGB channels.  Placing channel seven at a value over 51% gives the fixture a 14-channel profile.  Channels 8-14 represent the native colors of the fixture and allow the operator to adjust individual color channels to fine tune the color output.
Strobe	Variable strobe control: 0% is no strobe. The fixture output will strobe more rapidly as the strobe channel value approaches 100%.		



CONTROL OPTIONS

**Studio Daylight and Studio Tungsten (only)**

**Quick Set-Ups**

Setting Title	Profile	Description	Typical Features
Studio	Studio	Enables control of intensity from luminaire UI; no console required	<ul style="list-style-type: none"> <li>• Linear dimming curve</li> <li>• Regulated output for intensity stability</li> </ul>
Single Channel	Direct	For general purpose architectural use	<ul style="list-style-type: none"> <li>• Standard dimming curve</li> <li>• Regulated output for consistency</li> </ul>
Stage	Direct	Matches conventional luminaire performance	<ul style="list-style-type: none"> <li>• Incandescent dimming curve</li> <li>• Regulated output</li> </ul>

**DMX Input Channel Profiles**

DMX Profile	DMX Channels	Channel Assignments	Notes
Studio	3	1 – Intensity 2 – Strobe 3 – Fan Control (D60 only)	Control of parameters is also enabled from the luminaire's user interface. No console required.
Direct	3	1 – Intensity 2 – Strobe 3 – Fan Control (D60 only)	

PHOTOMETRICS

**D40XT Studio HD™**

Mode	Degree	Candela	Field Lumens	Beam Lumens	Lumens Per Watt
Boost - Cold	17°	121,900	3,120	1,410	30.9
Regulated	17°	109,500	2,780	1,260	30.9

Metric conversions: For meters, multiply feet by 0.3048  
 For lux, multiply footcandles by 10.76

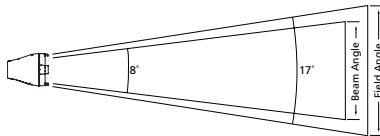

Throw Distance (d)	10.0'	15.0'	20.0'	25.0'	349'
	3.0m	4.6m	6.1m	7.6m	106m
Field Diameter	3.1'	4.7'	6.3'	7.8'	-
	1.0m	1.4m	1.9m	2.4m	-
Illuminance (fc)	1,219	542	305	195	1
Illuminance (lux)	13,121	5,832	3,280	2,099	10.76

To determine center beam illumination in footcandles at any throw distance, divide candela by the throw distance squared

For field diameter at any distance, multiply distance by 0.313  
 For beam diameter at any distance, multiply by 0.143

**Cosine Candela Plot**

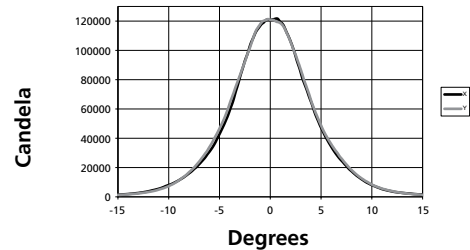

**Iso-Illuminance Diagram (Flat Surface Distribution)**

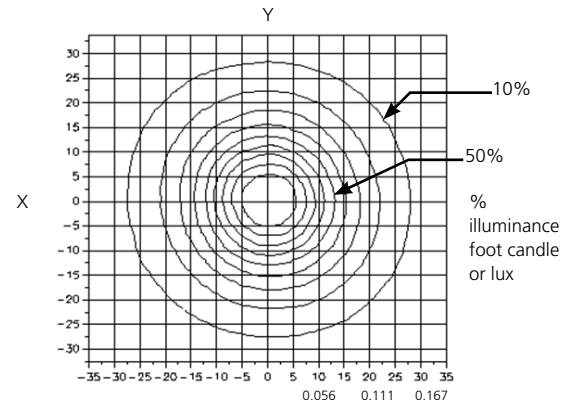

**D40XT Studio Daylight™**

Mode	Degree	Candela	Field Lumens	Beam Lumens	Lumens Per Watt
Boost - Cold	22°	125,700	5,380	2,850	52.5
Regulated	22°	125,350	3,440	1,820	56.3

Metric conversions: For meters, multiply feet by 0.3048  
 For lux, multiply footcandles by 10.76

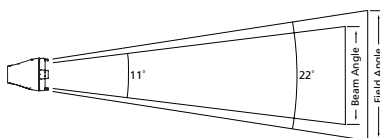

Throw Distance (d)	10'	15'	20'	25'	354'
	3.0m	4.6m	6.1m	7.6m	108.1m
Field Diameter	3.9'	5.8'	7.8'	9.7'	-
	1.2m	1.8m	2.4m	3.0m	-
Illuminance (fc)	1,257	559	314	201	1
Illuminance (lux)	13,530	6,013	3,383	2,165	10.76

To determine center beam illumination in footcandles at any throw distance, divide candela by the throw distance squared

For field diameter at any distance, multiply distance by 0.390  
 For beam diameter at any distance, multiply by 0.198

**Cosine Candela Plot**

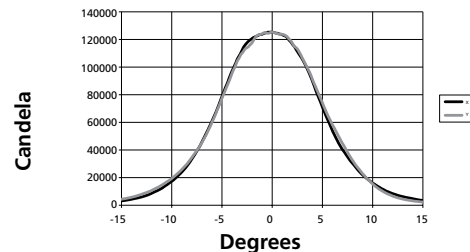

**Iso-Illuminance Diagram (Flat Surface Distribution)**

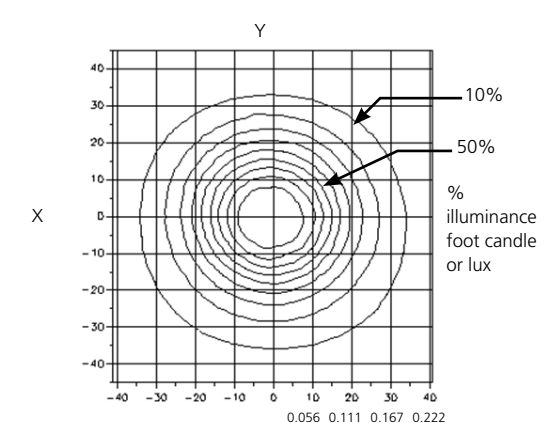

PHOTOMETRICS

**D40XT Studio Tungsten™**

Mode	Degree	Candela	Field Lumens	Beam Lumens	Lumens Per Watt
Boost - Cold	24°	9,030	4,105	1,900	40.0
Regulated	24°	79,720	3,514	1,620	36.9

Metric onversions: For meters, multiply feet by 0.3048  
 For lux, multiply footcandles by 10.76

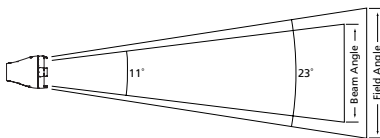

Throw Distance (d)	10'	15'	20'	25'	305'
	3.0m	4.6m	6.1m	7.6m	93m
Field Diameter	4.1'	6.2'	8.3'	10.4'	-
	1.3m	1.9m	2.5m	3.2m	-
Illuminance (fc)	930	413	233	149	1
Illuminance (lux)	10,014	4,451	2,503	1,602	10.76

For field diameter at any distance, multiply distance by 0.414  
 For beam diameter at any distance, multiply by 0.189

Throw Distance Multiplier (TDM)

To determine the distance from the center of the beam (Origin) to a certain illuminance level at a particular distance, multiply the desired throw distance by the TDM desired on the Iso-Illuminance diagram.

Throw Distance (TD) x Throw Distance Multiplier (TDM) = Distance from the Origin (DfO) (distance from the center of the beam)

Example: 25 feet (TD) x 0.047 (TDM) = 1.175 feet from center of beam (DfO)

For illumination with any lamp, multiply the candlepower of a beam spread by the multiplying factor (mf) shown for that lamp.

To determine illumination in footcandles or lux at any throw distance, divide candlepower by distance squared.

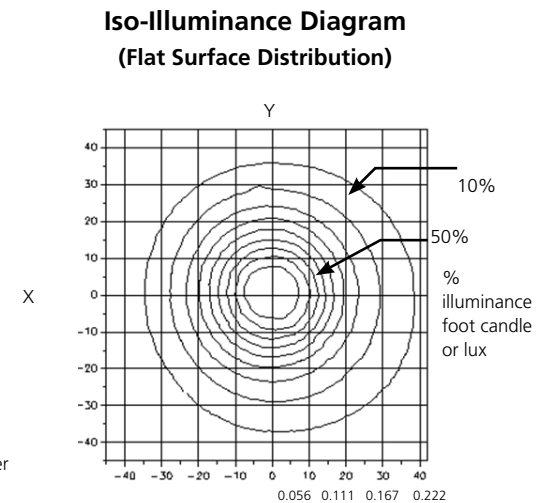
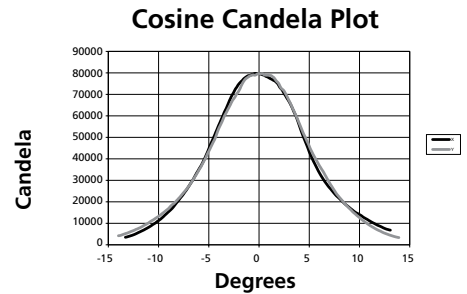

PHYSICAL

**Selador D40XT Studio Weights and Dimensions**

WEIGHT*		SHIPPING WEIGHT	
lbs	kgs	lbs	kgs
14	6.4	17	7.8

\* Does not include mounting hardware

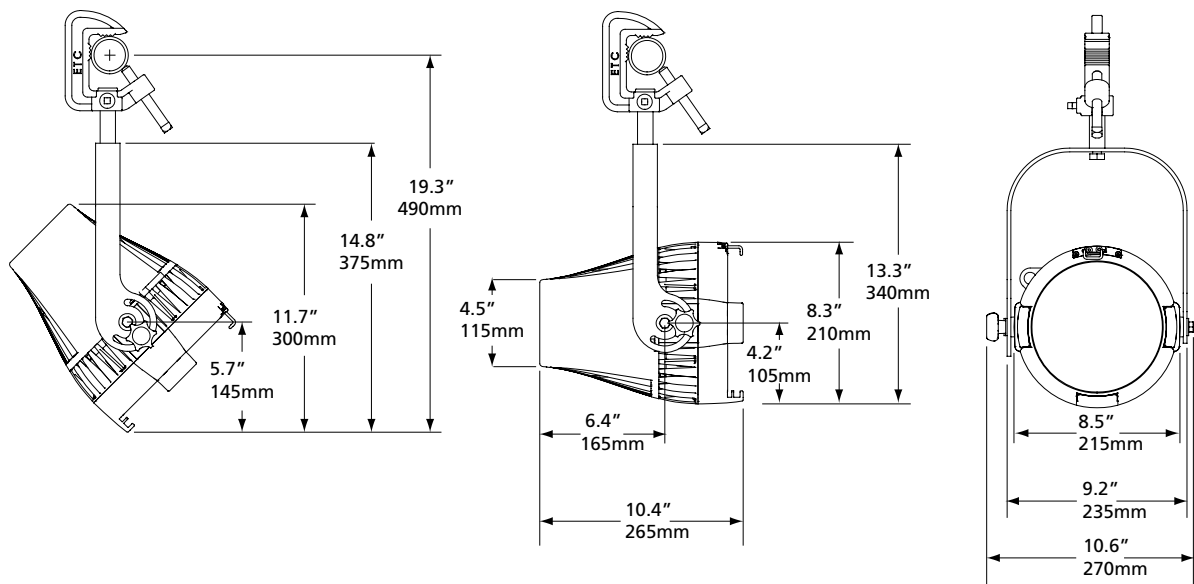

Note: D40XT Studio fixtures are equipped with attached 39" power and data leads



**Corporate Headquarters** • 3031 Pleasant View Rd, PO Box 620979, Middleton WI 53562 0979 USA • Tel +1 608 831 4116 • Fax +1 608 836 1736  
**London, UK** • Unit 26-28, Victoria Industrial Estate, Victoria Road, London W3 6UU, UK • Tel +44 (0)20 8896 1000 • Fax +44 (0)20 8896 2000  
**Rome, IT** • Via Pieve Torina, 48, 00156 Rome, Italy • Tel +39 (06) 32 111 683 • Fax +44 (0)20 8752 8486  
**Holzkirchen, DE** • Ohmstrasse 3, 83607 Holzkirchen, Germany • Tel +49 (80 24) 47 00-0 • Fax +49 (80 24) 47 00-3 00  
**Hong Kong** • Room 1801, 18/F, Tower 1 Phase 1, Enterprise Square, 9 Sheung Yuet Road, Kowloon Bay, Kowloon, Hong Kong • Tel +852 2799 1220 • Fax +852 2799 9325  
**Web** • www.etconnect.com • Copyright©2016 ETC. All Rights Reserved. All product information and specifications subject to change. 7410L1004 Rev. O USA 03/16

This product is protected by one or more of the following U.S. Patents: 6,016,038, 6,150,774, 6,788,011, 6,806,659, 6,683,423 and 7,023,543

# See Schedule for Ordering Info

# Canal Plaza

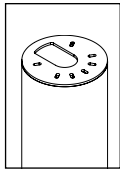

## ADJUSTABLE WELL STAR™

<b>PROJECT:</b>	
<b>TYPE:</b>	
<b>CATALOG NUMBER:</b>	
<b>SOURCE:</b>	
<b>NOTES:</b>	

### CATALOG NUMBER LOGIC

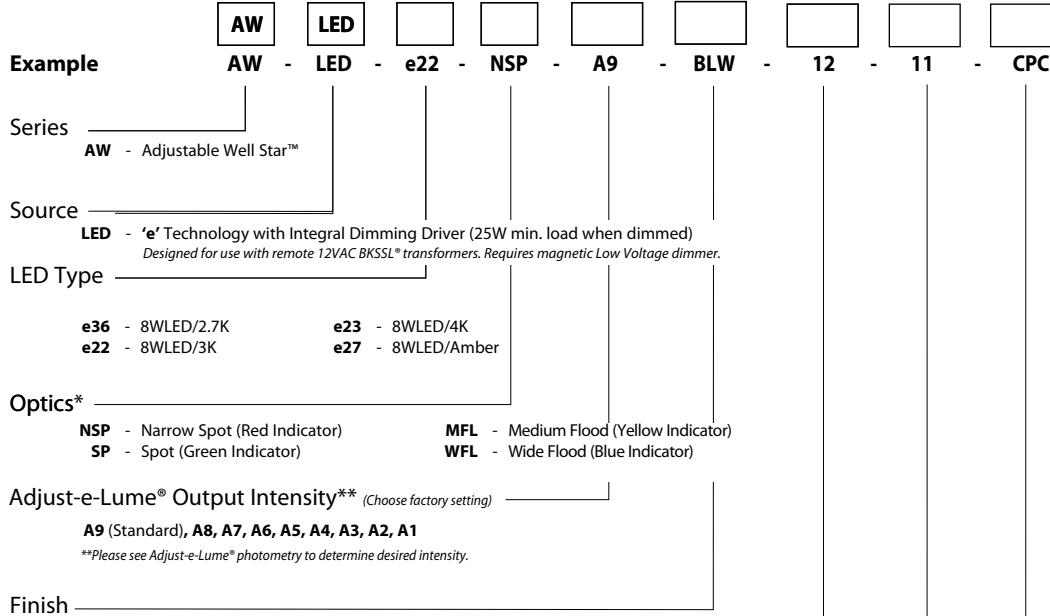

#### Cast Brass Finish

Machined	<b>MAC</b>
Polished	<b>POL</b>
Mitique	<b>MIT</b>
<b>Powder Coat Color</b>	<b>Wrinkle</b>
Bronze	<b>BZW</b>
Black	<b>BLW</b>
White (Gloss)	<b>WHW</b>
Verde	<b>VER</b>

#### Premium Finish

<b>ABP</b> Antique Brass Powder	<b>CMG</b> Cascade Mountain Granite	<b>RMG</b> Rocky Mountain Granite
<b>AMG</b> Aleutian Mountain Granite	<b>CRI</b> Cracked Ice	<b>SDS</b> Sonoran Desert Sandstone
<b>AQW</b> Antique White	<b>CRM</b> Cream	<b>SMG</b> Sierra Mountain Granite
<b>BCM</b> Black Chrome	<b>HUG</b> Hunter Green	<b>TXF</b> Textured Forest
<b>BGE</b> Beige	<b>MDS</b> Mojave Desert Sandstone	<b>WCP</b> Weathered Copper
<b>BPP</b> Brown Patina Powder	<b>NBP</b> Natural Brass Powder	<b>WIR</b> Weathered Iron
<b>CAP</b> Clear Anodized Powder	<b>OCP</b> Old Copper	<i>Also available in RAL Finishes See submittal SUB-1439-00</i>

Lens **12** - Soft Focus Lens      **13** - Rectilinear Lens

Shielding **11** - Honeycomb Baffle

Options **CPC** - Concrete Pour Collar (Must be factory installed)

### DRIVER DATA

<b>Input Volts</b> 12VAC/DC 50/60Hz	<b>InRush Current</b> <1A (non-dimmed)	<b>Dimmable</b> Magnetic Low Voltage Dimmer	<b>Operation Ambient Temperature</b> -10°F-130°F
--	---	--	---

### LM79 DATA

BK No.	CCT (Typ.)	Input Watts (Typ.)	CRI (Typ.)
e36	2700K	8.4	90
e22	3100K	8.4	90
e23	4100K	8.4	75
e27	Amber (590nm)	7.9	~

### L70 DATA

Minimum Rated Life (hrs.) 70% of initial lumens (L70)
50,000
50,000
50,000
50,000

### \*OPTICAL DATA

Beam Type	Angle	Visual Indicator
Narrow Spot	14°	Red Dot
Spot	18°	Green Dot
Medium Flood	25°	Yellow Dot
Wide Flood	36°	Blue Dot

<b>B-K LIGHTING</b>	40429 Brickyard Drive • Madera, CA 93636 • USA 559.438.5800 • FAX 559.438.5900 www.bklighting.com • info@bklighting.com	RELEASED 07-10-15	DRAWING NUMBER SUB000967
	THIS DOCUMENT CONTAINS PROPRIETARY INFORMATION OF B-K LIGHTING, INC. AND ITS RECEIPT OR POSSESSION DOES NOT CONVEY ANY RIGHTS TO REPRODUCE, DISCLOSE ITS CONTENTS, OR TO MANUFACTURE, USE OR SELL ANYTHING IT MAY DESCRIBE. REPRODUCTION, DISCLOSURE OR USE WITHOUT SPECIFIC WRITTEN AUTHORIZATION OF B-K LIGHTING, INC. IS STRICTLY FORBIDDEN.		

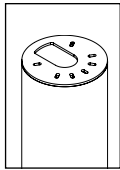

**BKSSL**  
SOLID STATE LIGHTING

the power of  
dimming with **adjust-e-Lume**<sup>®</sup>  
TECHNOLOGY

## ADJUSTABLE WELL STAR™

PROJECT:

TYPE:

**SIDE VIEW**

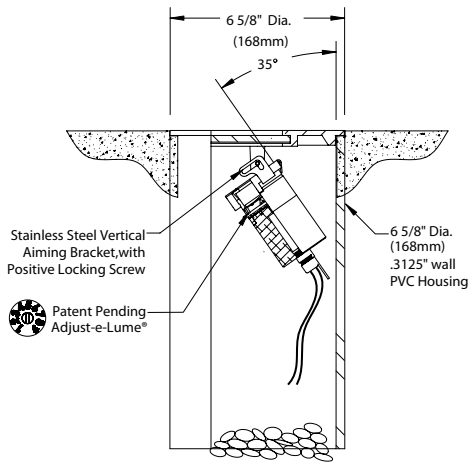

**FACEPLATE DETAIL**

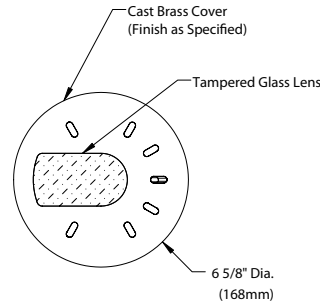

**FACEPLATE W/OPTIONAL CPC**

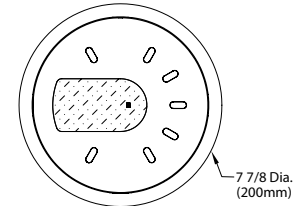

**SIDE VIEW WITH CPC**

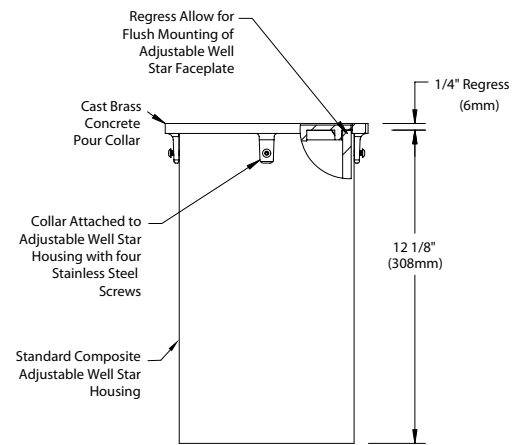

All dimensions indicated on this submittal are nominal. Contact Technical Sales if you require more stringent specifications.

### Accessories (Configure separately)

#### Remote options:



TR Series



UPMRM™

## SPECIFICATIONS

### GreenSource Initiative™

Metal and packaging components are made from recycled materials. Manufactured using renewable solar energy, produced on site. Returnable to manufacturer at end of life to ensure cradle-to-cradle handling. Packaging contains no chlorofluorocarbons (CFC's). Use of this product may qualify for GreenSource efficacy and recycling rebate(s). Consult [www.bklighting.com/greensource](http://www.bklighting.com/greensource) for program requirements.

### Materials

Furnished in Brass (Type 360).

### Well Cover

Cast construction. Slotted, flow through design. (3) Visually concealed set screws for faceplate installation. Shock resistant, tempered secondary glass lens.

### Body

Fully machined from solid billet. Unibody design provides enclosed, water-proof wireway and integral heat sink for maximum component life. High temperature, silicone 'O' Ring provides water-tight seal. Provided with hard-coat (Type III) black anodize finish for maximum corrosion resistance. Weather-tight cable connector with 5'0," 12Ga., 2 wire low voltage cable.

### Cap

Fully machined. Accommodates [1] lens or louver media. Flush lens.

### Lens

Shock resistant, tempered, primary glass lens is factory adhered to cap and provides hermetically sealed optical compartment. Specify soft focus (#12) or rectilinear (#13) lens.

### BKSSL®

Integrated solid state system with 'e' technology is scalable for field upgrade. Modular design with electrical quick disconnects permit field maintenance. High power, forward throw source complies with ANSI C78.377 binning requirements. Exceeds ENERGY STAR® lumen maintenance requirements. LM-80 certified components.

Integral, constant current driver. 12VAC/VDC input. 50/60Hz. Proprietary input control scheme achieves power factor correction and eliminates inrush current. Output, over-voltage, open-circuit, and short circuit protected. Inrush current limited to <1A (non-dimming). Conforms to Safety Std. C22.2 No. 250.13-12.

Line dimmable. For use with low voltage dimmer with dedicated neutral conductor. Minimum 25 watt load required for dimming.

### Adjust-e-Lume® (Pat. Pending)

Integral electronics allows dynamic lumen response at the individual fixture. Indexed (100% to 25% nom.) lumen output. Maintains output at desired level or may be changed as conditions require. Specify factory preset output intensity.

### Optics

Interchangeable OPTIKIT™ modules permit field changes to optical distribution. Color-coded for easy reference: Narrow Spot (NSP) = Red. Spot (SP) = Green. Medium Flood (MFL) = Yellow. Wide Flood (WFL) = Blue.

### Installation

6-5/8" dia., heavy wall composite housing for direct burial into soil or concrete. Flow through design for drainage (drain material by others). Optional concrete pour collar for flush installation with finished grade. Stainless steel vertical aiming bracket with positive locking screw permits up to 35° vertical adjustment from nadir. Biaxial source control with 360° horizontal rotation in addition to vertical adjustment.

For direct burial in soil or concrete. Consult Drainage Installation Guide for In-Grade Fixtures (DIG-IT) for compliance with proper soil preparation and drainage requirements prior to installation.

### Transformer

For use with 12VAC BKSSL remote transformer or magnetic transformers only. B-K Lighting cannot guarantee performance with third party manufacturers' transformers.

### Wiring

Teflon® coated, 18AWG, 600V, 250° C rated and certified to UL 1659 standard. Anti-Siphon Valve (ASV™) prevents "wicking" through conductor insulation.

### Hardware

Tamper-resistant, stainless steel hardware.

### Finish

Brass components are available in Class 'A' TGIC polyester powder coat or handcrafted metal finish.

### Warranty

5 year limited warranty.

### Certification and Listing

ITL tested to IESNA LM-79. Lighting Facts Registration per USDOE ([www.lightingfacts.com](http://www.lightingfacts.com)). ETL Listed to ANSI/UL Standard 1838 and UL Subject 8750 and Certified to CAN/CSA Standard C22.2 No. 9. RoHS compliant. Suitable for use in wet locations. Suitable for ground-mounted recessed. IP66 Rated. Made in USA.



\*Teflon is a registered trademark of DuPont Corporation.  
\*Energy Star is a registered trademark of the United States Environmental Protection Agency.

**B-K LIGHTING**

40429 Brickyard Drive • Madera, CA 93636 • USA  
559.438.5800 • FAX 559.438.5900  
[www.bklighting.com](http://www.bklighting.com) • [info@bklighting.com](mailto:info@bklighting.com)

RELEASED  
07-10-15

DRAWING NUMBER  
SUB000967

**Greg Day Lighting**

**Type G**

# See Schedule for Ordering Info

# Canal Plaza

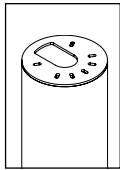

## ADJUSTABLE WELL STAR™

<b>PROJECT:</b>	
<b>TYPE:</b>	
<b>CATALOG NUMBER:</b>	
<b>SOURCE:</b>	
<b>NOTES:</b>	

### CATALOG NUMBER LOGIC

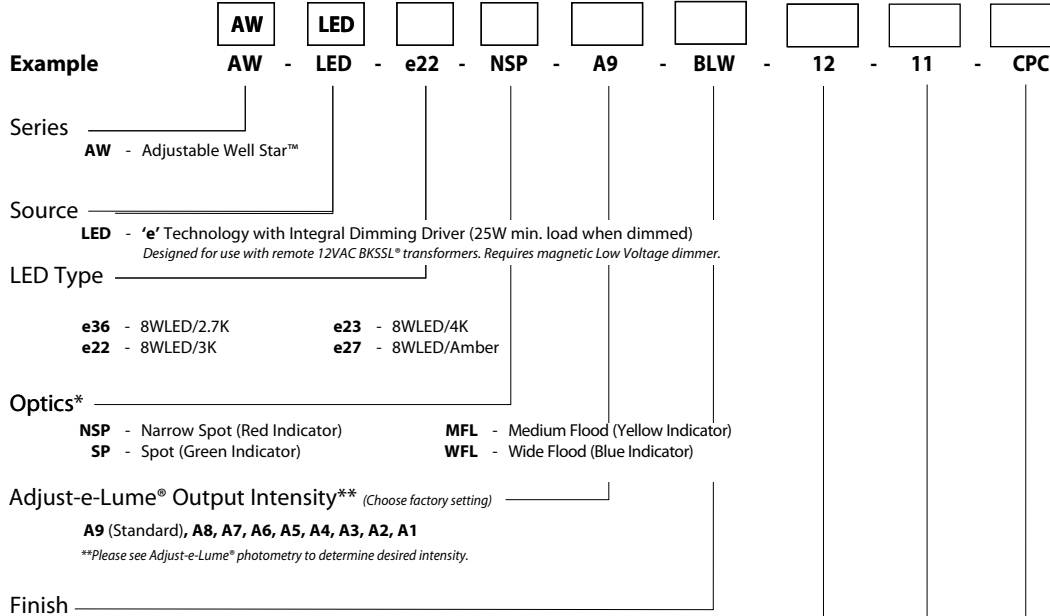

#### Cast Brass Finish

Machined	<b>MAC</b>
Polished	<b>POL</b>
Mitique	<b>MIT</b>
<b>Powder Coat Color</b>	<b>Wrinkle</b>
Bronze	<b>BZW</b>
Black	<b>BLW</b>
White (Gloss)	<b>WHW</b>
Verde	<b>VER</b>

#### Premium Finish

<b>ABP</b> Antique Brass Powder	<b>CMG</b> Cascade Mountain Granite	<b>RMG</b> Rocky Mountain Granite
<b>AMG</b> Aleutian Mountain Granite	<b>CRI</b> Cracked Ice	<b>SDS</b> Sonoran Desert Sandstone
<b>AQW</b> Antique White	<b>CRM</b> Cream	<b>SMG</b> Sierra Mountain Granite
<b>BCM</b> Black Chrome	<b>HUG</b> Hunter Green	<b>TXF</b> Textured Forest
<b>BGE</b> Beige	<b>MDS</b> Mojave Desert Sandstone	<b>WCP</b> Weathered Copper
<b>BPP</b> Brown Patina Powder	<b>NBP</b> Natural Brass Powder	<b>WIR</b> Weathered Iron
<b>CAP</b> Clear Anodized Powder	<b>OCP</b> Old Copper	<i>Also available in RAL Finishes See submittal SUB-1439-00</i>

Lens **12** - Soft Focus Lens      **13** - Rectilinear Lens

Shielding **11** - Honeycomb Baffle

Options **CPC** - Concrete Pour Collar (Must be factory installed)

#### DRIVER DATA

<b>Input Volts</b> 12VAC/DC 50/60Hz	<b>InRush Current</b> <1A (non-dimmed)	<b>Dimmable</b> Magnetic Low Voltage Dimmer	<b>Operation Ambient Temperature</b> -10°F-130°F
--	---	--	---

#### LM79 DATA

BK No.	CCT (Typ.)	Input Watts (Typ.)	CRI (Typ.)
e36	2700K	8.4	90
e22	3100K	8.4	90
e23	4100K	8.4	75
e27	Amber (590nm)	7.9	~

#### L70 DATA

Minimum Rated Life (hrs.) 70% of initial lumens (L70)
50,000
50,000
50,000
50,000

#### \*OPTICAL DATA

Beam Type	Angle	Visual Indicator
Narrow Spot	14°	Red Dot
Spot	18°	Green Dot
Medium Flood	25°	Yellow Dot
Wide Flood	36°	Blue Dot

<b>B-K LIGHTING</b>	40429 Brickyard Drive • Madera, CA 93636 • USA 559.438.5800 • FAX 559.438.5900 www.bklighting.com • info@bklighting.com	RELEASED 07-10-15	DRAWING NUMBER SUB000967
	THIS DOCUMENT CONTAINS PROPRIETARY INFORMATION OF B-K LIGHTING, INC. AND ITS RECEIPT OR POSSESSION DOES NOT CONVEY ANY RIGHTS TO REPRODUCE, DISCLOSE ITS CONTENTS, OR TO MANUFACTURE, USE OR SELL ANYTHING IT MAY DESCRIBE. REPRODUCTION, DISCLOSURE OR USE WITHOUT SPECIFIC WRITTEN AUTHORIZATION OF B-K LIGHTING, INC. IS STRICTLY FORBIDDEN.		

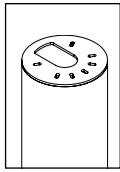

**BKSSL**  
SOLID STATE LIGHTING

the power of  
dimming with **adjust-e-Lume**<sup>®</sup>  
TECHNOLOGY

## ADJUSTABLE WELL STAR™

PROJECT:

TYPE:

### SIDE VIEW

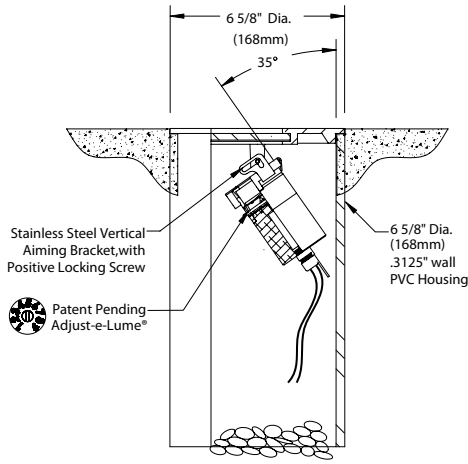

### FACEPLATE DETAIL

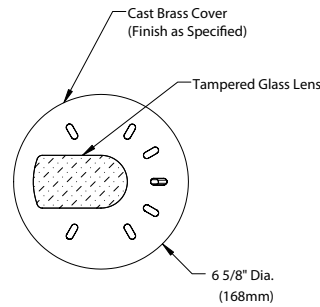

### FACEPLATE W/OPTIONAL CPC

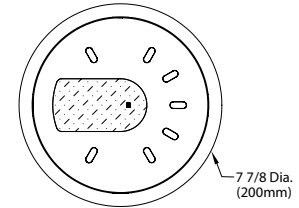

### SIDE VIEW WITH CPC

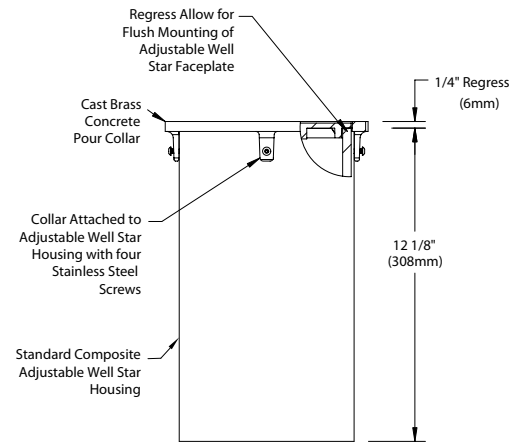

All dimensions indicated on this submittal are nominal. Contact Technical Sales if you require more stringent specifications.

### Accessories (Configure separately)

#### Remote options:



TR Series

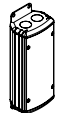

UPMRM™

## SPECIFICATIONS

### GreenSource Initiative™

Metal and packaging components are made from recycled materials. Manufactured using renewable solar energy, produced on site. Returnable to manufacturer at end of life to ensure cradle-to-cradle handling. Packaging contains no chlorofluorocarbons (CFC's). Use of this product may qualify for GreenSource efficacy and recycling rebate(s). Consult [www.bklighting.com/greensource](http://www.bklighting.com/greensource) for program requirements.

### Materials

Furnished in Brass (Type 360).

### Well Cover

Cast construction. Slotted, flow through design. (3) Visually concealed set screws for faceplate installation. Shock resistant, tempered secondary glass lens.

### Body

Fully machined from solid billet. Unibody design provides enclosed, water-proof wireway and integral heat sink for maximum component life. High temperature, silicone 'O' Ring provides water-tight seal. Provided with hard-coat (Type III) black anodize finish for maximum corrosion resistance. Weather-tight cable connector with 5'0," 12Ga., 2 wire low voltage cable.

### Cap

Fully machined. Accommodates [1] lens or louver media. Flush lens.

### Lens

Shock resistant, tempered, primary glass lens is factory adhered to cap and provides hermetically sealed optical compartment. Specify soft focus (#12) or rectilinear (#13) lens.

### BKSSL®

Integrated solid state system with 'e' technology is scalable for field upgrade. Modular design with electrical quick disconnects permit field maintenance. High power, forward throw source complies with ANSI C78.377 binning requirements. Exceeds ENERGY STAR® lumen maintenance requirements. LM-80 certified components.

Integral, constant current driver. 12VAC/VDC input. 50/60Hz. Proprietary input control scheme achieves power factor correction and eliminates inrush current. Output, over-voltage, open-circuit, and short circuit protected. Inrush current limited to <1A (non-dimming). Conforms to Safety Std. C22.2 No. 250.13-12.

Line dimmable. For use with low voltage dimmer with dedicated neutral conductor. Minimum 25 watt load required for dimming.

### Adjust-e-Lume® (Pat. Pending)

Integral electronics allows dynamic lumen response at the individual fixture. Indexed (100% to 25% nom.) lumen output. Maintains output at desired level or may be changed as conditions require. Specify factory preset output intensity.

### Optics

Interchangeable OPTIKIT™ modules permit field changes to optical distribution. Color-coded for easy reference: Narrow Spot (NSP) = Red. Spot (SP) = Green. Medium Flood (MFL) = Yellow. Wide Flood (WFL) = Blue.

### Installation

6-5/8" dia., heavy wall composite housing for direct burial into soil or concrete. Flow through design for drainage (drain material by others). Optional concrete pour collar for flush installation with finished grade. Stainless steel vertical aiming bracket with positive locking screw permits up to 35° vertical adjustment from nadir. Biaxial source control with 360° horizontal rotation in addition to vertical adjustment.

For direct burial in soil or concrete. Consult Drainage Installation Guide for In-Grade Fixtures (DIG-IT) for compliance with proper soil preparation and drainage requirements prior to installation.

### Transformer

For use with 12VAC BKSSL remote transformer or magnetic transformers only. B-K Lighting cannot guarantee performance with third party manufacturers' transformers.

### Wiring

Teflon® coated, 18AWG, 600V, 250° C rated and certified to UL 1659 standard. Anti-Siphon Valve (ASV™) prevents "wicking" through conductor insulation.

### Hardware

Tamper-resistant, stainless steel hardware.

### Finish

Brass components are available in Class 'A' TGIC polyester powder coat or handcrafted metal finish.

### Warranty

5 year limited warranty.

### Certification and Listing

ITL tested to IESNA LM-79. Lighting Facts Registration per USDOE ([www.lightingfacts.com](http://www.lightingfacts.com)). ETL Listed to ANSI/UL Standard 1838 and UL Subject 8750 and Certified to CAN/CSA Standard C22.2 No. 9. RoHS compliant. Suitable for use in wet locations. Suitable for ground-mounted recessed. IP66 Rated. Made in USA.



\*Teflon is a registered trademark of DuPont Corporation.  
\*Energy Star is a registered trademark of the United States Environmental Protection Agency.

**B-K LIGHTING**

40429 Brickyard Drive • Madera, CA 93636 • USA  
559.438.5800 • FAX 559.438.5900  
[www.bklighting.com](http://www.bklighting.com) • [info@bklighting.com](mailto:info@bklighting.com)

RELEASED  
07-10-15

DRAWING NUMBER  
SUB000967

**Greg Day Lighting**

**Type G1**





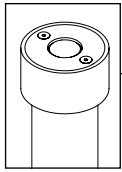

the power of

## MINI-MICRO™ RECESSED UPLIGHT



PROJECT:	
TYPE:	

### FLUSH MOUNT

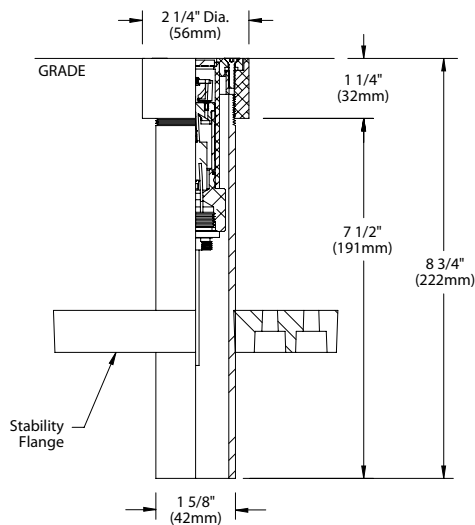
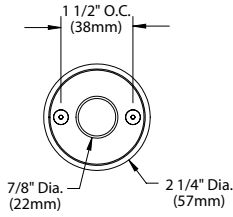

### SURFACE MOUNT

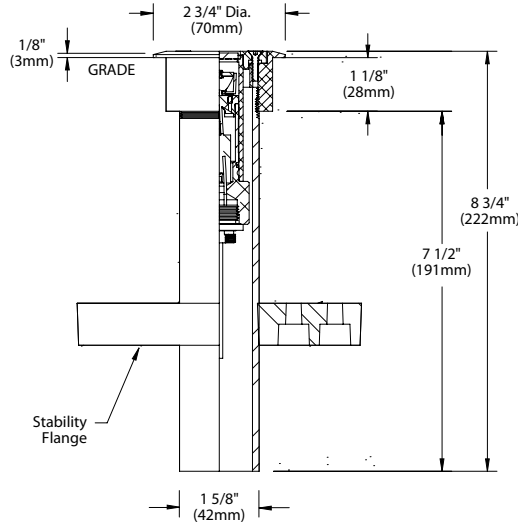
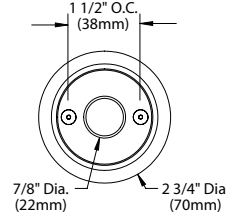

### STABILITY FLANGE

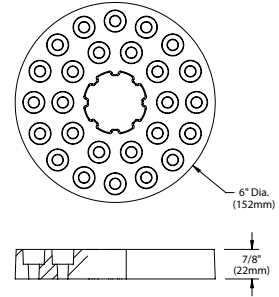

All dimensions indicated on this submittal are nominal. Contact Technical Sales if you require more stringent specifications.

## SPECIFICATIONS

### GreenSource Initiative™

Metal and packaging components are made from recycled materials. Manufactured using renewable solar energy, produced on site. Returnable to manufacturer at end of life to ensure cradle-to-cradle handling. Packaging contains no chlorofluorocarbons (CFC's). Use of this product may qualify for GreenSource efficacy and recycling rebate(s). Consult [www.bklighting.com/greensource](http://www.bklighting.com/greensource) for program requirements.

### Materials

Furnished in Copper-Free Aluminum (Type 6061-T6), Brass (Type 360) or Stainless Steel (Type 304).

### Body

Fully machined from solid billet. Unibody design provides enclosed, water-proof wireway and integral heat sink for maximum component life. High temperature, silicone 'O' Ring provides water-tight seal. Provided with hard-coat (Type III) black anodize finish for maximum corrosion resistance. Weather-tight cable connector with 5' 18Ga, 2 wire low voltage cable.

### Housing

Fixture provided with 1-5/8" dia., Schedule 80 PVC housing for direct burial into soil or concrete. 6" dia., molded stability flange projects into substrate to simplify installation and reinforce housing stability. Integral concrete pour collar for flush installation with finished grade. Collar material and finish to match faceplate. (2) Threaded holes for faceplate installation.

### Faceplate

Fully machined from solid billet. Countersunk holes provide for flush hardware mounting. Accommodates [1] lens or louver media.

### Lens

Shock resistant, tempered, glass lens is factory adhered to faceplate and provides hermetically sealed optical compartment. Specify soft focus (#12) or rectilinear (#13) lens.

### BKSSL®

Integrated solid state system with 'e' technology. High power, forward throw source complies with ANSI C78.377 binning requirements. Exceeds ENERGY STAR® lumen maintenance requirements. LM-80 certified components.

Integral non-dimming driver. Minimum 50,000 hour rated life at 70% of initial lumens (L70). BKSSL technology provides long life, significant energy reduction and exceptional thermal management.

### Optics

OPTIKIT™ modules are color-coded for easy reference: Narrow Spot (NSP) = Red, Spot (SP) = Green. Medium Flood (MFL) = Yellow and Asymmetrical (ASY) = Purple.

### Installation

Flush Mount features integral concrete pour collar. Top edge of collar to be installed flush with finished grade. Collar material and finish to match faceplate. (2) Threaded holes for faceplate installation. Faceplate is suitable for walk-over and drive-over applications to 35,000 lbs. GWV.

Surface Mount features fully machined copper-free aluminum installation collar. Collar material and finish to match faceplate. (2) Threaded holes for faceplate installation.

### Remote Transformer

For use with 12VAC BKSSL remote transformer or magnetic transformers only. B-K Lighting cannot guarantee performance with third party manufacturers' transformers.

### Wiring

PVC coated, 18AWG, 150V, 60°C rated and certified to UL 1838 standard. Anti-Siphon Valve (ASV™) prevents "wicking" through conductor insulation.

### Hardware

Tamper-resistant, stainless steel hardware. Faceplate screws are additionally black oxide treated for additional corrosion resistance.

### Finish

StarGuard®, our exclusive RoHs compliant, 15 stage chromate-free process cleans and conversion coats aluminum components prior to application of Class 'A' TGIC polyester powder coating. Brass components are available in powder coat or handcrafted metal finish. Stainless steel components are available in handcrafted metal finish. (Brushed finish for interior use only).

### Warranty

5 year limited warranty.

### Certification and Listing

ITL tested to IESNA LM-79. UL Listed. Certified to CAN/CSA/ANSI Standards. RoHs compliant. Suitable for use in wet locations. Suitable for walk-over and drive-over applications to 35,000 lbs. GWV. Suitable for ground-mounted recessed. IP66 Rated. Made in USA.



\*Energy Star is a registered trademark of the United States Environmental Protection Agency.

<b>B-K LIGHTING</b>	40429 Brickyard Drive • Madera, CA 93636 • USA	RELEASED	DRAWING NUMBER
	559.438.5800 • FAX 559.438.5900	01-29-16	SUB000933
www.bklighting.com • info@bklighting.com			

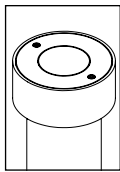

**BKSSL**  
SOLID STATE LIGHTING



# CANAL PLAZA ARTISTAR™ RECESSED UPLIGHT

PROJECT:	
TYPE:	
CATALOG NUMBER:	
SOURCE:	
NOTES:	

## CATALOG NUMBER LOGIC

Example S - UL - F - AR - LED - e64 - NSP - A6 - BLW - 12 - 11

### Material

- Blank** - Aluminum
- B** - Brass
- S** - Stainless Steel

### Series

- UL** - Recessed Uplight

### Installation

- F** - Flush mount
- S** - Surface mount

### Fixture

- AR** - ArtiStar™

### Source

- LED** - 'e' Technology with Integral Dimming Driver (25W min. load when dimmed).  
*Designed for use with remote 12VAC BKSSL® transformers. Requires magnetic Low Voltage dimmer.*

### LED Type

- e64** - 7WLED/2.7K
- e65** - 7WLED/3K
- e66** - 7WLED/4K
- e74** - 7WLED/Amber

### Optics\*

- NSP** - Narrow Spot (Red Indicator)
- SP** - Spot (Green Indicator)
- MFL** - Medium Flood (Yellow Indicator)
- WFL** - Wide Flood (Blue Indicator)

### Adjust-e-Lume® Output Intensity (Choose factory setting)

- A9** (Standard), **A8, A7, A6, A5, A4, A3, A2, A1**

### Finish

#### Aluminum Finish

Powder Coat Color	Satin	Wrinkle
Bronze	<b>BZP</b>	<b>BZW</b>
Black	<b>BLP</b>	<b>BLW</b>
White (Gloss)	<b>WHP</b>	<b>WHW</b>
Aluminum	<b>SAP</b>	—
Verde	—	<b>VER</b>

#### Brass Finish

Machined	<b>MAC</b>
Polished	<b>POL</b>
Mitique™	<b>MIT</b>

#### Stainless Finish

Machined	<b>MAC</b>
Polished	<b>POL</b>
Brushed	<b>BRU</b> <small>Interior use only.</small>

#### Premium Finish

<b>ABP</b> Antique Brass Powder	<b>CMG</b> Cascade Mountain Granite	<b>RMG</b> Rocky Mountain Granite
<b>AMG</b> Aleutian Mountain Granite	<b>CRI</b> Cracked Ice	<b>SDS</b> Sonoran Desert Sandstone
<b>AQW</b> Antique White	<b>CRM</b> Cream	<b>SMG</b> Sierra Mountain Granite
<b>BCM</b> Black Chrome	<b>HUG</b> Hunter Green	<b>TXF</b> Textured Forest
<b>BGE</b> Beige	<b>MDS</b> Mojave Desert Sandstone	<b>WCP</b> Weathered Copper
<b>BPP</b> Brown Patina Powder	<b>NBP</b> Natural Brass Powder	<b>WIR</b> Weathered Iron
<b>CAP</b> Clear Anodized Powder	<b>OCP</b> Old Copper	<small>Also available in RAL Finishes See submittal SUB-1439-00</small>

### Lens

- 12** - Soft Focus Lens
- 13** - Rectilinear Lens

### Shielding

- 11** - Honeycomb Baffle

## DRIVER DATA

Input Volts	InRush Current	Operating Current	Dimmable	Operation Ambient Temperature
12VAC/DC 50/60Hz	250mA (non-dimmed)	700mA	Magnetic Low Voltage Dimmer	-22°F-194°F (-30°C - 90°C)

## LM79 DATA

BK No.	CCT (Typ.)	Input Watts (Typ.)	CRI (Typ.)
e64	2700K	7.0	80
e65	3000K	7.0	80
e66	4000K	7.0	80
e74	Amber (590nm)	7.0	~

## L70 DATA

Minimum Rated Life (hrs.) 70% of initial lumens(L70)
50,000
50,000
50,000
50,000

## \* OPTICAL DATA

Beam Type	Angle	e66 CBCP	Visual Indicator
Narrow Spot	13°	6889	Red Dot
Spot	15°	5225	Green Dot
Medium Flood	23°	1984	Yellow Dot
Wide Flood	31°	1300	Blue Dot

# B-K LIGHTING

40429 Brickyard Drive • Madera, CA 93636 • USA  
559.438.5800 • FAX 559.438.5900  
www.bklighting.com • info@bklighting.com

RELEASED  
03-01-16

DRAWING NUMBER  
SUB-2322-00

THIS DOCUMENT CONTAINS PROPRIETARY INFORMATION OF B-K LIGHTING, INC. AND ITS RECEIPT OR POSSESSION DOES NOT CONVEY ANY RIGHTS TO REPRODUCE, DISCLOSE ITS CONTENTS, OR TO MANUFACTURE, USE OR SELL ANYTHING IT MAY DESCRIBE. REPRODUCTION, DISCLOSURE OR USE WITHOUT SPECIFIC WRITTEN AUTHORIZATION OF B-K LIGHTING, INC. IS STRICTLY FORBIDDEN.

# GREG DAY Lighting

# TYPE G3

ARTISTAR™ RECESSED UPLIGHT

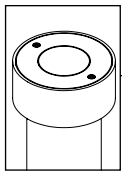

PROJECT:	
TYPE:	

FLUSH MOUNT

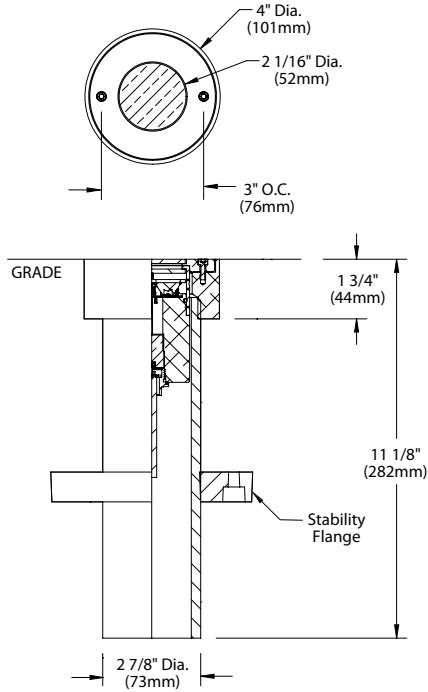

SURFACE MOUNT

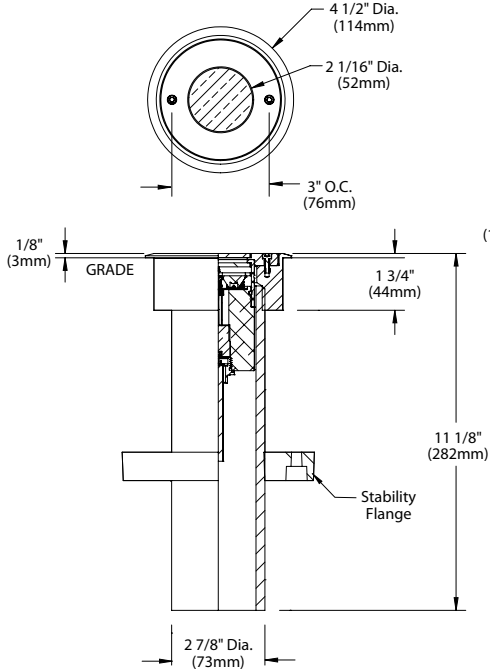

STABILITY FLANGE

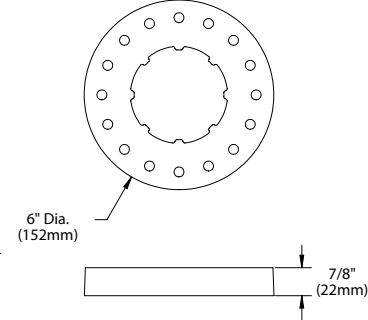

All dimensions indicated on this submittal are nominal. Contact Technical Sales if you require more stringent specifications.

SPECIFICATIONS

GreenSource Initiative™

Metal and packaging components are made from recycled materials. Manufactured using renewable solar energy, produced on site. Returnable to manufacturer at end of life to ensure cradle-to-cradle handling. Packaging contains no chlorofluorocarbons (CFC's). Use of this product may qualify for GreenSource efficacy and recycling rebate(s). Consult [www.bklighting.com/greensource](http://www.bklighting.com/greensource) for program requirements.

Materials

Furnished in Copper-Free Aluminum (Type 6061-T6), Brass (Type 360) or Stainless Steel (Type 304).

Body

Fully machined from solid billet. Unibody design provides enclosed, water-proof wireway and integral heat sink for maximum component life. Provided with hard-coat (Type III) black anodize finish for maximum corrosion resistance. Weather-tight cable connector with 5' 18Ga., 2 wire low voltage cable. High temperature, silicone 'O' Ring provides water-tight seal.

Housing

Fixture provided with 2-7/8" dia., Schedule 80 PVC housing for direct burial into soil or concrete. 6" dia., molded stability flange projects into substrate to simplify installation and reinforce housing stability.

Faceplate

Fully machined from solid billet. Countersunk holes provide for flush hardware mounting. Accommodates [1] lens or louver media.

Lens

Shock resistant, tempered, glass lens is factory adhered to fixture cap and provides hermetically sealed optical compartment. Specify soft focus (#12) or rectilinear (#13) lens.

BKSSL®

Integrated solid state system with 'e' technology is scalable for field upgrade. Modular design with electrical quick disconnects permit field maintenance. High power, forward throw source complies with ANSI C78.377 binning requirements. Exceeds ENERGY STAR® lumen maintenance requirements. LM-80 certified components.

Integral, constant current driver. 12VAC/VDC input. 50/60Hz. Proprietary input control scheme achieves power factor correction and eliminates inrush current. Output, over-voltage, open-circuit, and short circuit protected. Inrush current limited to <250mA (non-dimming). Conforms to Safety Std. C22.2 No. 250.13-12.

Line voltage dimmable via magnetic low voltage dimmer. For use with low voltage dimmer with dedicated neutral conductor. For purposes of dimming: Remote magnetic transformer with BKSSL® Power of 'e' technology loads should be loaded to 25% of the transformer VA (watts) rated value.

Adjust-e-Lume® (Pat. Pending)

Integral electronics allows dynamic lumen response at the individual fixture. Indexed (100% to 25% nom.) lumen output. Maintains output at desired level or may be changed as conditions require. Specify factory preset output intensity.

Optics

Interchangeable OPTIKIT™ modules permit field changes to optical distribution. Color-coded for easy reference: Narrow Spot (NSP) = Red. Spot (SP) = Green. Medium Flood (MFL) = Yellow. Wide Flood (WFL) = Blue.

Installation

Flush Mount features integral concrete pour collar. Top edge of collar to be installed flush with finished grade. Collar material and finish to match faceplate. (2) Threaded holes for faceplate installation. Faceplate is suitable for walk-over and drive-over applications to 35,000 lbs. GW.

Surface Mount features fully machined copper-free aluminum installation collar. Collar material and finish to match faceplate. (2) Threaded holes for faceplate installation.

Remote transformer

For use with 12VAC remote transformer or magnetic transformers only. B-K Lighting cannot guarantee performance with third party manufacturers' transformers.

Wiring

PVC coated, 18AWG, 150V, 60°C rated and certified to UL 1838 standard. Anti-Siphon Valve (ASV™) prevents "wicking" through conductor insulation.

Hardware

Tamper-resistant, stainless steel hardware. Faceplate screws are additionally black oxide treated for additional corrosion resistance.

Finish

StarGuard®, our exclusive RoHs compliant, 15 stage chromate-free process cleans and conversion coats aluminum components prior to application of Class 'A' TGIC polyester powder coating. Brass components are available in powder coat or handcrafted metal finish. Stainless steel components are available in handcrafted metal finish. (Brushed finish for interior use only).

Warranty

5 year limited warranty.

Certification and Listing





ITL tested to IESNA LM-79. UL Listed. Certified to CAN/CSA/ANSI Standards. RoHs compliant. Suitable for indoor or outdoor use. Suitable for use in wet locations. IP 66 Rated. Made in USA.



\*Energy Star is a registered trademark of the United States Environmental Protection Agency.

<p><b>B-K LIGHTING</b></p>	<p>40429 Brickyard Drive • Madera, CA 93636 • USA 559.438.5800 • FAX 559.438.5900 <a href="http://www.bklighting.com">www.bklighting.com</a> • <a href="mailto:info@bklighting.com">info@bklighting.com</a></p>	<p>RELEASED 03-01-16</p>	<p>DRAWING NUMBER SUB-2322-00</p>
	<p><b>GREG DAY Lighting</b></p>		

Select OptiKit™ for desired distribution

- RED**  **Narrow Spot (NSP)**
- GREEN**  **Spot (SP)**
- YELLOW**  **Medium Flood (MFL)**
- BLUE**  **Wide Flood (WFL)**

Set adjust-e-lume® Dial to desired output

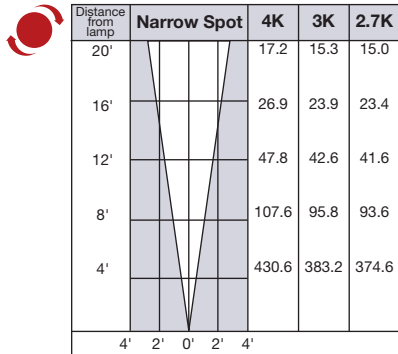

Note: If using No. 11 honeycomb baffle multiply footcandle values by .80

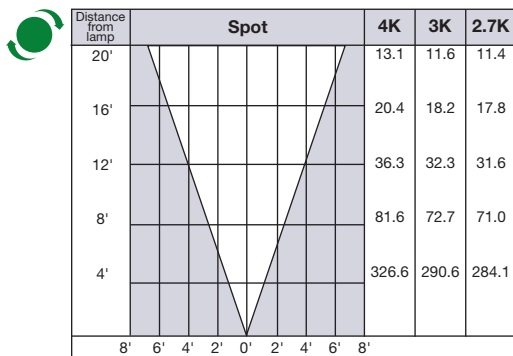

Note: If using No. 11 honeycomb baffle multiply footcandle values by .80

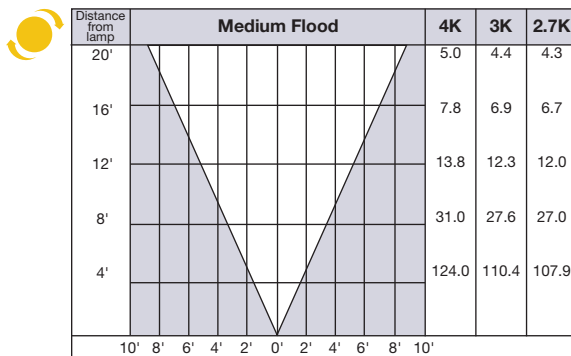

Note: If using No. 11 honeycomb baffle multiply footcandle values by .80

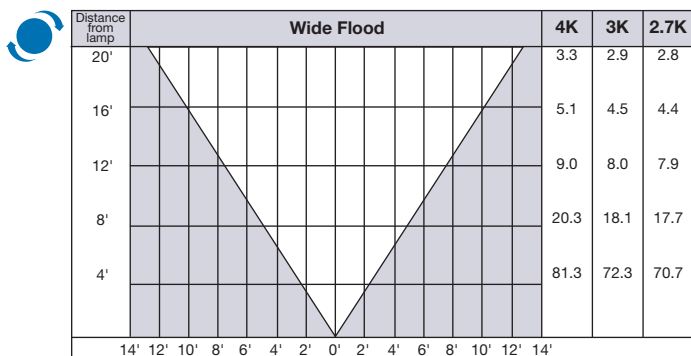

Note: If using No. 11 honeycomb baffle multiply footcandle values by .80

# See Schedule for Ordering Info

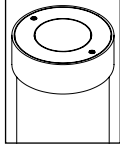

**BKSSL**  
SOLID STATE LIGHTING  
18-29W LED

THE POWER OF



# Canal Plaza DENALI™ RECESSED UPLIGHT

<b>PROJECT:</b>	
<b>TYPE:</b>	
<b>CATALOG NUMBER:</b>	
<b>SOURCE:</b>	
<b>NOTES:</b>	

## CATALOG NUMBER LOGIC



**Example**

**B - UL - S - DE - LED - x31 - FL - SAP - 10 - 11**

Material

- Blank** - Aluminum
- B** - Brass
- S** - Stainless Steel

Series

- UL** - Recessed Uplight

Installation

- F** - Flush mount
- S** - Surface mount

Fixture

- DE** - Denali Series™

Source

- LED** - 'X' Module with Cold Phosphor Technology

LED Type

- x30** - 18WLED/2.7K
- x31** - 18WLED/3K
- x32** - 18WLED/4K
- x33** - 29WLED/2.7K
- x34** - 29WLED/3K
- x35** - 29WLED/4K

Optics\*

- SP** - Spot (20°)
- FL** - Flood (40°)
- WFL** - Wide Flood (60°)

Finish

### Aluminum Finish

Powder Coat Color	Satin	Wrinkle
Bronze	<b>BZP</b>	<b>BZW</b>
Black	<b>BLP</b>	<b>BLW</b>
White (Gloss)	<b>WHP</b>	<b>WHW</b>
Aluminum	<b>SAP</b>	—
Verde	—	<b>VER</b>

### Brass Finish

Machined	<b>MAC</b>
Polished	<b>POL</b>
Mitique™	<b>MIT</b>

### Stainless Finish

Machined	<b>MAC</b>
Polished	<b>POL</b>
Brushed	<b>BRU</b> <small>Interior use only.</small>

### Premium Finish

<b>ABP</b> Antique Brass Powder	<b>CMG</b> Cascade Mountain Granite	<b>RMG</b> Rocky Mountain Granite
<b>AMG</b> Aleutian Mountain Granite	<b>CRI</b> Cracked Ice	<b>SDS</b> Sonoran Desert Sandstone
<b>AQW</b> Antique White	<b>CRM</b> Cream	<b>SMG</b> Sierra Mountain Granite
<b>BCM</b> Black Chrome	<b>HUG</b> Hunter Green	<b>TXF</b> Textured Forest
<b>BGE</b> Beige	<b>MDS</b> Mojave Desert Sandstone	<b>WCP</b> Weathered Copper
<b>BPP</b> Brown Patina Powder	<b>NBP</b> Natural Brass Powder	<b>WIR</b> Weathered Iron
<b>CAP</b> Clear Anodized Powder	<b>OCP</b> Old Copper	<i>Also available in RAL Finishes See submittal SUB-1439-00</i>

### Configure Driver Housing Separately Driver Housing Required

#### REMOTE DRIVER HOUSINGS:

- HP2RM** - HP2 Remote Housing
- PM2RM** - Universal Power Module 2 Remote
- PM2DRM** - Universal Power Module 2 Dual Remote
- RM** - Remote Wall Mount
- DRM** - Dual Remote Wall Mount

Lens

- 9** - Clear (Standard)
- 10** - Spread Lens
- 12** - Soft Focus Lens
- 13** - Rectilinear Lens

Shielding

- 11** - Honeycomb Baffle

\*Accommodates only 2 Lens/Shielding media

## LM79 DATA

BK No.	Lumens (Source)	CCT (Typ.)	CRI (Ra. Typ.)	Color Consistency	Input Watts (Typ.)
x30	1300	2700K	>80	±40K	18
x31	1300	3000K	>80	±50K	18
x32	1300	4000K	>80	±70K	18
x33	2000	2700K	>80	±40K	29
x34	2000	3000K	>80	±50K	29
x35	2000	4000K	>80	±70K	29

## L70 DATA

Minimum Rated Life (hrs.) 70% of initial lumens (L70)
50,000
50,000
50,000

## OPTICAL DATA

Beam Type	Angle	(x32) CBCP	(x35) CBCP
Spot	20°	2899	4222
Flood	40°	1270	1878
Wide Flood	60°	968	1450

# B-K LIGHTING

40429 Brickyard Drive • Madera, CA 93636 • USA  
559.438.5800 • FAX 559.438.5900  
www.bklighting.com • info@bklighting.com

RELEASED  
07-10-15

DRAWING NUMBER  
SUB-2323-00

THIS DOCUMENT CONTAINS PROPRIETARY INFORMATION OF B-K LIGHTING, INC. AND ITS RECEIPT OR POSSESSION DOES NOT CONVEY ANY RIGHTS TO REPRODUCE, DISCLOSE ITS CONTENTS, OR TO MANUFACTURE, USE OR SELL ANYTHING IT MAY DESCRIBE. REPRODUCTION, DISCLOSURE OR USE WITHOUT SPECIFIC WRITTEN AUTHORIZATION OF B-K LIGHTING, INC. IS STRICTLY FORBIDDEN.

# GREG DAY Lighting

# Type G4

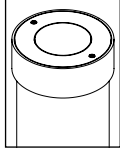

**BKSSL**  
SOLID STATE LIGHTING  
18-29W LED



## DENALI™ RECESSED UPLIGHT

PROJECT:	
TYPE:	

### FLUSH MOUNT

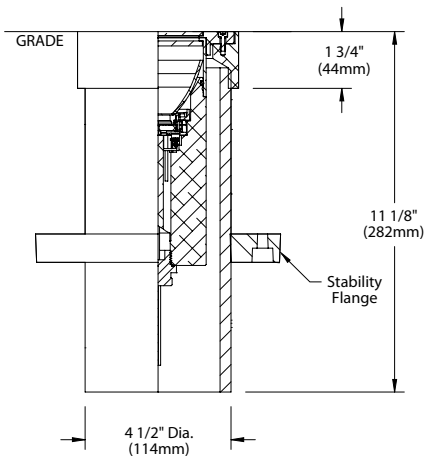
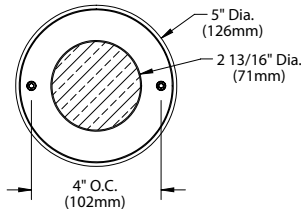

### SURFACE MOUNT

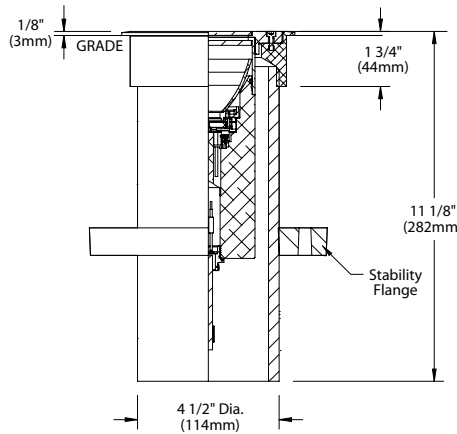
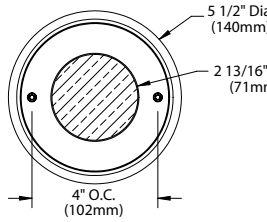

### STABILITY FLANGE

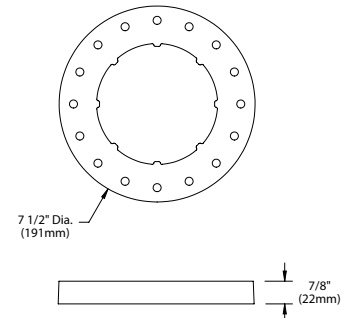

### Accessories (Configure separately)

#### Drivers:

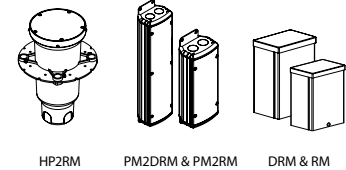

All dimensions indicated on this submittal are nominal.  
Contact Technical Sales if you require more stringent specifications.

## SPECIFICATIONS

### GreenSource Initiative™

Metal and packaging components are made from recycled materials. Manufactured using renewable solar energy, produced on site. Returnable to manufacturer at end of life to ensure cradle-to-cradle handling. Packaging contains no chlorofluorocarbons (CFC's). Use of this product may qualify for GreenSource efficacy and recycling rebate(s). Consult [www.bklighting.com/greensource](http://www.bklighting.com/greensource) for program requirements.

### Materials

Furnished in Copper-Free Aluminum (Type 6061-T6), Brass (Type 360) or Stainless Steel (Type 304).

### Body

Fully machined from solid billet. Unibody design provides enclosed, water-proof wireway and integral heat sink for maximum component life. Provided with hard-coat (Type III) black anodize finish for maximum corrosion resistance. Weather-tight cable connector with 5' 18Ga., 2 wire low voltage cable. High temperature, silicone 'O' Ring provides water-tight seal.

### Housing

Fixture provided with 4-1/2" dia., Schedule 80 PVC housing for direct burial into soil or concrete. 7.5" dia., molded stability flange projects into substrate to simplify installation and reinforce housing stability.

### Faceplate

Fully machined from solid billet. Countersunk holes provide for flush hardware mounting. Accommodates [2] lens or louver media.

### Lens

Shock resistant, tempered, glass lens is factory adhered to fixture cap and provides hermetically sealed optical compartment. Specify (#10) spread lens, soft focus (#12) or rectilinear (#13) lens.

### BKSSL™

Integrated solid state system with 'X' technology is scalable for field upgrade. Modular design with electrical quick disconnects permit field maintenance.

LM-80 certified. Minimum 50,000 hour rated life at 70% of initial lumens (L70). BKSSL technology provides long life, significant energy reduction and exceptional thermal management.

### Color Management

Corrected cold phosphor technology delivers near-perfect natural white light. Long term phosphor maintenance over product life. Exact color point conformity exceeds ANSI C78.377 standard. Provides uniform beam with no color variation over angle. Module exceeds 80 CRI (RA>80, R9>16).

### Installation

Flush Mount features integral concrete pour collar. Top edge of collar to be installed flush with finished grade. Collar material and finish to match faceplate. (2) Threaded holes for faceplate installation. Faceplate is suitable for walk-over and drive-over applications to 35,000 lbs. GVW.

Surface Mount features fully machined copper-free aluminum installation collar. Collar material and finish to match faceplate. (2) Threaded holes for faceplate installation.

### Remote Driver

For use with remote LED driver. See remote driver submittal to determine remote distance and wiring requirements prior to detailing field installation of any remote wiring.

### Driver

1A, Class A, constant current driver. 120-277VAC (nominal) primary input voltage. 50/60Hz. >0.94 Power Factor, <15.0A in-rush current, 0.25A input current, ≤20%THD (nominal at 120VAC full load). Output over-voltage, over-current, and short circuit protection with auto recovery. EMC: FCC47CFR Part 15 Class B compliant.

Dimming driver for use with standard incandescent dimmers. 10-100% range.

### Optics

Interchangeable OPTIKIT™ modules permit field changes to optical distribution.

### Wiring

PVC coated, 18AWG, 150V, 60°C rated and certified to UL 1838 standard. Anti-Siphon Valve (ASV™) prevents "wicking" through conductor insulation.

### Hardware

Tamper-resistant, stainless steel hardware. Faceplate screws are additionally black oxide treated for additional corrosion resistance.

### Finish

StarGuard®, our exclusive RoHs compliant, 15 stage chromate-free process cleans and conversion coats aluminum components prior to application of Class 'A' TGIC polyester powder coating. Brass components are available in powder coat or handcrafted metal finish. Stainless steel components are available in handcrafted metal finish. (Brushed finish for interior use only).

### Warranty

5 year limited warranty.

### Certification and Listing

ITL tested to IESNA LM-79. Lighting Facts Registration per USD OE ([www.lightingfacts.com](http://www.lightingfacts.com)). ETL Listed to ANSI/UL Standard 1598 and UL Standard 8750. Certified to CAN/CSA Standard C22.2 No. 250. RoHs compliant. Suitable for indoor or outdoor use. Suitable for use in wet locations. Suitable for installation within 4' of the ground. IP66 Rated. Made in USA.



<b>B-K LIGHTING</b>	40429 Brickyard Drive • Madera, CA 93636 • USA 559.438.5800 • FAX 559.438.5900 <a href="http://www.bklighting.com">www.bklighting.com</a> • <a href="mailto:info@bklighting.com">info@bklighting.com</a>	RELEASED 07-10-15	DRAWING NUMBER SUB-2323-00
	<p style="text-align: right;"><b>Greg Day Lighting</b></p>		