

X1E EXISTING - EXTERIOR BRICK 	X2E EXISTING - EXTERIOR BRICK 	X3E EXISTING - EXTERIOR BRICK 	1E EXISTING - INTERIOR BRICK 
X4E EXISTING - EXTERIOR DORMER 	X4N NEW - EXTERIOR DORMER 	X5N NEW - EXTERIOR WOOD PANEL @ ENTRY 	
2E EXISTING - WOOD STUD, NON RATED 	2N NEW - INTERIOR 3 5/8 inch METAL STUD W/ INSULATION 	2E-1 EXISTING - INTERIOR WOOD STUD - 1-HOUR FIRE RATED 	2N-1 NEW - INTERIOR 3 5/8 inch METAL STUD - 1-HOUR FIRE RATED 
3N NEW - INTERIOR 6 inch METAL STUD W/ INSULATION 	2NA NEW - INT 3 5/8 inch MTL STUD W/ INSULATION & CONTINUOUS RESILIENT CHANNEL 	3E-1 EXISTING - INTERIOR WOOD STUD - 1-HOUR FIRE RATED 	2N-2 NEW - INTERIOR 4 inch METAL STUD - 2-HOUR FIRE RATED 
4N NEW - EXTERIOR WALL FURRING 	5N NEW - INTERIOR WALL FURRING 	6N NEW - INTERIOR PLUMBING WALL 	
			 WALL TYPE TAG ON PLANS AND SECTIONS

○ WALL TYPES
1 1/2" = 1'-0"

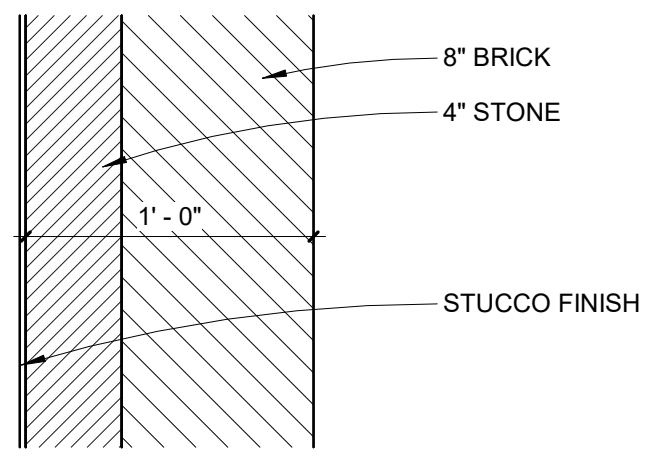

⑤ FOURTH FLOOR ASSEMBLY
1 1/2" = 1'-0"

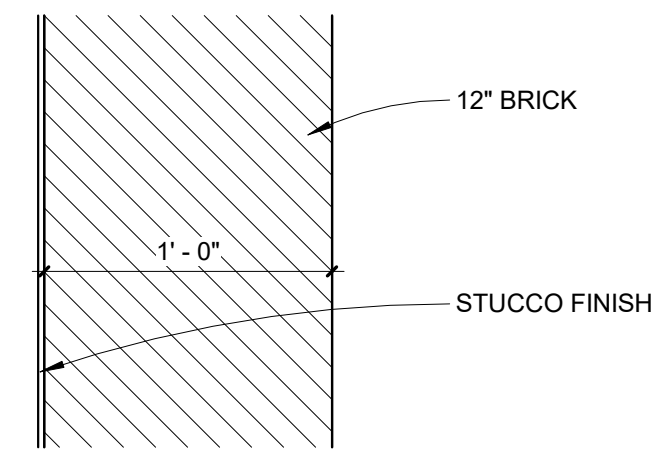
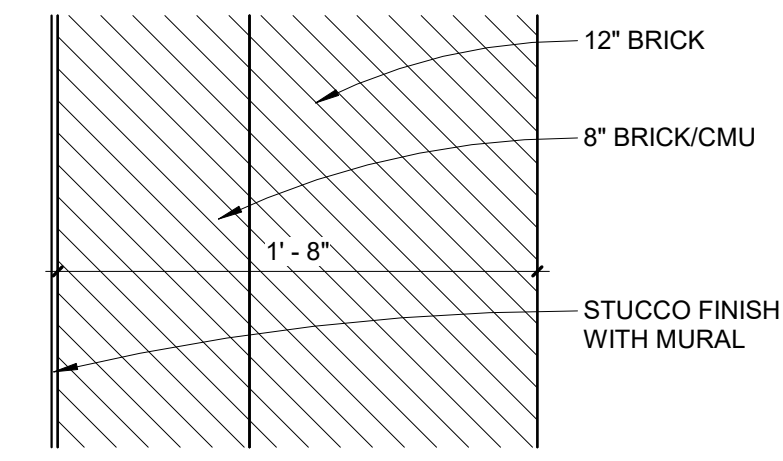
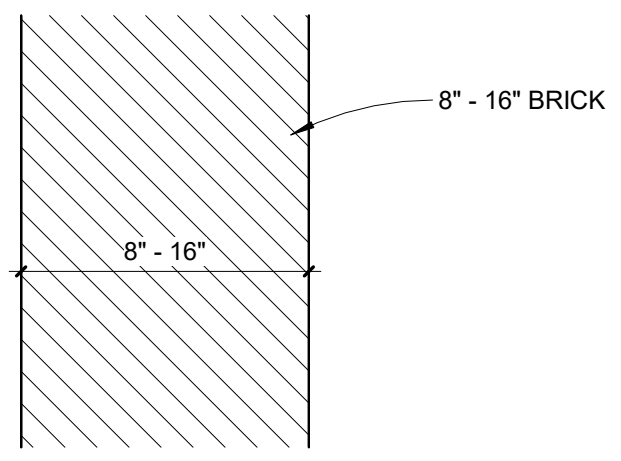
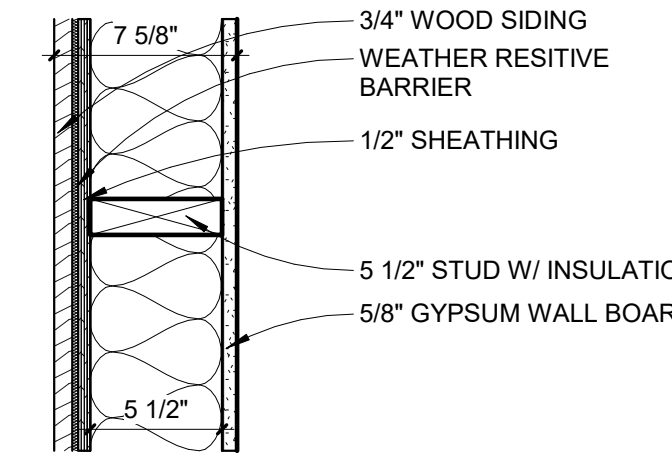
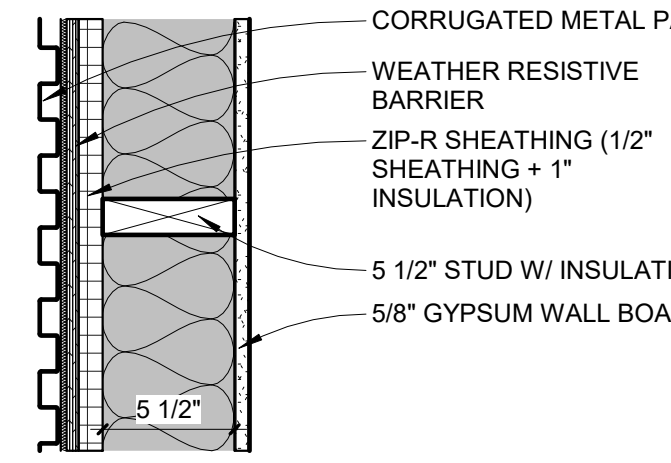
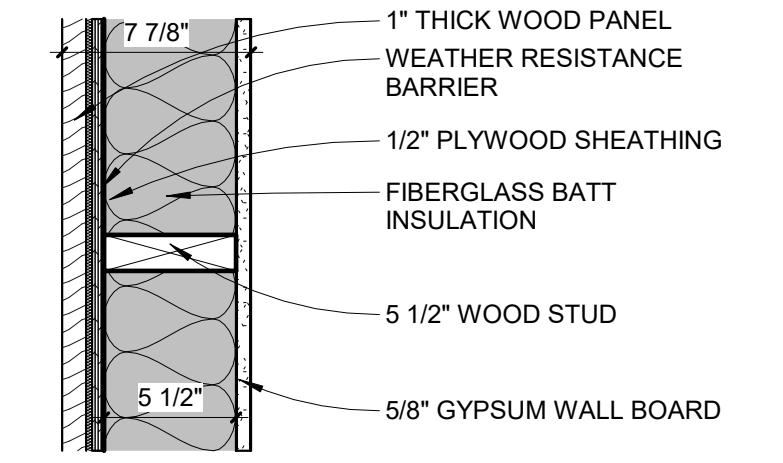
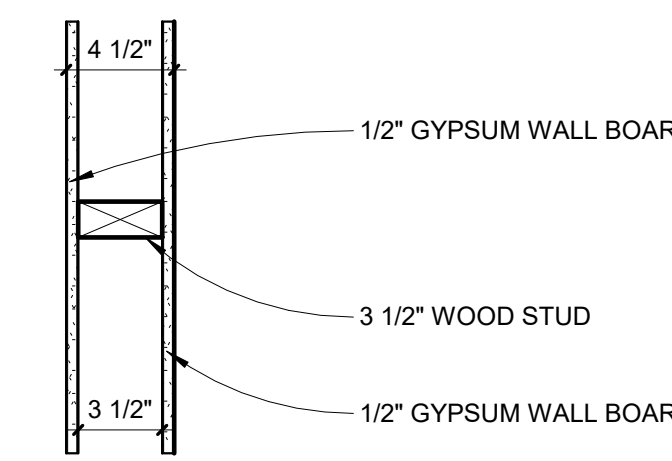
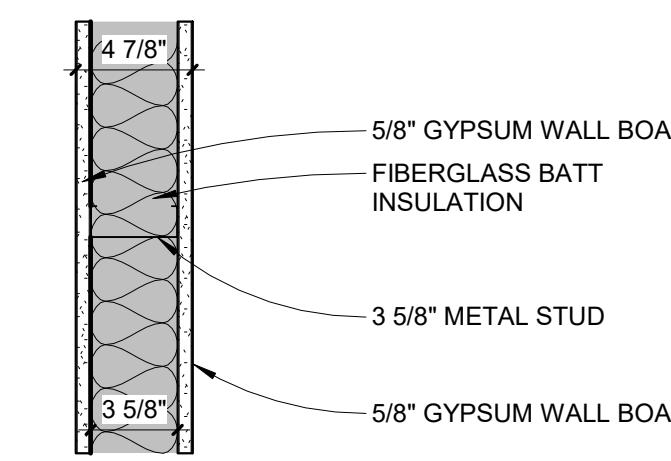
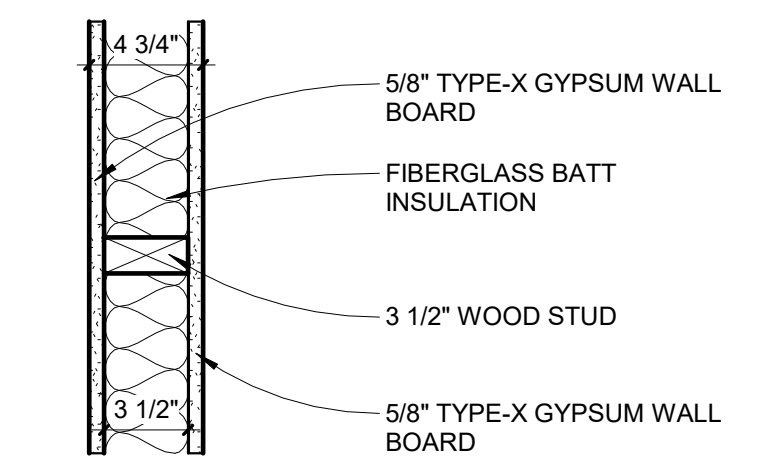
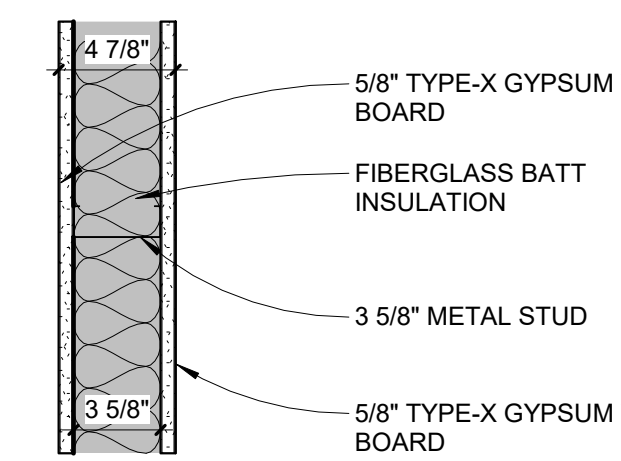
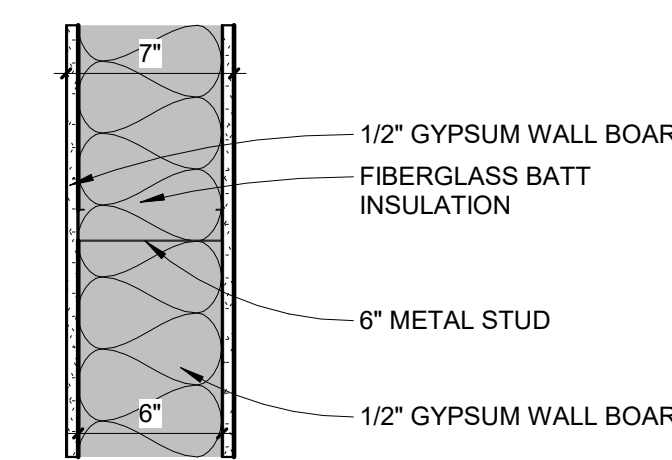
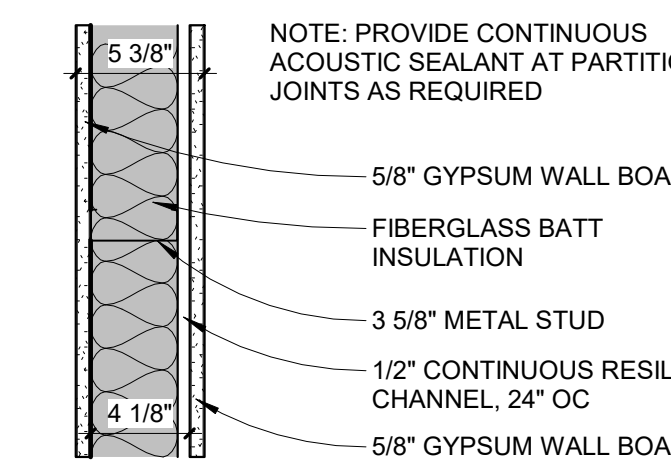
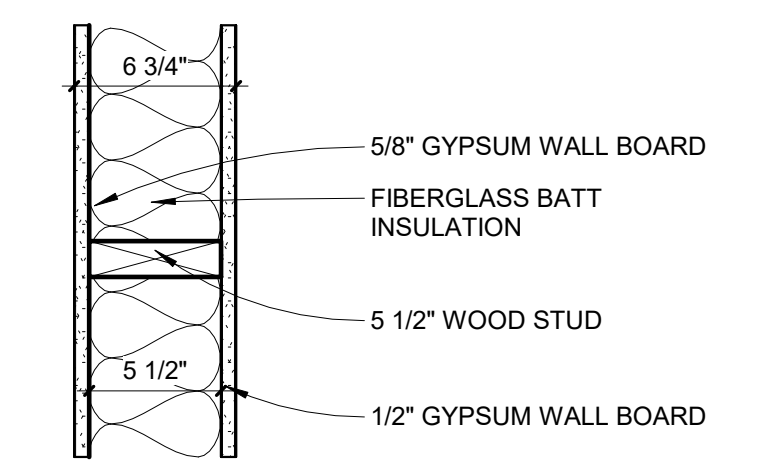
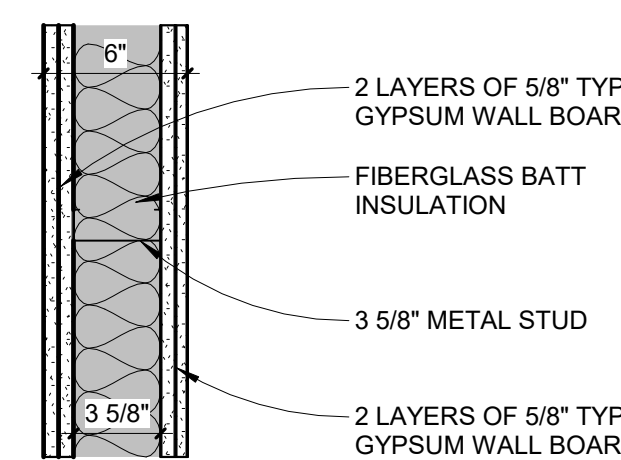
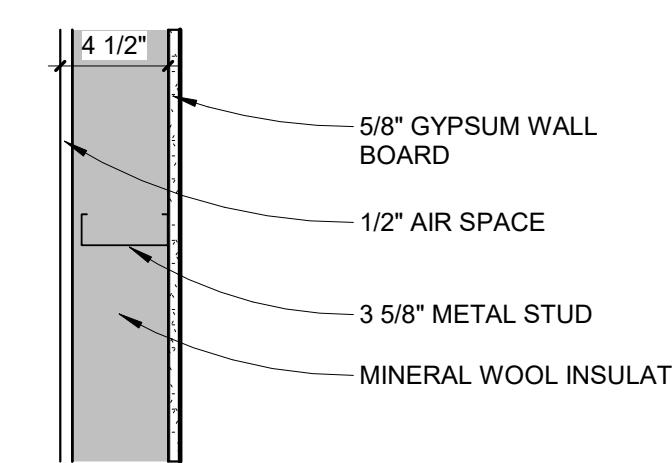
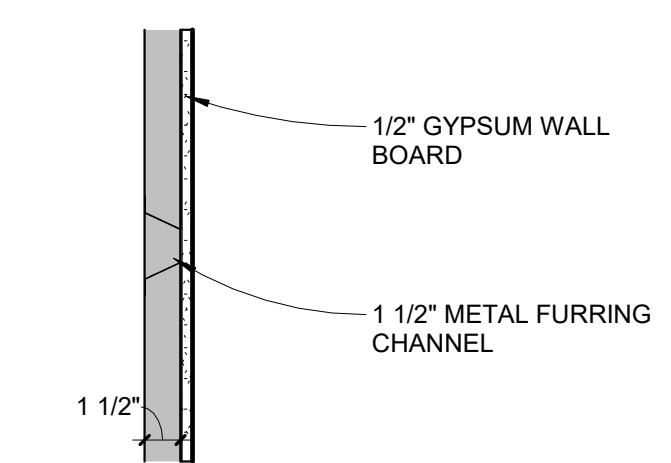
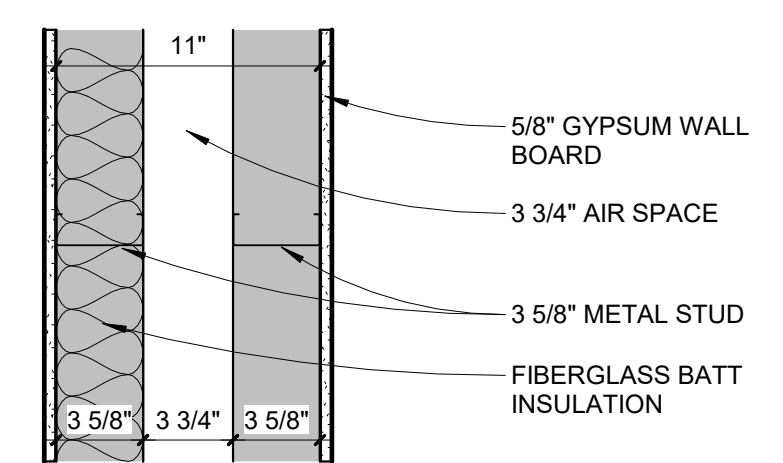
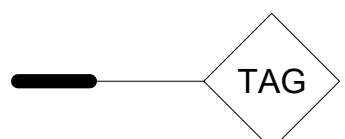
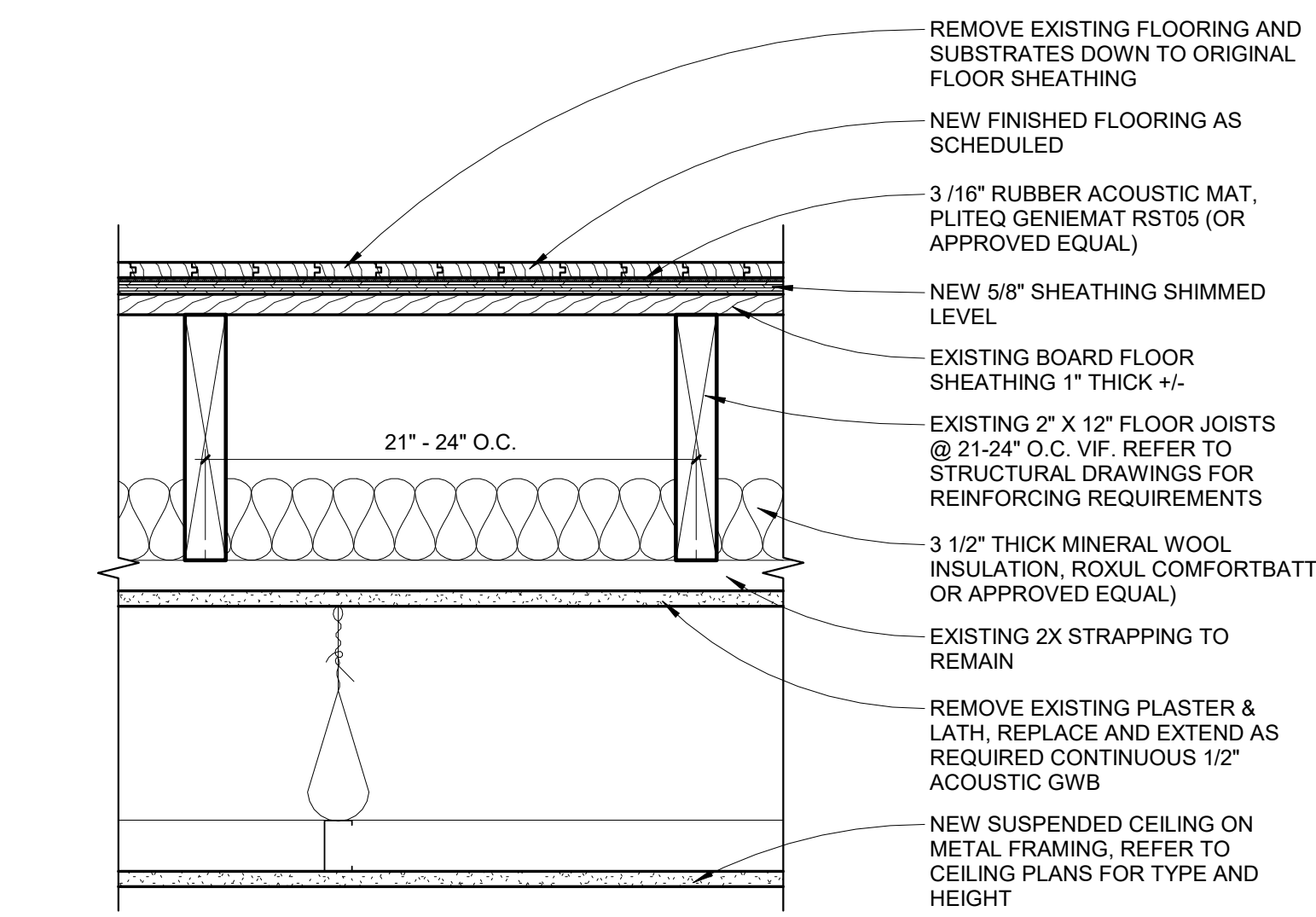
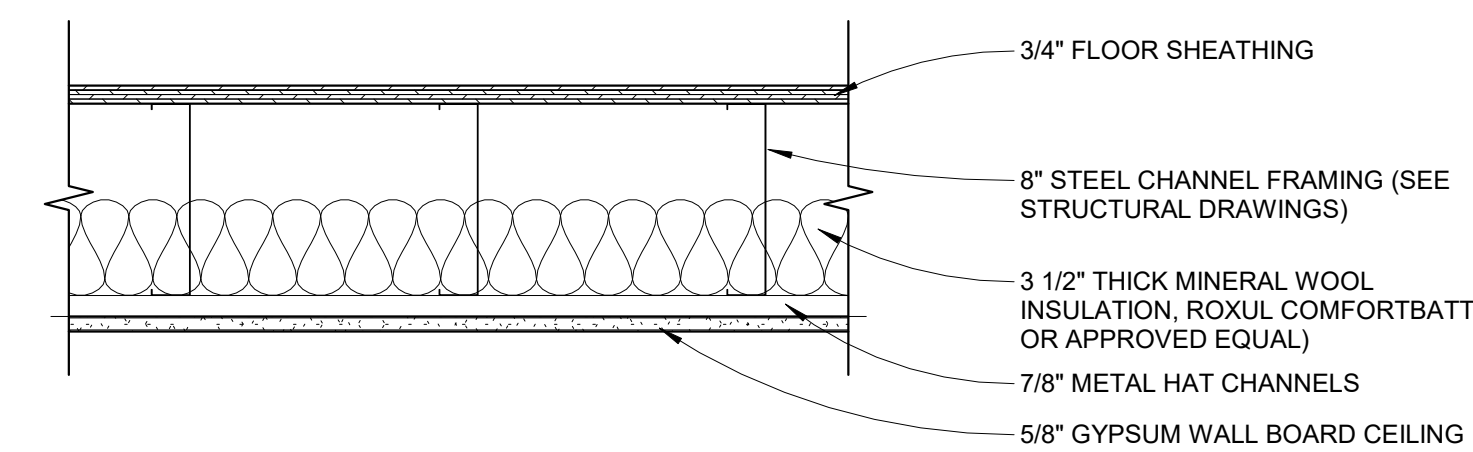

④ MEZZANINE FLOOR ASSEMBLY
1 1/2" = 1'-0"

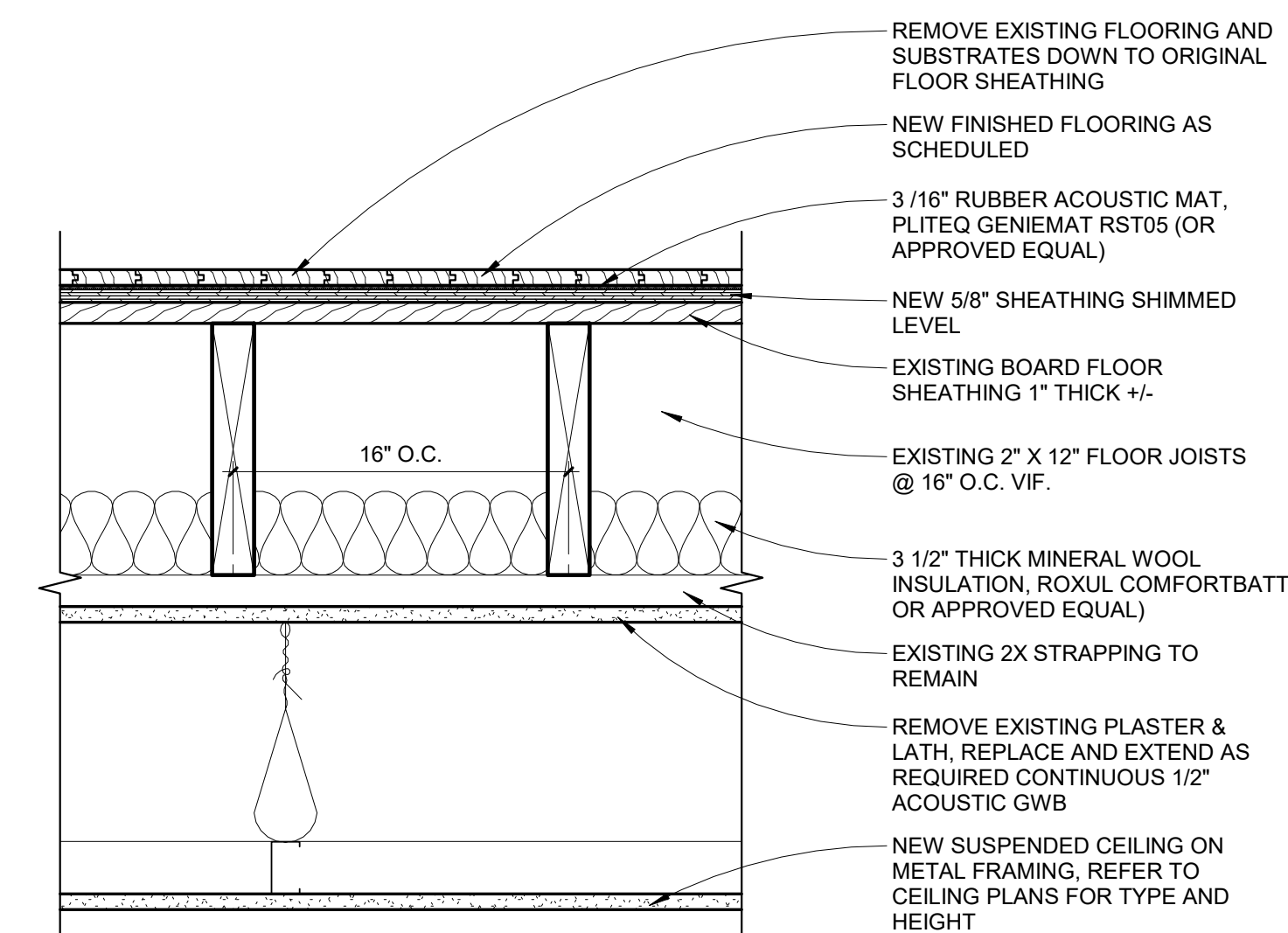

③ THIRD FLOOR ASSEMBLY
1 1/2" = 1'-0"

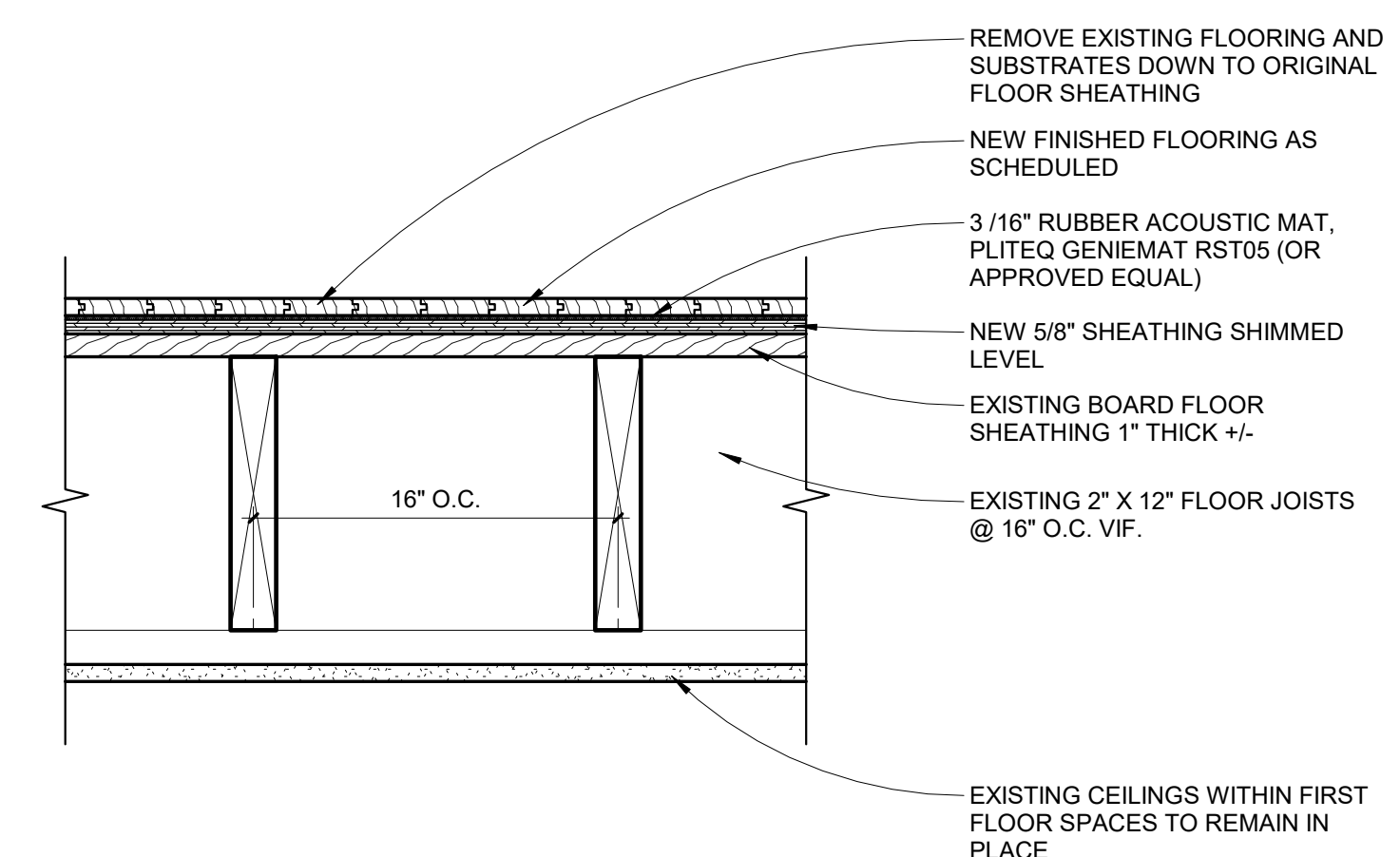

② SECOND FLOOR ASSEMBLY
1 1/2" = 1'-0"

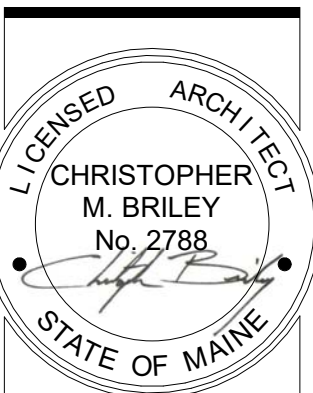

80 EXCHANGE STREET
PORTLAND, MAINE
OFFICE RENOVATION



CONSULTANTS:

REVISIONS:

No.	Name	Date
1	REV 1	1/5/18

ISSUED FOR PERMITTING

ISSUED: 11/01/17
PROJECT No: 1714
DRAWN BY: RIP
CHECKED BY:
SHEET TITLE:
TYPICAL ASSEMBLIES

A401