

City of Portland, Maine - Building or Use Permit Application

389 Congress Street, 04101 Tel: (207) 874-8703, Fax: (207) 874-8716

PERMIT ISSUED	
Permit No: 011421	Issue Date: DEC 13 2001
ECL: 032 F007001	

Location of Construction: 375 Fore St	Owner Name: Soley Joseph	Owner Address: Po Box 4894	Phone:
Business Name: Handfoot, LLC	Contractor Name: Woodward Thomsen Inc.	Contractor Address: PO Box 10359 Portland	Phone: 2077749298
Lessee/Buyer's Name	Phone:	Permit Type: Alterations - Commercial	Zone: B-3

Past Use: restaurant call 773-7210 when ready	Proposed Use: restaurant	Permit Fee: \$1,344.00	Cost of Work: \$220,000.00	CEO District: 1
--	------------------------------------	----------------------------------	--------------------------------------	---------------------------

Proposed Project Description: alterations, re-decorating	FIRE DEPT: <input checked="" type="checkbox"/> Approved <input type="checkbox"/> Denied	INSPECTION: Use Group: A3 Type: 5B 12/12/01
	Signature: <i>[Signature]</i>	Signature: <i>[Signature]</i>

Permit Taken By: jodinea	Date Applied For: 11/16/2001	Zoning Approval	
------------------------------------	--	------------------------	--

<ol style="list-style-type: none"> This permit application does not preclude the Applicant(s) from meeting applicable State and Federal Rules. Building permits do not include plumbing, septic or electrical work. Building permits are void if work is not started within six (6) months of the date of issuance. False information may invalidate a building permit and stop all work.. 	Special Zone or Reviews <input type="checkbox"/> Shoreland <i>N/A</i> <input type="checkbox"/> Wetland <input type="checkbox"/> Flood Zone <input type="checkbox"/> Subdivision <input type="checkbox"/> Site Plan Maj <input type="checkbox"/> Minor <input type="checkbox"/> MM <input type="checkbox"/> <i>Separate permits are required for any new sign work</i> <i>[Signature]</i> Date: 1/12/01	Zoning Appeal <input type="checkbox"/> Variance <input type="checkbox"/> Miscellaneous <input type="checkbox"/> Conditional Use <input type="checkbox"/> Interpretation <input type="checkbox"/> Approved <input type="checkbox"/> Denied Date:	Historic Preservation <input type="checkbox"/> Not in District or Landmark <input type="checkbox"/> Does Not Require Review <input type="checkbox"/> Requires Review <input type="checkbox"/> Approved <input type="checkbox"/> Approved w/Conditions <input type="checkbox"/> Denied <i>Any exterior work requires a separate review</i> Date:
---	--	---	--

CERTIFICATION

I hereby certify that I am the owner of record of the named property, or that the proposed work is authorized by the owner of record and that I have been authorized by the owner to make this application as his authorized agent and I agree to conform to all applicable laws of this jurisdiction. In addition, if a permit for work described in the application is issued, I certify that the code official's authorized representative shall have the authority to enter all areas covered by such permit at any reasonable hour to enforce the provision of the code(s) applicable to such permit.

SIGNATURE OF APPLICANT _____ ADDRESS _____ DATE _____ PHONE _____

RESPONSIBLE PERSON IN CHARGE OF WORK, TITLE _____ DATE _____ PHC _____

1-7-02

Inspected ceiling area 1st floor
OK to close in existing
ceiling 2x4 strapping
mm

3/5/02 Plumbing, Framing o/c. AR

3/15/02 ok for CJB AR

32-F-7

01-1421

01-1401

All Purpose Building Permit Application

If you or the property owner owes real estate or personal property taxes or user charges on any property within the City, payment arrangements must be made before permits of any kind are accepted.

Location/Address of Construction: 375 Fore Street

Total Square Footage of Proposed Structure 6100 Square Footage of Lot

Tax Assessor's Chart, Block & Lot
Chart# 032 Block# F Lot# 007 Owner: Joseph Sotey Telephone:

Lessee/Buyer's Name (If Applicable) Hand and Foot, LLC Applicant name, address & telephone: P.O. Box 531
Portland, ME 04112 Cost Of Work: \$ 220,000.
Fee: \$ 1,344.00

Current use: _____
If the location is currently vacant, what was prior use: Restaurant/Pubs
Approximately how long has it been vacant: 1 year
Proposed use: Restaurant/Pubs (Same)
Project description: Alterations, redecorating as specified in attached plan.

Contractor's name, address & telephone: Woodward Thomsen Co.
Who should we contact when the permit is ready: Douglas Furr / Hand and Foot, LLC
Mailing address: P.O. Box 531
Portland, ME 04112 xx call
Phone: 773-7210

IF THE REQUIRED INFORMATION IS NOT INCLUDED IN THE SUBMISSIONS THE PERMIT WILL BE AUTOMATICALLY DENIED AT THE DISCRETION OF THE BUILDING/PLANNING DEPARTMENT, WE MAY REQUIRE ADDITIONAL INFORMATION IN ORDER TO APPROVE THIS PERMIT.

I hereby certify that I am the Owner of record of the named property, or that the owner of record authorizes the proposed work and that I have been authorized by the owner to make this application as his/her authorized agent. I agree to conform to all applicable laws of this jurisdiction. In addition, if a permit for work described in this application is issued, I certify that the Code Official's authorized representative shall have the authority to enter all areas covered by this permit at any reasonable hour to enforce the provisions of the codes applicable to this permit.

Signature of applicant: [Signature] Date: 11/14/01

This is not a permit, you may not commence ANY work until the permit is issued

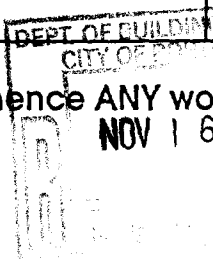

11/16/01
Gay

DUPLICATE

GENERAL RECEIPT

CITY OF PORTLAND, MAINE

DEPARTMENT Inspection DATE 11/16/01
RECEIVED FROM Hand and Food LLC
ADDRESS 355 Fair Street

UNIT	ITEM	REVENUE CODE	DOLLAR AMOUNT
	Building		1344.00
	Check # 212156809		
	CBL 032-FOOD		

CASH CHECK OTHER TOTAL 1344.00

RECEIVED BY Jay

Application ID Number: 1-1421

Department: Zoning

Status: Approved with Conditions

Reviewer: Marge Schmuckal

Comments: 375 Fore St
(previously the Seaman's Club)

Approval Date: 11/20/2001

Given On Date: 11/20/2001

OK to Issue Permit Name: Marge Schmuckal Date: 11/20/2001 Date 2:

Conditions Section:

This permit is being approved on the basis of plans submitted. Any deviations shall require a separate approval before starting that work.

Separate permits shall be required for any new signage.

The plans were presented that this is all one occupation for Bull Feeney's Irish pub. These shall not be separate entities which require separate licenses thru the City Clerks office.

Any exterior work shall require a separate review and approval.

Create Date: 11/20/2001 By: jodinea Update Date: 11/20/2001 By: mes

01-1421
032-F-007

Hand and Foot LLC
P. O. Box 531
Portland, Maine 04112

Woodward Thomsen Co.P.O.
Box 10359. PORTLAND,
Maine 04104

25-Jan-02

RE: BULL FEENEY'S

Dear Thomas,

As our project at Bull Feeney's is winding down and the work we've contracted with Woodward Thomsen is now more or less complete, we have elected to name ourselves as general contractors of record on the project from this time forward and until the project's completion. We have notified the Mike Nugent of the City of Portland building inspectors office of this change in writing.

Beginning Monday, we respectfully request that any services that you and your employees have been providing cease. In addition, please deliver the materials we have already purchased, i.e. the maple flooring, in as timely a fashion as possible. Please be sure that we have access to the three locations storing our kitchen equipment and we will arrange for delivery from those locations back to our premises.

We will provide you with payment for the outstanding invoice agreed upon as per invoice 9th January, as soon as possible. We also will actively work toward finding a mutually agreeable settlement for the remaining outstanding invoice which is in dispute and any additional services performed to date.

Thank you for all of the help you have provided over the course of the last several months. Your contribution to our project is respectfully appreciated.

Yours Sincerely,

Douglas Fuss

Gerard Hand

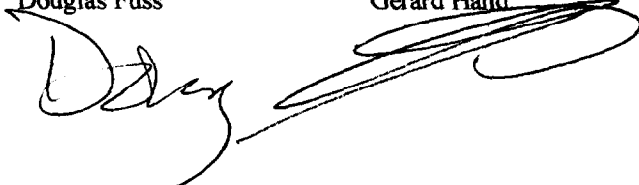

cc: Michael Nugent, Building Inspector, Portland

Memorandum

To: Woodward Thomsen Co.
CC: Turk, Tracey & Larry
From: Mike Nugent/Manager of Inspection Services
Date: 12/03/2001
Re: 375 Fore St. (032 F007)

This office has commenced the review of the plans for the renovation of the above premises. Because the value of renovation exceeds \$50,000, in cost, the technical submissions must be stamped by the design professional. Please submit these as soon as possible to avoid delays in the review process.

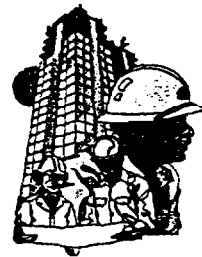
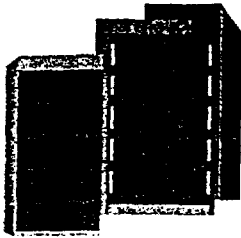

**CITY OF PORTLAND
BUILDING CODE CERTIFICATE
389 Congress St., Rm 315
Portland, ME 04101**

TO: Inspector of Buildings City of Portland, Maine
Department of Planning & Urban Development
Division of Housing & Community Service

FROM: _____

RE: Certificate of Design

DATE: _____

These plans and/or specifications covering construction work on:

Have been designed and drawn up by the undersigned, a Maine registered architect/engineer according to the BOCA National Building Code/1999 Fourteenth Edition, and local amendments.

(SEAL)

Signature _____

Title _____

Firm _____

Address _____

As per Maine State Law:

\$50,000.00 or more in new construction, repair, expansion, addition, or modification for Building or Structures, shall be prepared by a registered design Professional.

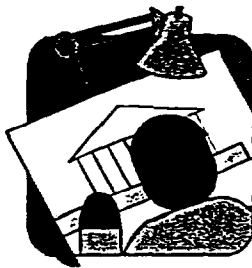

CITY OF PORTLAND MAINE

389 Congress St., Rm 315

Portland, ME 04101

Tel. - 207-874-8704

Fax - 207-874-8716

TO: Inspector of Buildings City of Portland, Maine
Planning & Urban Development
Division of Housing & Community Services

FROM DESIGNER: _____

DATE: _____

Job Name: _____

Address of Construction: _____

THE BOCA NATIONAL BUILDING CODE/1999 Fourteenth EDITION

Construction project was designed according to the building code criteria listed below:

Building Code and Year _____ Use Group Classification(s) _____

Type of Construction _____ Bldg. Height _____ Bldg. Sq. Footage _____

Seismic Zone _____ Group Class _____

Roof Snow Load Per Sq. Ft. _____ Dead Load Per Sq. Ft. _____

Basic Wind Speed (mph) _____ Effective Velocity Pressure Per Sq. Ft. _____

Floor Live Load Per Sq. Ft. _____

Structure has full sprinkler system? Yes _____ No _____ Alarm System? Yes _____ No _____
Sprinkler & Alarm systems must be installed according to BOCA and NFPA Standards with approval from the Portland Fire Department.

Is structure being considered unlimited area building: Yes _____ No _____

If mixed use, what subsection of 313 is being considered _____

List Occupant loading for each room or space, designed into this Project.

(Designers Stamp & Signature)

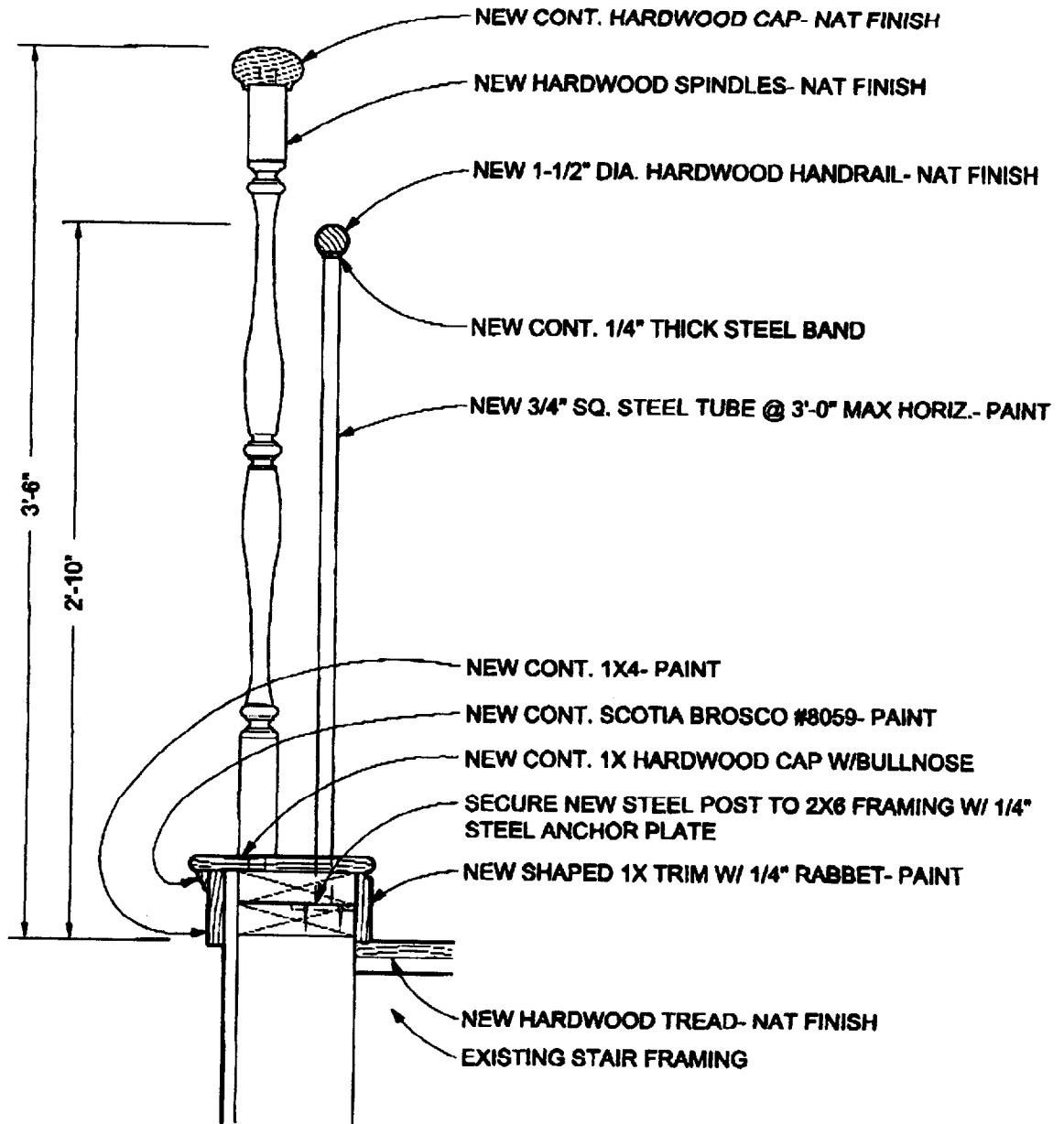

9
A-8

SECTION @ NEW GUARD/HANDRAIL

1 1/2" = 1'-0"

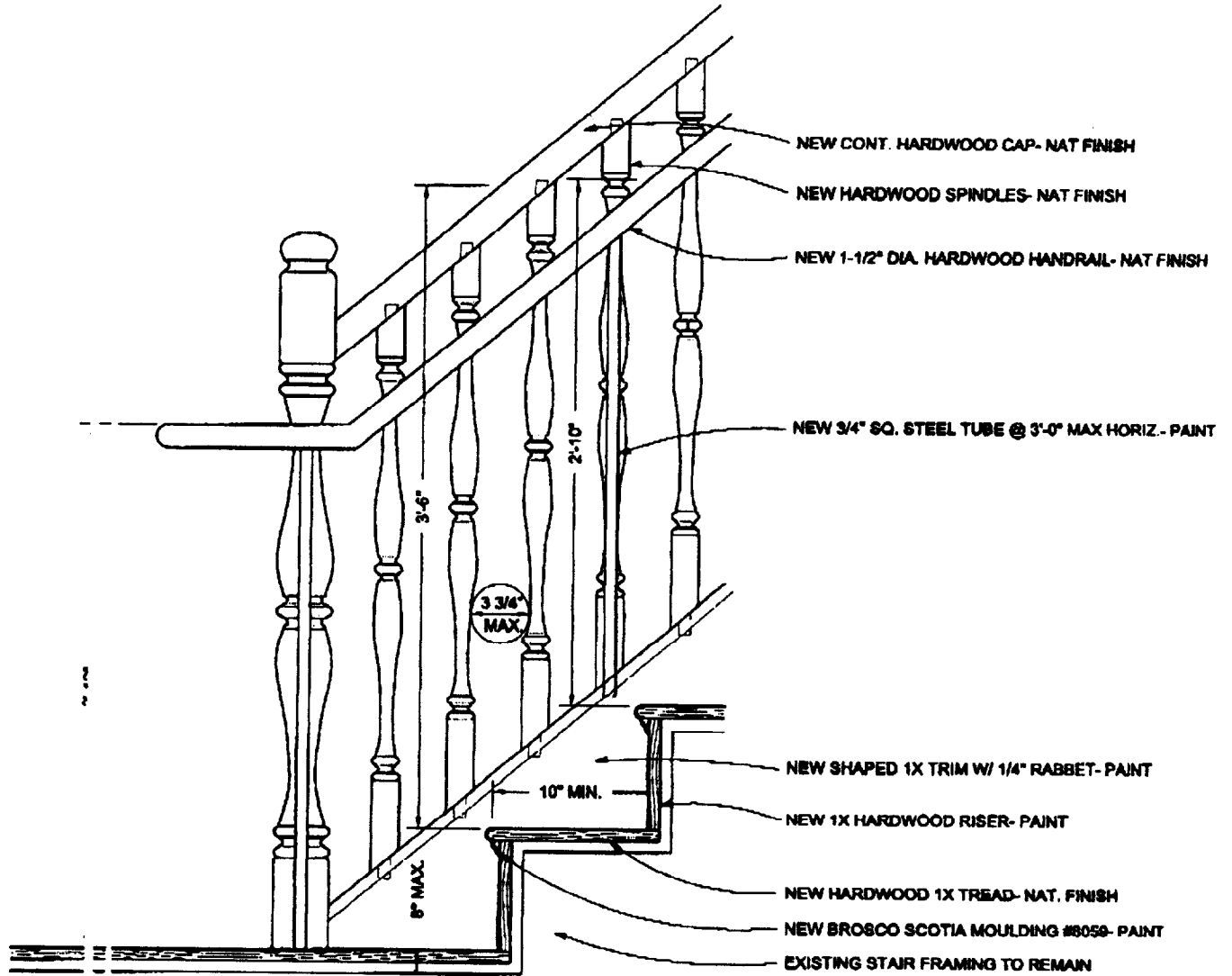

8
A-8

SECTION @ EXISTING STAIR/NEW BALUSTRADE

1 1/2" = 1'-0"

RE: Bull Feeneys
New balustrades.

Post-It® Fax Note	7671	Date	12 DEC	# of pages	3
To	MIKE NUGENT	From	JOHN TURK		
Co./Dept.	Pict. Inspections	Co.	TTLA		
Phone #		Phone #	761-9662		
Fax #	824-8716	Fax #			

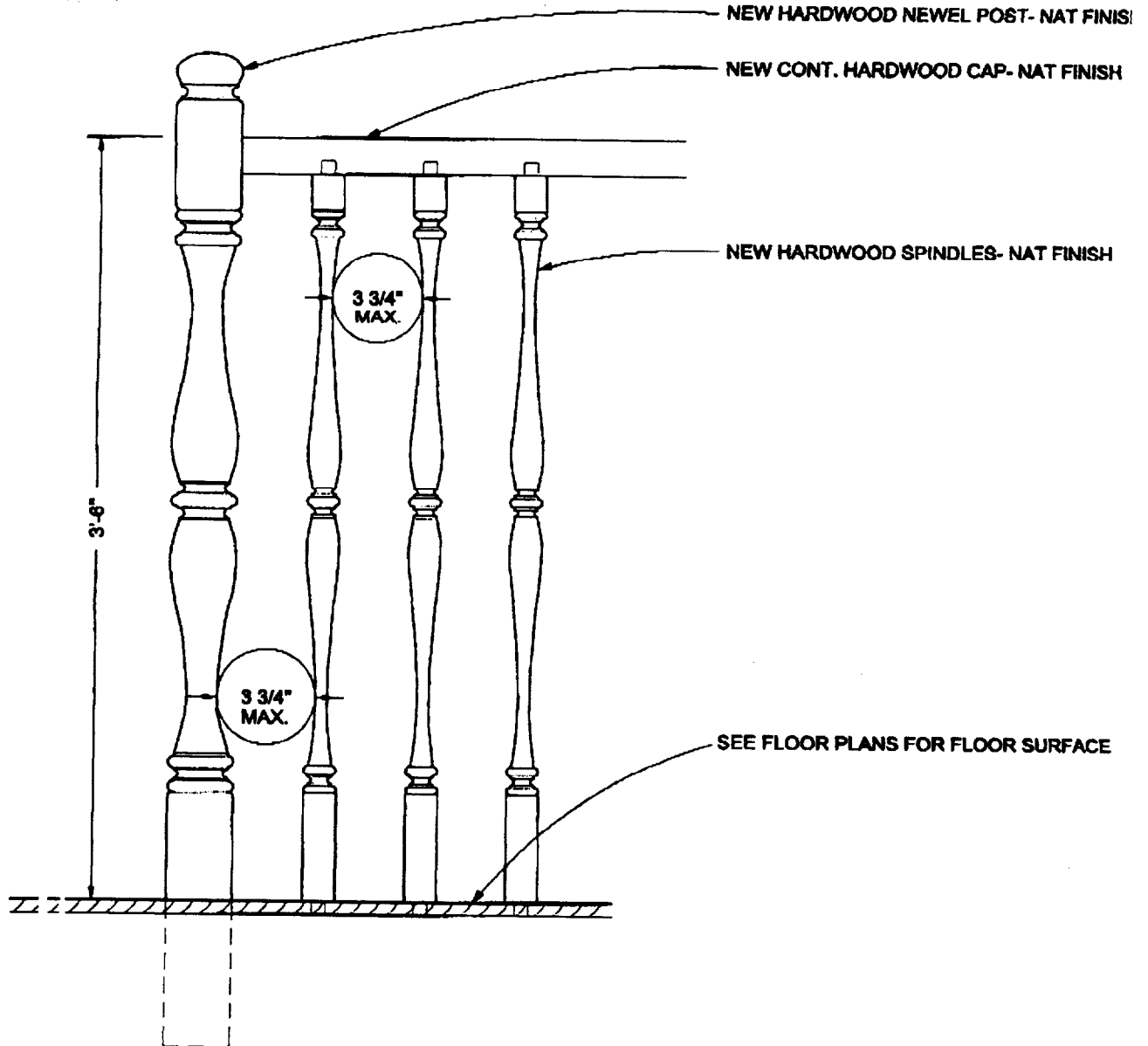

7
A-8

ELEVATION @ NEW BALUSTRADE/GUARDRAIL

1/2" = 1'-0"

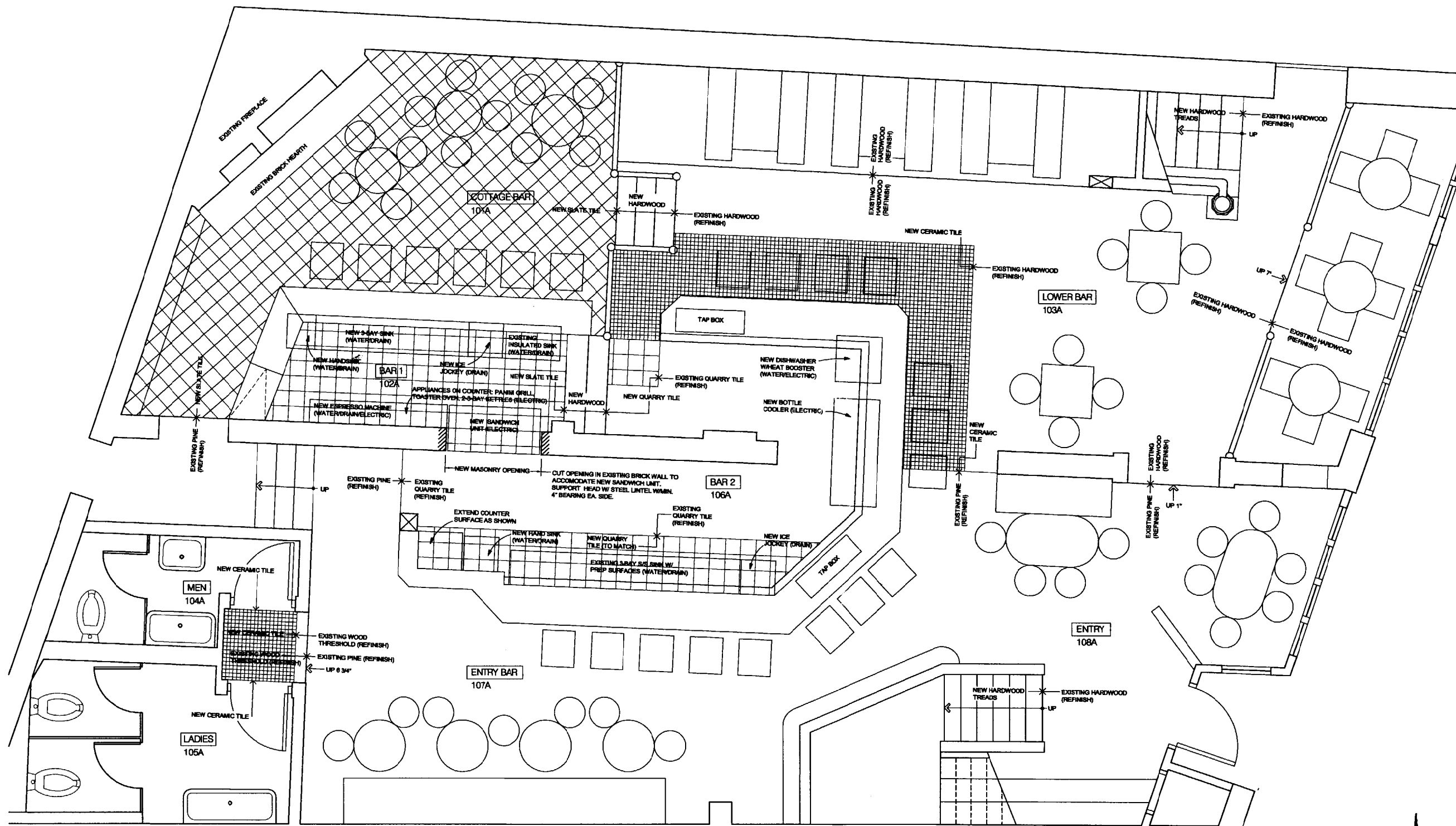

1 NEW FIRST FLOOR REFLECTED CEILING PLAN A-BAY



GENERAL NOTES:

1. FUTURE AND APPLIANCE DIAGRAMS ARE SHOWN FOR BASIC INFORMATIONAL PURPOSES ONLY. CONTRACTOR TO VERIFY DIMENSIONAL, PLUMBING, ELECTRICAL OR OTHER WORK REQUIRED TO ENABLE THE PROPER FUNCTIONING OF EACH COMPONENT.
2. ALL APPLICABLE CODE REQUIREMENTS REGARDING KITCHEN & BAR DESIGN AND EQUIPMENT REQUIREMENTS SHALL BE THE RESPONSIBILITY OF THE OWNER AND KITCHEN EQUIPMENT SUPPLIER/DESIGNER.
3. SEE REFLECTED CEILING PLANS FOR LIGHTING AND POWER DIAGRAMS.

*GERARD-HANDS
DUG FORS
P.O. Box 531
PORT 04112*

Owner:
DOUGLAS FUSSELL
GERARD HAND
HAND & FOOT, LLC
P.O. BOX 531
TEL. 207.773.7210

TURK TRACEY & LARRY
ARCHITECTS, LLC
82 EXCHANGE STREET
PORTLAND, MAINE 04101
TEL. 207.781.9882
FAX. 207.781.9888

Contractor:
WOODWARD THOMSEN CO.
50 PORTLAND STREET
PORTLAND, MAINE 04101
TEL. 207.774.9298
FAX. 207.774.0031

Rehabilitation of the Seaman's Club Building
BULL FEENEY'S IRISH PUB
375 FORE STREET
PORTLAND, MAINE

Date: 1 November 2001
Scale: As Shown
Revisions:

Title:
Progress
New First Floor
Plan A-Bay
Sheet:
A-1

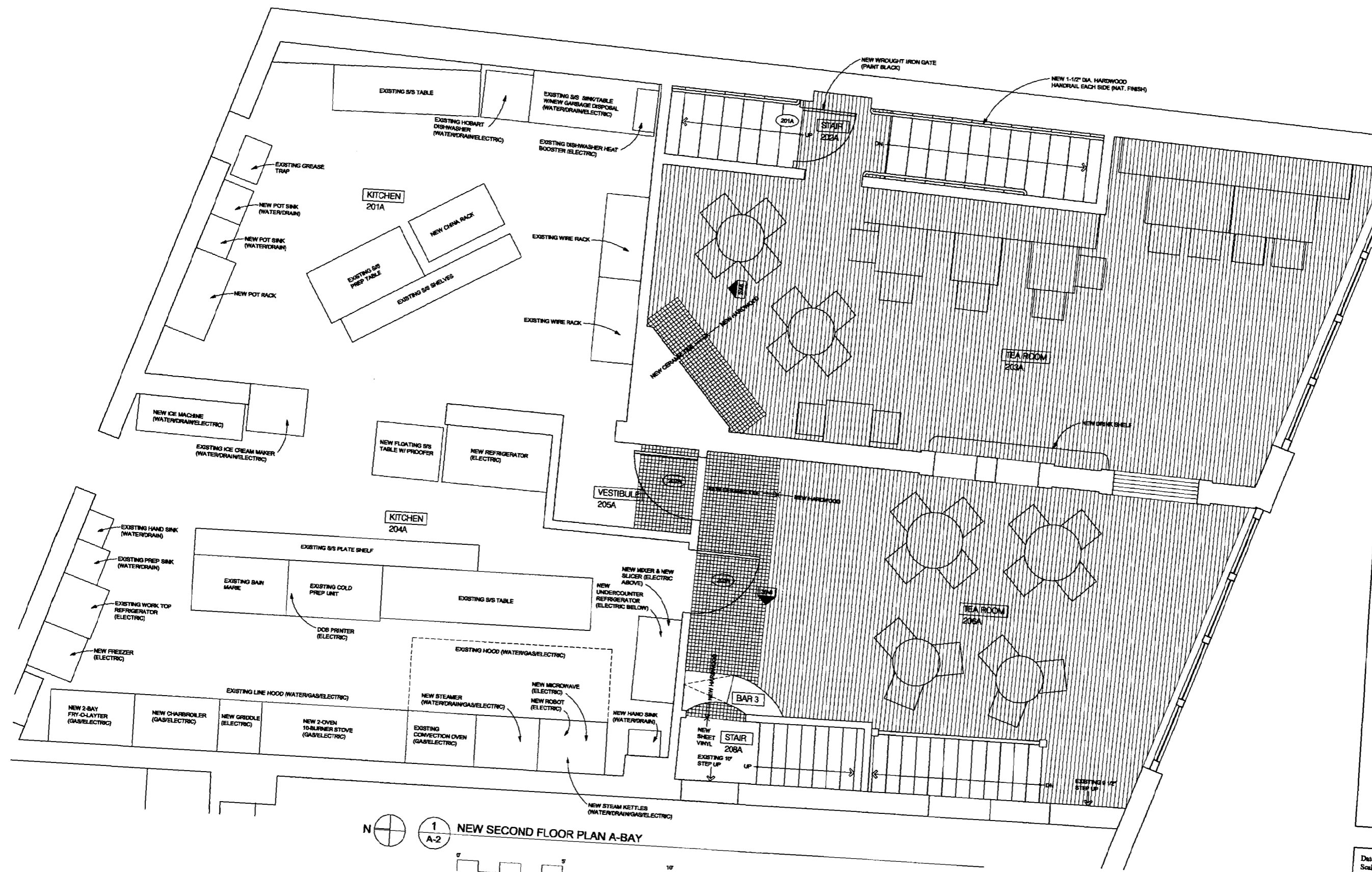

1
A-2
NEW SECOND FLOOR PLAN A-BAY

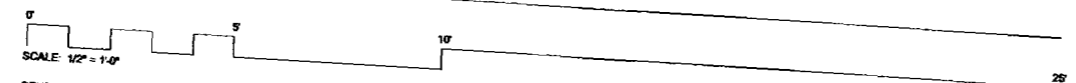

- GENERAL NOTES:
1. FIXTURE AND APPLIANCE DIAGRAM IS SHOWN FOR LOCATIONAL PURPOSES ONLY. CONTRACTOR TO VERIFY DIMENSIONAL, PLUMBING, ELECTRICAL OR OTHER WORK REQUIRED TO ENABLE THE PROPER FUNCTIONING OF EACH COMPONENT.
 2. ALL APPLICABLE CODE REQUIREMENTS REGARDING KITCHEN & BAR DESIGN AND EQUIPMENT REQUIREMENTS SHALL BE THE RESPONSIBILITY OF THE OWNER AND KITCHEN EQUIPMENT SUPPLIER/DISIGNER.
 3. SEE REFLECTED CEILING PLANS FOR LIGHTING AND POWER DIAGRAMS.

Owner:
DOUGLAS FLISS
GERARD HAND
HAND & FOOT, LLC
P.O. BOX 531
TEL. 207.773.7210

TURK TRACEY & LARRY
ARCHITECTS, LLC
82 EXCHANGE STREET
PORTLAND, MAINE 04101
TEL. 207.761.9882
FAX. 207.761.9998

Contractor:
WOODWARD THOMSEN CO.
80 PORTLAND STREET
PORTLAND, MAINE 04101
TEL. 207.774.8288
FAX. 207.774.0331

Rehabilitation of the Seaman's Club Building
BULL FEENEY'S IRISH PUB
 375 FORE STREET
 PORTLAND, MAINE

Date: 1 November 2001
Scale: As Shown
Revisions:

Title:
Progress
New Second Floor
Plan A-Bay
Sheet:
A-2

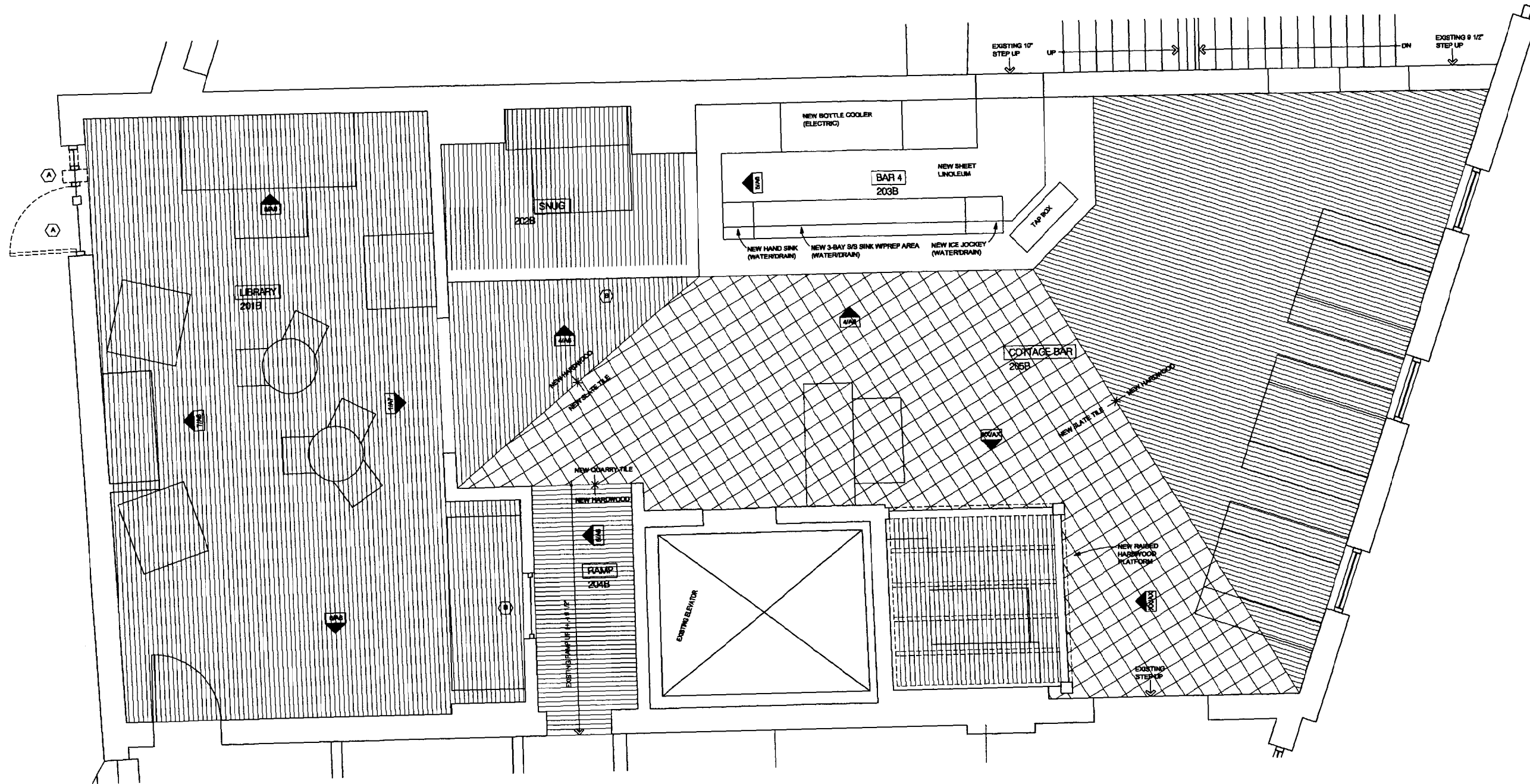

Owner:
 DOUGLAS FUSB
 GERARD HANDE
 HAND & FOOT, LLC
 P.O. BOX 531
 TEL. 207.773.7210

Contractor:
 WOODWARD THOMSEN CO.
 90 PORTLAND STREET
 PORTLAND, MAINE 04101
 TEL. 207.774.3228
 FAX. 207.774.0331

Rehabilitation of the Seaman's Club Building
BULL FEENEY'S IRISH PUB
 375 FORE STREET
 PORTLAND, MAINE

Date: 1 November 2001
 Scale: As Shown
 Revisions:

Title:
 Progress
 New Second Floor
 Plan B-Bay
 Sheet:
A-3

1
 A-3
NEW SECOND FLOOR PLAN B-BAY

0 5 10 20

SCALE: 1/2" = 1'-0"

- GENERAL NOTES:
1. FIXTURE AND APPLIANCE DIAGRAM ARE SHOWN FOR LOCATIONAL PURPOSES ONLY. CONTRACTOR TO VERIFY DIMENSIONAL, PLUMBING, ELECTRICAL OR OTHER WORK REQUIRED TO ENABLE THE PROPER FUNCTIONING OF EACH COMPONENT.
 2. ALL APPLICABLE CODE REQUIREMENTS REGARDING KITCHEN & BAR DESIGN AND EQUIPMENT REQUIREMENTS SHALL BE THE RESPONSIBILITY OF THE OWNER AND KITCHEN EQUIPMENT SUPPLIER/DESIGNER.
 3. SEE REFLECTED CEILING PLANS FOR LIGHTING AND POWER DIAGRAMS.

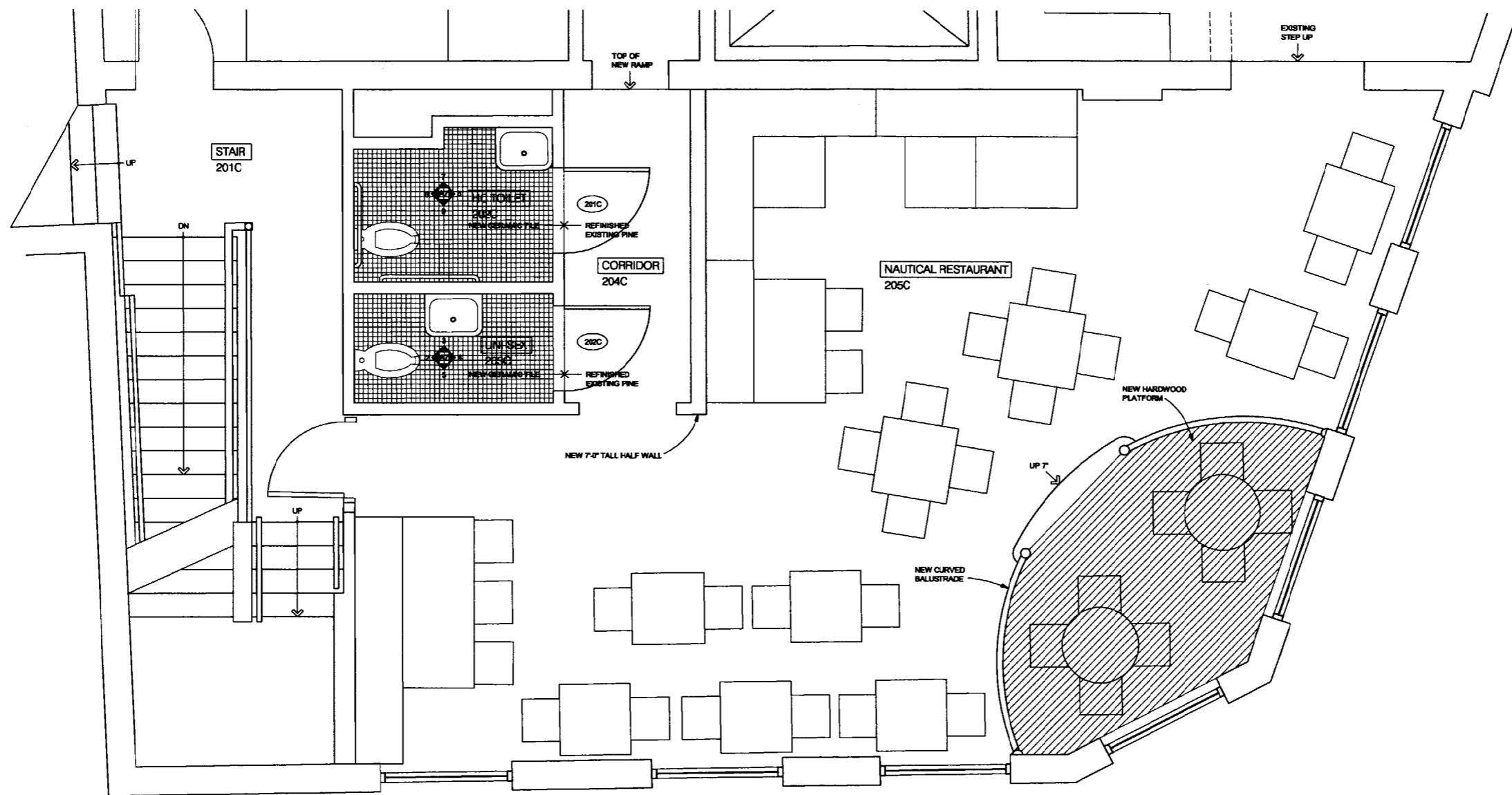

1
A-4

NEW SECOND FLOOR PLAN C-BAY

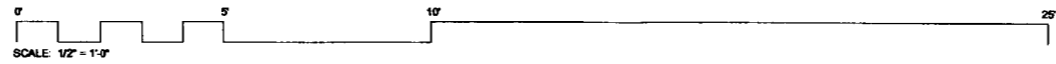

GENERAL NOTES:

1. FIXTURE AND APPLIANCE DIAGRAMS ARE SHOWN FOR LOCATIONAL PURPOSES ONLY. CONTRACTOR TO VERIFY DIMENSIONAL, PLUMBING, ELECTRICAL OR OTHER WORK REQUIRED TO ENABLE THE PROPER FUNCTIONING OF EACH COMPONENT.
2. ALL APPLICABLE CODE REQUIREMENTS REGARDING KITCHEN & BAR DESIGN AND EQUIPMENT REQUIREMENTS SHALL BE THE RESPONSIBILITY OF THE OWNER AND KITCHEN EQUIPMENT SUPPLIER/DESIGNER.
3. SEE REFLECTED CEILING PLANS FOR LIGHTING AND POWER DIAGRAMS.

Owner:
DOUGLAS FISS
GERARD HANO
HAND & FOOT, LLC
P.O. BOX 531
TEL. 207.773.7210

TURK TRACEY & LARRY
ARCHITECTS, LLC
82 EXCHANGE STREET
PORTLAND, MAINE 04101
TEL. 207.761.9882
FAX. 207.761.9896

Contractor:
WOODWARD THOMSEN CO.
30 PORTLAND STREET
PORTLAND, MAINE 04101
TEL. 207.774.9298
FAX. 207.774.0331

Rehabilitation of the Seaman's Club Building
BULL FEENEY'S IRISH PUB
375 FORE STREET
PORTLAND, MAINE

Date: 1 November 2001
Scale: As Shown
Revisions:

Title:
Progress
New Second Floor
Plan C-Bay
Sheet:
A-4

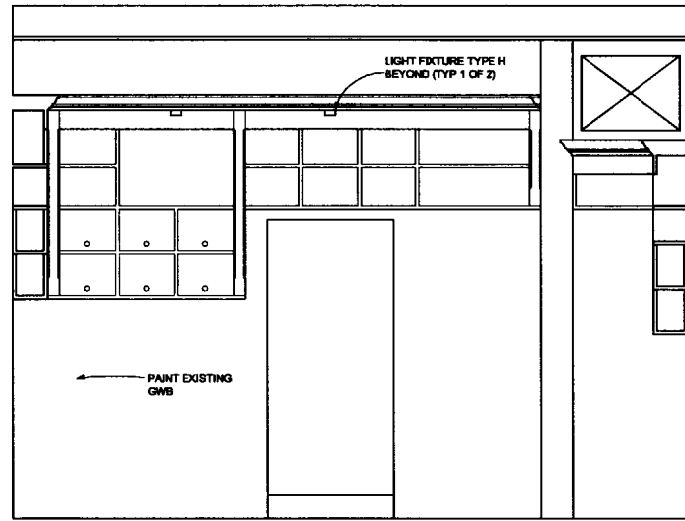

1 NORTH ELEVATION @ 1ST FLOOR ENTRY BAR
A-5 1/2" = 1'-0"

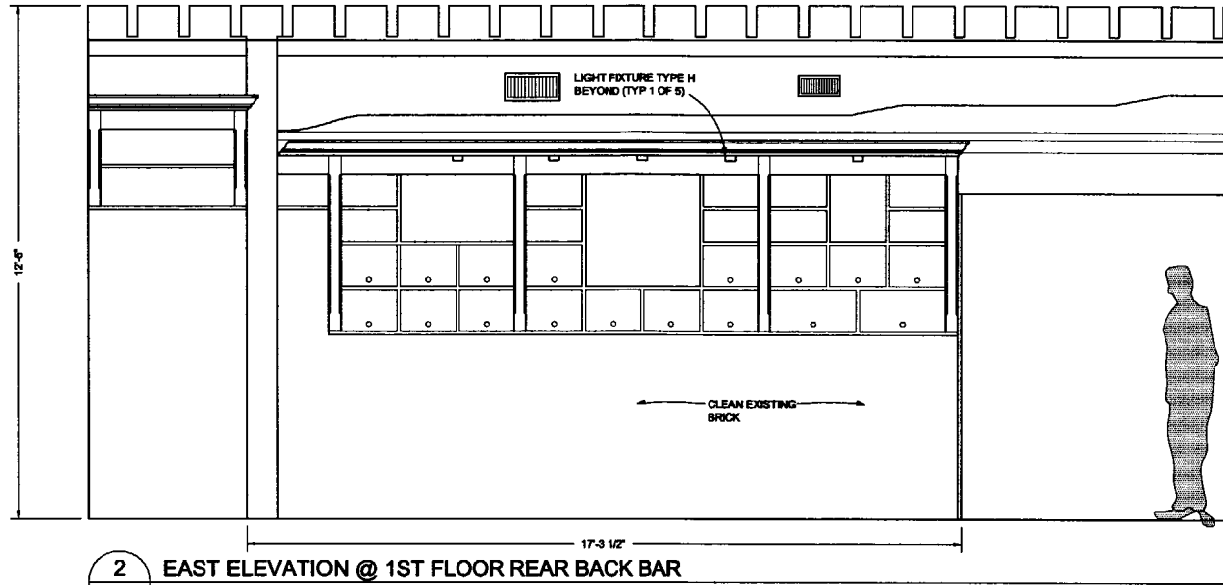

2 EAST ELEVATION @ 1ST FLOOR REAR BACK BAR
A-5 1/2" = 1'-0"

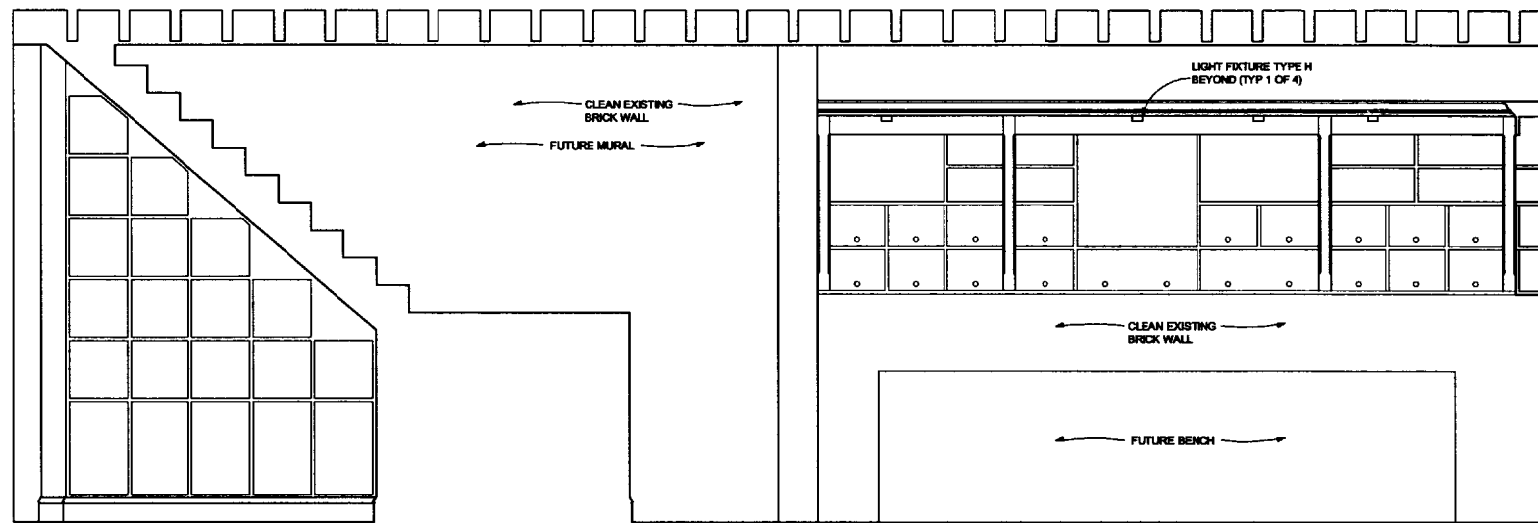

3 WEST ELEVATION @ 1ST FLOOR ENTRY BAR
A-5 1/2" = 1'-0"

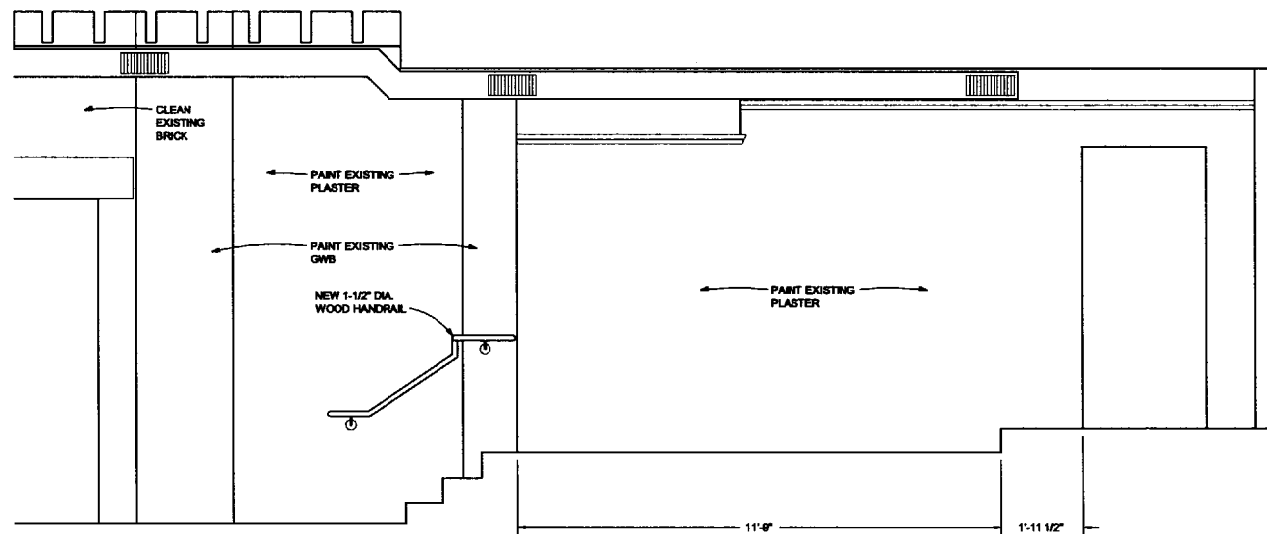

5 WEST ELEVATION @ COTTAGE BACK BAR
A-5 1/2" = 1'-0"

OWNER:
DOUGLAS FURS
GERARD HAND
HAND & FOOT, LLC
P.O. BOX 531
TEL. 207.773.7210

TURK TRACEY & LARRY
ARCHITECTS, LLC
92 EXCHANGE STREET
PORTLAND, MAINE 04101
TEL. 207.761.9892
FAX. 207.761.9896

Contractor:
WOODWARD THOMSEN CO.
50 PORTLAND STREET
PORTLAND, MAINE 04101
TEL. 207.774.8298
FAX. 207.774.0091

Rehabilitation of the Seamen's Club Building
BULL FEENEY'S IRISH PUB
 375 FORE STREET
 PORTLAND, MAINE

Date: 1 November 2001
Scale: As Shown
Revisions:

Title:
Progress
Interior Elevations
Details
Sheet: **A-5**

OWNER:
DOUGLAS FUSSELL
GERARD HAND
HAND & FOOT, LLC
P.O. BOX 891
TEL. 207.773.7210

ARCHITECTS:
TURK TRACEY & LARRY
ARCHITECTS, LLC
82 EXCHANGE STREET
PORTLAND, MAINE 04101
TEL. 207.761.9882
FAX. 207.761.9886

CONTRACTOR:
WOODWARD THOMSEN CO.
50 PORTLAND STREET
PORTLAND, MAINE 04101
TEL. 207.774.5288
FAX. 207.774.0081

Rehabilitation of the Seaman's Club Building
BULL FEENEY'S IRISH PUB
 375 FORE STREET
 PORTLAND, MAINE

Date: 1 November 2001
 Scale: As Shown
 Revisions:

Title:
 Progress
 Interior Elevations

Sheet:
A-6

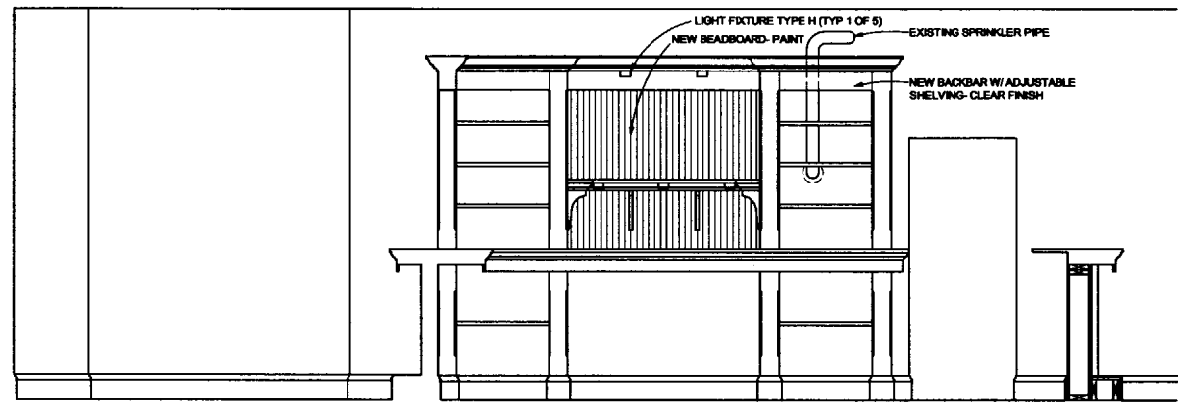

1 ELEVATION @ 2ND FLOOR COTTAGE BACK BAR
 A-6 1/2" = 1'-0"

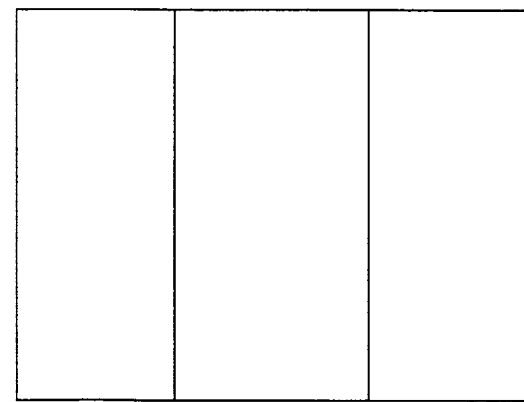

2 ELEVATION @ 2ND FLOOR TEA ROOM
 A-6 1/2" = 1'-0"

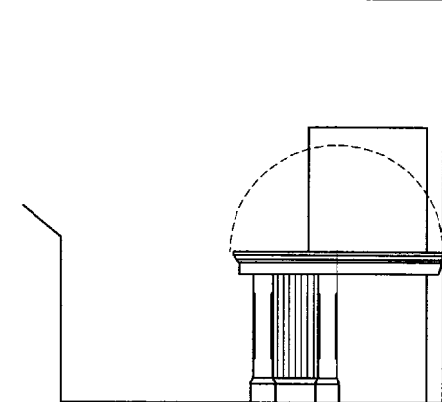

3 ELEVATION @ 2ND FLOOR TEA ROOM
 A-6 1/2" = 1'-0"

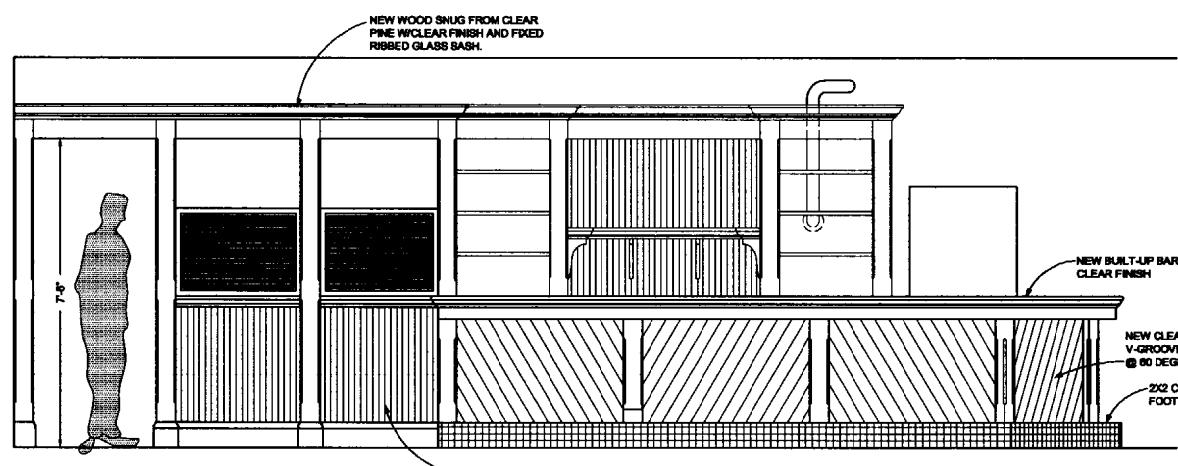

4 ELEVATION @ 2ND FLOOR COTTAGE BAR
 A-6 1/2" = 1'-0"

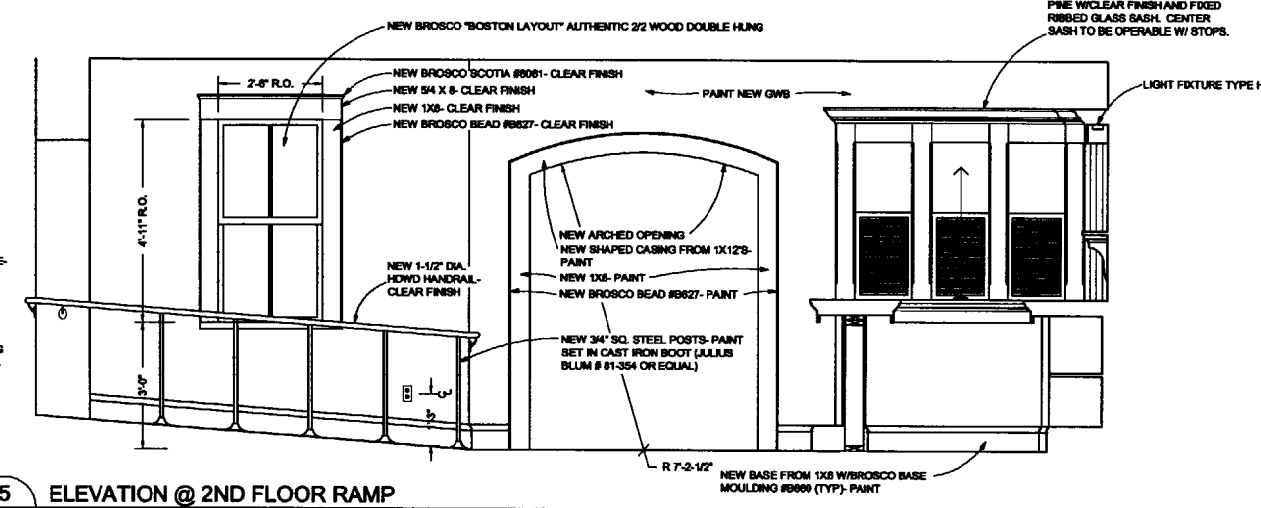

5 ELEVATION @ 2ND FLOOR RAMP
 A-6 1/2" = 1'-0"

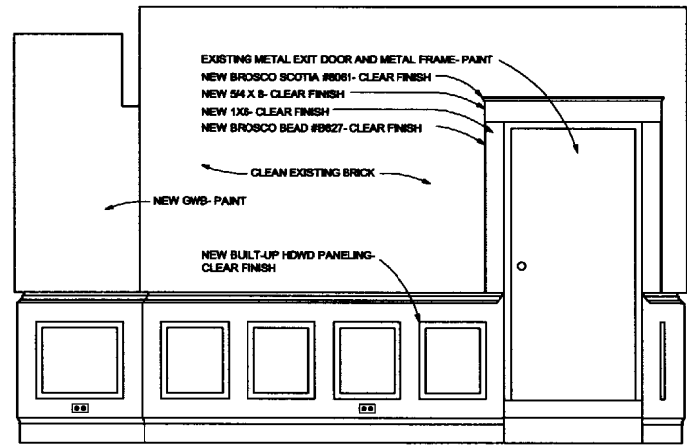

6 ELEVATION @ 2ND FLOOR LIBRARY ROOM
 A-6 1/2" = 1'-0"

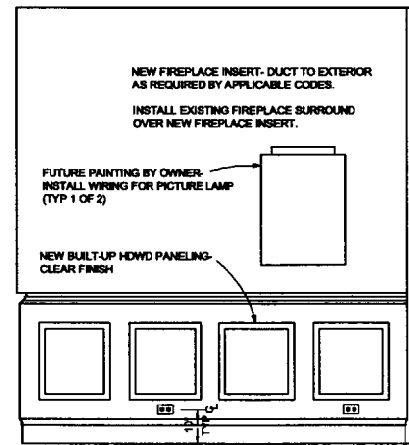

7 ELEVATION @ 2ND FLOOR LIBRARY ROOM
 A-6 1/2" = 1'-0"

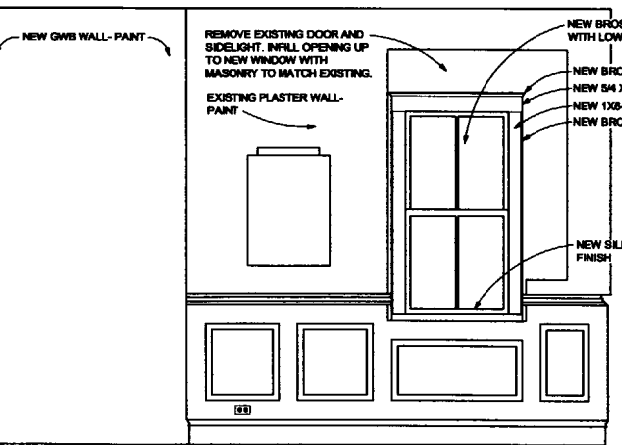

8 ELEVATION @ 2ND FLOOR LIBRARY ROOM
 A-6 1/2" = 1'-0"

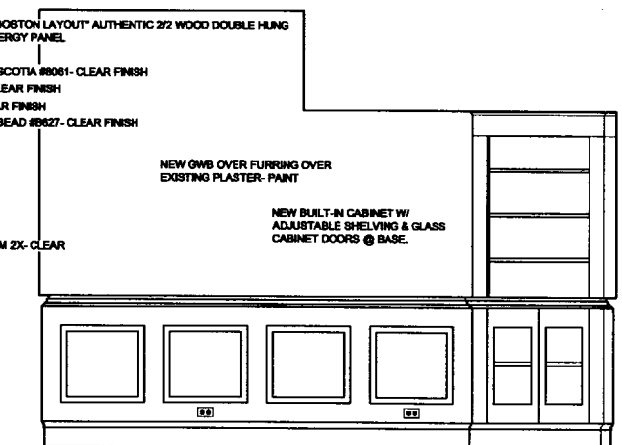

Owner:
DOUGLAS FUSS
GERARD HAWD
HAND & FOOT, LLC
P.O. BOX 531
TEL. 207.773.7210

ARCHITECTS:
TURK TRACEY & LARRY
ARCHITECTS, LLC
82 EXCHANGE STREET
PORTLAND, MAINE 04101
TEL. 207.781.8982
FAX. 207.781.8986

Contractor:
WOODWARD THOMSEN CO.
50 PORTLAND STREET
PORTLAND, MAINE 04101
TEL. 207.774.5298
FAX. 207.774.0031

Rehabilitation of the Seaman's Club Building
BULL FEENEY'S IRISH PUB
 375 FORE STREET
 PORTLAND, MAINE

Date: 1 November 2001
Scale: As Shown
Revisions:

Title:
Progress
Interior Elevations

Sheet:
A-7

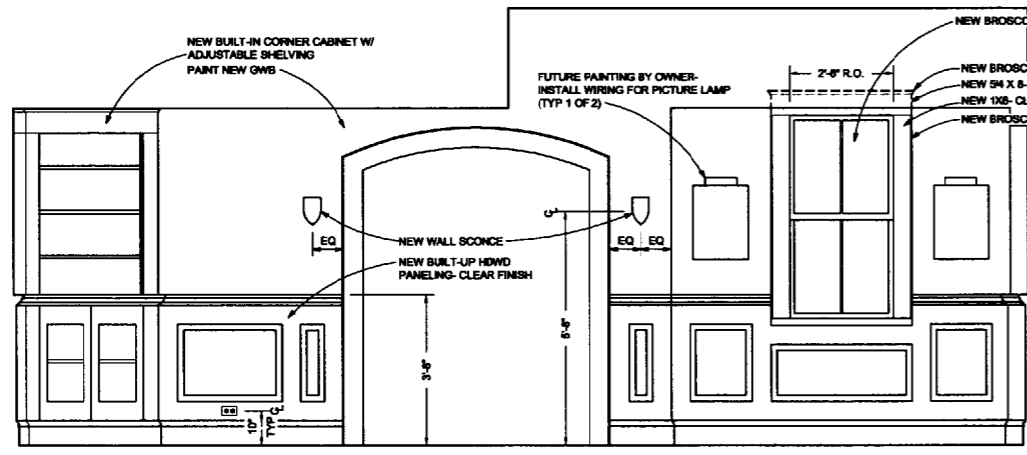

1 ELEVATION @ 2ND FLOOR LIBRARY ROOM
A-7 1/2" = 1'-0"

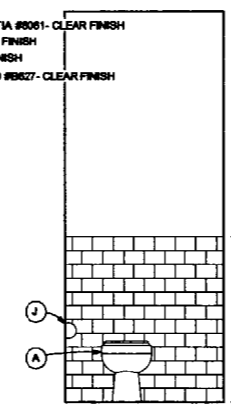

2 UNI-SEX 203C
A-7 1/2" = 1'-0"

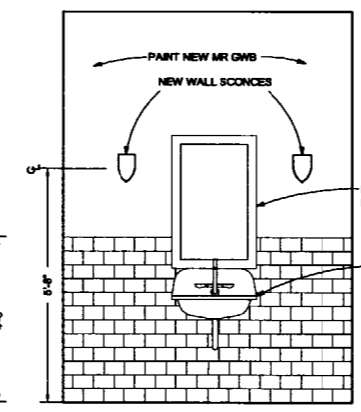

3 UNI-SEX 203C
A-7 1/2" = 1'-0"

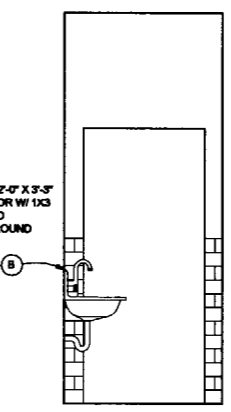

4 UNI-SEX 203C
A-7 1/2" = 1'-0"

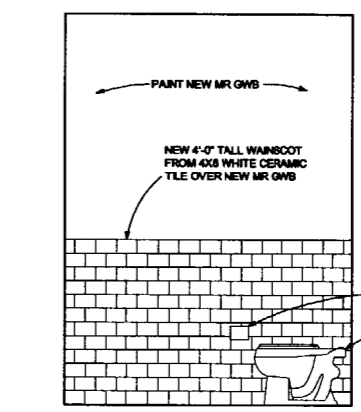

5 UNI-SEX 203C
A-7 1/2" = 1'-0"

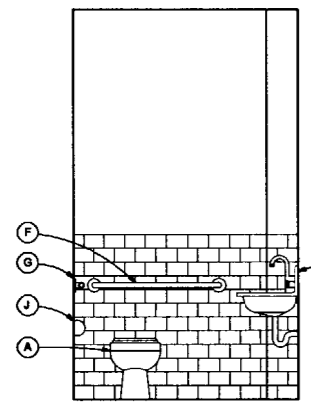

5 HC TOILET 202C
A-7 1/2" = 1'-0"

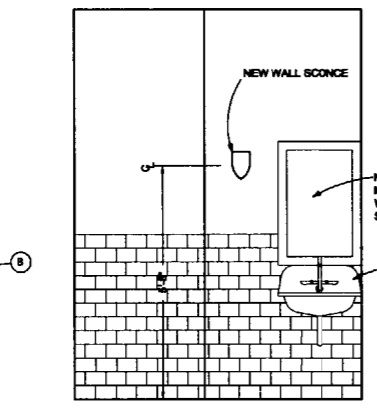

6 HC TOILET 202C
A-7 1/2" = 1'-0"

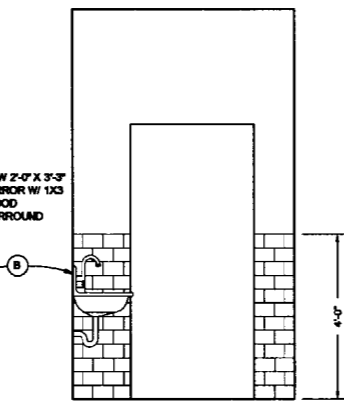

7 HC TOILET 202C
A-7 1/2" = 1'-0"

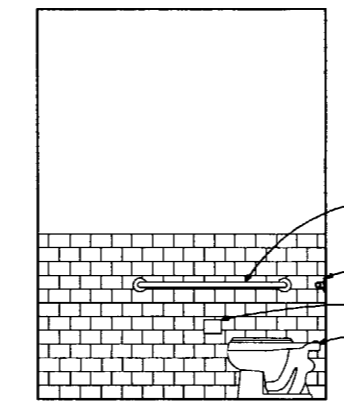

8 HC TOILET 202C
A-7 1/2" = 1'-0"

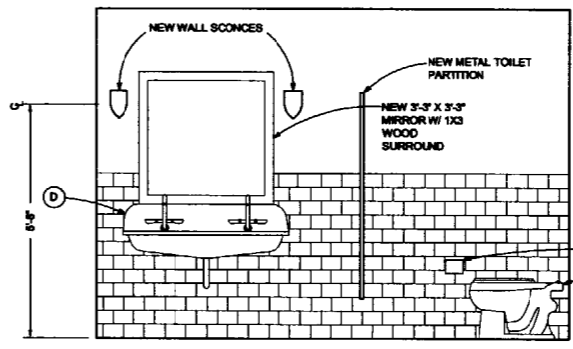

9 LADIES 105A
A-7 1/2" = 1'-0"

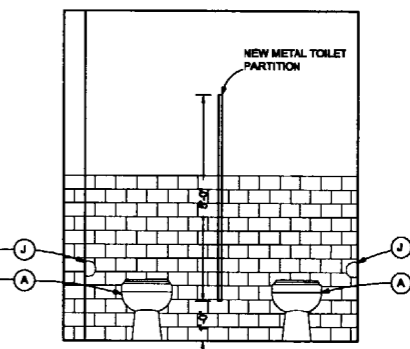

10 LADIES 105A
A-7 1/2" = 1'-0"

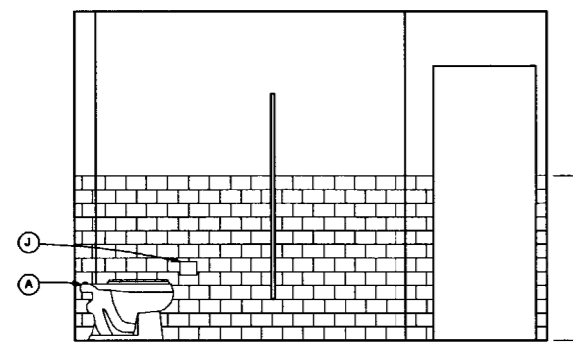

11 LADIES 105A
A-7 1/2" = 1'-0"

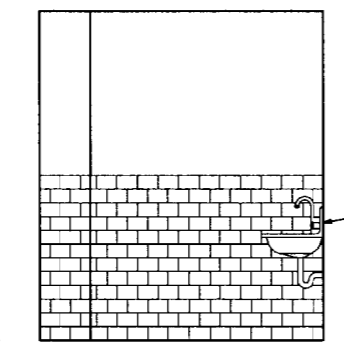

12 LADIES 105A
A-7 1/2" = 1'-0"

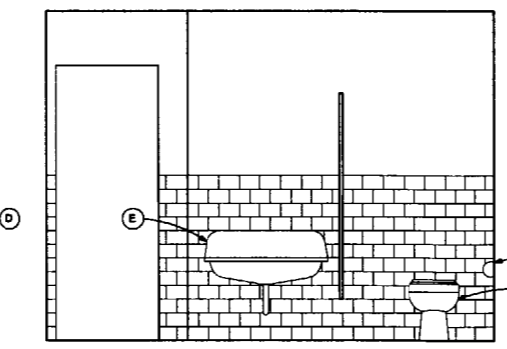

13 MEN 104A
A-7 1/2" = 1'-0"

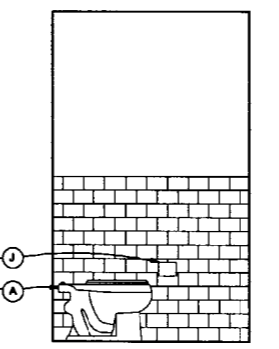

14 MEN 104A
A-7 1/2" = 1'-0"

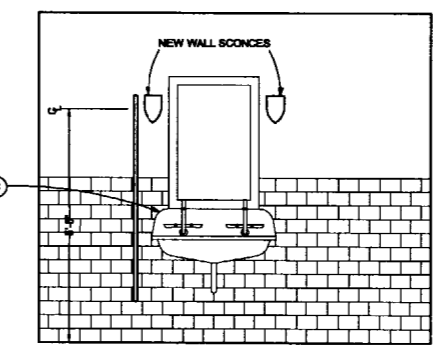

15 MEN 104A
A-7 1/2" = 1'-0"

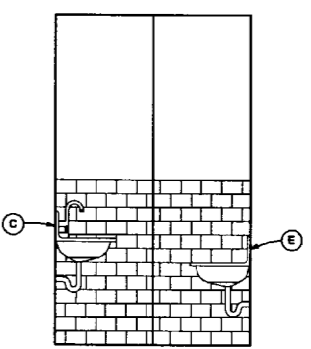

16 MEN 104A
A-7 1/2" = 1'-0"

- KEY
- (A) NEW ADA COMPLIANT TANKLESS TOILET, KOHLER #K-4302 "HIGHCREST" WITH LUSTRA ANTI-MICROBIAL SEAT #K-4302 "HIGHCREST", WHITE
 - (B) NEW SCRUB SINK, KOHLER #K-5680 "SUTTON" WITH TRITON FAUCET #K-13824
 - (C) NEW WALL MOUNT WALL SINK, KOHLER #K-3200 "BROCKWAY" WITH FAUCET #K-8862 & SOAP DISHES #K-8880
 - (D) NEW WALL MOUNT WALL SINK, KOHLER #K-3202 "BROCKWAY" WITH FAUCET #K-8862 & SOAP DISHES #K-8880
 - (E) NEW WALL HUNG URINAL, KOHLER #K-5055 "JARVES" WITH WASHDOWN PIPE #K-9198, P-TRAP #K-9000 & BEEHIVE STRAINER #K-9161
 - (F) NEW 36" GRABBAR BOBRICK #85806
 - (G) NEW 42" GRABBAR BOBRICK #85806
 - (H) NEW PAPER TOWEL DISPENSER BOBRICK #B36803
 - (J) NEW TOILET PAPER DISPENSER BOBRICK #B78857

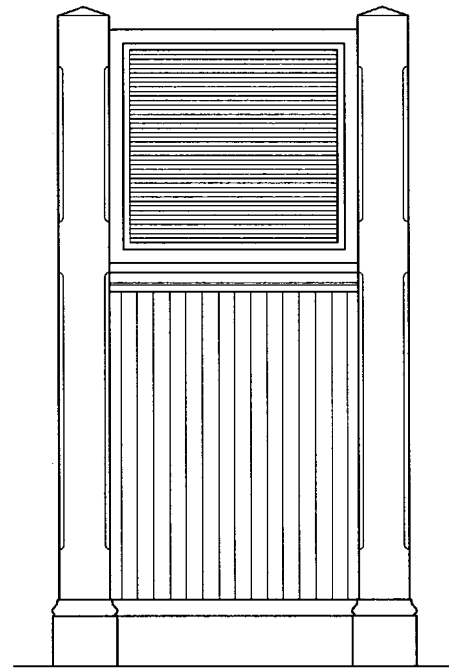

1 ELEVATION @ NEW SCREEN
A-8 1 1/2" = 1'-0"

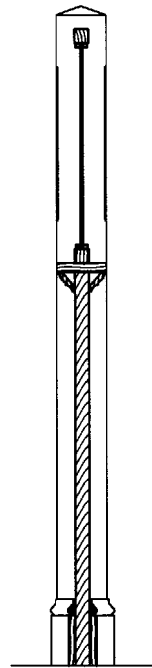

2 SECTION @ NEW SCREEN
A-8 1 1/2" = 1'-0"



3 SECTION @ DRINK SHELF
A-8 1 1/2" = 1'-0"

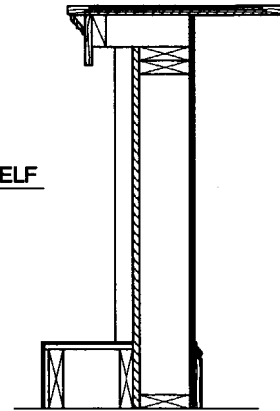

4 SECTION @ NEW BAR
A-8 1 1/2" = 1'-0"

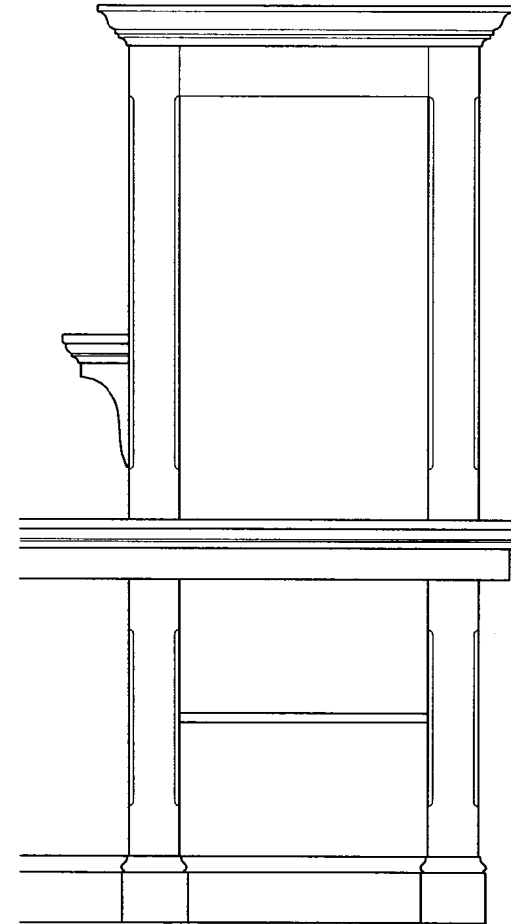

OWNER:
DOUGLAS FUSS
GERARD HAND
HAND & FOOT, LLC
P.O. BOX 531
TEL. 207.773.7210

TURK TRACEY & LARRY
ARCHITECTS, LLC
82 EXCHANGE STREET
PORTLAND, MAINE 04101
TEL. 207.751.8652
FAX. 207.751.9288

Contractor:
WOODWARD THOMSEN CO.
60 PORTLAND STREET
PORTLAND, MAINE 04101
TEL. 207.774.9298
FAX. 207.774.0031

Rehabilitation of the Seaman's Club Building
BULL FEENEY'S IRISH PUB
375 FORE STREET
PORTLAND, MAINE

Date: 1 November 2001
Scale: As Shown
Revisions:

Title:
Progress
Interior Details

Sheet:
A-8

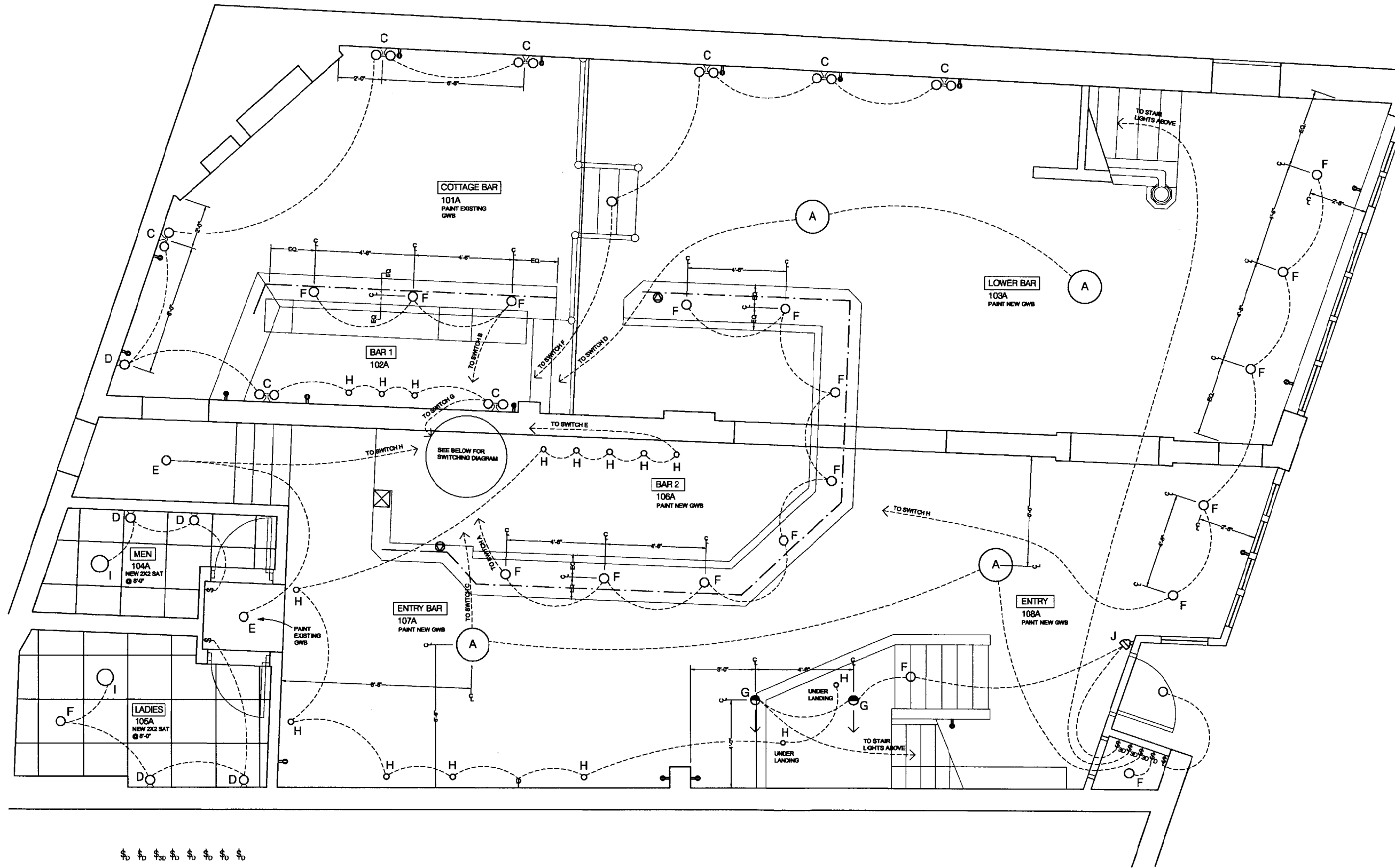

Ⓟ Ⓡ Ⓢ Ⓣ Ⓤ Ⓥ Ⓦ Ⓧ Ⓨ Ⓩ
 A B C D E F G H

SWITCHING DIAGRAM @ BAR 2



1
A-1

NEW FIRST FLOOR REFLECTED CEILING & POWER PLAN A-BAY



SCALE: 1/2" = 1'-0"
SEE SHEET A12 FOR LIGHT FIXTURE KEY

Owner:
 DOUGLAS FUSB
 GERARD HAWD
 HAND & FOOT, LLC
 P.O. BOX 531
 TEL. 207.773.7210

 TURK TRACEY & LARRY
 ARCHITECTS, LLC
 82 EXCHANGE STREET
 PORTLAND, MAINE 04101
 TEL. 207.761.9882
 FAX. 207.761.9886

 Contractor:
 WOODWARD THOMSEN CO.
 50 PORTLAND STREET
 PORTLAND, MAINE 04101
 TEL. 207.774.9298
 FAX. 207.774.0031

Rehabilitation of the Seaman's Club Building
BULL FEENEY'S IRISH PUB
 375 FORE STREET
 PORTLAND, MAINE

Date: 1 November 2001
 Scale: As Shown
 Revisions:

Title:
 Progress
 New First Floor
 RCP & Power Plan
 A-Bay
 Sheet:
A-9

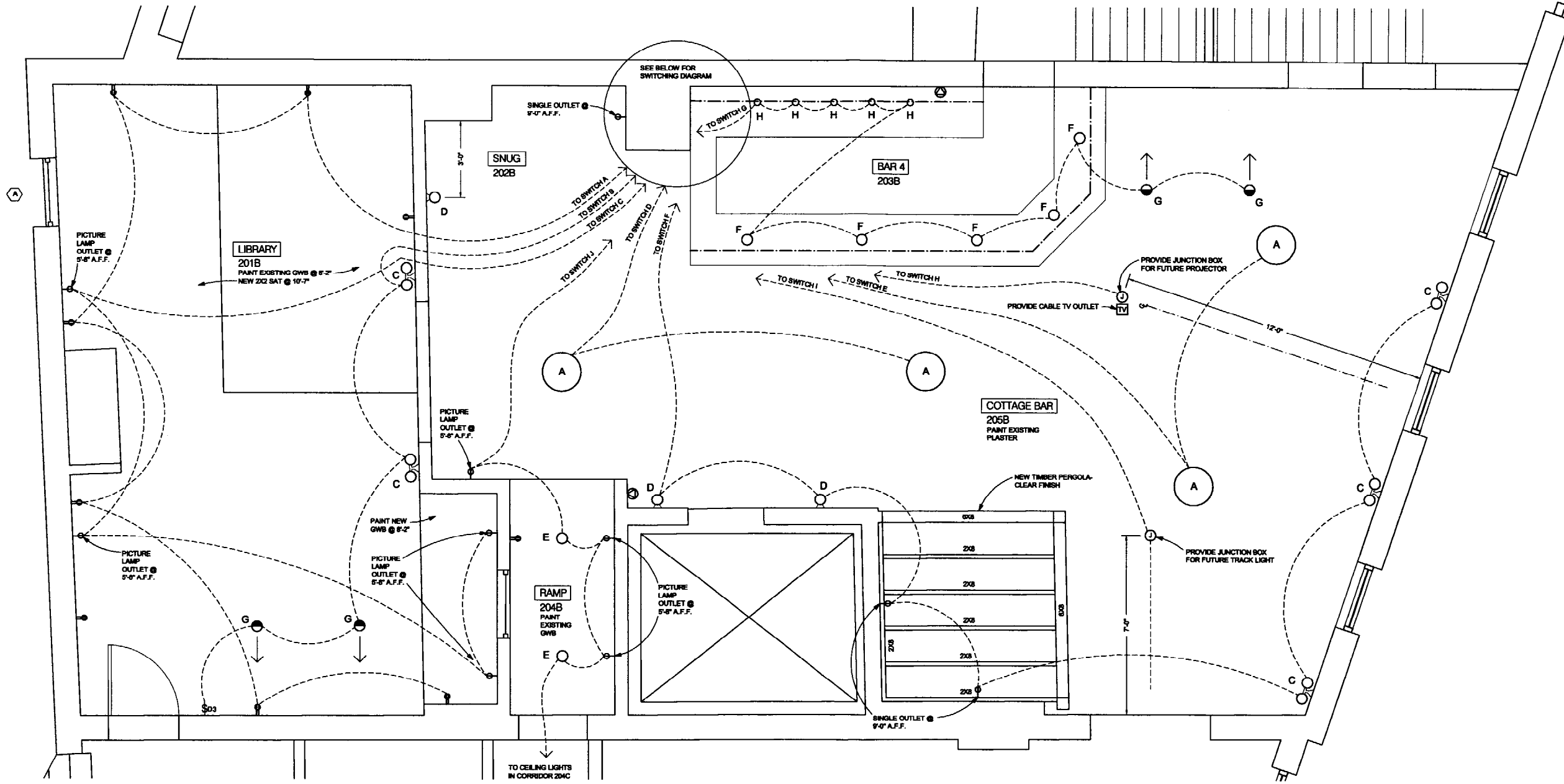

Ⓧ Ⓧ Ⓧ Ⓧ Ⓧ Ⓧ Ⓧ Ⓧ Ⓧ Ⓧ Ⓧ Ⓧ Ⓧ Ⓧ Ⓧ Ⓧ
A B C D E F G H I J K L M N
SWITCHING DIAGRAM @ BAR 4

N
1
A-11
NEW SECOND FLOOR REFLECTED CEILING PLAN & POWER PLAN B-BAY

SCALE: 1/2" = 1'-0"

SEE SHEET A12 FOR LIGHT FIXTURE KEY

Owner:
DOUGLAS FUSSELL
GERARD HAND
HAND & FOOT, LLC
P.O. BOX 531
TEL. 207.773.7210

TURK TRACEY & LARRY
ARCHITECTS, LLC
82 EXCHANGE STREET
PORTLAND, MAINE 04101
TEL. 207.781.9882
FAX. 207.781.9886

Contractor:
WOODWARD THOMSEN CO.
80 PORTLAND STREET
PORTLAND, MAINE 04101
TEL. 207.774.9296
FAX. 207.774.0031

Rehabilitation of the Seaman's Club Building

BULL FEENEY'S IRISH PUB

375 FORE STREET
PORTLAND, MAINE

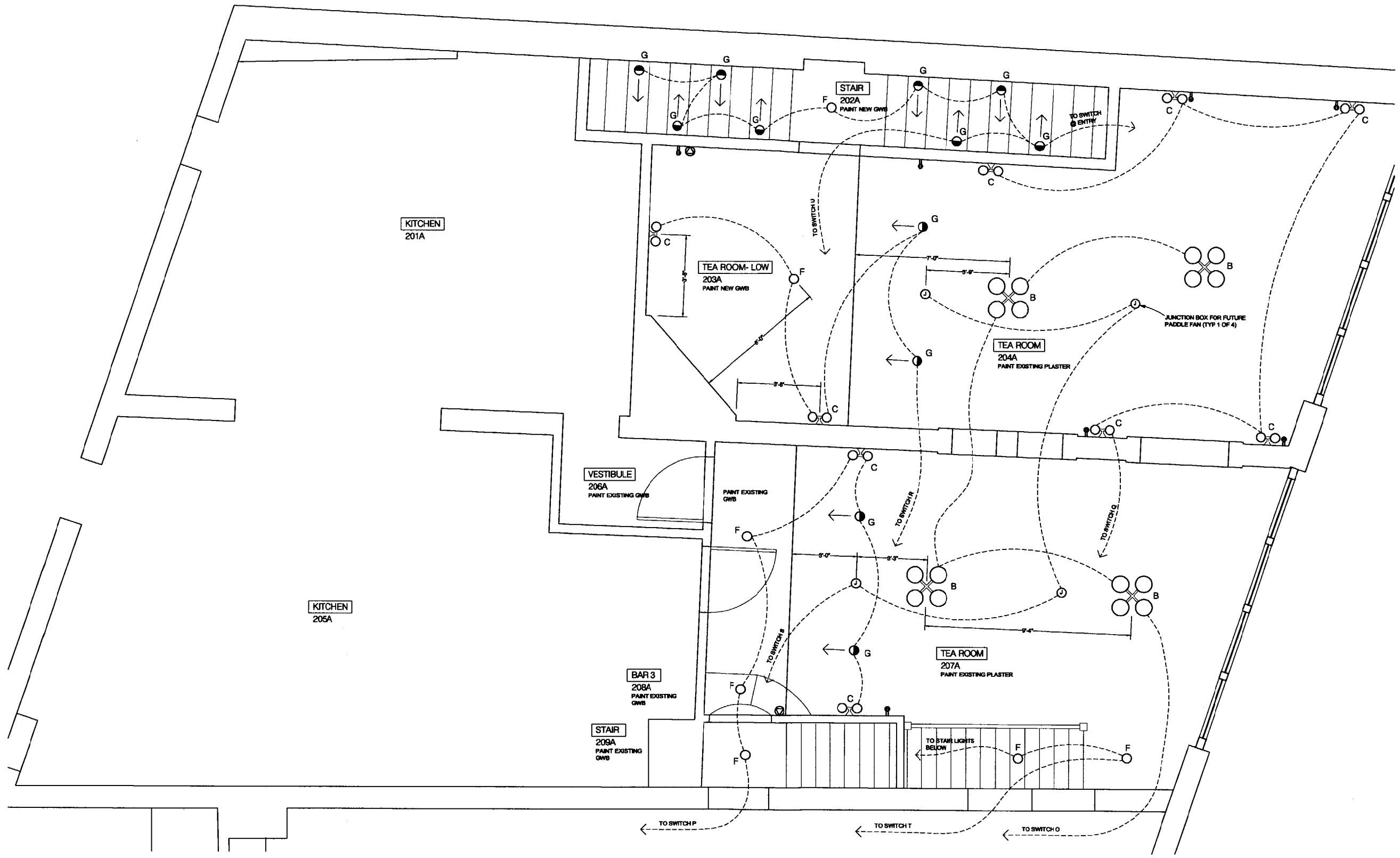

Date: 1 November 2001
Scale: As Shown
Revisions:



Title:
Progress
New Second Floor
RCP & Power Plan
A-Bay
Sheet:
A-10

N 1
A-10 **NEW SECOND FLOOR REFLECTED CEILING PLAN & POWER PLAN A-BAY**

0 5 10 20
SCALE: 1/2" = 1'-0"

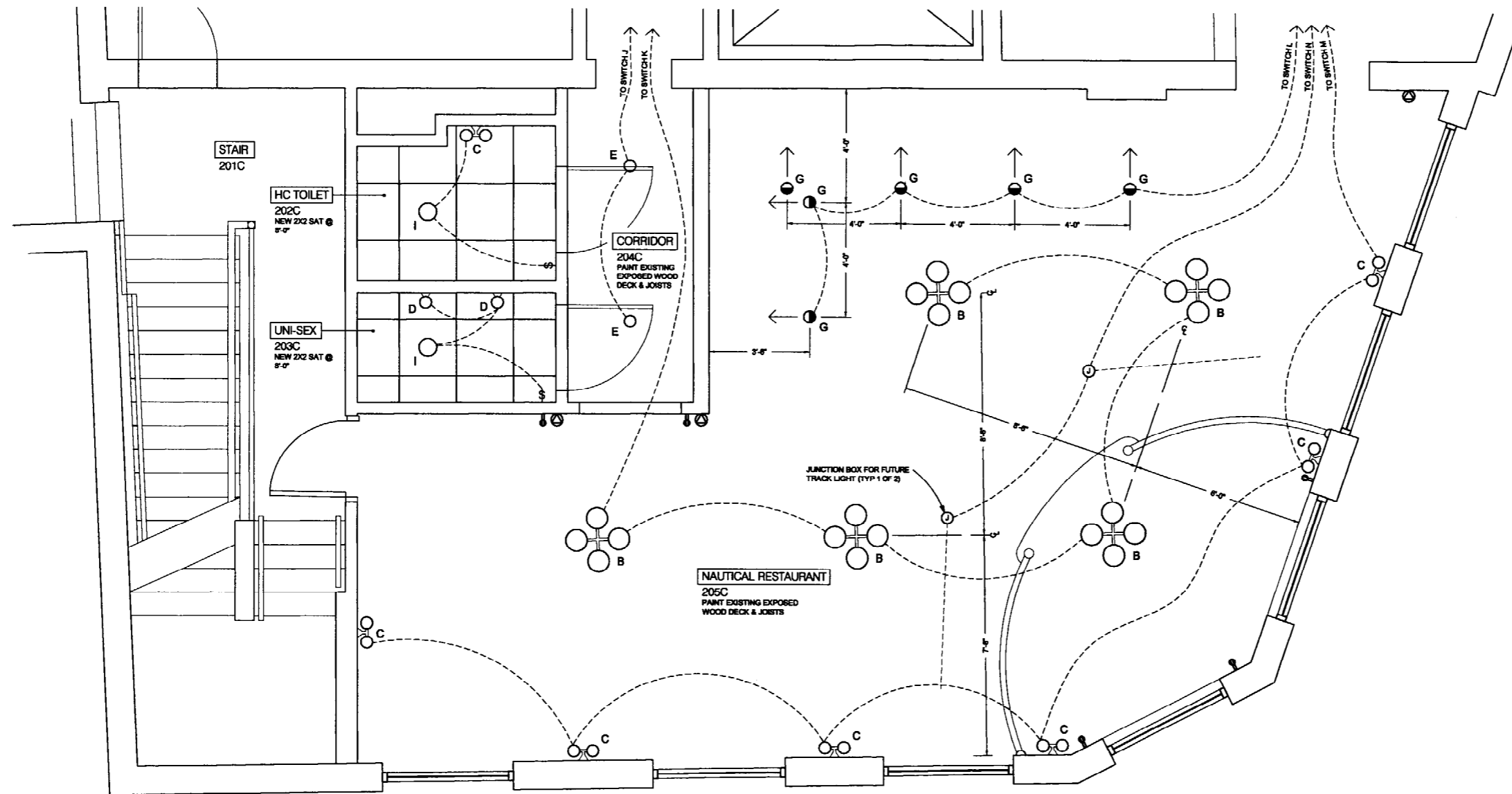
SEE SHEET A12 FOR LIGHT FIXTURE KEY





NEW SECOND FLOOR REFLECTED CEILING PLAN & POWER PLAN C-BAY
 SCALE: 1/2" = 1'-0"

LIGHT FIXTURE KEY

- A "SCHOOLHOUSE" PENDANT FIXTURE
- B "FOUR-LIGHT" PENDANT FIXTURE
- C "TWO-LIGHT" SCONCE
- D "ONE-LIGHT" SCONCE
- E SURFACE MOUNTED CEILING FIXTURE
- F RECESSED DOWNLIGHT W/STEP BAFFLE. "LIGHTOLIER" #1105/1103R AR19
- G RECESSED WALLWASHER W/STEP BAFFLE. "LIGHTOLIER" #1135/1103R A19
- H LOW-VOLTAGE UNDERCABINET DISK LIGHT
- I CEILING FAN. ATTACH TO EXISTING DUCTWORK.
- J ENCLOSED SPOT LIGHT "LIGHTOLIER" #8273B.

OWNER:
 DOUGLAS FURS
 GERARD HAND
 HAND & FOOT, LLC
 P.O. BOX 531
 TEL. 207.773.7210

 TURK TRACEY & LARRY
 ARCHITECTS, LLC
 92 EXCHANGE STREET
 PORTLAND, MAINE 04101
 TEL. 207.761.5862
 FAX. 207.761.8886

 Contractor:
 WOODWARD THOMSEN CO.
 80 PORTLAND STREET
 PORTLAND, MAINE 04101
 TEL. 207.774.9298
 FAX. 207.774.0051

Rehabilitation of the Seamen's Club Building
BULL FEENEY'S IRISH PUB
 375 FORE STREET
 PORTLAND, MAINE

Date: 1 November 2001
 Scale: As Shown
 Revisions:

Title:
 Progress
 New Second Floor
 RCP & Power Plan
 C-Bay
 Sheet: **A-12**