

City of Portland, Maine - Building or Use Permit Application

389 Congress Street, 04101 Tel: (207) 874-8703, Fax: (207) 874-8716

Permit No: 05-0202	Issue Date: JAN 14 2005	BL: 032 E010001
05-0202	PERMIT ISSUED	
Owner Name: Milk Street Group Llc	Owner Address: 25 Pearl St	Phone:
Business Name:	Contractor Name: conley enterprises	Contractor Address: 33 Pismire Mtn Rd, Raymond
Lessee/Buyer's Name	Phone:	Permit Type: HVAC
		Zone: B3

Past Use: commercial - <i>in restaurant</i>	Proposed Use: commercial install an American Standard/Trane furnace - <i>in restaurant</i>	Permit Fee: \$30.00	Cost of Work: \$1,000.00	CEO District: 1	
		FIRE DEPT: <input checked="" type="checkbox"/> Approved <input type="checkbox"/> Denied	INSPECTION: Use Group: B Type: HVAC		
Proposed Project Description: Install an American Standard/Trane furnace		Signature: <i>[Signature]</i>	Signature: <i>JMB 1/13/05</i>		
		PEDESTRIAN ACTIVITIES DISTRICT (P.A.D.)			
		Action: <input type="checkbox"/> Approved <input type="checkbox"/> Approved w/Conditions <input type="checkbox"/> Denied			
		Signature: _____ Date: _____			

Permit Taken By: dmartin	Date Applied For: 01/03/2005	Zoning Approval		
<p>1. This permit application does not preclude the Applicant(s) from meeting applicable State and Federal Rules.</p> <p>2. Building permits do not include plumbing, septic or electrical work.</p> <p>3. Building permits are void if work is not started within six (6) months of the date of issuance. False information may invalidate a building permit and stop all work..</p>	Special Zone or Reviews <input type="checkbox"/> Shoreland <input type="checkbox"/> Wetland <input type="checkbox"/> Flood Zone <input type="checkbox"/> Subdivision <input type="checkbox"/> Site Plan Maj <input type="checkbox"/> Minor <input type="checkbox"/> MM <input type="checkbox"/> Date: <i>1/13/05</i>	Zoning Appeal <input type="checkbox"/> Variance <input type="checkbox"/> Miscellaneous <input type="checkbox"/> Conditional Us <input type="checkbox"/> Interpretation <input type="checkbox"/> Approved <input type="checkbox"/> Denied Date: _____	Historic Preservation <input checked="" type="checkbox"/> Not in District or Landmark <input checked="" type="checkbox"/> Does Not Require Review <input type="checkbox"/> Requires Review <input type="checkbox"/> Approved <input type="checkbox"/> Approved w/Conditions <input type="checkbox"/> Denied Date: <i>NA JMB</i>	

CERTIFICATION

I hereby certify that I am the owner of record of the named property, or that the proposed work is authorized by the owner of record and that I have been authorized by the owner to make this application as his authorized agent and I agree to conform to all applicable laws of this jurisdiction. In addition, if a permit for work described in the application is issued, I certify that the code official's authorized representative shall have the authority to enter all areas covered by such permit at any reasonable hour to enforce the provision of the code(s) applicable to such permit.

SIGNATURE OF APPLICANT	ADDRESS	DATE	PHONE
RESPONSIBLE PERSON IN CHARGE OF WORK. TITLE		DATE	PHONE

City of Portland, Maine - Building or Use Permit Application

389 Congress Street, 04101 Tel: (207) 874-8703, Fax: (207) 874-8716

Permit No: 05- 02	Issue Date: PERMIT ISSUED JAN 14 2005	LBL: 032 E010001
----------------------	--	---------------------

Location of Construction: 46 Market St	Dwner Name: Milk Street Group Llc	Owner Address: 25 Pearl St	Phone:
Business Name:	Contractor Name: conley enterprises	Contractor Address: 33 Pismire Mtn Rd Raymond	Phone: 2076552890
Tenant/Buyer's Name	Phone:	Permit Type: HVAC	Zone: B3

Past Use: commercial - restaurant	Proposed Use: commercial install an American Standard/Trane furnace - in rest	Permit Fee: \$30.00	Cost of Work: \$1,000.00	CEO District: 1
		FIRE DEPT: <input checked="" type="checkbox"/> Approved <input type="checkbox"/> Denied	INSPECTION: Use Group: B Type: HVAC	

Proposed Project Description: Install an American Standard/Trane furnace	Signature: <i>[Signature]</i>	Signature: <i>JMB 1/13/05</i>
PEDESTRIAN ACTIVITIES DISTRICT (P.A.D.)		
Action: <input type="checkbox"/> Approved <input type="checkbox"/> Approved w/Conditions <input type="checkbox"/> Denied		
Signature: _____ Date: _____		

Permit Taken By: dmartin	Date Applied For: 01/03/2005	Zoning Approval	
------------------------------------	--	------------------------	--

<p>1.</p> <p>2. Building permits do not include plumbing, septic or electrical work.</p> <p>3. Building permits are void if work is not started within six (6) months of the date of issuance. False information may invalidate a building permit and stop all work..</p>	Special Zone or Reviews <input type="checkbox"/> Shoreland <input type="checkbox"/> Wetland <input type="checkbox"/> Flood Zone <input type="checkbox"/> Subdivision <input type="checkbox"/> Site Plan Maj <input type="checkbox"/> Minor <input type="checkbox"/> MM <input type="checkbox"/> Date: <i>1/13/05</i>	Zoning Appeal <input type="checkbox"/> Variance <input type="checkbox"/> Miscellaneous <input type="checkbox"/> Conditional Use <input type="checkbox"/> Interpretation <input type="checkbox"/> Approved <input type="checkbox"/> Denied Date: _____	Historic Preservation <input checked="" type="checkbox"/> Not in District or Landmark <input checked="" type="checkbox"/> Does Not Require Review <input type="checkbox"/> Requires Review <input type="checkbox"/> Approved <input type="checkbox"/> Approved w/Conditions <input type="checkbox"/> Denied Date: <i>NA JMB</i>
---	--	---	---

CERTIFICATION

I hereby certify that I am the owner of record of the named property, or that the proposed work is authorized by the owner of record and that I have been authorized by the owner to make this application as his authorized agent and I agree to conform to all applicable laws of this jurisdiction. In addition, if a permit for work described in the application is issued, I certify that the code official's authorized representative shall have the authority to enter all areas covered by such permit at any reasonable hour to enforce the provision of the code(s) applicable to such permit.

SIGNATURE OF APPLICANT	ADDRESS	DATE	PHONE
RESPONSIBLE PERSON IN CHARGE OF WORK, TITLE		DATE	PHONE

City of Portland, Maine - Building or Use Permit

389 Congress Street, 04101 Tel: (207) 874-8703, Fax: (207) 874-8716

Permit No: 05-0002	Date Applied For: 01/03/2005	CBL: 032 E010001
------------------------------	--	----------------------------

Location of Construction: 46 Market St	Owner Name: Milk Street Group Llc	Owner Address: 25 Pearl St	Phone:
Business Name:	Contractor Name: conley enterprises	Contractor Address: 33 Pismire Mtn Rd Raymond	Phone (207) 655-2890
Lessee/Buyer's Name	Phone:	Permit Type: HVAC	

Proposed Use: commercial install an American Standard/Trane furnace	Proposed Project Description: Install an American Standard/Trane furnace
---	--

Dept: Zoning **Status:** Approved **Reviewer:** Marge Schmuckal **Approval Date:** 01/13/2005

Note: **Ok to Issue:**

Dept: Building **Status:** Approved **Reviewer:** Jeanine Bourke **Approval Date:** 01/13/2005

Note: 1/13/05 gave to Marge for zoning review **Ok to Issue:**

1) The installation must comply with the State of Maine Gas Regulations.

Dept: Fire **Status:** Approved with Conditions **Reviewer:** Lt. MacDougal **Approval Date:** 01/11/2005

Note: **Ok to Issue:**

1) furnace shall be installed in accordance with the manufacturers recommendation



FILL IN AND SIGN WITH INK

APPLICATION FOR PERMIT HEATING OR POWER EQUIPMENT

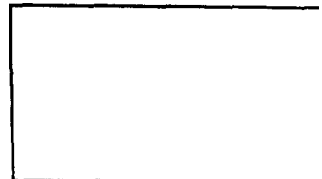

To the INSPECTOR OF BUILDINGS, PORTLAND, ME.

The undersigned hereby applies for a permit to install the following heating, cooking or power equipment in accordance with the Laws of Maine, the Building Code of the City of Portland, and the following specifications:

Location / CBL 46 MARKET ST. Use of Building RESTURANT Date 12/30/
 Name and address of owner of appliance Milk St. Group LLC
25 PEARL ST, 3rd floor, Portland 04101
 Installer's name and address MARK CONLEY (CONLEY ENTERPRISES) 33 PISMIRE MTN Rd.
RAYMOND, ME 04071 Telephone 207 655 2890

Location of appliance:

- Basement Floor
 Attic Roof

Type of Fuel:

- Gas Oil Solid

Appliance Name: American Standard / TRANE

U.L. Approved Yes No

Will appliance be installed in accordance with the manufacture's installation instructions? Yes No

IF NO Explain: _____

The Type of License of Installer:

- Master Plumber # _____
 Solid Fuel # _____
 Oil # PN1725
 Gas # _____
 Other _____

Type of Chimney:

- Masonry Lined
 Factory built _____

- Metal
 Factory Built U.L. Listing # _____

- Direct Vent PVC VENT INTO A TERMINATION
 Type _____ UL# _____
KIT 200B

Type of Fuel Tank

- Oil
 Gas

Size of Tank STREET SUPPLIED

Number of Tanks _____

Distance from Tank to Center of Flame _____ feet.

Cost of Work: \$ 1000

Permit Fee: \$ 30.00

Approved

Fire: [Signature]
 Ele.: _____
 Bldg.: [Signature]

Approved with Conditions

- See attached letter or requirement

Inspector's Signature

Date Approved

Signature of Installer _____

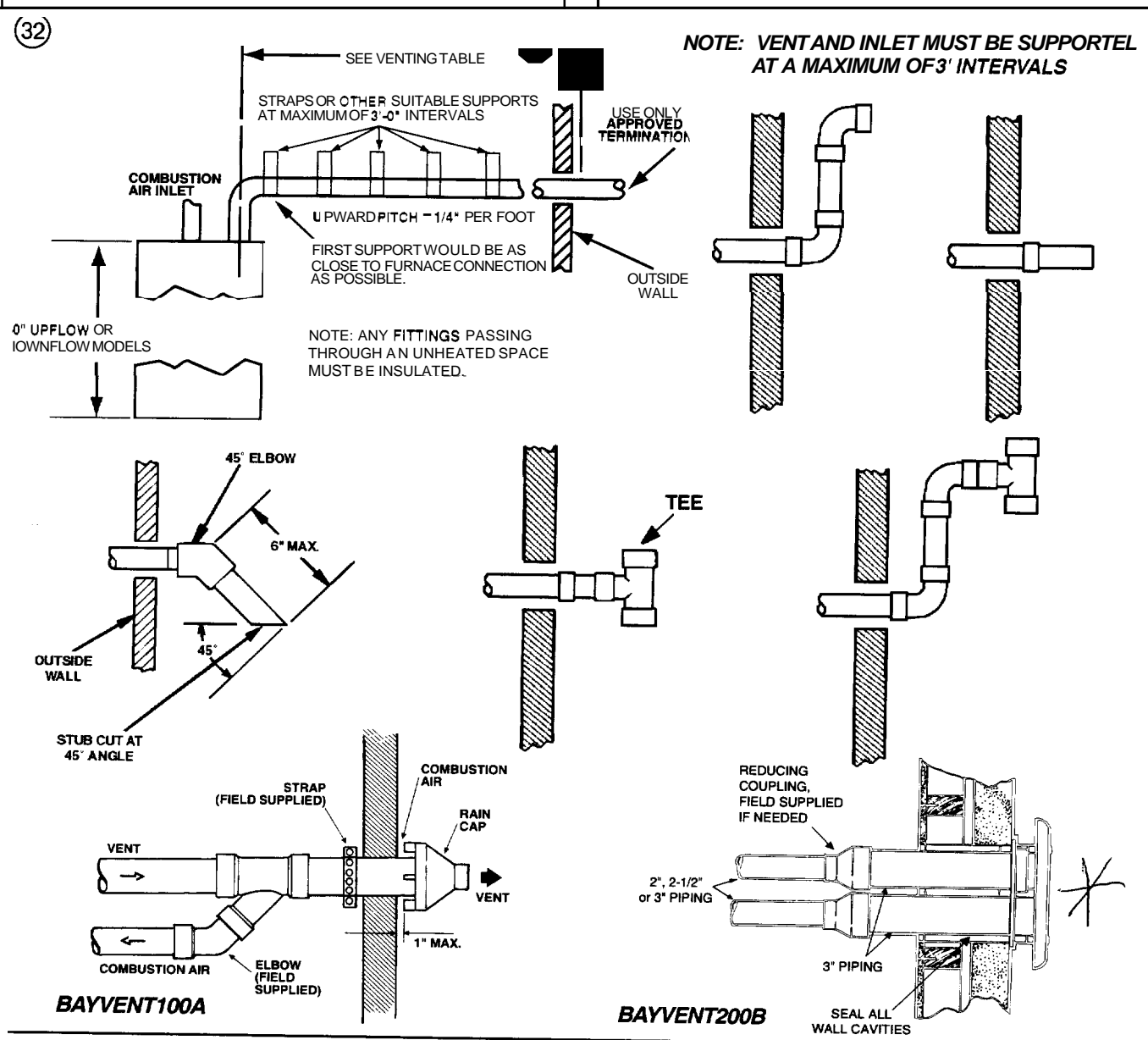
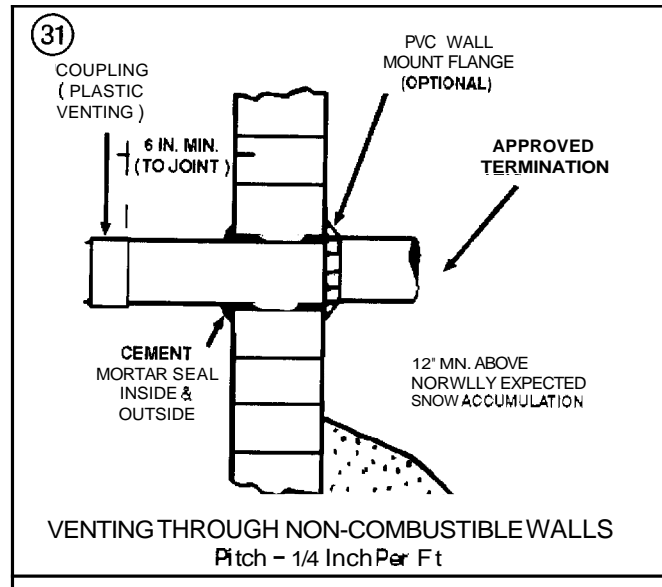
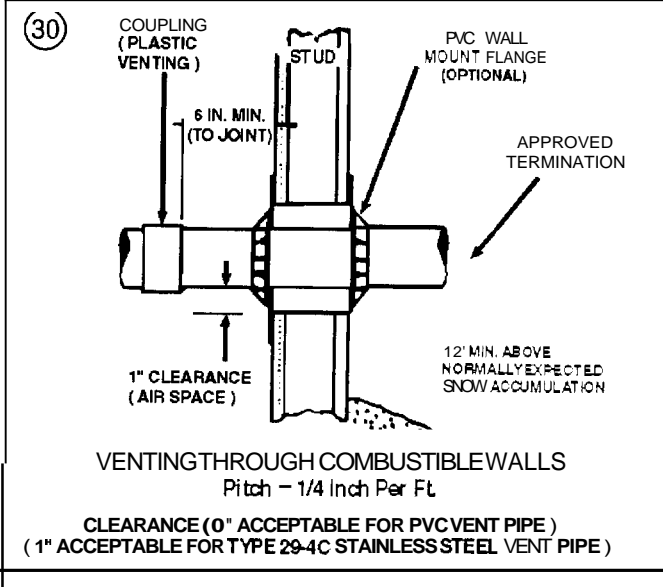

46 MARKET BASEMENT VENTING

WXP10C 960

BAR AREA

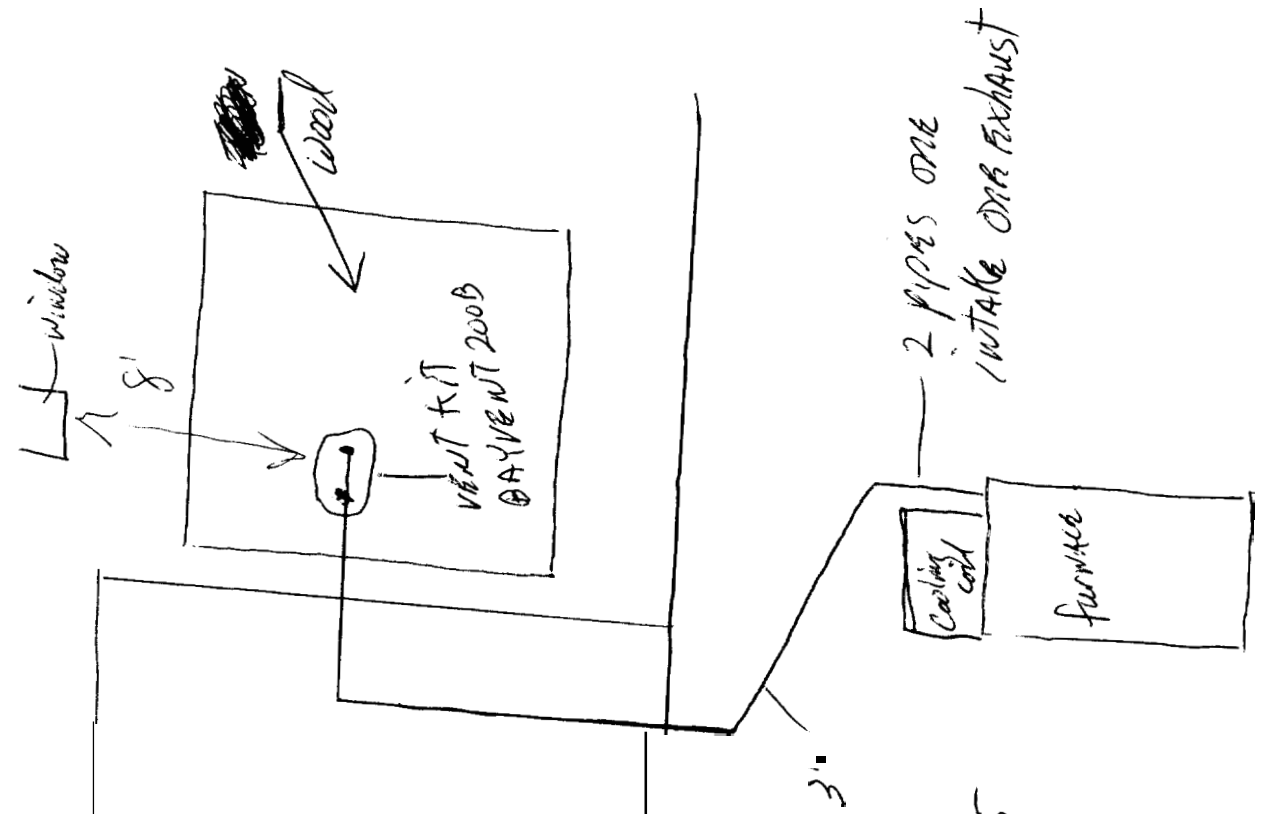

Unit is 100,000 BTU FURNACE

RETURNS PAGE 15 of MANUAL

TOTAL run is approximately 35' with 2 3" 45

AND 2 90° elbows (long sweep)