

City of Portland, Maine - Building or Use Permit Application

389 Congress Street, 04101 Tel: (207) 874-8703, FAX: (207) 8716

Job No: 2012-10-5193-CH-OF-USE <i>USE 2012-49305</i>	Date Applied: 10/16/2012	CBL: 032- E-004-001	
Location of Construction: 49 EXCHANGE ST (64 Market St)	Owner Name: ALBERT PALACCI	Owner Address: 4761 BROADWAY NEW YORK, NY 10034	Phone: 207-772-8107
Business Name:	Contractor Name: Benjamin Downs	Contractor Address: 68 Fellows St., South Portland ME 04106	Phone: (207)749-8235
Lessee/Buyer's Name: Darren Thomas	Phone: 207-671-5524	Permit Type: BLDG - Building	Zone: B-3
Past Use: Storage	Proposed Use: Restaurant (more than 9 seats & book store - change of use - tenant fit up	Cost of Work: 5000.00	CEO District:
		Fire Dept: <i>2/28/13</i> <input checked="" type="checkbox"/> Approved <input type="checkbox"/> Denied <input type="checkbox"/> N/A Signature: <i>Bjornald</i> (58)	Inspection: Use Group: <i>M</i> Type: <i>3B</i> <i>MUSEC '09</i> Signature: <i>JMB 1/29/13</i>
Proposed Project Description: Change of Use from Storage to Restuarant/Book Store		Pedestrian Activities District (P.A.D.)	

Permit Taken By: Lannie	Zoning Approval		
<p>1. This permit application does not preclude the Applicant(s) from meeting applicable State and Federal Rules.</p> <p>2. Building Permits do not include plumbing, septic or electrical work.</p> <p>3. Building permits are void if work is not started within six (6) months of the date of issuance. False informatin may invalidate a building permit and stop all work.</p>	Special Zone or Reviews <input type="checkbox"/> Shoreland <input type="checkbox"/> Wetlands <input type="checkbox"/> Flood Zone <input type="checkbox"/> Subdivision <input type="checkbox"/> Site Plan <input type="checkbox"/> Maj <input type="checkbox"/> Min <input type="checkbox"/> MM Date: <i>Okul condition 10/16/12 JMB</i>	Zoning Appeal <input type="checkbox"/> Variance <input type="checkbox"/> Miscellaneous <input type="checkbox"/> Conditional Use <input type="checkbox"/> Interpretation <input type="checkbox"/> Approved <input type="checkbox"/> Denied Date:	Historic Preservation <input type="checkbox"/> Not in Dist or Landmark <input type="checkbox"/> Does not Require Review <input type="checkbox"/> Requires Review <input type="checkbox"/> Approved <input checked="" type="checkbox"/> <i>See HP PERMIT</i> <input type="checkbox"/> Approved w/Conditions <input type="checkbox"/> Denied Date: <i>Any exterior work requires separate review</i> <i>approval thru historic preservation</i>
	CERTIFICATION		

I hereby certify that I am the owner of record of the named property, or that the proposed work is authorized by the owner of record and that I have been authorized by the owner to make this application as his authorized agent and I agree to conform to all applicable laws of this jurisdiction. In addition, if a permit for work described in the appication is issued, I certify that the code official's authorized representative shall have the authority to enter all areas covered by such permit at any reasonable hour to enforce the provision of the code(s) applicable to such permit.

SIGNATURE OF APPLICANT	ADDRESS	DATE	PHONE
RESPONSIBLE PERSON IN CHARGE OF WORK, TITLE		DATE	PHONE

4-11-13 GF / BKL

~~A-B~~ B GF / BKL
JM

~~FMG - PASS~~

~~* FIRE / SMOKE STOP MUST BE INSTALLED IN PENETRATIONS~~

FINAL - INSP

BLDG - PASS

ELEC - ~~PASS~~ F. - CUR PLATE @ GFCI

FD - FAIL - CONDITIONS OF EGRESS NOT MET
IN ADJACENT BLDG

PLUMBING - FAIL

TRAP NOT FROM IND WASTE
PROPER



6-10-13 GF / BKL
JM

FINAL FAIL

PLUMBING

ELEC - NEED GFCI

6-12-13 GF PASS C of O



Certificate of Occupancy

CITY OF PORTLAND, MAINE

Department of Planning and Urban Development
Building Inspections Division



Location: 49 EXCHANGE ST

CBL: 032 E004001

Issued To: Palacci Albert

Issued Date: 06/12/2013

This is to certify that the building, premises, or part thereof, at the above location, built-altered-changed as to use under Building Permit No. 201249305 has had a final inspection, has been found to conform substantially to the requirements of the Building Code and the Land Use Code of the City of Portland, and is hereby approved for occupancy or use, limited or otherwise, as indicated below.

PORTION OF BUILDING OR PREMISES

Front of Basement from 64 Market St.

APPROVED OCCUPANCY

USE GROUP: M - CAFÉ & BOOK STORE

TYPE: 3B

IBC 2009 (MUBEC)

LIMITING CONDITIONS: NONE

Approved:

Inspector
Inspection Division Director

Notice: This certificate identifies the legal use of the building or premises, and ought to be transferred from owner to owner upon the sale of the property.

DISPLAY THIS CARD ON PRINCIPAL FRONTAGE OF WORK



CITY OF PORTLAND BUILDING PERMIT



This is to certify that

PALACCI ALBERT

Located at

49 EXCHANGE ST

PERMIT ID: 2012-49305

CBL: 032 E004001

has permission to **Change of Use from - Storage to Retail**

provided that the person or persons, firm or corporation accepting this permit shall comply with all of the provisions of the Statutes of Maine and of the Ordinances of the City of Portland regulating the construction, maintenance and use of the buildings and structures, and of the application on file in the department.

Notification of inspection and written permission procured before this building or part thereof is lathed or otherwise closed-in. 48 HOUR NOTICE IS REQUIRED.

A final inspection must be completed by owner before this building or part thereof is occupied. If a certificate of occupancy is required, it must be procured prior to occupancy.

Fire Prevention Officer

Joanne Bonke

Code Enforcement Officer / Plan Reviewer

**THIS CARD MUST BE POSTED ON THE STREET SIDE OF THE PROPERTY
THERE IS A PENALTY FOR REMOVING THIS CARD**

SCANNED

City of Portland, Maine - Building or Use Permit

389 Congress Street, 04101 Tel: (207) 874-8703, Fax: (207) 874-8716

Permit No: 2012-49305	Date Applied For: 10/16/2012	CBL: 032 E004001
---------------------------------	--	----------------------------

Location of Construction: 49 EXCHANGE ST	Owner Name: PALACCI ALBERT	Owner Address: 4761 BROADWAY	Phone:
Business Name:	Contractor Name:	Contractor Address:	Phone:
Lessee/Buyer's Name	Phone:	Permit Type: Change of Use	

Proposed Use: Change of Use from - Storage to Restuarant/Book St	Proposed Project Description: Change of Use from - Storage to Retail
--	--

Dept: Historic	Status: Approved w/Conditions	Reviewer: Robert Wiener	Approval Date: 02/11/2013
Note: Approved Historic Preservation application 2/4/13, as site plan under planning.			Ok to Issue: <input checked="" type="checkbox"/>
<ol style="list-style-type: none"> 1) 2.Historic Preservation Certificate of Appropriateness does not constitute a building permit - any work requiring a building permit must be approved by the Inspections Department. 2) 3.Exterior wood moldings are to be preserved, or if damaged beyond repair pieces may be replaced with exactly matching wood replacements. 3) 4.If masonry repair is necessary, all brick and mortar used must be compatible with the historic masonry, in the size and profile of brick and joints, color, texture, and hardness of both brick and mortar. Contact Historic Preservation staff for guidance. 4) 1.Historic Preservation staff is to be notified after the threshold has been lowered and the doors have been lengthened, and at the completion of these renovations. 			

Dept: Zoning	Status: Approved w/Conditions	Reviewer: Ann Machado	Approval Date: 10/16/2012
Note: Created in One Solution.			Ok to Issue: <input checked="" type="checkbox"/>
<ol style="list-style-type: none"> 1) Separate permits shall be required for any new signage. 2) With the issuance of this permit and the certificate of occupancy the use of this space shall remain restaurant (more than nine seats) & a bookstore. Any change of use shall require a separate permit application for review and approval. 3) ANY exterior work requires a separate review and approval thru Historic Preservation. This property is located within an Historic District. 4) This permit is being approved on the basis of plans submitted. Any deviations shall require a separate approval before starting that work. 			

Dept: Building	Status: Approved w/Conditions	Reviewer: Jeanie Bourke	Approval Date: 01/29/2013
Note: Created in One Solution.			Ok to Issue: <input checked="" type="checkbox"/>
<ol style="list-style-type: none"> 1) Application approval based upon information provided by the applicant or design professional, including revisions dated received 1/28/13. Any deviation from approved plans requires separate review and approval prior to work. 2) Draftstopping and Fireblocking in combustibile concealed spaces and locations shall be in accordance with IBC Sec. 717, including concealed wall spaces (max. 10' horizontally) 3) This permit is approved with the condition that the framing details to increase the ceiling height at the stair and landing be submitted to this office for review prior to prior to commencing this work. 4) Equipment shall be installed in compliance with the manufacturer's specifications and the UL listing. 5) Separate permits are required for any electrical, plumbing, sprinkler, fire alarm, HVAC systems, heating appliances, including pellet/wood stoves, commercial hood exhaust systems and fuel tanks. Separate plans may need to be submitted for approval as a part of this process. 6) This permit approves the installation of one bathroom per State Statute allowance with an occupancy maximum of 40. 7) Approval of City license is subject to health inspections per the Food Code. 			

Location of Construction: 49 EXCHANGE ST	Owner Name: PALACCI ALBERT	Owner Address: 4761 BROADWAY	Phone:
Business Name:	Contractor Name:	Contractor Address:	Phone:
Lessee/Buyer's Name	Phone:	Permit Type: Change of Use	

- 8) Ventilation of this space is required per ASHRAE 62.2 or 62.1, 2007 edition.
- 9) New café, restaurant, lounge, bar or retail establishment where food or drink is sold and/or prepared shall meet the requirements of the City and State Food Codes.

Dept: Fire **Status:** Approved w/Conditions **Reviewer:** Ben Wallace Jr **Approval Date:** 02/11/2013
Note: **Ok to Issue:**

- 1) ****This building and space requires a supervised fire alarm system.****
A separate Fire Alarm Permit is required for new systems; or for work effecting more than 5 fire alarm devices; or replacement of a fire alarm panel with a different model. This review does not include approval of fire alarm system design or installation.
- 2) ****A certificate of occupancy shall not be issued for this space until work under permit 2013-00400 is completed and final inspection for both permits pass. The owner and tenant understands and have agreed. A copy of the e-mail is saved on the G drive.****
- 3) Notice: The first scheduled final inspection fee is at no charge. Additional inspections shall be billed at \$75 for each inspector.
- 4) Any cutting and welding done will require a Hot Work Permit from Fire Department.
- 5) Emergency lights and exit signs are required. Emergency lights and exit signs are required to be labeled in relation to the panel and circuit and on the same circuit as the lighting for the area they serve.
- 6) Fire extinguishers are required per NFPA 1.
- 7) ****The fire alarm system design shall be evaluated for the renovated areas by an NICET IV certified interior fire alarm designer or a licensed engineer for compliance with the code. A compliance letter is required prior to the final inspection.****
****A current inspection sticker from an approved fire alarm inspection company is required prior to the final inspection.****
- 8) Construction or installation shall comply with City Code Chapter 10.
- 9) Fire walls, fire barriers, fire partitions, smoke barriers and smoke partitions or any other wall required to have protected openings or penetrations shall be effectively and permanently identified with signs or stenciling in accessible concealed floor, floor-ceiling or attic spaces at intervals not exceeding 30 feet with lettering not less than 0.5 inches in height.
- 10) Street addresses shall be marked on the structure and shall be as approved by the City E-911 Addressing Officer. Contact Michelle Sweeney at 874-8682 for further information.
- 11) Through-penetrations and membrane penetrations in fire walls, fire barrier walls, and fire resistance rated horizontal assemblies shall be protected by firestop systems or devices in conformance with NFPA 101:8.3.5 (ASTM E 814 or ANSI/UL 1479). Providing firestop labels at each firestop system or device and an onsite manual containing the detail for each firestop system or device used for the project will streamline final inspection approvals.

BUILDING PERMIT INSPECTION PROCEDURES
Please call 874-8703 (ONLY)
or email: buildinginspections@portlandmaine.gov

With the issuance of this permit, the owner, builder or their designee is required to provide adequate notice to the city of Portland Inspections Services for the following inspections. Appointments must be requested 48 to 72 hours in advance of the required inspection. The inspection date will need to be confirmed by this office.

- **Please read the conditions of approval that is attached to this permit!! Contact this office if you have any questions.**
- **Permits expire in 6 months. If the project is not started or ceases for 6 months.**
- **If the inspection requirements are not followed as stated below additional fees may be incurred due to the issuance of a "Stop Work Order" and subsequent release to continue.**

REQUIRED INSPECTIONS:

The project cannot move to the next phase prior to the required inspection and approval to continue, REGARDLESS OF THE NOTICE OF CIRCUMSTANCES.

IF THE PERMIT REQUIRES A CERTIFICATE OF OCCUPANCY, IT MUST BE PAID FOR AND ISSUED TO THE OWNER OR DESIGNEE BEFORE THE SPACE MAY BE OCCUPIED.

2012-10-5193

General Building Permit Application



If you or the property owner owes real estate or personal property taxes or user charges on any property within the City, payment arrangements must be made before permits of any kind are accepted.

Location/Address of Construction: <u>49 Exchange by Market -</u>		
Total Square Footage of Proposed Structure/Area <u>459 sq ft</u>		Square Footage of Lot
Tax Assessor's Chart, Block & Lot Chart# <u>32</u> Block# <u>E</u> Lot# <u>4</u>	Applicant * must be owner, Lessee or Buyer * Name <u>MR PALACCI</u> Address <u>104 EXCHANGE ST.</u> City, State & Zip <u>PORTLAND ME 04101</u>	Telephone: <u>207-772-8107</u>
Lessee/DBA (If Applicable) <u>Darren Thomas</u> <u>22 Caleb St -</u> <u>Port. ME. 04102</u> <u>(207) 671-5524</u>	Owner (if different from Applicant) Name Address City, State & Zip	Cost Of Work: \$ <u>4,500.00</u> C of O Fee: \$ <u>75</u> Total Fee: \$ <u>70</u>
Current legal use (i.e. single family) <u>STORAGE</u> If vacant, what was the previous use? Proposed Specific use: <u>Mercantile Restaurant</u> Is property part of a subdivision? <input type="checkbox"/> If yes, please name <u>RECEIVED</u> Project description: <u>CofU -> Storage - Retail</u>		
Contractor's name: <u>Benjamin Downs</u> Address: <u>68 Fellows street</u> City, State & Zip <u>South Portland ME 04106</u> Telephone: <u>207-749-8235</u> Who should we contact when the permit is ready: <u>207-671-5524 Darren</u> Telephone: Mailing address:		

Dept of Building Inspections
City of Portland Maine

OCT 16 2012

Please submit all of the information outlined on the applicable Checklist. Failure to do so will result in the automatic denial of your permit.

In order to be sure the City fully understands the full scope of the project, the Planning and Development Department may request additional information prior to the issuance of a permit. For further information or to download copies of this form and other applications visit the Inspections Division on-line at www.portlandmaine.gov, or stop by the Inspections Division office, room 315 City Hall or call 874-8703.

I hereby certify that I am the Owner of record of the named property, or that the owner of record authorizes the proposed work and that I have been authorized by the owner to make this application as his/her authorized agent. I agree to conform to all applicable laws of this jurisdiction. In addition, if a permit for work described in this application is issued, I certify that the Code Official's authorized representative shall have the authority to enter all areas covered by this permit at any reasonable hour to enforce the provisions of the codes applicable to this permit.

Signature: Joyce Palacci Date: 10-16-2012

This is not a permit; you may not commence ANY work until the permit is issue

See Revisions
This highlights
The wrong space

exchange

Existing

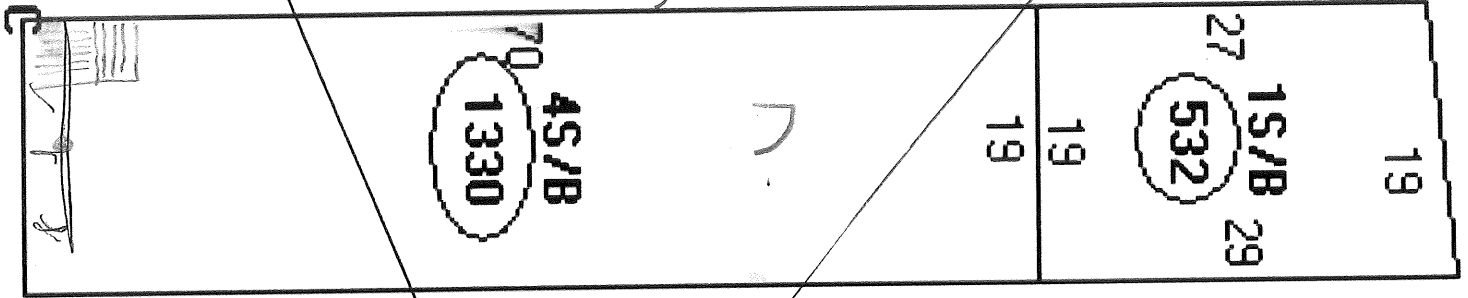

market

2x4 framing 16" oc w Greenboard

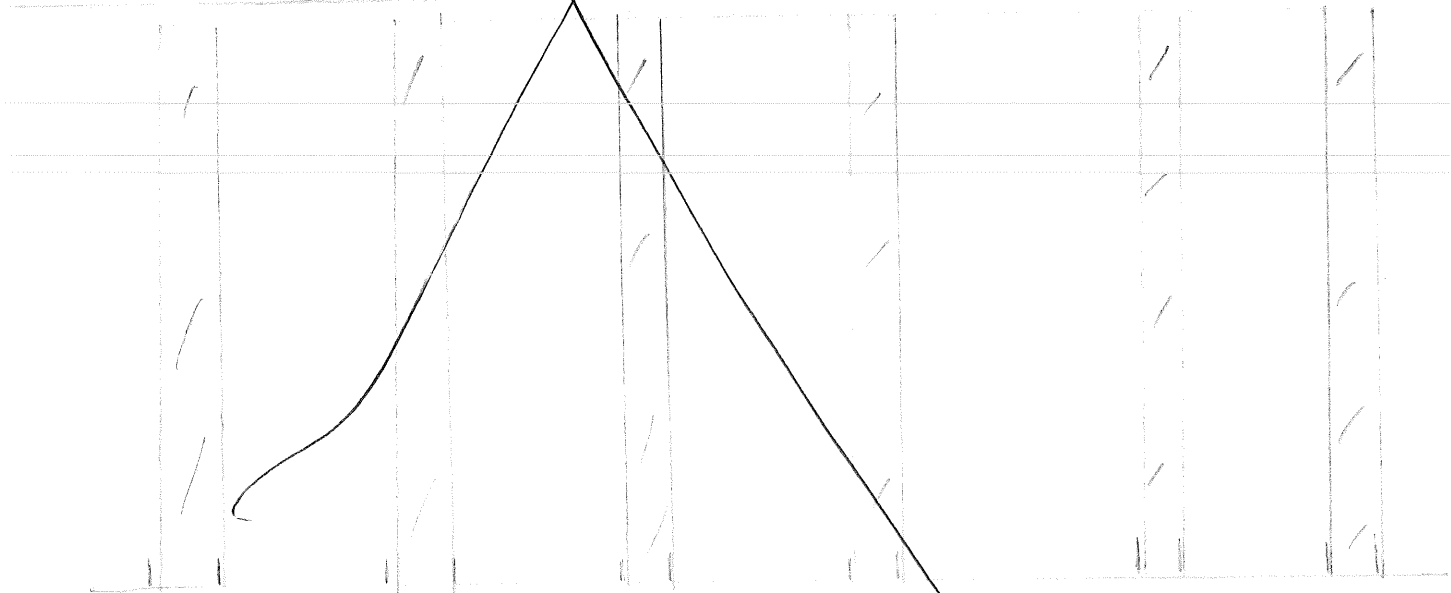

175 seats?

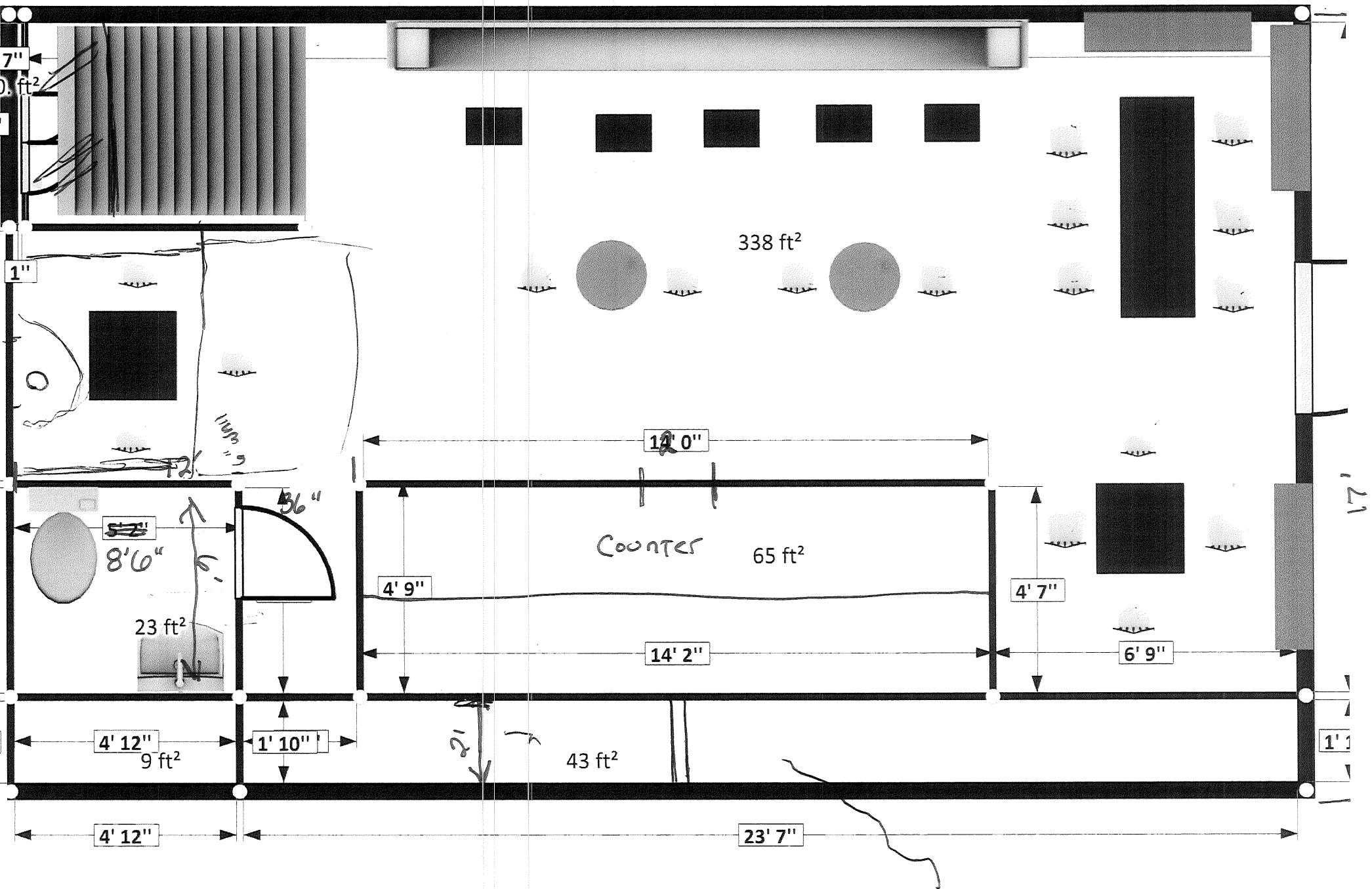

My Map

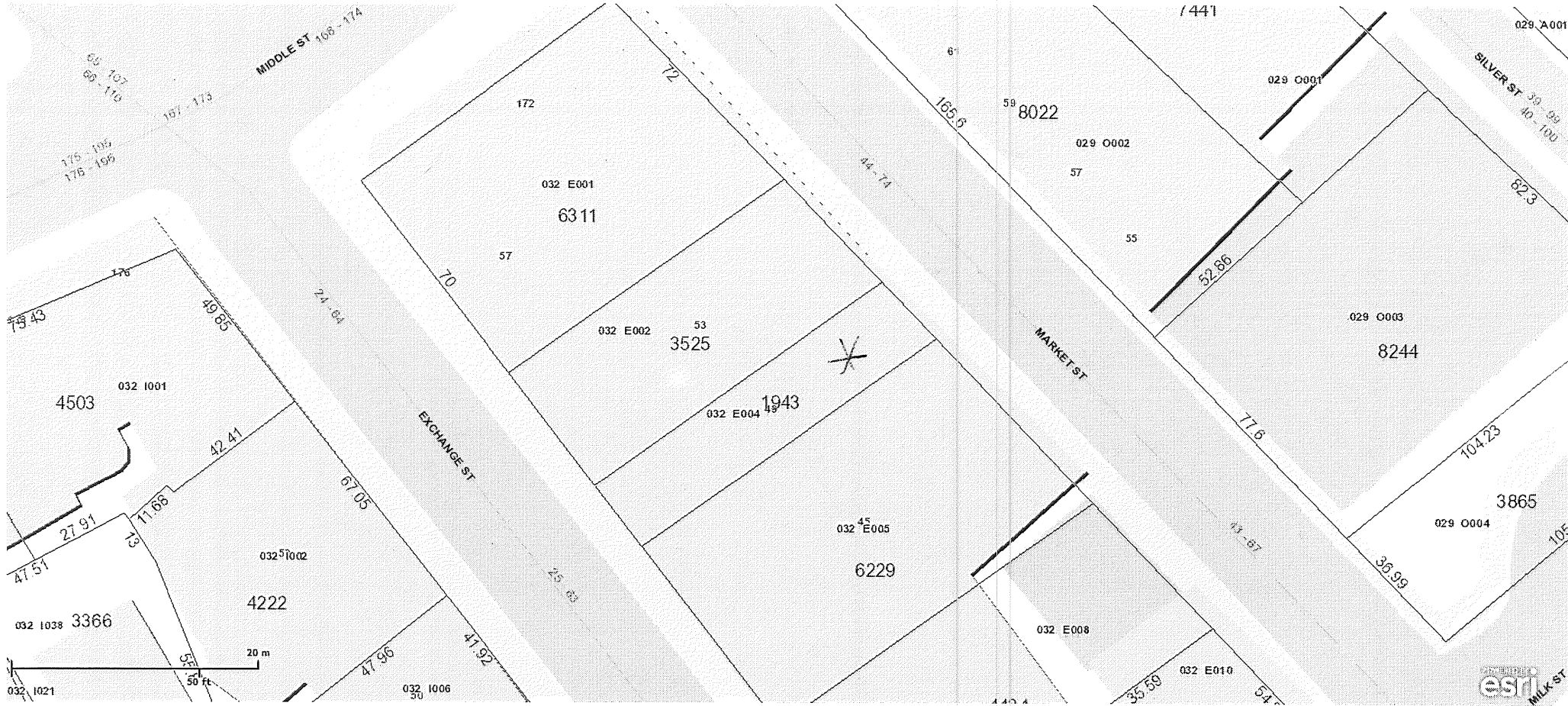



Authorization to use space

I, MR PALACCI (property owner) do hereby authorize and agree to permit MR THOMAS (Applicant) to enter my property at 64 MARKET, in order to create a mercantile space and conduct business at such time that all licensing, inspections and code requirements have been successfully met.

This job requires more memory than is available in this printer.

Try one or more of the following, and then print again:

For the output format, choose Optimize For Portability.

In the Device Settings page, make sure the Available PostScript Memory is accurate.

Reduce the number of fonts in the document.

Print the document in parts.

J Palaciz 10-15-2012



MALONE

Commercial and Investment Real Estate

Malone Commercial Brokers, Inc.
5 Moulton Street
Portland, Maine 04101

Tel (207) 772-2422
Fax (207) 774-5114
www.malonecb.com

December 10, 2012

Joe Palacci
104 Exchange Street
Portland, ME 04101

Dear Mr. Palacci,

In regards to the Edgecomb space; I measured the space with Malone Commercial Brokers laser measuring device. The interior dimension of the space, including the office, measured to nearly 2,600 SF. If you would like to discuss this in greater detail I can be reached at 207.772.0088.

Thank you,

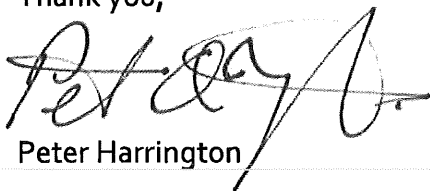

Peter Harrington

RESTORE
Doors

RECEIVED
JAN 08 2013
Dept. of Building Inspections
City of Portland Maine

Edmund Pettus Place
Lynchburg, Virginia

2006/01/20



Jeanie Bourke - Thomas Cafe 66 Market Street

From: Michael Chesnut <michael@calebjohnsonarchitects.com>
To: Jeanie Bourke <jmb@portlandmaine.gov>
Date: 1/29/2013 8:43 AM
Subject: Thomas Cafe 66 Market Street
CC: Cat Sumislaski <mailto:>
Attachments: PERMIT SET 1.25.13.pdf

Hello Jeanie,

Attached is the Permit set. We want to wait for construction to begin before we open up the ceiling and determine what needs to be done to achieve the head clearance at the landing. Can you add a condition to the permit that we need to provide the city with a construction sketch (stamped by a structural engineer) which shows how we will address this issue, so we can move forward.

Thank you,

Michael Chestnutt
Project Architect
Caleb Johnson Architects + Builders
265 Main Street, Suite 201
Biddeford, Maine 04005
Office: 207.283.8777
Fax: 207.283.0087
Cell: 207.756.4153
michael@calebjohnsonarchitects.com
<http://calebjohnsonarchitects.com>

RECEIVED

JAN 08 2013

Dept. of Building Inspection
City of Portland, Maine

To Be Restored





Edgar Allan Poe Gallery
Lafayette Street, New York

2006/01/20

The Underground Café
Business Plan Submitted 6 December 2012
Darren Thomas

Summary

The Underground Café is a new, independent coffee shop and bookstore that will offer the Portland community a fresh alternative to the current local coffee shop experience. Patrons will be able to purchase new and used books and ready-to-go comfort foods and beverages made by local food producers. In an effort to align with today's fast-paced lifestyle, the Underground Café will focus on a few delicious food and drink options offered in a convenient, ready-to-go format. Patrons who want to linger, will find a comfortable place to enjoy something to eat, read a book, or browse the web using the complimentary Wi-Fi connection.

The Underground Café will provide a "get comfortable" environment with special attention paid to optimizing fast service. The Underground Café will also be designed to accommodate a variety of community-based events, from hosting business meetings, author readings, spoken-word events, and art gatherings.

Eye on the Future

Once established, the Underground Café intends to create a local Old Port delivery service for its product line. The Underground Café will cater gatherings and business meetings. This will provide an added convenience for our customer base during time constraints or inclement weather.

Marketplace Needs

Most folks employed in the Old Port have little more than a half-hour for lunch. This makes a wait time of 5-10 minutes for a latté a big inconvenience, especially when it's for someone else. All items for sale at the Underground Café will be chosen based on quality and minimal service time to customer.

Observations

Coffee houses have a tendency to over extend their menus by trying to have something for everyone. They offer every drink under the sun along with many food items requiring extensive preparation and cram everyone into the same wait line. This means the gentleman waiting for a regular coffee waits unnecessarily for a frappuccino to be made for someone else.

The Underground Café will have a limited menu that will be rotated on a monthly basis. All items on the menu will share a common service-to-customer time frame.

Customer Profile & Market Share

Being located in the heart of Portland's Old Port area, The Underground Café's potential customer will include local citizens, employees of local businesses, students, and tourists. The expected age for Underground Café patrons is expected to range from 16 to 70 years of age.

Youth patrons the Underground Café expects to cater to:

- Portland High School: Great study environment with free Wi-Fi, books, and magazines available
- Maine college of Art: Student art openings
- University of Maine: Meetings and study groups

Adult patrons the Underground Café expects to cater to:

- Local citizens
- Local business clientele
- Tourists

Industry Analysis and Outlook

According to First Research (SIC Code: 5812, NAICS Code: 72221), in 2011, there were about 20,000 coffee shop businesses in the U.S. with combined revenues of \$10 billion.

According to the latest National Coffee Drinking Study from the National Coffee Association, 40% of 18-24 year olds are drinking coffee each day — this is a sharp rise from the 31% of this age group who said they enjoyed a daily dose of java during 2010. This increase brought the consumption of coffee among this age group back to its 2009 level. In the same National Coffee Drinking Study, 54% of adults age 25-39 reported drinking coffee each day, another significant increase from the 44% who reported drinking coffee daily during 2010. (<http://www.sbdnet.org/small-business-research-reports/coffee-shop-2012>)

Most adult coffee drinkers said their lifelong habit began during their teenage years. In fact, 54% said they began drinking coffee between 13 and 19. Another 22% reported their coffee cravings started between the ages of 20 and 24. This means that 76% of adult coffee drinkers began drinking coffee by the time they were 24. So, despite the large amount of marketing and advertising directed at the younger age groups, savvy coffee shop owners will not forget to cater some of their offerings to the adult and senior market. **Target Market- According to NCA's National Coffee Drinking Trends (NCDT) study** (<http://www.ncausa.org/i4a/pages/index.cfm?pageid=731>)

Not surprisingly, coffee shop owners can find regular (weekly or more) customers in the younger age groups, particularly those in high schools, college and the newly employed (first job).

Competition

Starbucks, Bard, Mornings in Paris, Crema, Dunkin Donuts, and others currently share the coffee business in the Old Port.

- According to the National Coffee Guide (<http://www.national-coffee-guide.com/Coffee%20Guide/Maine%20Coffee.htm>), there are 16 coffee shops in the Portland area, of which 6 reside in the immediate Old Port area of Portland.
- Long wait times are commonly found in the Old Port area coffee shops and may in fact be caused by over extended product lines. Service issues arise when service for one product takes considerably longer than other menu items. This results in every customer being relegated to wait times regardless of their order (pouring a coffee takes less time than creating a frappuccino). The

Underground Café hopes to pull 5 to 8% from other establishments mainly due to a focus on quick turnaround times. We expect the average wait time not to exceed 5 minutes. It is our belief, given the options of quick turn around or food preference, that the Old Port customer will opt for the quick turnaround most times, as the average lunch time is approximately one half-hour.

- Combining books, comfort foods, and quick service, the Underground Café hopes to distinguish itself from the competition by filling the needs of those in hurry as well as those folks looking for a unique place to relax. The Underground Café intends to fill the void left by the exit of Casco Bay Books by providing the Old Port community with books for sale, temporary lending, and trade. We hope to fill this void before someone else, as this will immediately and definitively set the Underground Café apart from its competition.

Pricing & Production Costs

Because the Underground Café will be selling ready-to-go prepackaged food items, food preparation costs and labor will be minimal. The Underground Café will have no employees, apart from the owner, further minimizing overhead expense. Low overhead expenses will allow the Underground Café to offer its convenient foods at a good value to the customer.

The Underground Café intends to purchase some items in bulk and shy away from the mark up commonly found in the Old Port area (double the wholesale price + shipping and handling). Direct materials, labor, overhead, and local pricing will be variables considered for pricing structure. After these costs are determined, a price will then be selected that will be both profitable and competitive. Price bundling and complementary pricing will be used to entice sales. There is an expectation that food cost will be generally 30-35% of the price, allowing wiggle room for pricing. The basic formula that will be used in pricing is as follows: (prices will ultimately match or beat local average costs).

Divide food cost by 35%: *Wholesale cost / .35 = retail cost*
e.g., If a sandwich costs \$2 to make, the calculation is as follows:
 $2 / .35 = \$5.71$ (rounded up, which would make it \$5.99)

Organization & Management

The Underground Café will be owned and operated by Darren Thomas who brings his love for coffee and business experience to the establishment. Mr. Thomas has worked for several coffee shops including Portland's first cyber café, The Cosmic Hippo. During his employment at the Cosmic Hippo, Mr. Thomas was responsible for increasing business up to 60% as a result of his creative marketing campaigns. Additionally, Mr. Thomas successfully built and operated one of Portland first hot dog stands (D&D Dogs, circa 1985). Having lived and worked in Portland for over 40 years, Mr. Thomas has a thorough understanding of the needs and expectations of Portland's citizens making him uniquely qualified to establish and operate the Underground Café.

Product Line (please see attached menu for current products)

The Underground Café will sell a ready-to-go selection of unique comfort foods, snacks, coffee drinks, teas, and other beverages. The Underground Café intends to take full advantage of its location by offering its space for small business meetings and community gatherings. Due to its strategic placement and availability to those who live and work in the Old Port area, the space itself will be considered one of its marketable products.

MARKET STREET

RELOCATED PULL STATION

1
A-3.1

SIDEWALK

NEW WALL SET ON MASONRY HALF WALL

SLOPED PROTRUSION ON GROUND

ADJACENT BUILDING

DN

BOOKS

60 MIN FIRE-RATED DOOR
SIGN: "NOT AN EXIT."
"MECH ROOM.
NO PUBLIC ACCESS."

MECH

1 HR

BOOKS

PLUMBING TO BE REDONE FOR HEADROOM

TABLE TYPICAL OF 8

BOOKS

BOOKS

REMOVE 1'-0" LEDGE FOR ADA COMPLIANCE

ADJACENT BUILDING

1
GROUND FLOOR
SCALE: 1/4" = 1'-0"

NOTES:

1. CEILING TO BE SMOKE TIGHT.
2. DEMOLISH ALL EXISTING EXPOSED SPRINKLER PIPES AND HEADS.

CALEB JOHNSON ARCHITECTS
265 MAIN ST. UNIT 201, BIDDEFORD, MAINE 04005
T: 207.283.8777 F: 207.283.0087
WWW.CALEBJOHNSONARCHITECTS.COM

DRAFTERPERSON: CAT SUMIASKI
DATE OF ISSUE: 1/3/13
PROJECT STATUS: LIFE SAFETY REVIEW

A-1.1 FLOOR PLAN
THOMAS CAFE
DARREN THOMAS
66 MARKET ST. PORTLAND, ME 04101

Another less tangible product that the Underground Café will offer is short turnaround time. Service turnaround time is improved by a limited-rotating menu of food stuffs (same number of products with certain items to rotate out for others-providing ongoing alternative food stuffs). This will improve customer service satisfaction and incentive to come back.

Marketing

Marketing will include, but not be limited to in-house promotions, website, social media, public relations, print collateral, partnering with complementary businesses, and community networking.

Funding

Funding will be supplied solely by owner, Darren Thomas.

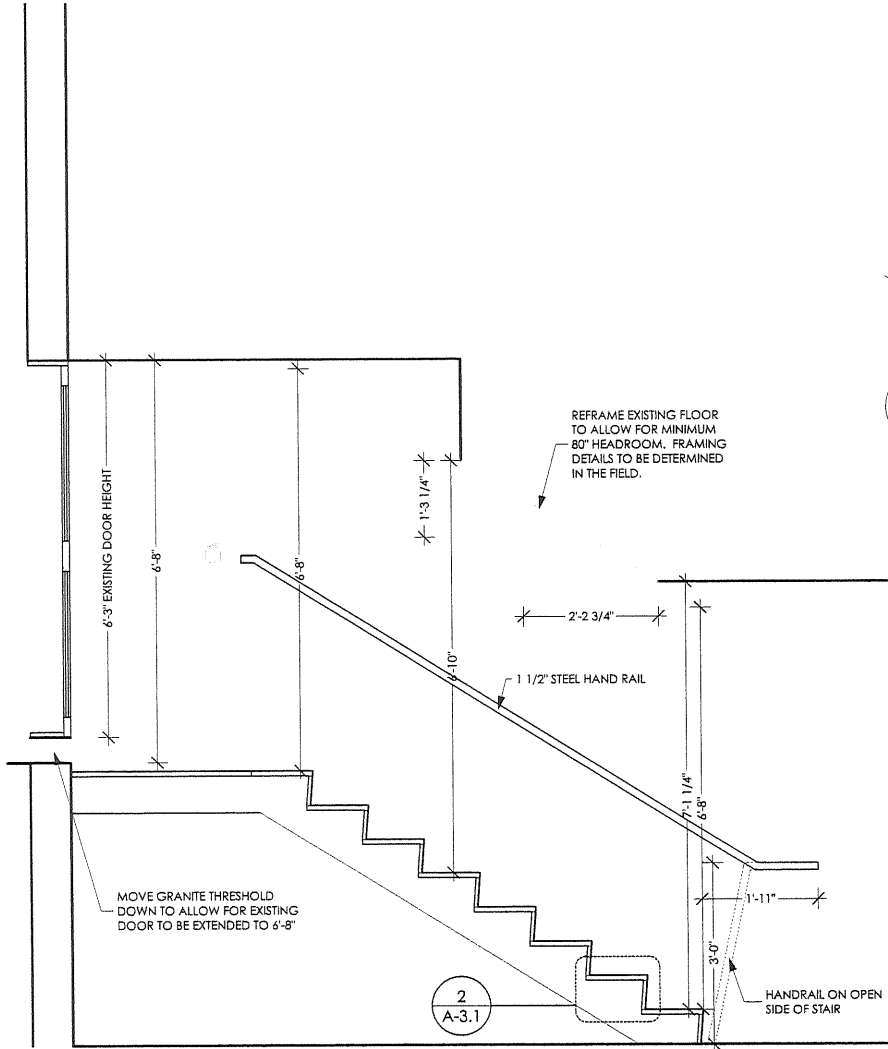

1 STAIR SECTION
SCALE: 1/2" = 1'-0"

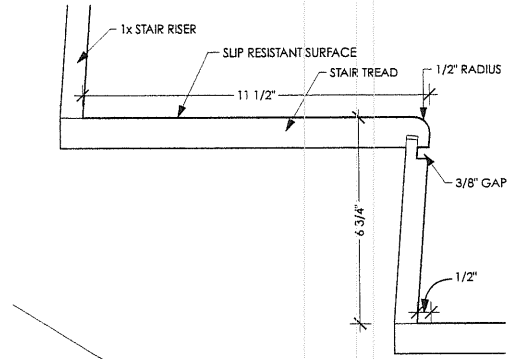

2 STAIR DETAIL
SCALE: 3" = 1'-0"

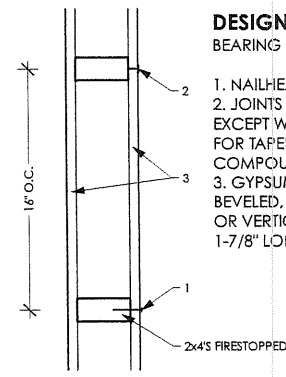

3 1 HR RATED WALL
SCALE: 1 1/2" = 1'-0"

DESIGN # U305
BEARING WALL RATING - 1 HR

1. NAILHEADS - EXPOSED OR COVERED W/ JOINT COMPOUND.
2. JOINTS - EXPOSED OR COVERED W/ FIBER TAPE AND JOINT COMPOUND, EXCEPT WHERE REQUIRED FOR SPECIFIC EDGE CONFIGURATION. FOR TAPERED, ROUNDED-EDGE WALLBOARD, JOINTS COVERED WITH JOINT COMPOUND OR FIBER TAPE AND JOINT COMPOUND. JOINTS REINFORCED.
3. GYPSUM BOARD - 5/8" THICK WALLBOARD PAPER OR VINYL SURFACED, WITH BEVELED, SQUARE, OR TAPERED EDGES, APPLIED EITHER HORIZONTALLY OR VERTICALLY. WALLBOARD NAILED 7" O.C. W/ 6d CEMENT COATED NAILS 1-7/8" LONG, 0.0915" SHANK dia AND 1/4" DIAM HEADS.

MARKET STREET

SIDEWALK

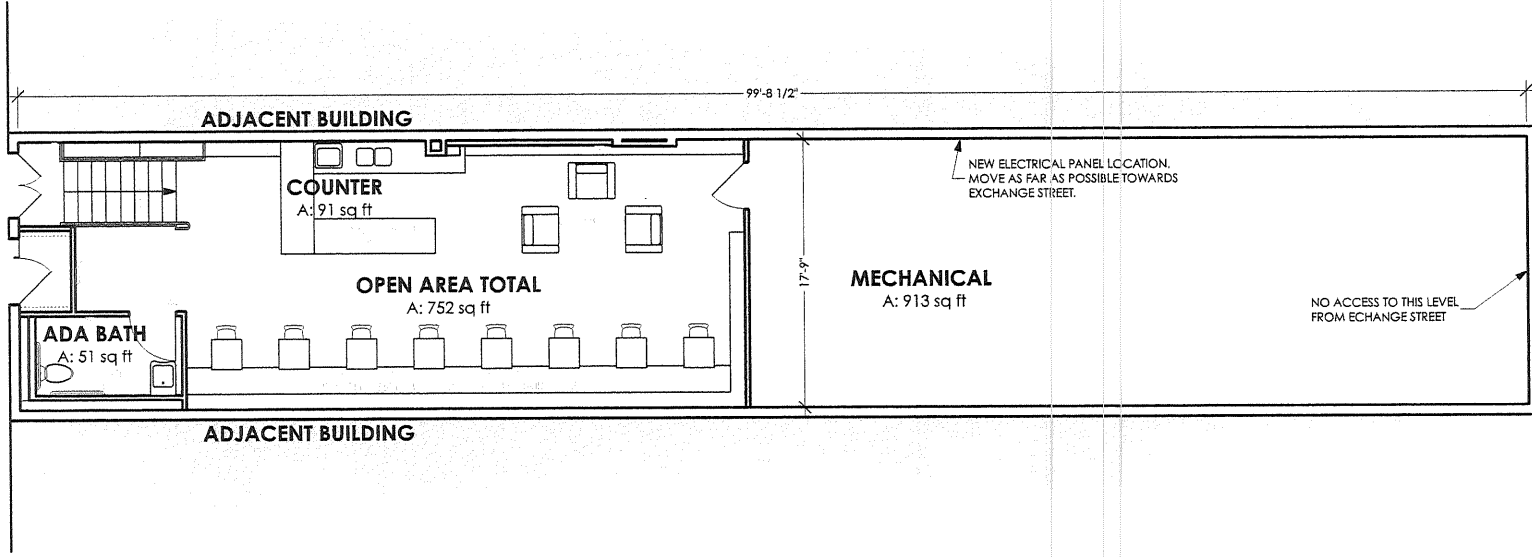

1

SITE PLAN

SCALE: 1/8" = 1'-0"

CALEB JOHNSON ARCHITECTS
 265 MAIN ST. UNIT 201, BIDDEFORD, MAINE 04005
 T: 207.283.8777 F: 207.283.0087
 WWW.CALEBJOHNSONARCHITECTS.COM

DRAFTSPERSON:
 CAT SUMMLASHI
 DATE OF ISSUE:
 1/3/13
 PROJECT STATUS:
 LIFE SAFETY REVIEW

A-1.0 SITE PLAN
THOMAS CAFE
 DARREN THOMAS
 66 MARKET ST, PORTLAND, ME 04101

NOT A CONTRACT DOCUMENT
 THIS SHEET IS THE PROPERTY OF THE ARCHITECT AND IS TO BE USED ONLY FOR THE PROJECT AND SITE SPECIFICALLY IDENTIFIED THEREON.
 1. THE ARCHITECT'S RESPONSIBILITY IS TO PROVIDE A DESIGN THAT COMPLIES WITH ALL APPLICABLE REGULATIONS AND STANDARDS.
 2. THE ARCHITECT IS NOT RESPONSIBLE FOR THE ACCURACY OF ANY INFORMATION PROVIDED BY OTHER PROFESSIONALS OR SOURCES.
 3. THE ARCHITECT'S DESIGN IS BASED ON THE INFORMATION PROVIDED BY THE CLIENT AND OTHER PROFESSIONALS.
 4. THE ARCHITECT IS NOT RESPONSIBLE FOR THE ACCURACY OF ANY INFORMATION PROVIDED BY OTHER PROFESSIONALS OR SOURCES.
 5. THE ARCHITECT'S DESIGN IS BASED ON THE INFORMATION PROVIDED BY THE CLIENT AND OTHER PROFESSIONALS.
 6. THE ARCHITECT IS NOT RESPONSIBLE FOR THE ACCURACY OF ANY INFORMATION PROVIDED BY OTHER PROFESSIONALS OR SOURCES.
 7. THE ARCHITECT'S DESIGN IS BASED ON THE INFORMATION PROVIDED BY THE CLIENT AND OTHER PROFESSIONALS.
 8. THE ARCHITECT IS NOT RESPONSIBLE FOR THE ACCURACY OF ANY INFORMATION PROVIDED BY OTHER PROFESSIONALS OR SOURCES.

Hi Darren,

Good to see you yesterday and see the project. I'm attaching several photos.

I know that there are still the code issues to work out, but as far as HP (historic Preservation) is concerned, we'll want some details on exactly how much the doors will be growing, how that will change the proportions, and how the kick plate will work to cover all the seams. For example, if the kick plate covers the full width that will hide the fact that the stiles (side pieces on the door, running vertically) don't run all the way to the bottom, as they will end and the addition to the rails (horizontal pieces) will go the full width, I imagine.

I think the work on the entrance is feasible - but we'll also want to see what the bottom will look like once the granite threshold is lowered. You and I talked a little about the treatment of the brickmold, and there might be a need to repair some brick work at the bottom. In addition to photos, I'm attaching the list of masons we have. There are others, I'm sure, but these are some we know who know how to work on old buildings.

Feel free to call or email with questions, ideas, or details.

Thanks,

Rob

>>> Darren Thomas <dhere38@yahoo.com> 1/4/2013 2:30 PM >>>
I think I may have neglected to attach the photos. Sorry :(

Darren Thomas
(207) 671-5524
dhere38@yahoo.com

----- Forwarded Message -----

From: Darren Thomas <dhere38@yahoo.com>
To: "rwiener@portlandmaine.gov" <rwiener@portlandmaine.gov>
Sent: Friday, January 4, 2013 12:33 PM
Subject: Market St. Space doorway

Good morning Robert. We spoke a couple of months ago regarding a space on Markets St. (I've included pictures to remind--converting to book store/coffee shop). You had indicated that to use that doorway your office would prefer we keep the exhisiting granite slab by counter sinking it (necessary to acchieve door height). I had the architect indicate that on the plans (should be on your desk :).

The plan is to restore the doors to their original state. I've included some pictures of the inside of the doors so you can see the original design. Also in order to extend the old doors to accomodate the increased door height we would like to retro fit the doors with brass kick plate (bottom of doors). The idea is to reuse and refurbish the doors to original or better state.

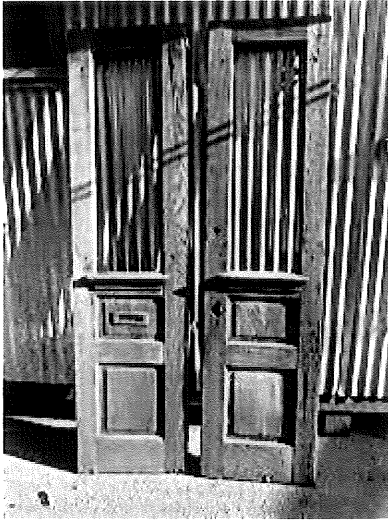

The doors above are similar to ours with out the kick plates. Please let me know if I can do anything to move us forward.

Thank you Robert, looking forward to hearing from you.

Darren Thomas
(207) 671-5524
dhere38@yahoo.com

Robert Wiener - Market St. Space doorway

From: Darren Thomas <dhere38@yahoo.com>
To: "rwiener@portlandmaine.gov" <rwiener@portlandmaine.gov>
Date: 1/4/2013 12:34 PM
Subject: Market St. Space doorway

Good morning Robert. We spoke a couple of months ago regarding a space on Markets St. (I've included pictures to remind--converting to book store/coffee shop). You had indicated that to use that doorway your office would prefer we keep the exhisiting granite slab by counter sinking it (necessary to achieve door height). I had the architect indicate that on the plans (should be on your desk :).

The plan is to restore the doors to their original state. I've included some pictures of the inside of the doors so you can see the original design. Also in order to extend the old doors to accomodate the increased door height we would like to retro fit the doors with brass kick plate (bottom of doors). The idea is to reuse and refurbish the doors to original or better state.



The doors above are similar to ours with out the kick plates. Please let me know if I can do anything to move us forward.

Thank you Robert, looking forward to hearing from you.

Darren Thomas
(207) 671-5524
dhere38@yahoo.com

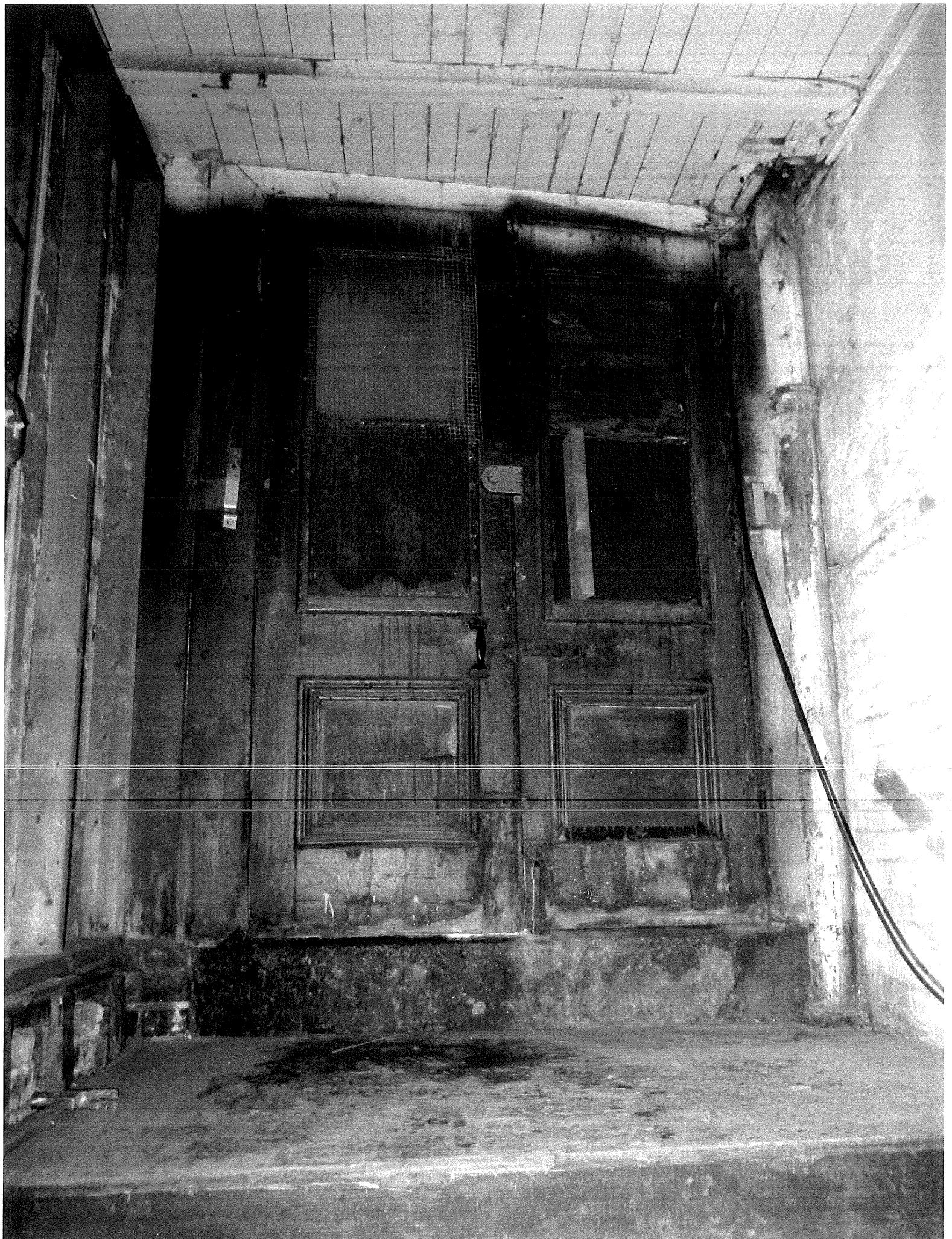

UNDERGROUND CAFE

MENU



KOSHER BAGELS & CREAM CHEESE

BAGELS

cinnamon raisin • everything • garlic
• onion • salt • spinach

CREAM CHEESE

herb • olive • plain

BAKERY

biscotti • breads • gluten-free cookies
croissants • gluten-free pies

SNACKS

granola bars • potato chips • deep fried peanuts
soft pretzels & mustard

BEVERAGES

americano • cappuccino • cider • espresso
hot chocolate • soda • tea



MARKET STREET • PORTLAND

7AM — 9PM • MON — SAT

207-671-5524

MARKET STREET

SIDEWALK

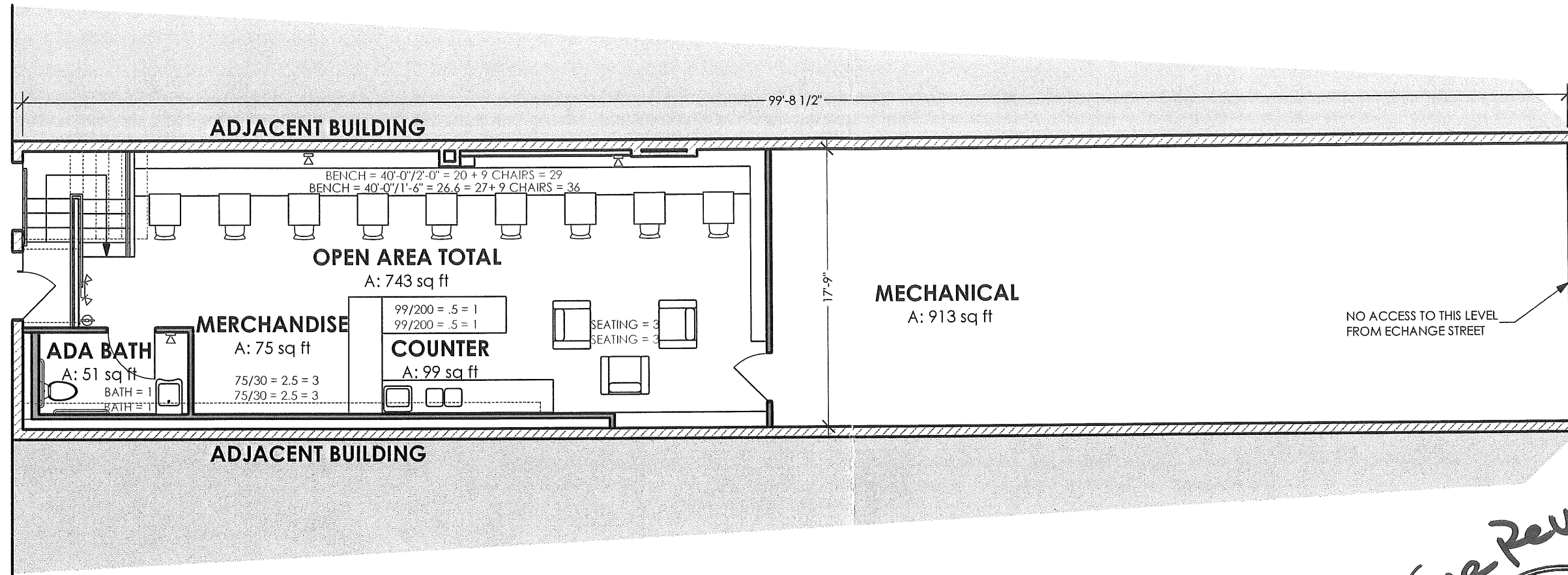

CALEB JOHNSON ARCHITECTS
 265 MAIN ST, UNIT 201, BIDDEFORD, MAINE 04005
 T: 207.283.8777 F: 207.283.0087
 WWW.CALEBJOHNSONARCHITECTS.COM

1 SITE PLAN
 SCALE: 1/8" = 1'-0"

See Revisions 1/4/13

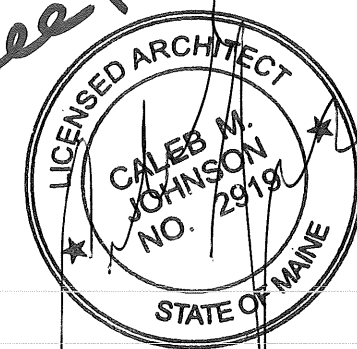

DRAFTSPERSON:
 CAT SUMISLASKI
 DATE OF ISSUE:
 12/13/12
 PROJECT STATUS:
 LIFE SAFETY REVIEW

IBC 2009 11.27.12
 USES: MERCANTILE M (BOOKSTORE) & ASSEMBLY A-2 (CAFE) WHERE ASSEMBLY TO MORE RESTRICTIVE
 OCCUPANCY (EXPLAINED ON FLOOR PLAN) = 36

1. SINGLE EGRESS PERMITTED WHEN OL 49 OR LESS IN A & M & EXISTING BUILDINGS ARE NOT REQUIRED TO HAVE ACCESSIBLE MEANS OF EGRESS.
2. AREA LESS THAN 5,000 SF, OL LESS THAN 100 AND AREA IS LEVEL OF DISCHARGE THEREFORE NO SPRINKLER SYSTEM REQUIRED
3. ONE HOUR RATED CEILING ASSEMBLY REQUIRED BETWEEN ASSEMBLY & MERC, NON FOR MERC TO MERC
4. STAIR HEADROOM NOT LESS THAN 80" AND HANDRAILS REQUIRED ON BOTH SIDES W/ SLIP RESISTANT & SECURED TREADS.
5. OL LESS THAN 50 THEREFORE MIN WIDTH OF STAIR PERMITTED TO BE 36" WITH 4 1/2" HANDRAIL PROTRUSION FROM WALL.
6. HEADROOM 7'-6" MINIMUM W/ PROJECTIONS NOT LESS THAN 6'-8" ABOVE FLOOR.

NFPA 101 2009 11.28.12
 USES: MERCANTILE CLASS C AS ASSEMBLY DEFINED AS GATHERING OF 50 OR MORE OCCUPANCY (EXPLAINED ON FLOOR PLAN) = 44

1. SINGLE EGRESS PERMITTED IN M CLASS C WHEN TRAVEL DISTANCE LESS THAN 75 FT.
2. SIZE OF SCOPE IS SMALLER THAN REQUIREMENTS THEREFORE NO SPRINKLER SYSTEM REQUIRED
3. NO RATED ASSEMBLY REQUIRED WHEN M ABOVE AND PROJECT IS M.
4. STAIR HEADROOM NOT LESS THAN 80" AND HANDRAILS REQUIRED ON BOTH SIDES W/ SLIP RESISTANT & SECURED TREADS.
5. OL LESS THAN 50 THEREFORE WITH OF STAIR PERMITTED TO BE 36" W/ 4 1/2" HANDRAIL PROTRUSION FROM WALL.
6. STAIR TREADS SHALL ALSO BE FREE OF PROTRUSIONS OR LIPS THAT COULD TRIP STAIR USER.
7. HEADROOM 7'-0" MINIMUM IN EXISTING BUILDINGS W/ PROJECTIONS NOT LESS THAN 6'-8" ABOVE FLOOR.
8. EXIT DOOR IN M CLASS C PERMITTED TO SWING INWARD AS IT IS LEVEL OF DISCHARGE.

RECEIVED
 DEC 19 2012
 Dept. of Building Inspections
 City of Portland Maine

A-1.0 SITE PLAN
THOMAS CAFE
 DARREN THOMAS
 66 MARKET ST, PORTLAND, ME 04101

MARKET STREET

FIX IN PLACE EXISTING DOOR. NO MODIFY. OWNER UNDERSTANDS ANY CHANGES REQUIRE CITY APPROVAL.

RELOCATED PULL STATION

SIDEWALK

NEW WALL SET ON MASONRY HALF WALL

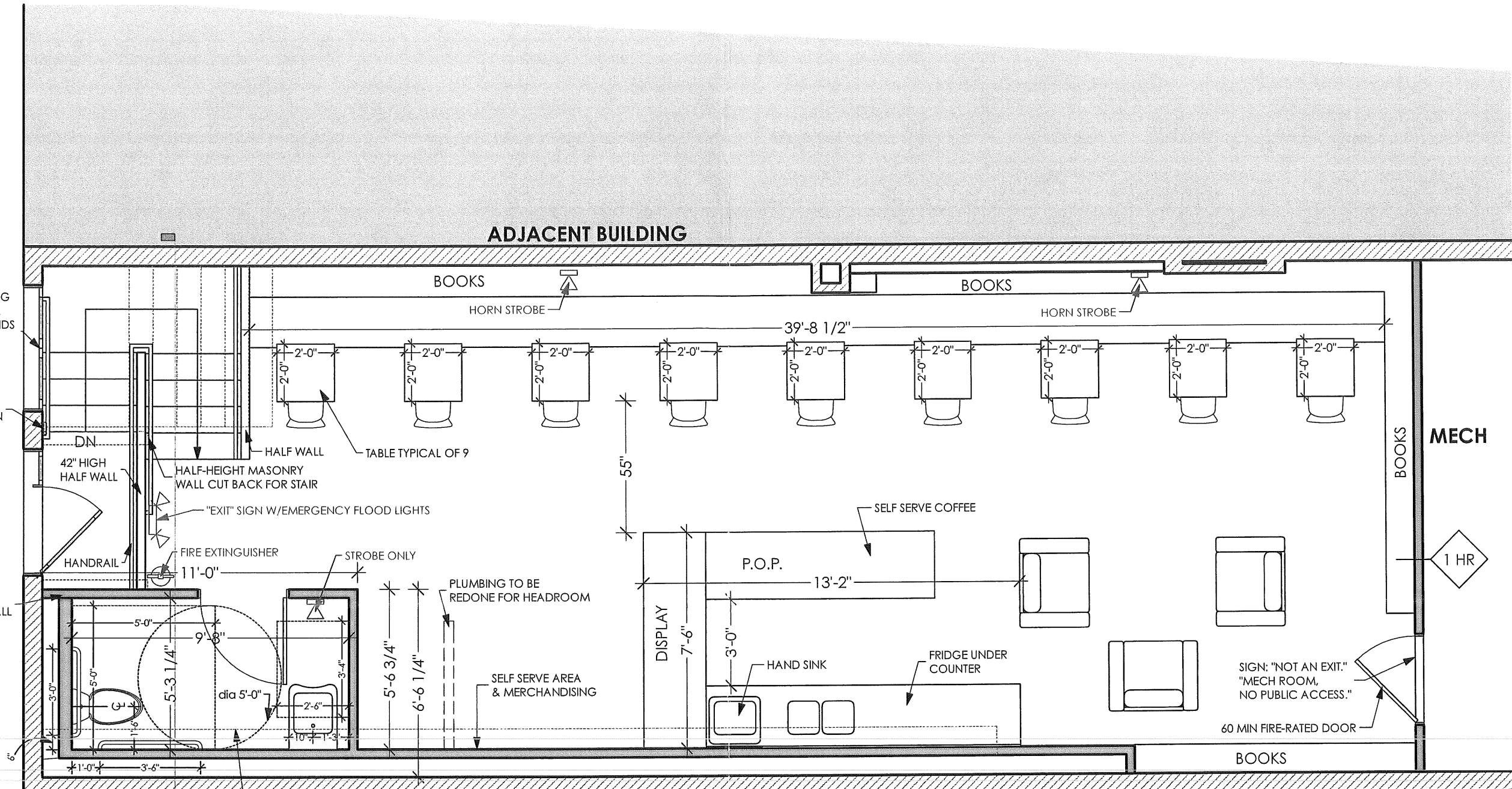

1

GROUND FLOOR

SCALE: 1/4" = 1'-0"

1
A-3.1

ADJACENT BUILDING

RECEIVED
DEC 19 2012
Dept. of Building Inspections
City of Portland Maine

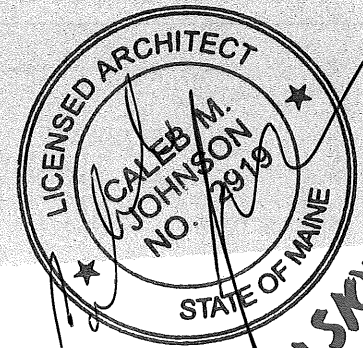

See Revisions 1/9/13

NOTES:

- 1. CEILING TO BE SMOKE TIGHT.
- 2. DEMOLISH ALL EXISTING EXPOSED SPRINKLER PIPES AND HEADS.

CALEB JOHNSON ARCHITECTS
 265 MAIN ST, UNIT 201, BIDDEFORD, MAINE 04005
 T: 207.283.8777 F: 207.283.0087
 WWW.CALEBJOHNSONARCHITECTS.COM

DRAFTSPERSON:
 CAT SUMISLASKI
 DATE OF ISSUE:
 12/13/12
 PROJECT STATUS:
 LIFE SAFETY REVIEW

A-1.1 FLOOR PLANS
THOMAS CAFE
 DARREN THOMAS
 66 MARKET ST, PORTLAND, ME 04101

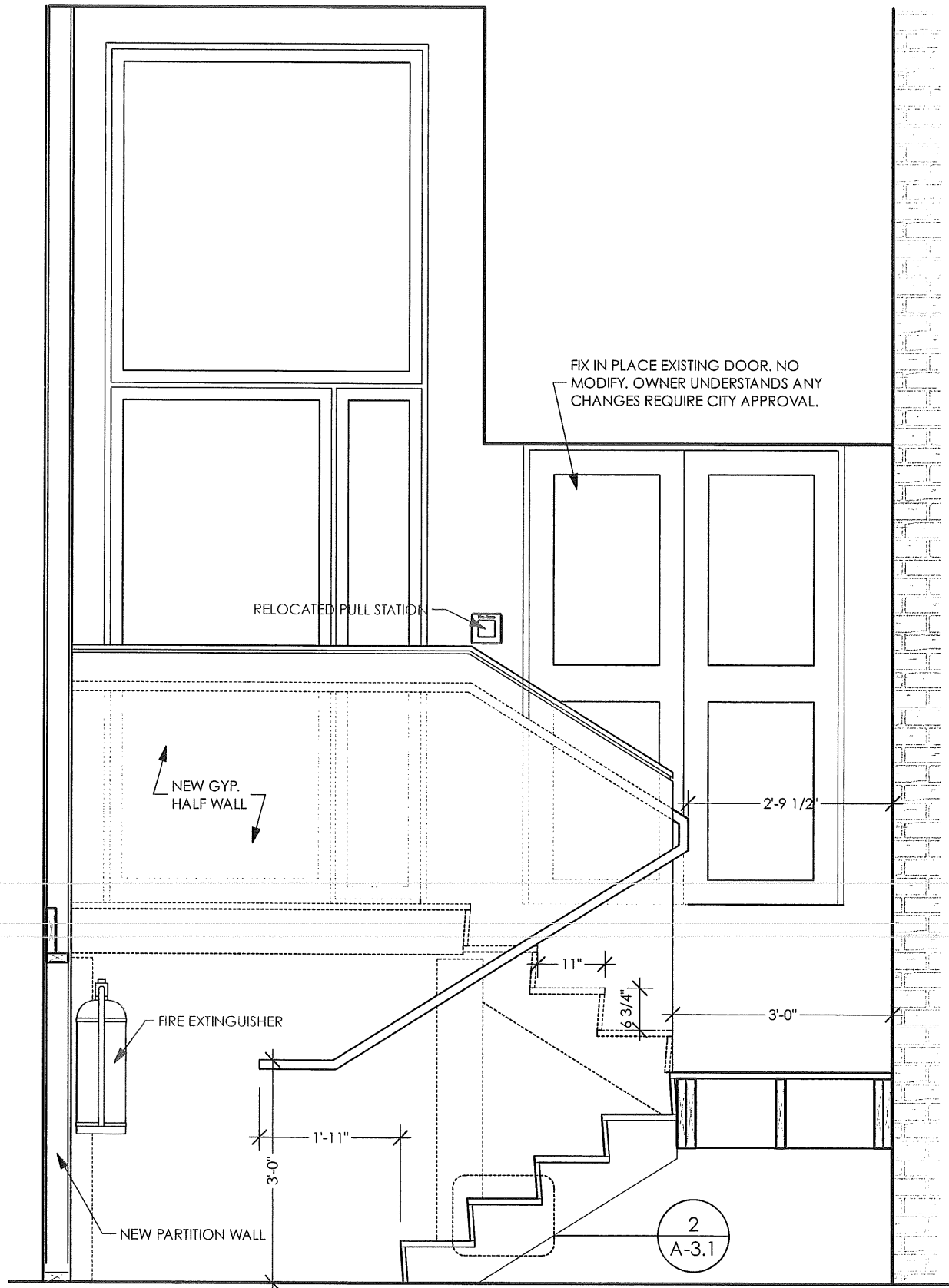

1 STAIR SECTION
SCALE: 1/2" = 1'-0"

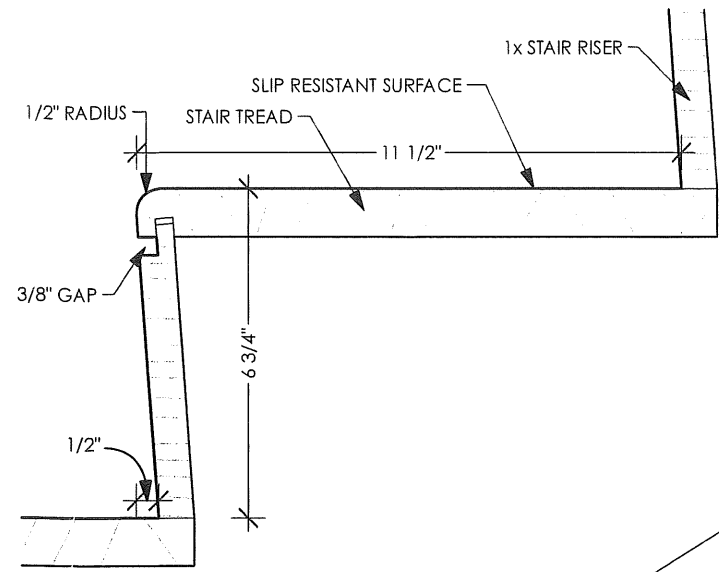

2 STAIR DETAIL
SCALE: 3" = 1'-0"

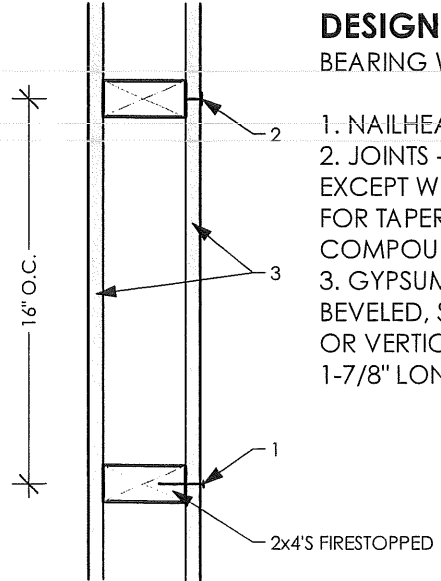

3 1 HR RATED WALL
SCALE: 1 1/2" = 1'-0"

DESIGN # U305
BEARING WALL RATING - 1 HR

1. NAILHEADS - EXPOSED OR COVERED W/ JOINT COMPOUND.
2. JOINTS - EXPOSED OR COVERED W/ FIBER TAPE AND JOINT COMPOUND, EXCEPT WHERE REQUIRED FOR SPECIFIC EDGE CONFIGURATION. FOR TAPERED, ROUNDED-EDGE WALLBOARD, JOINTS COVERED WITH JOINT COMPOUND OR FIBER TAPE AND JOINT COMPOUND. JOINTS REINFORCED.
3. GYPSUM BOARD - 5/8" THICK WALLBOARD PAPER OR VINYL SURFACED, WITH BEVELED, SQUARE, OR TAPERED EDGES, APPLIED EITHER HORIZONTALLY OR VERTICALLY. WALLBOARD NAILED 7" O.C. W/ 6d CEMENT COATED NAILS 1-7/8" LONG, 0.0915" SHANK dia AND 1/4" DIAM HEADS.



See Revisions 1/4/13

A-3.1 SECTION & DETAILS
THOMAS CAFE
DARREN THOMAS
66 MARKET ST, PORTLAND, ME 04101

RECEIVED
DEC 19 2012
Dept. of Building Inspections
City of Portland Maine

DRAFTSPERSON:
CAT SUMISLASKI
DATE OF ISSUE:
12/13/12
PROJECT STATUS:
LIFE SAFETY REVIEW

CALEB JOHNSON ARCHITECTS
265 MAIN ST, UNIT 201, BIDDEFORD, MAINE 04005
T: 207.283.8777 F: 207.283.0087
WWW.CALEBJOHNSONARCHITECTS.COM

Restore Doors

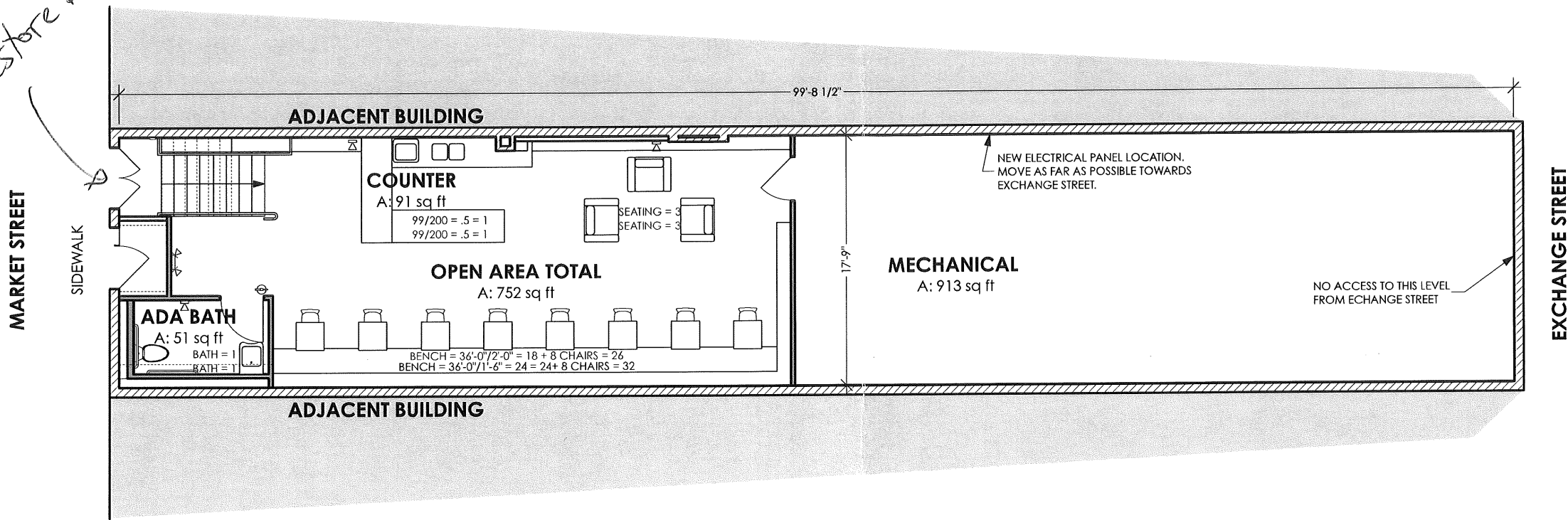

1 SITE PLAN
SCALE: 1/8" = 1'-0"

CALEB JOHNSON ARCHITECTS
265 MAIN ST. UNIT 201, BIDDEFORD, MAINE 04005
T: 207.283.8777 F: 207.283.0087
WWW.CALEBJOHNSONARCHITECTS.COM

DRAFTSPERSON:
CAT SUMILASKI
DATE OF ISSUE:
1/3/13
PROJECT STATUS:
LIFE SAFETY REVIEW

See Revisions 1/28/13

RECEIVED
JAN 04 2013
Dept. of Building Inspections
City of Portland Maine

IBC 2009 11.27.12

USES: MERCANTILE M (BOOKSTORE) & ASSEMBLY A-2 (CAFE) WHERE ASSEMBLY TO MORE RESTRICTIVE
OCCUPANCY (EXPLAINED ON FLOOR PLAN) = 30

1. SINGLE EGRESS PERMITTED WHEN OL 49 OR LESS IN A & M & EXISTING BUILDINGS ARE NOT REQUIRED TO HAVE ACCESSIBLE MEANS OF EGRESS.
2. AREA LESS THAN 5,000 SF, OL LESS THAN 100 AND AREA IS LEVEL OF DISCHARGE THEREFORE NO SPRINKLER SYSTEM REQUIRED
3. ONE HOUR RATED CEILING ASSEMBLY REQUIRED BETWEEN ASSEMBLY & MERC, NON FOR MERC TO MERC
4. STAIR HEADROOM NOT LESS THAN 80" AND HANDRAILS REQUIRED ON BOTH SIDES W/ SLIP RESISTANT & SECURED TREADS.
5. OL LESS THAN 50 THEREFORE MIN WIDTH OF STAIR PERMITTED TO BE 36" WITH 4 1/2" HANDRAIL PROTRUSION FROM WALL.
6. HEADROOM 7'-6" MINIMUM W/ PROJECTIONS NOT LESS THAN 6'-8" ABOVE FLOOR.

NFPA 101 2009 11.28.12

USES: MERCANTILE CLASS C AS ASSEMBLY DEFINED AS GATHERING OF 50 OR MORE
OCCUPANCY (EXPLAINED ON FLOOR PLAN) = 36

1. SINGLE EGRESS PERMITTED IN M CLASS C WHEN TRAVEL DISTANCE LESS THAN 75 FT.
2. SIZE OF SCOPE IS SMALLER THAN REQUIREMENTS THEREFORE NO SPRINKLER SYSTEM REQUIRED
3. NO RATED ASSEMBLY REQUIRED WHEN M ABOVE AND PROJECT IS M.
4. STAIR HEADROOM NOT LESS THAN 80" AND HANDRAILS REQUIRED ON BOTH SIDES W/ SLIP RESISTANT & SECURE TREADS.
5. OL LESS THAN 50 THEREFORE WITH OF STAIR PERMITTED TO BE 36" W/ 4 1/2" HANDRAIL PROTRUSION FROM WALL.
6. STAIR TREADS SHALL ALSO BE FREE OF PROTRUSIONS OR LIPS THAT COULD TRIP STAIR USER.
7. HEADROOM 7'-0" MINIMUM IN EXISTING BUILDINGS W/ PROJECTIONS NOT LESS THAN 6'-8" ABOVE FLOOR.
8. EXIT DOOR IN M CLASS C PERMITTED TO SWING INWARD AS IT IS LEVEL OF DISCHARGE.

A-1.0 SITE PLAN

THOMAS CAFE

DARREN THOMAS
66 MARKET ST. PORTLAND, ME 04101

1 GROUND FLOOR
SCALE: 1/4" = 1'-0"

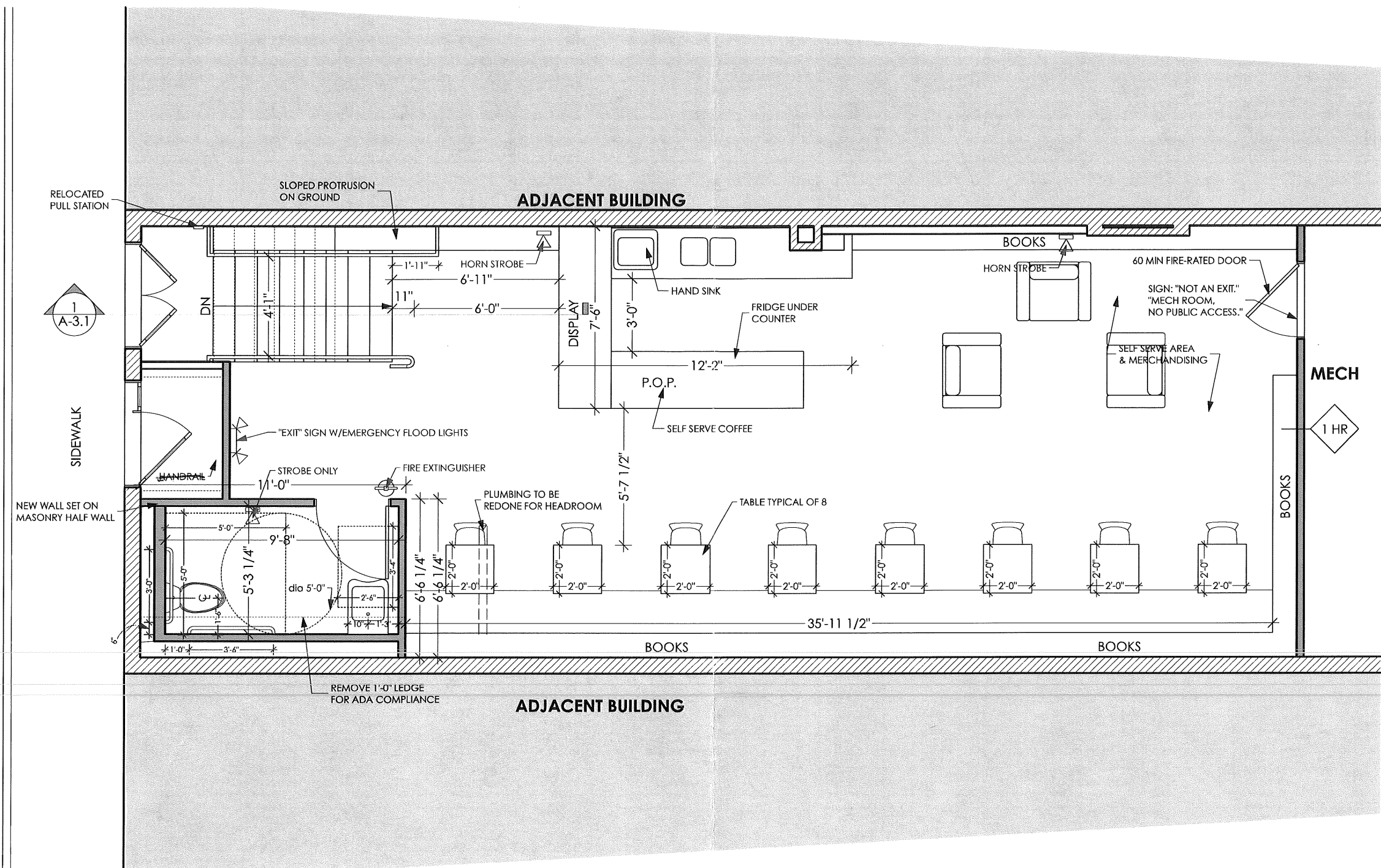

- NOTES:**
1. CEILING TO BE SMOKE TIGHT.
 2. DEMOLISH ALL EXISTING EXPOSED SPRINKLER PIPES AND HEADS.

A-1.1 FLOOR PLAN
THOMAS CAFE
DARREN THOMAS
66 MARKET ST, PORTLAND, ME 04101

DRAFTSPERSON:
CAT SUMISLASKI
DATE OF ISSUE:
1/3/13
PROJECT STATUS:
LIFE SAFETY REVIEW

See Revisions 1/28/13

RECEIVED
JAN 04 2013
Dept. of Building Inspections
City of Portland Maine

CALEB JOHNSON ARCHITECTS
265 MAIN ST. UNIT 201, BIDDEFORD, MAINE 04005
T: 207.283.8777 F: 207.283.0087
WWW.CALEBJOHNSONARCHITECTS.COM

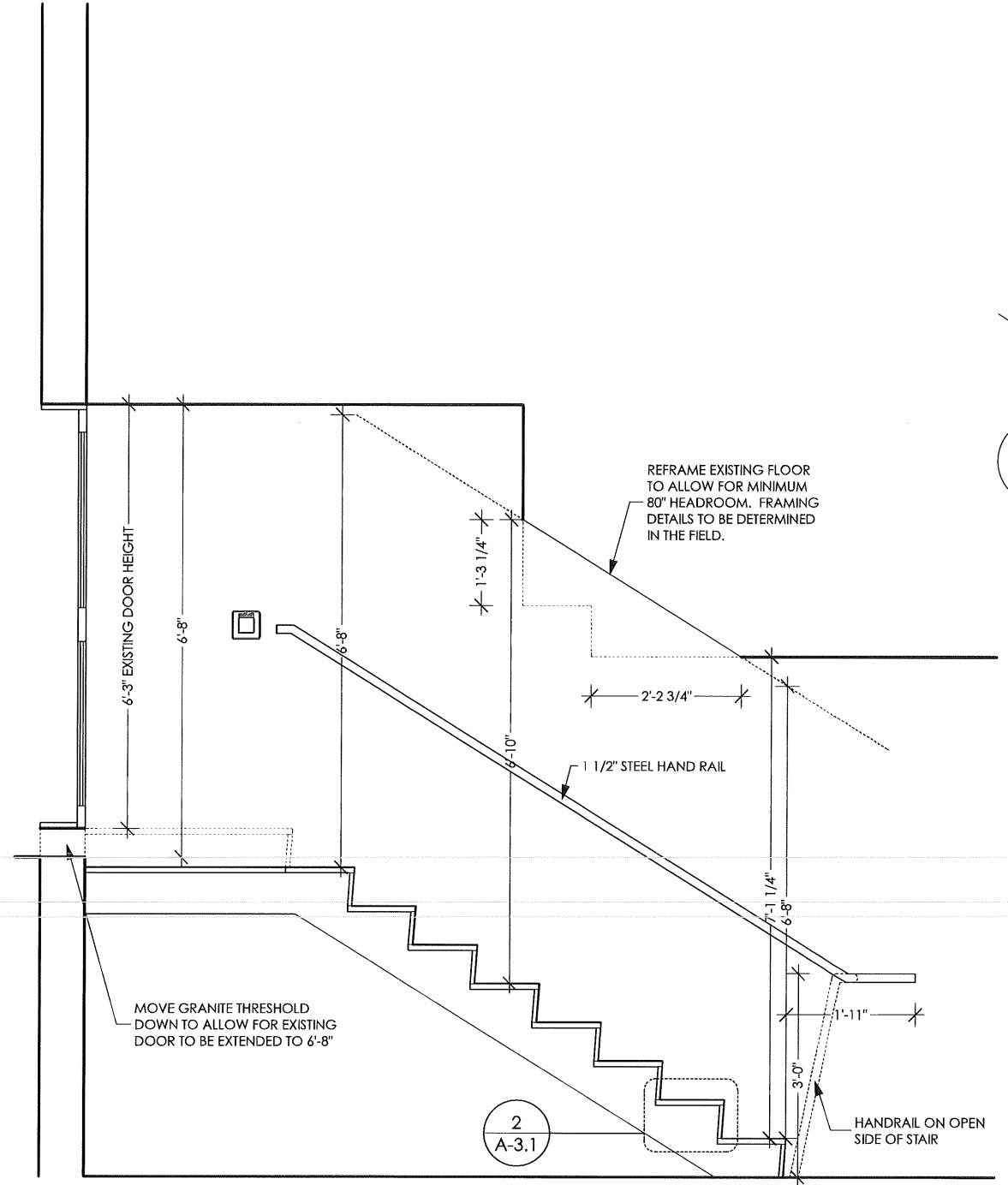

1 STAIR SECTION
SCALE: 1/2" = 1'-0"

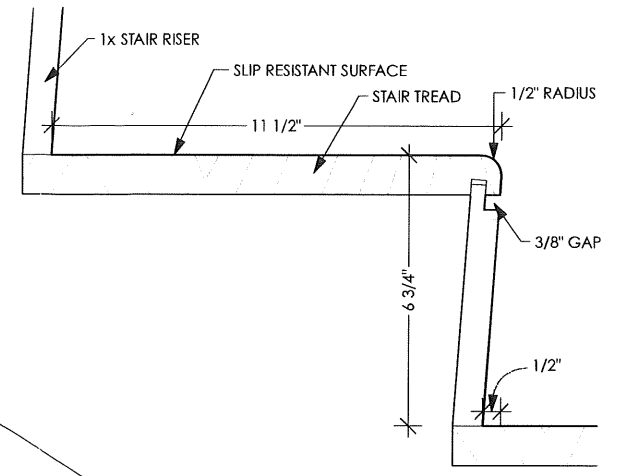

2 STAIR DETAIL
SCALE: 3" = 1'-0"

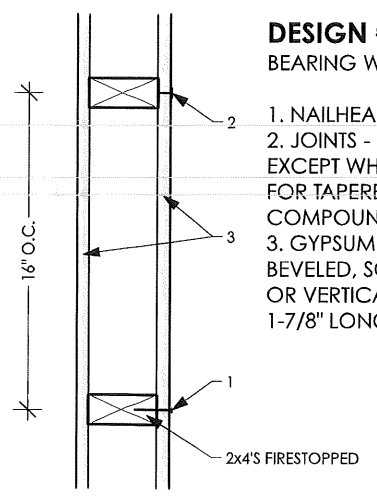

3 1 HR RATED WALL
SCALE: 1 1/2" = 1'-0"

DESIGN # U305
BEARING WALL RATING - 1 HR

1. NAILHEADS - EXPOSED OR COVERED W/ JOINT COMPOUND.
2. JOINTS - EXPOSED OR COVERED W/ FIBER TAPE AND JOINT COMPOUND, EXCEPT WHERE REQUIRED FOR SPECIFIC EDGE CONFIGURATION. FOR TAPERED, ROUNDED-EDGE WALLBOARD, JOINTS COVERED WITH JOINT COMPOUND OR FIBER TAPE AND JOINT COMPOUND. JOINTS REINFORCED.
3. GYPSUM BOARD - 5/8" THICK WALLBOARD PAPER OR VINYL SURFACED, WITH BEVELED, SQUARE, OR TAPERED EDGES, APPLIED EITHER HORIZONTALLY OR VERTICALLY. WALLBOARD NAILED 7" O.C. W/ 6d CEMENT COATED NAILS 1-7/8" LONG, 0.0915" SHANK dia AND 1/4" DIAM HEADS.

CALEB JOHNSON ARCHITECTS
265 MAIN ST. UNIT 201, BIDDEFORD, MAINE 04005
T: 207.283.8777 F: 207.283.0087
WWW.CALEBJOHNSONARCHITECTS.COM

DRAFTERPERSON:
CAT SUMISLASKI
DATE OF ISSUE:
1/3/13
PROJECT STATUS:
LIFE SAFETY REVIEW

See Revisions 1/28/13
JAN 4 2013 RECEIVED
Dept. of Building Inspections
City of Portland Maine

A-3.1 SECTION & DETAILS
THOMAS CAFE
DARREN THOMAS
66 MARKET ST, PORTLAND, ME 04101

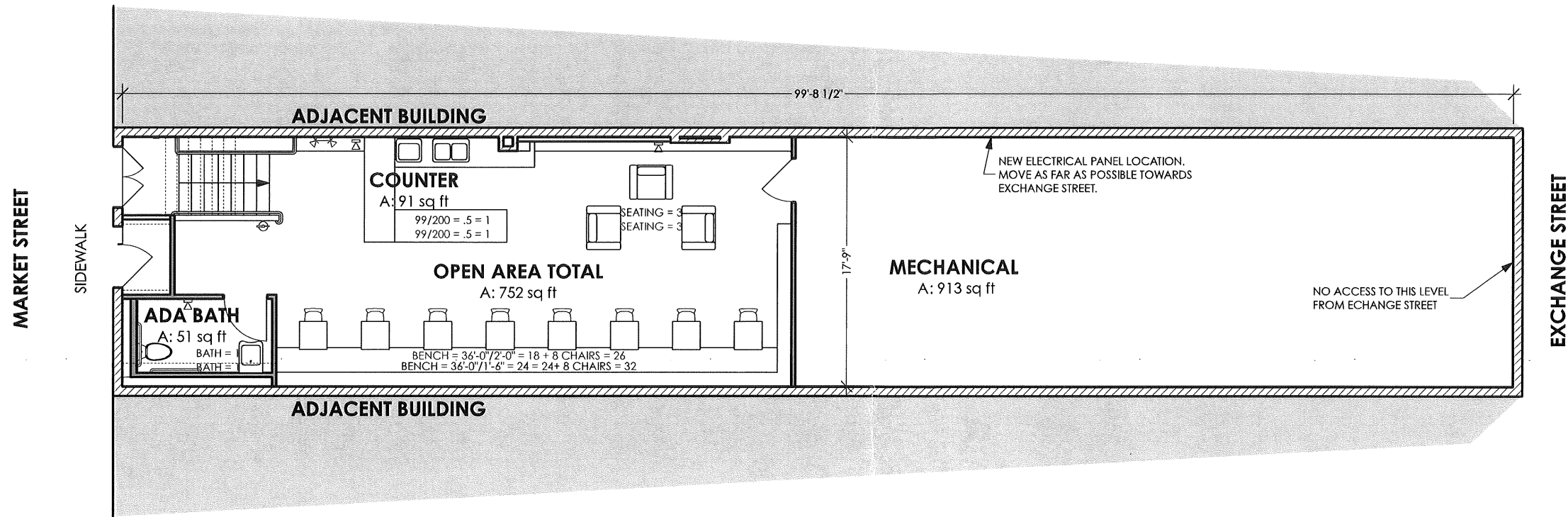

1 SITE PLAN
SCALE: 1/8" = 1'-0"

CALEB JOHNSON ARCHITECTS
265 MAIN ST. UNIT 201, BIDDEFORD, MAINE 04005
T: 207.283.8777 F: 207.283.0087
WWW.CALEBJOHNSONARCHITECTS.COM

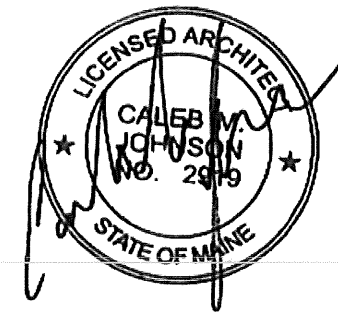

DRAFTSPERSON:
CAT SUMISLASKI
DATE OF ISSUE:
1/25/13
PROJECT STATUS:
LIFE SAFETY REVIEW

IBC 2009 11.27.12

USES: MERCANTILE M (BOOKSTORE) & ASSEMBLY A-2 (CAFE) WHERE ASSEMBLY TO MORE RESTRICTIVE
OCCUPANCY (EXPLAINED ON FLOOR PLAN) = 30

1. SINGLE EGRESS PERMITTED WHEN OL 49 OR LESS IN A & M & EXISTING BUILDINGS ARE NOT REQUIRED TO HAVE ACCESSIBLE MEANS OF EGRESS.
2. AREA LESS THAN 5,000 SF, OL LESS THAN 100 AND AREA IS LEVEL OF DISCHARGE THEREFORE NO SPRINKLER SYSTEM REQUIRED
3. (NOT USED)
4. STAIR HEADROOM NOT LESS THAN 80" AND HANDRAILS REQUIRED ON BOTH SIDES W/ SLIP RESISTANT & SECURED TREADS.
5. OL LESS THAN 50 THEREFORE MIN WIDTH OF STAIR PERMITTED TO BE 36" WITH 4 1/2" HANDRAIL PROTRUSION FROM WALL.
6. HEADROOM 7'-6" MINIMUM W/ PROJECTIONS NOT LESS THAN 6'-8" ABOVE FLOOR.

NFPA 101 2009 11.28.12

USES: MERCANTILE CLASS C AS ASSEMBLY DEFINED AS GATHERING OF 50 OR MORE OCCUPANCY (EXPLAINED ON FLOOR PLAN) = 36

1. SINGLE EGRESS PERMITTED IN M CLASS C WHEN TRAVEL DISTANCE LESS THAN 75 FT.
2. SIZE OF SCOPE IS SMALLER THAN REQUIREMENTS THEREFORE NO SPRINKLER SYSTEM REQUIRED
3. NO RATED ASSEMBLY REQUIRED WHEN M ABOVE AND PROJECT IS M.
4. STAIR HEADROOM NOT LESS THAN 80" AND HANDRAILS REQUIRED ON BOTH SIDES W/ SLIP RESISTANT & SECURE TREADS. AT LANDING HEADROOM NO LESS THAN 7'-0" IN EXISTING BUILDINGS.
5. OL LESS THAN 50 THEREFORE WITH OF STAIR PERMITTED TO BE 36" W/ 4 1/2" HANDRAIL PROTRUSION FROM WALL.
6. STAIR TREADS SHALL ALSO BE FREE OF PROTRUSIONS OR LIPS THAT COULD TRIP STAIR USER.
7. HEADROOM 7'-0" MINIMUM IN EXISTING BUILDINGS W/ PROJECTIONS NOT LESS THAN 6'-8" ABOVE FLOOR.
8. EXIT DOOR IN M CLASS C PERMITTED TO SWING INWARD AS IT IS LEVEL OF DISCHARGE.

A-1.0 SITE PLAN

THOMAS CAFE
DARREN THOMAS
66 MARKET ST. PORTLAND, ME 04101

RECEIVED
JAN 28 2013
Dept. of Building Inspections
City of Portland Maine

MARKET STREET

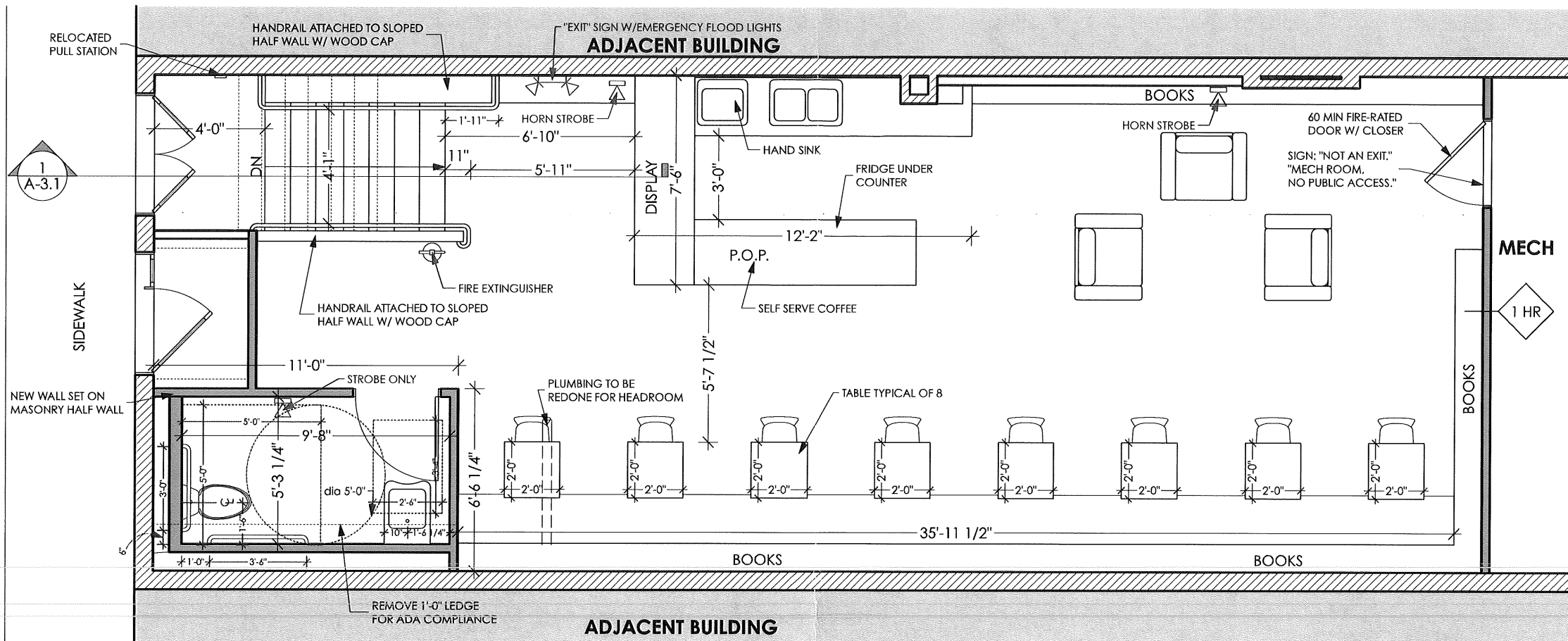

1 GROUND FLOOR
SCALE: 1/4" = 1'-0"

CALEB JOHNSON ARCHITECTS
265 MAIN ST. UNIT 201, BIDDEFORD, MAINE 04005
T: 207.283.8777 F: 207.283.0087
WWW.CALEBJOHNSONARCHITECTS.COM

DRAFTSPERSON:
CAT SUMISLASKI
DATE OF ISSUE:
1/25/13
PROJECT STATUS:
LIFE SAFETY REVIEW

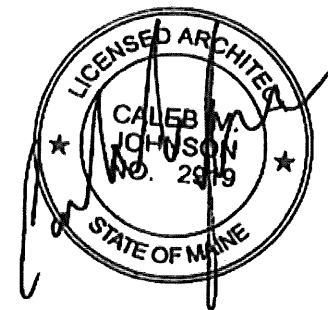

- NOTES:**
1. CEILING TO BE SMOKE TIGHT.
 2. DEMOLISH ALL EXISTING EXPOSED SPRINKLER PIPES AND HEADS.

A-1.1 FLOOR PLAN
THOMAS CAFE
DARREN THOMAS
66 MARKET ST, PORTLAND, ME 04101

RECEIVED
JAN 28 2013
Dept. of Building Inspections
City of Portland Maine

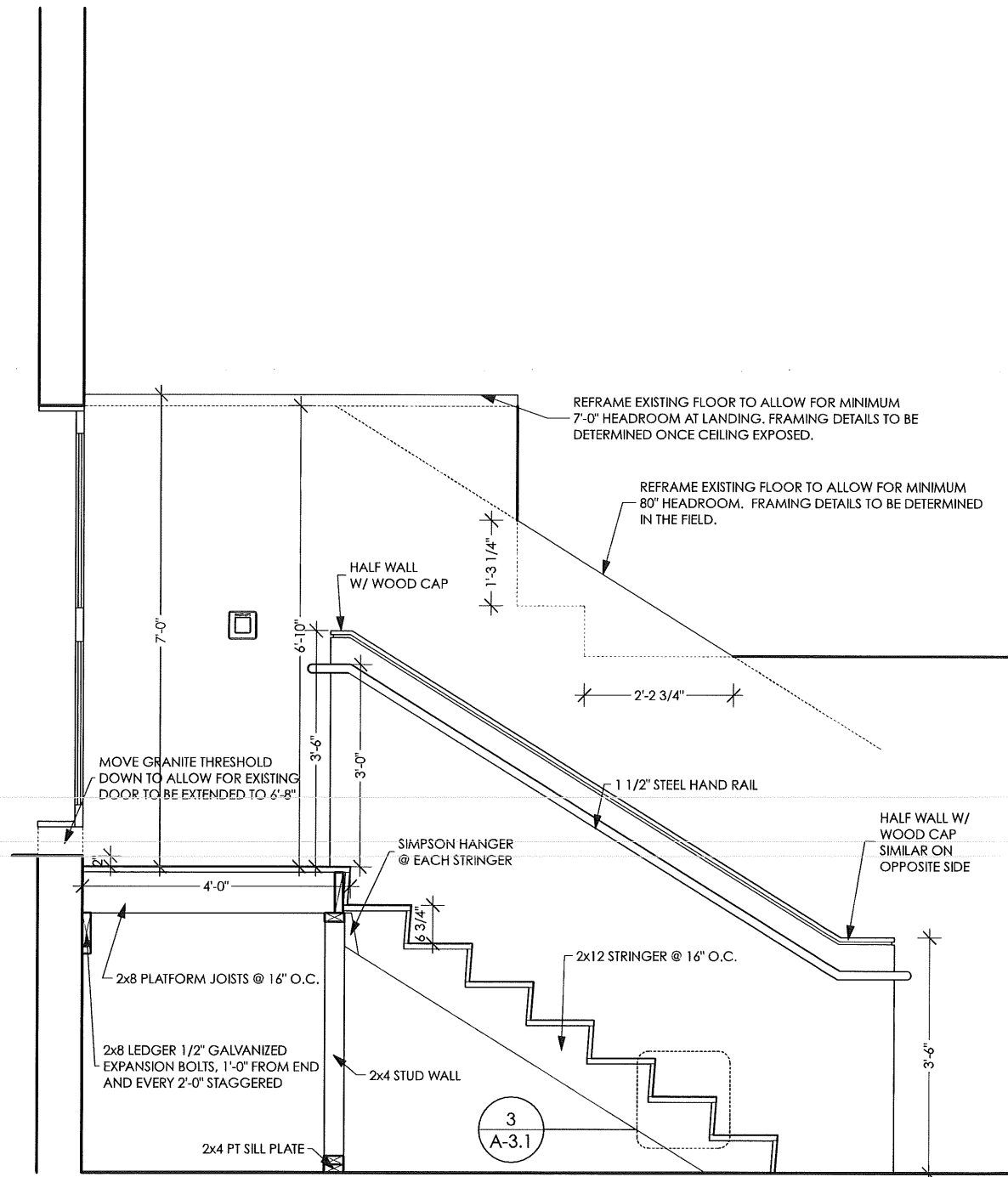

1 STAIR SECTION
SCALE: 1/2" = 1'-0"

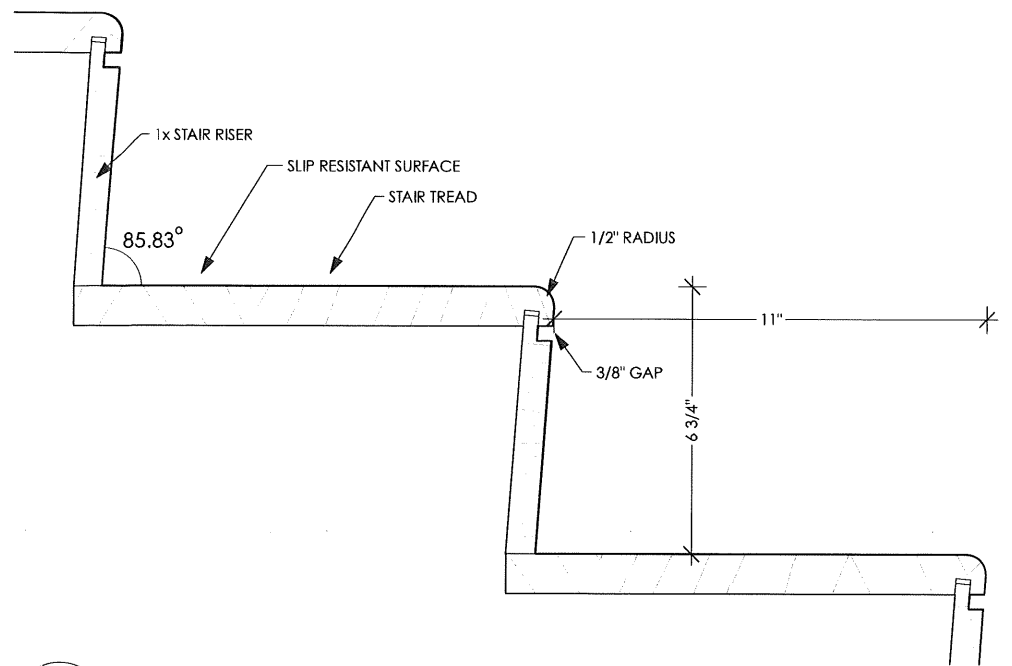

3 STAIR DETAIL
SCALE: 3" = 1'-0"

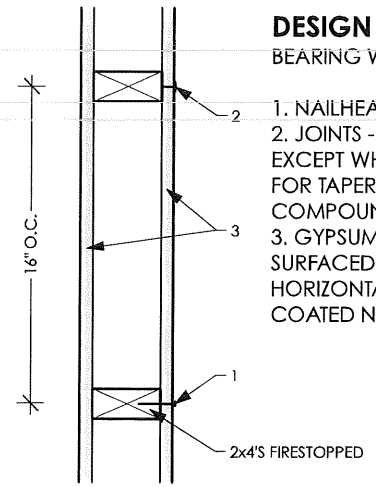

4 1 HR RATED WALL
SCALE: 1 1/2" = 1'-0"

DESIGN # U305

BEARING WALL RATING - 1 HR

1. NAILHEADS - EXPOSED OR COVERED W/ JOINT COMPOUND.
2. JOINTS - EXPOSED OR COVERED W/ FIBER TAPE AND JOINT COMPOUND, EXCEPT WHERE REQUIRED FOR SPECIFIC EDGE CONFIGURATION. FOR TAPERED, ROUNDED-EDGE WALLBOARD, JOINTS COVERED WITH JOINT COMPOUND OR FIBER TAPE AND JOINT COMPOUND. JOINTS REINFORCED.
3. GYPSUM BOARD - FIRE RATED 5/8" THICK WALLBOARD PAPER OR VINYL SURFACED, WITH BEVELED, SQUARE, OR TAPERED EDGES, APPLIED EITHER HORIZONTALLY OR VERTICALLY. WALLBOARD NAILED 7" O.C. W/ 6d CEMENT COATED NAILS 1-7/8" LONG, 0.0915" SHANK dia AND 1/4" DIAM HEADS.

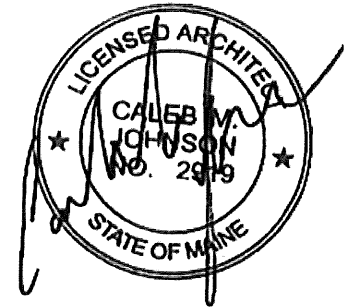

CALEB JOHNSON ARCHITECTS
265 MAIN ST UNIT 201, BIDDEFORD, MAINE 04005
T: 207.283.8777 F: 207.283.0087
WWW.CALEBJOHNSONARCHITECTS.COM

DRAFTSPERSON:
CAT SUMISLASKI
DATE OF ISSUE:
1/25/13
PROJECT STATUS:
LIFE SAFETY REVIEW

A-3.1 SECTION & DETAILS
THOMAS CAFE
DARREN THOMAS
66 MARKET ST. PORTLAND, ME 04101

RECEIVED
JAN 28 2013
Dept. of Building Inspections
City of Portland Maine

RECEIVED
JAN 28 2013
Dept. of Building Inspections
City of Portland Maine

MARKET STREET

SIDEWALK

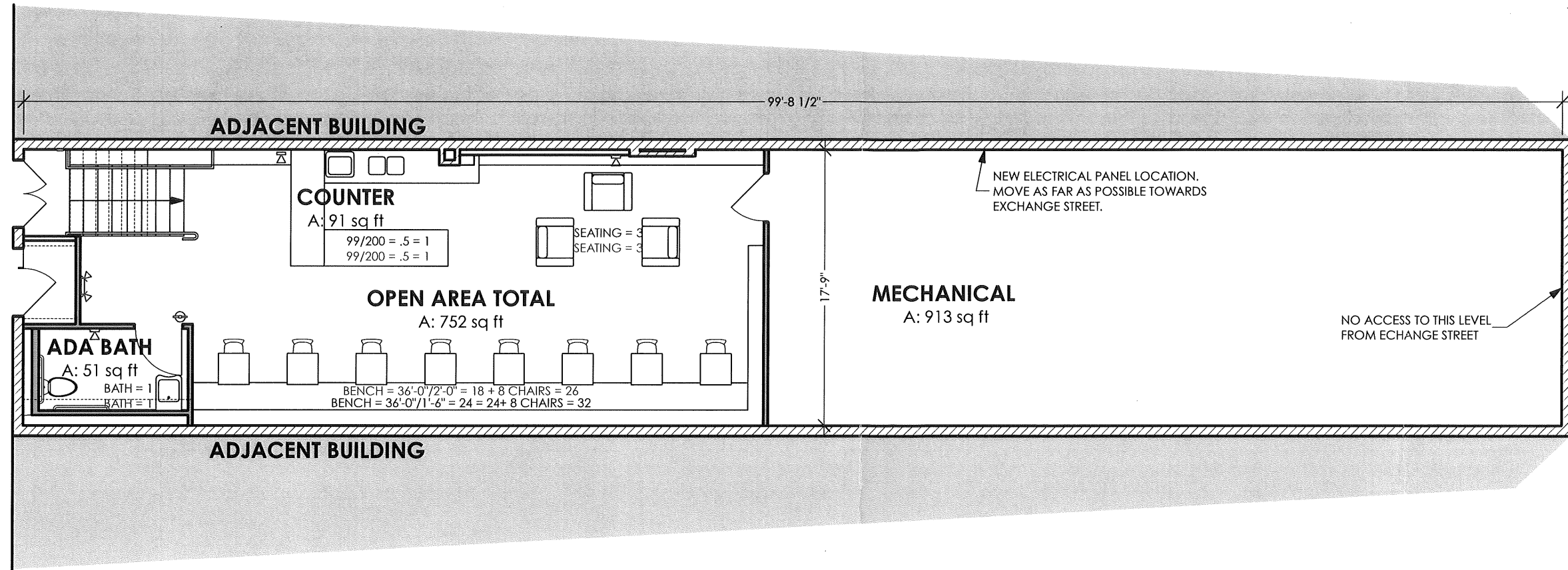

EXCHANGE STREET

1 SITE PLAN
SCALE: 1/8" = 1'-0"

DRAFTSPERSON:
CAT SUMSLASKI
DATE OF ISSUE:
1/3/13
PROJECT STATUS:
LIFE SAFETY REVIEW

CALEB JOHNSON ARCHITECTS
265 MAIN ST. UNIT 201, BIDDEFORD, MAINE 04005
T: 207.283.8777 F: 207.283.0087
WWW.CALEBJOHNSONARCHITECTS.COM

IBC 2009 11.27.12

USES: MERCANTILE M (BOOKSTORE) & ASSEMBLY A-2 (CAFE) WHERE ASSEMBLY TO MORE RESTRICTIVE
OCCUPANCY (EXPLAINED ON FLOOR PLAN) = 30

1. SINGLE EGRESS PERMITTED WHEN OL 49 OR LESS IN A & M & EXISTING BUILDINGS ARE NOT REQUIRED TO HAVE ACCESSIBLE MEANS OF EGRESS.
2. AREA LESS THAN 5,000 SF, OL LESS THAN 100 AND AREA IS LEVEL OF DISCHARGE THEREFORE NO SPRINKLER SYSTEM REQUIRED
3. ONE HOUR RATED CEILING ASSEMBLY REQUIRED BETWEEN ASSEMBLY & MERC, NON FOR MERC TO MERC
4. STAIR HEADROOM NOT LESS THAN 80" AND HANDRAILS REQUIRED ON BOTH SIDES W/ SLIP RESISTANT & SECURED TREADS.
5. OL LESS THAN 50 THEREFORE MIN WIDTH OF STAIR PERMITTED TO BE 36" WITH 4 1/2" HANDRAIL PROTRUSION FROM WALL.
6. HEADROOM 7'-6" MINIMUM W/ PROJECTIONS NOT LESS THAN 6'-8" ABOVE FLOOR.

NFPA 101 2009 11.28.12

USES: MERCANTILE CLASS C AS ASSEMBLY DEFINED AS GATHERING OF 50 OR MORE OCCUPANCY (EXPLAINED ON FLOOR PLAN) = 36

1. SINGLE EGRESS PERMITTED IN M CLASS C WHEN TRAVEL DISTANCE LESS THAN 75 FT.
2. SIZE OF SCOPE IS SMALLER THAN REQUIREMENTS THEREFORE NO SPRINKLER SYSTEM REQUIRED
3. NO RATED ASSEMBLY REQUIRED WHEN M ABOVE AND PROJECT IS M.
4. STAIR HEADROOM NOT LESS THAN 80" AND HANDRAILS REQUIRED ON BOTH SIDES W/ SLIP RESISTANT & SECURED TREADS.
5. OL LESS THAN 50 THEREFORE WITH OF STAIR PERMITTED TO BE 36" W/ 4 1/2" HANDRAIL PROTRUSION FROM WALL.
6. STAIR TREADS SHALL ALSO BE FREE OF PROTRUSIONS OR LIPS THAT COULD TRIP STAIR USER.
7. HEADROOM 7'-0" MINIMUM IN EXISTING BUILDINGS W/ PROJECTIONS NOT LESS THAN 6'-8" ABOVE FLOOR.
8. EXIT DOOR IN M CLASS C PERMITTED TO SWING INWARD AS IT IS LEVEL OF DISCHARGE.

A-1.0 SITE PLAN
THOMAS CAFE
DARREN THOMAS
66 MARKET ST, PORTLAND, ME 04101

MARKET STREET

RELOCATED PULL STATION

SLOPED PROTRUSION ON GROUND

ADJACENT BUILDING

1
A-3.1

SIDEWALK

NEW WALL SET ON MASONRY HALF WALL

"EXIT" SIGN W/EMERGENCY FLOOD LIGHTS

STROBE ONLY

FIRE EXTINGUISHER

PLUMBING TO BE REDONE FOR HEADROOM

TABLE TYPICAL OF 8

35'-11 1/2"

BOOKS

BOOKS

REMOVE 1'-0" LEDGE FOR ADA COMPLIANCE

ADJACENT BUILDING

BOOKS

HORN STROBE

60 MIN FIRE-RATED DOOR

SIGN: "NOT AN EXIT."
"MECH ROOM,
NO PUBLIC ACCESS."

SELF SERVE AREA
& MERCHANDISING

MECH

1 HR

BOOKS

1'-11"
6'-11"
6'-0"
11"
4'-1"
DN
7'-6"
3'-0"
12'-2"
P.O.P.
HAND SINK
FRIDGE UNDER COUNTER
SELF SERVE COFFEE

5'-0"
9'-8"
5'-3 1/4"
dia 5'-0"
2'-6"
10'-1-3"
3'-0"
1'-0"
3'-6"
6'-6 1/4"
6'-6 1/4"
2'-0"
2'-0"
2'-0"
2'-0"
2'-0"
2'-0"
2'-0"
2'-0"
2'-0"
2'-0"

CALEB JOHNSON ARCHITECTS
265 MAIN ST. UNIT 201, BIDDEFORD, MAINE 04005
T: 207.283.8777 F: 207.283.0087
WWW.CALEBJOHNSONARCHITECTS.COM

DRAFTSPERSON:
CAT SUMILASKI
DATE OF ISSUE:
1/3/13
PROJECT STATUS:
LIFE SAFETY REVIEW

1

GROUND FLOOR
SCALE: 1/4" = 1'-0"

NOTES:

- 1. CEILING TO BE SMOKE TIGHT.
- 2. DEMOLISH ALL EXISTING EXPOSED SPRINKLER PIPES AND HEADS.

A-1.1 FLOOR PLAN

THOMAS CAFE

DARREN THOMAS
66 MARKET ST, PORTLAND, ME 04101

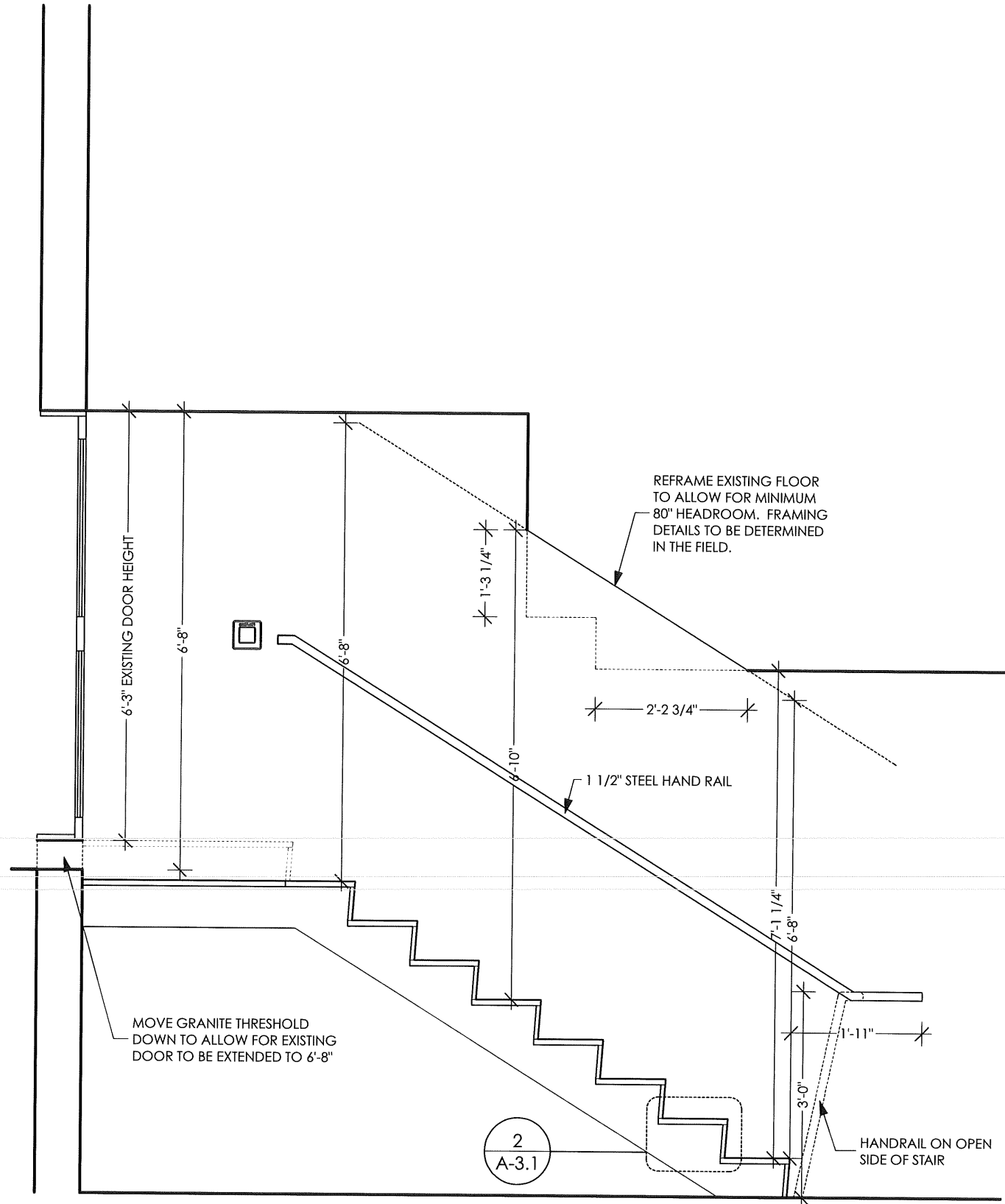

1 STAIR SECTION
SCALE: 1/2" = 1'-0"

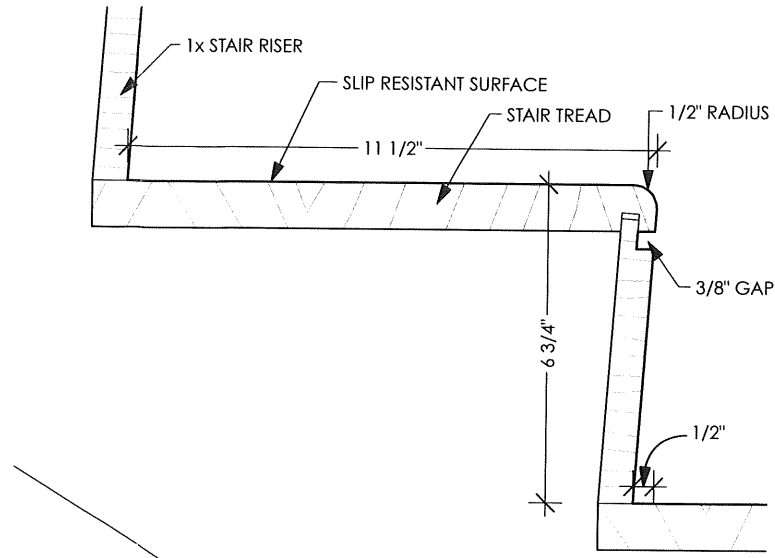

2 STAIR DETAIL
SCALE: 3" = 1'-0"

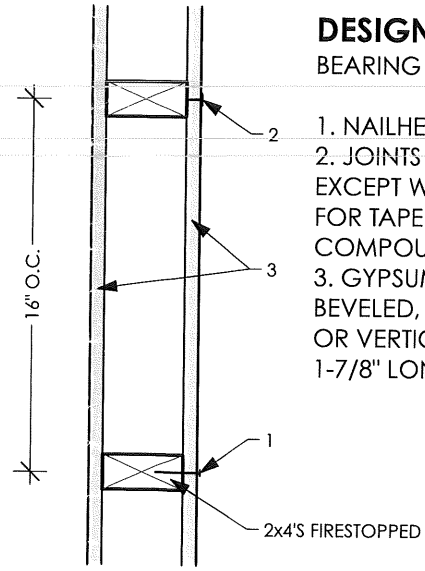

3 1 HR RATED WALL
SCALE: 1 1/2" = 1'-0"

DESIGN # U305
BEARING WALL RATING - 1 HR

1. NAILHEADS - EXPOSED OR COVERED W/ JOINT COMPOUND.
2. JOINTS - EXPOSED OR COVERED W/ FIBER TAPE AND JOINT COMPOUND, EXCEPT WHERE REQUIRED FOR SPECIFIC EDGE CONFIGURATION. FOR TAPERED, ROUNDED-EDGE WALLBOARD, JOINTS COVERED WITH JOINT COMPOUND OR FIBER TAPE AND JOINT COMPOUND. JOINTS REINFORCED.
3. GYPSUM BOARD - 5/8" THICK WALLBOARD PAPER OR VINYL SURFACED, WITH BEVELED, SQUARE, OR TAPERED EDGES, APPLIED EITHER HORIZONTALLY OR VERTICALLY. WALLBOARD NAILED 7" O.C. W/ 6d CEMENT COATED NAILS 1-7/8" LONG, 0.0915" SHANK dia AND 1/4" DIAM HEADS.

A-3.1 SECTION & DETAILS
THOMAS CAFE
DARREN THOMAS
66 MARKET ST, PORTLAND, ME 04101

DRAFTSPERSON:
CAT SUMISLASKI
DATE OF ISSUE:
1/3/13
PROJECT STATUS:
LIFE SAFETY REVIEW

CALEB JOHNSON ARCHITECTS
265 MAIN ST. UNIT 201, BIDDEFORD, MAINE 04005
T: 207.283.8777 F: 207.283.0087
WWW.CALEBJOHNSONARCHITECTS.COM