

EQUIPMENT SCHEDULE					
ITEM	QTY.	MODEL	DESCRIPTION	GAS	ELEC.
1	1	C83G-3G-0	5/8 WORKTOP W/ OPEN CABINET BASE		
2	1	C083G-1-1	VALVE CONTROLLED GRIDDLE W/ CABINET BASE	90,000	
3	1	C83G-1-35F	SINGLE RANGE MATCH FRYER	110,000	
4	1	C83G-FMD	RANGE MATCH DUMP STATION W/ CABINET BASE		
5	1	CUSTOM	5/8 END WORKTOP W/ OPEN & SERVICES CABINET BASE		
	2	4522421	1" N.P.T. GAS PRESSURE REGULATOR		
	2	2670000	1" N.P.T. GAS SHUT-OFF VALVES		
6	1	C083G-3GA	CHARBROILER W/ CABINET BASE	108,000	
7	1	C83G-6	(6) OPEN BURNERS W/ STANDARD OVEN BASE	220,000	
8	1	C83G-6	(6) OPEN BURNERS W/ STANDARD OVEN BASE	220,000	
9	1	MIR-34C	SALAMANDER BROILER	40,000	
	1	CUSTOM	5/8 TUBULAR OVERSHELF		
	2	CUSTOM	5/8 FLUE RISERS		
	2	CUSTOM	5/8 BACKRISER AND FLUECOVER		
	2	CUSTOM	5/8 COMMON FRONT RAIL		
TOTAL GAS CONSUMPTION : 788,000 BTU / HOUR					
SUGGESTED GAS SUPPLY LINE : 1 1/2" N.P.T. FOR NATURAL GAS					
ELECTRICAL LOADING : NONE					

SYMBOL	DESCRIPTION
Ⓡ	PRESSURE REGULATOR
ⓧ	GAS SHUT-OFF VALVE

NOTES:

- SPECIFY GAS SUPPLY TYPE: NATURAL OR L.P. GAS
- SUGGESTED GAS SUPPLY LINE: 1 1/2" N.P.T. FOR NATURAL GAS

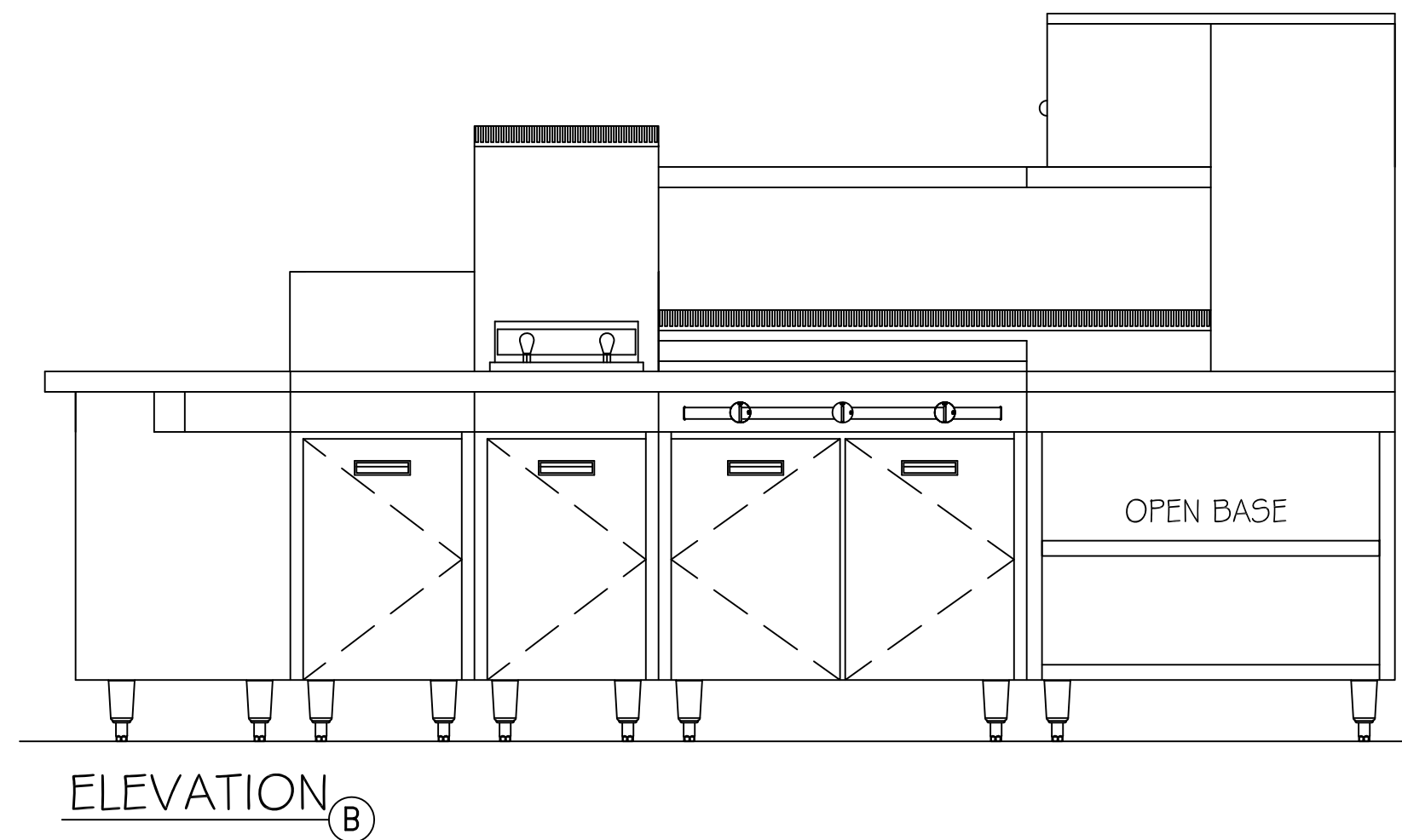
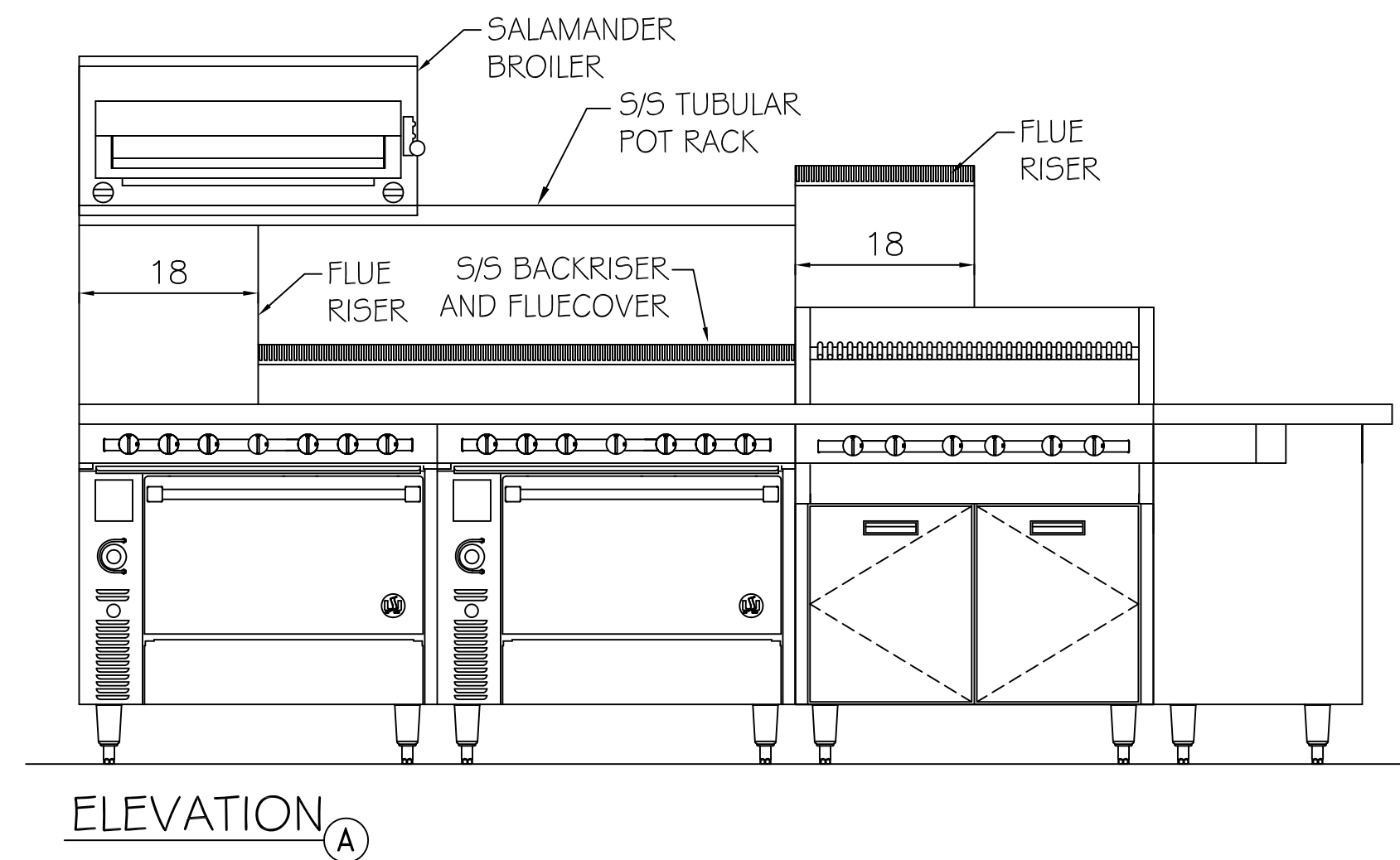

U.S. RANGE CUISINE SERIES

REV.	DESCRIPTION	DATE	BY
<b>REVISIONS</b>			
TOLERANCE ±0.015" UNLESS OTHERWISE SPECIFIED			
ALL DIMENSIONS ARE IN INCHES			
DR: INT.	CHCK BY: D.C.	SCALE: 3/4"=1'-0"	DATE: 10/11/13
TITLE: PRESS HOTEL, PORTLAND, MAINE			
GARLAND U.S. Range			
COMMERCIAL RANGES LIMITED FREELAND, PENNSYLVANIA, USA			
COMMERCIAL RANGES LIMITED MISSISSAUGA, ONT, CANADA			SHT 1 OF 1

Prepared For:  
119 Development, LLC

Consultant:

Architect:  
48 Union Wharf Portland, Maine 04101  
(207) 772-6022 Fax (207) 772-4056

Project:  
PRESS HOTEL  
390 CONGRESS STREET  
PORTLAND, ME 04101

Revisions:  
1 13\_07-01 30% Marriott Submission  
2 13\_09-09 60% Marriott Sub. & Pric.  
3 13\_10-14 Issue for Bid & Marriott Revw.

Date: 10 OCT 13  
Scale: 3/4" = 1'-0"  
Foodservice Equipment  
Range, Island Suite Detail

FS-9