

- PRELIMINARY - NOT FOR CONSTRUCTION
- APPROVED FOR CONSTRUCTION
- SUPERSEDES ALL PREVIOUS ISSUES

BY: *[Signature]* DATE: 11-5-2002

REFERENCE DRAWINGS	
DWG. NO.	TITLE

NOTES:
1. FOR GENERAL AND STEEL NOTES SEE DRAWING D-3006.

LEGEND:
(L3x3) - EXISTING STEEL MEMBER
F.V. - FIELD VERRY

Released For Construction
Date: 11-15-2002

REV.	ISSUED TO	CLIENT	CONSTRUCTION	ISSUED FOR
0				

THIS DRAWING IS THE PROPERTY OF NEILL AND GUNTER. IT IS TO BE USED ONLY FOR THE PROJECT AND SITE SPECIFICALLY IDENTIFIED ON THE DRAWING. NO REUSE OR REPRODUCTION OF THIS DRAWING OR ANY PART THEREOF IS PERMITTED WITHOUT THE WRITTEN CONSENT OF NEILL AND GUNTER.

NO.	DATE	BY	REVISIONS	CHKD.



Neill and Gunter

PORTLAND PRESS HERALD
CONGRESS STREET OFFICE BUILDING

FIRE ESCAPE MAINTENANCE
FIRE ESCAPE NEW BLDG. SUPPORT
LEVELS 4 & 5
PLANS & SECTIONS

JOB NO. 25216 DWG. NO. D-3005

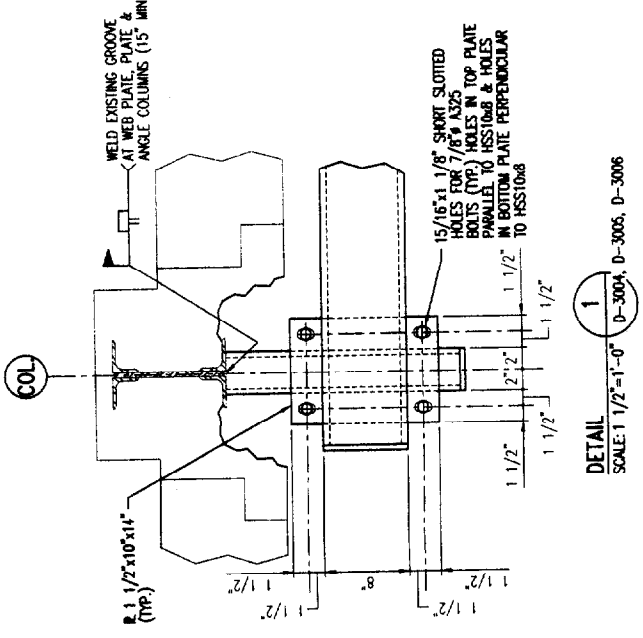
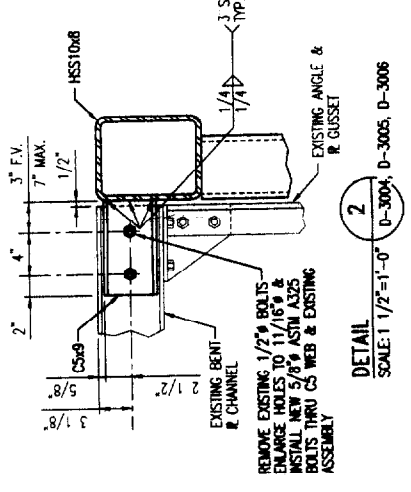
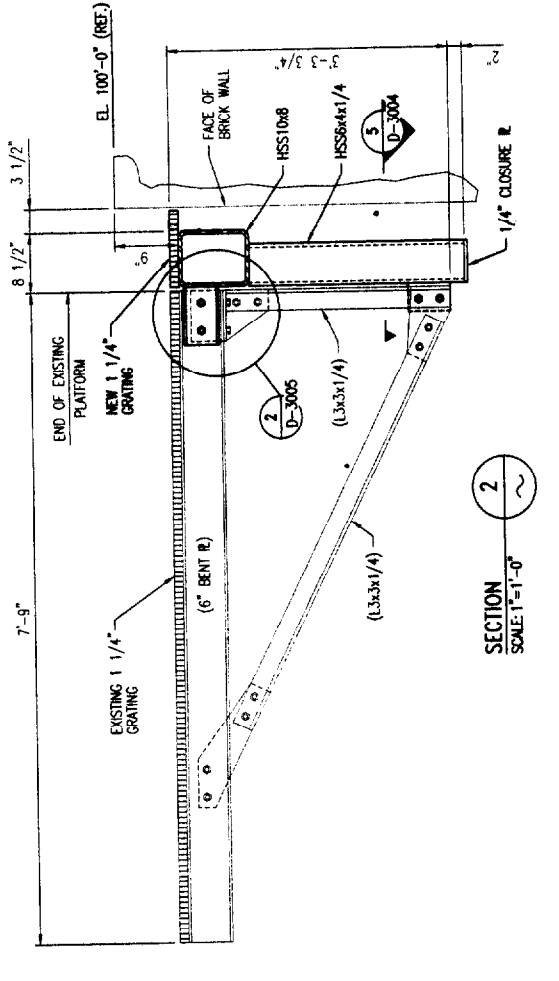
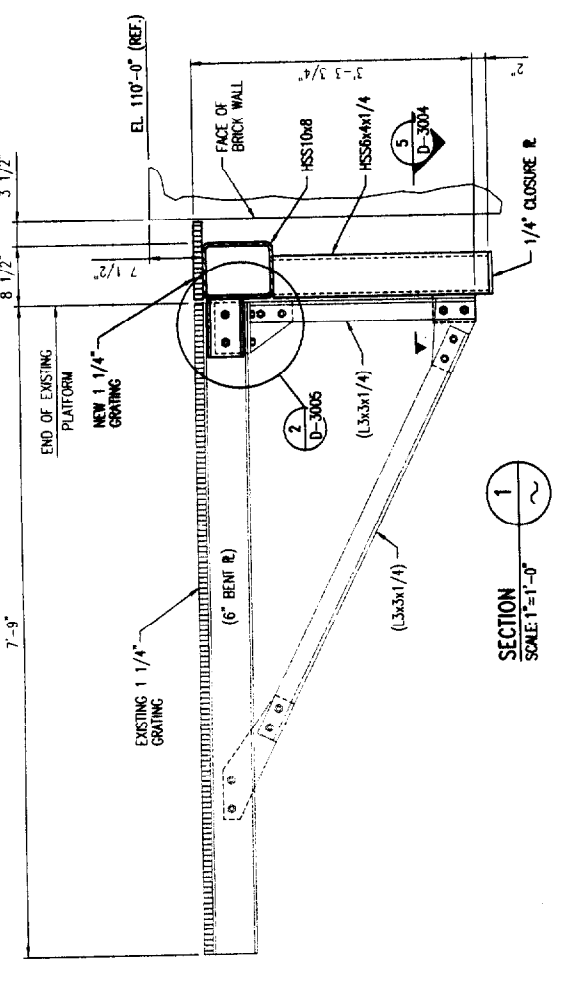

THIS IS AN AUTOCAD FILE TO PRODUCE A SCHEDULE DRAWING. IT MUST BE PLOTTED AT THE INTENDED SCALE.
SCALE: 1/2"=1'-0"

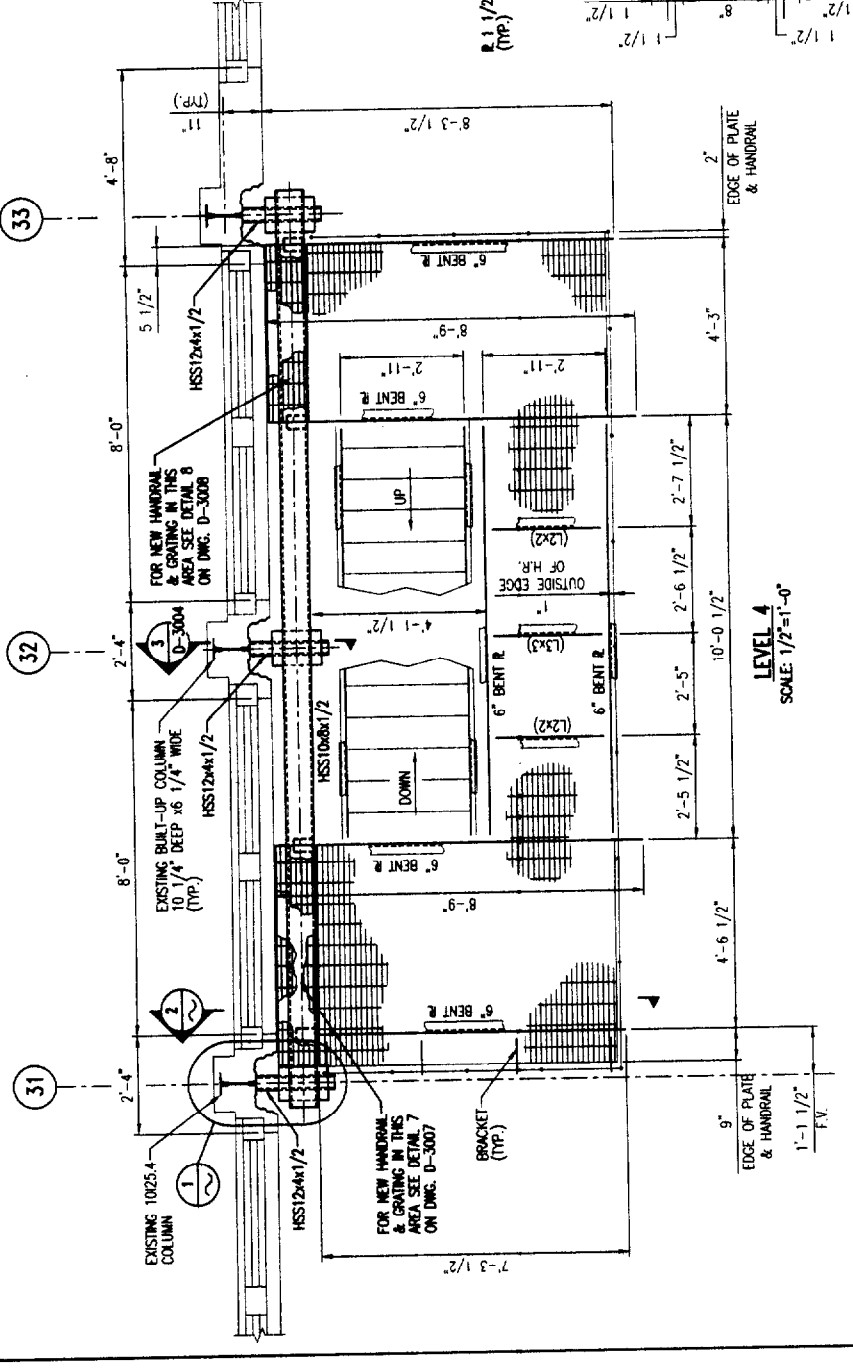
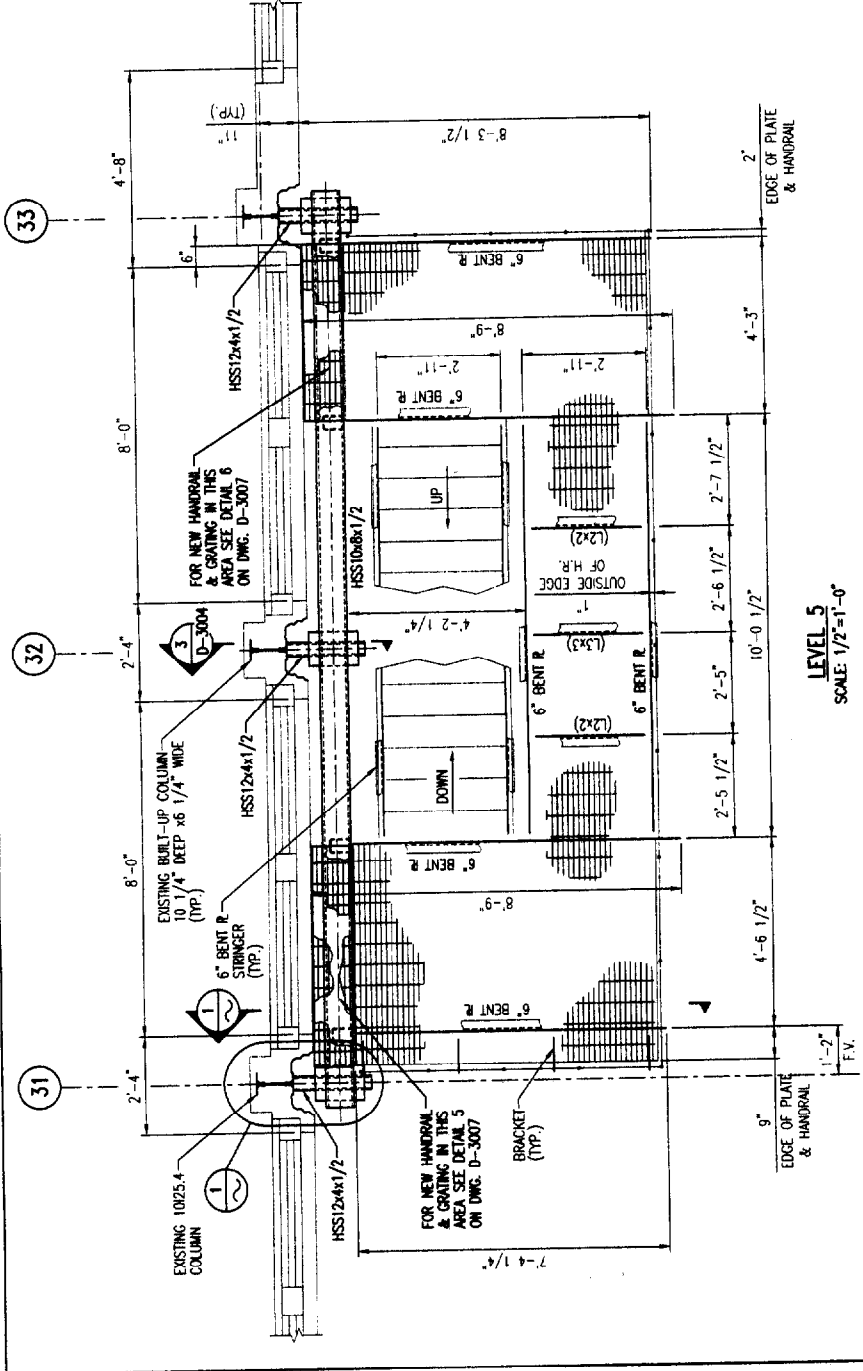

LEVEL 4
SCALE: 1/2"=1'-0"

LEVEL 5
SCALE: 1/2"=1'-0"