

- PRELIMINARY - NOT FOR CONSTRUCTION
- APPROVED FOR CONSTRUCTION
- SUPERSEDES ALL PREVIOUS ISSUES

BY *A. B. Williams* DATE 11/19/2003

NO.	TITLE	BY

LEGEND:
 (L3x3) - EXISTING STEEL MEMBER
 F.V. - FIELD VERRY

Released For Information
 Date: Nov 25, 2003

REV.	ISSUED TO	CLIENT	ISSUED FOR
0			

THIS DRAWING IS THE PROPERTY OF NEILL AND GUNTER. IT IS TO BE USED ONLY FOR THE PROJECT AND SITE SPECIFICALLY IDENTIFIED ON THIS DRAWING. NO PART OF THIS DRAWING IS TO BE REPRODUCED, COPIED OR TRANSMITTED IN ANY FORM OR BY ANY MEANS, WITHOUT THE WRITTEN PERMISSION OF NEILL AND GUNTER.

NO.	DATE	BY	REVISIONS	CKD

NEILL AND GUNTER
 PORTLAND PRESS HERALD
 CONGRESS STREET OFFICE BUILDING
 FIRE ESCAPE MAINTENANCE
 FIRE ESCAPE EXISTING CONDITIONS
 LEVELS 6 & 7
 PLANS & SECTIONS

CPD 25216S001

THIS IS AN AUTOCAD FILE. TO PRODUCE A SCALEABLE DRAWING, IT MUST BE PLOTTED AT THE INTENDED SCALE.

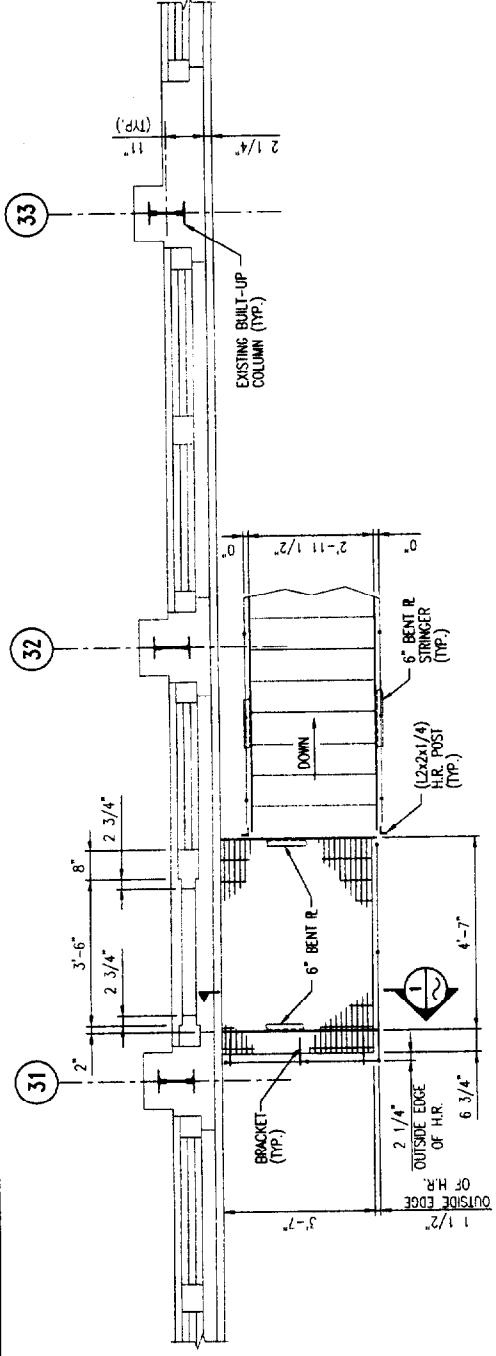

LEVEL 7 - TOP LEVEL
 SCALE: 1/2"=1'-0"

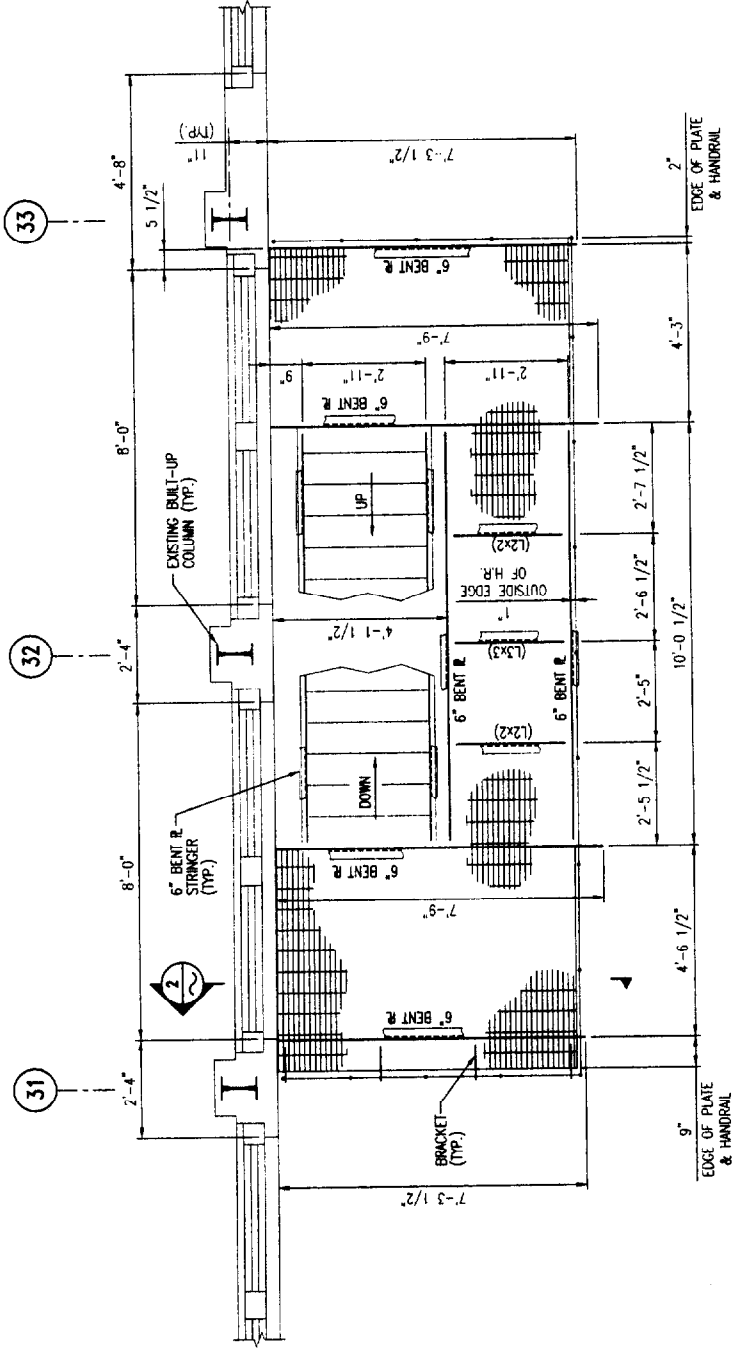

LEVEL 6
 SCALE: 1/2"=1'-0"

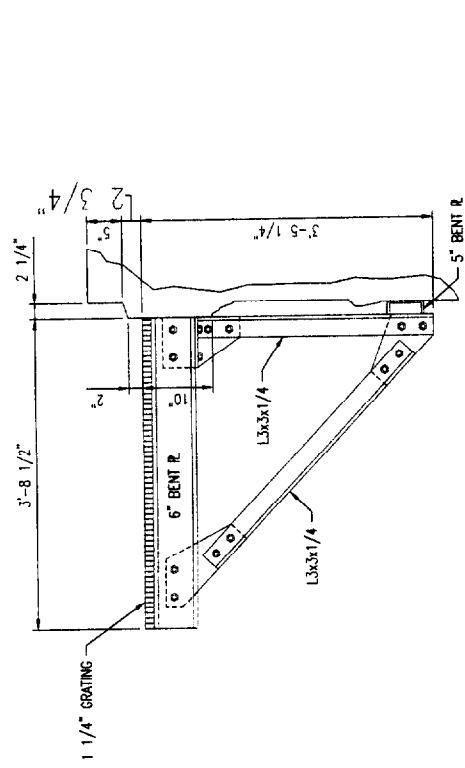

SECTION 1
 SCALE: 1"=1'-0"

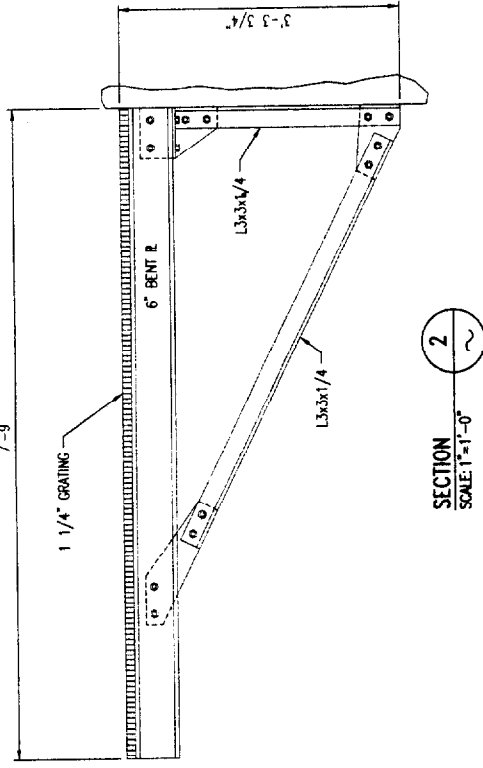

SECTION 2
 SCALE: 1"=1'-0"

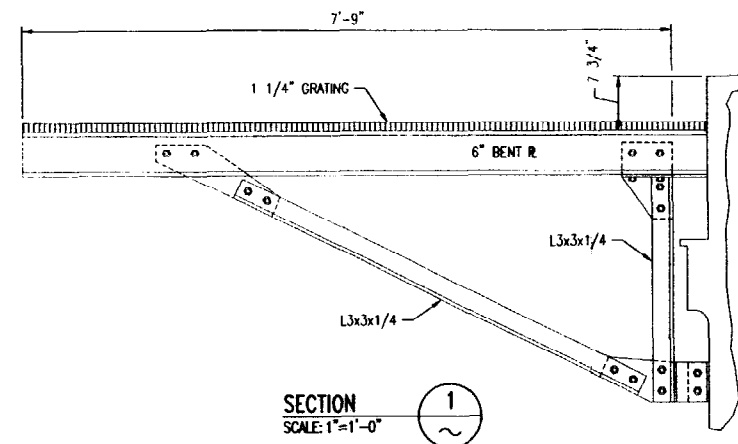
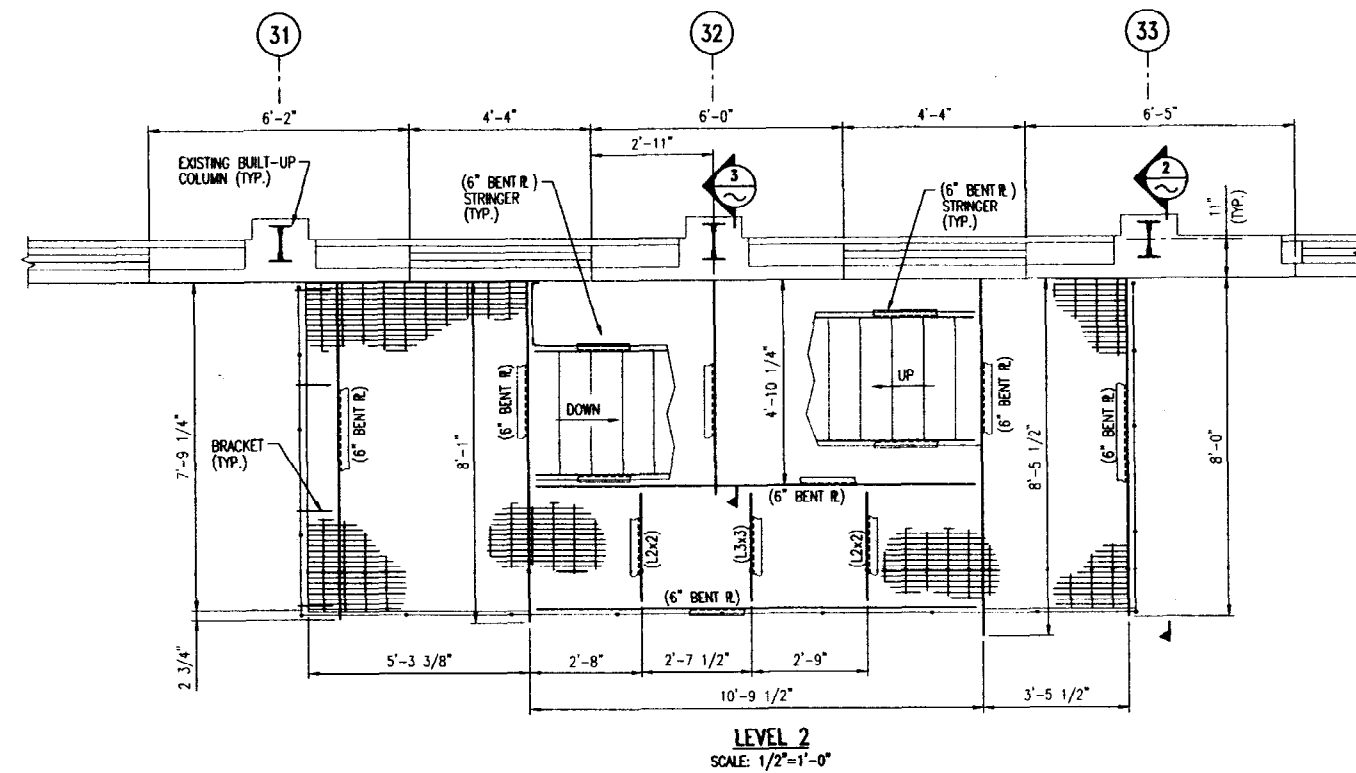
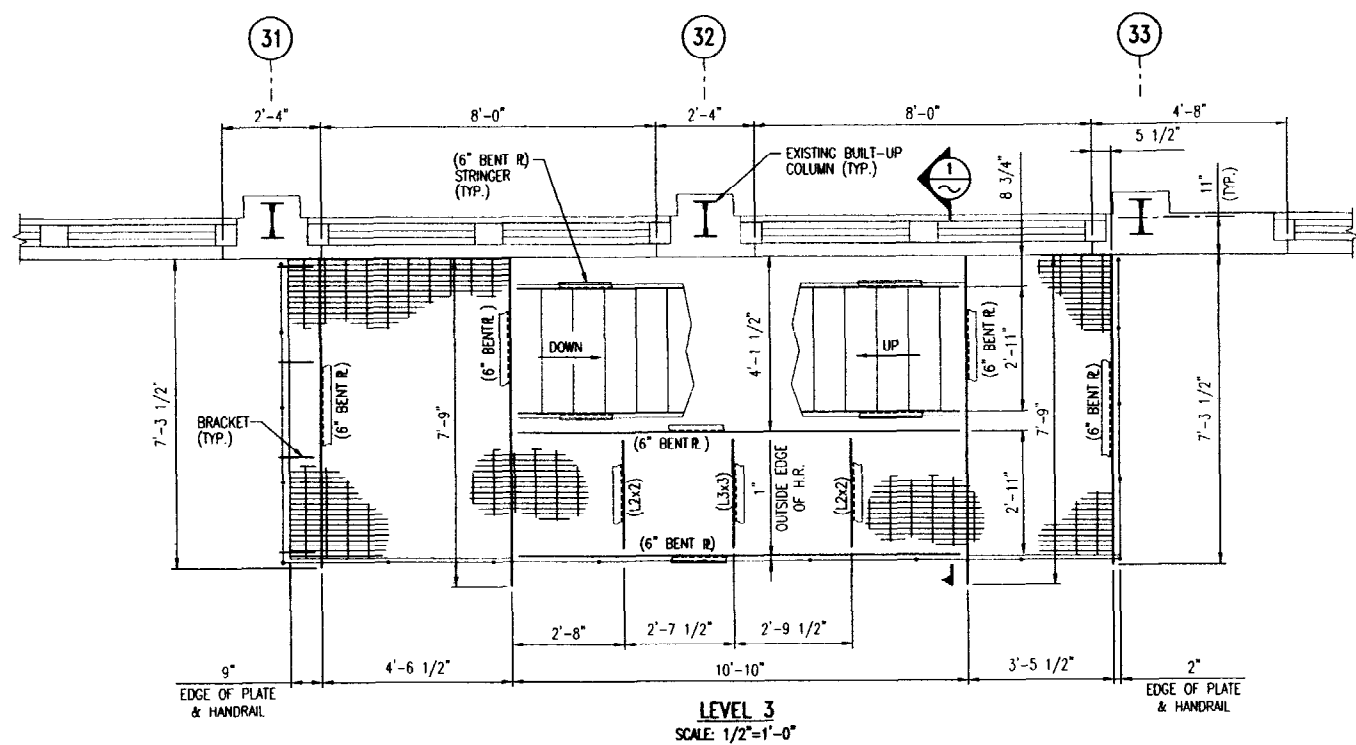

SECTION 1
SCALE: 1"=1'-0"

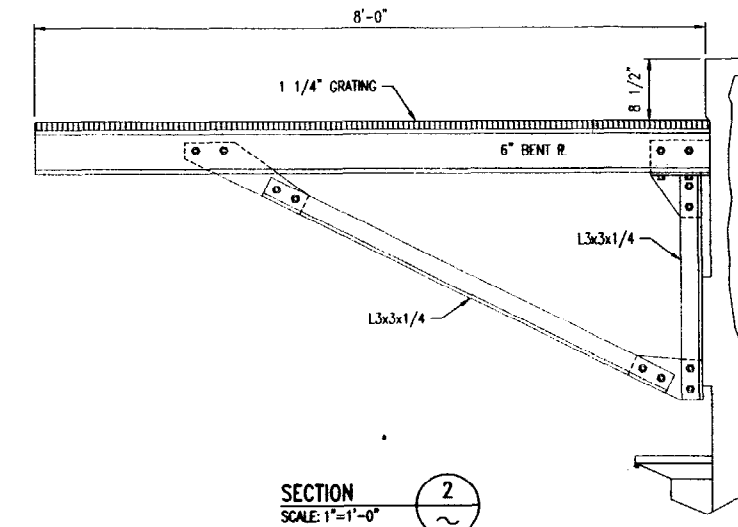

SECTION 2
SCALE: 1"=1'-0"

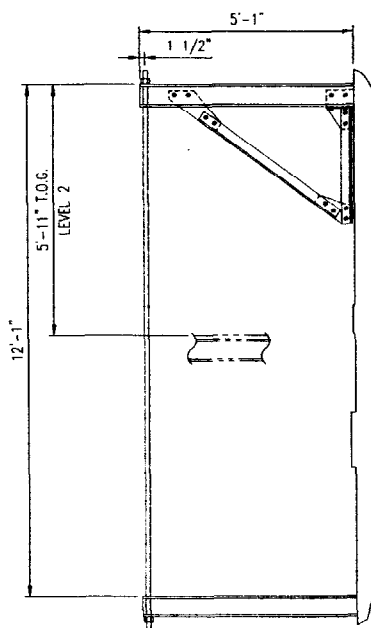

SECTION 3
SCALE: 1/2"=1'-0"

THIS IS AN AUTOCAD FILE. TO PRODUCE A SCALEABLE DRAWING, IT MUST BE PLOTTED AT THE INTENDED SCALE.

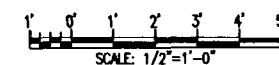

PRELIMINARY - NOT FOR CONSTRUCTION
 APPROVED FOR CONSTRUCTION
 SUPERSEDES ALL PREVIOUS ISSUES
 BY *[Signature]* DATE 11-5-2003

REFERENCE DRAWINGS		
DWG. NO.	TITLE	BY

LEGEND:
 (L3x3) - EXISTING STEEL MEMBER
 F.V. - FIELD VERIFY

Released For Information
 Date: Nov 05, 2003

0	CLIENT	INFORMATION
REV.	ISSUED TO	ISSUED FOR

THIS DRAWING IS THE PROPERTY OF NEILL AND GUNTER INCORPORATED AND IS TO BE USED ONLY FOR THE SPECIFIC PROJECT DESCRIBED ON THE DRAWING. NO REPRODUCTIONS SHALL BE MADE WITHOUT THE EXPRESSED WRITTEN CONSENT OF NEILL AND GUNTER INCORPORATED.

NO.	DATE	BY	REVISIONS		CHKD.
			DESCRIPTION	DATE	

Neill and Gunter

PORTLAND PRESS HERALD
 CONGRESS STREET OFFICE BUILDING

FIRE ESCAPE MAINTENANCE
 FIRE ESCAPE EXISTING CONDITIONS
 LEVELS 2 & 3
 PLANS & SECTIONS

JOB NO. 25216
 DWG. NO. D-3003

PRELIMINARY - NOT FOR CONSTRUCTION
 APPROVED FOR CONSTRUCTION
 SUPERSEDES ALL PREVIOUS ISSUES
 BY *Mill and Gunter* DATE **1-5-2003**

DWG. NO.	TITLE	BY

NOTES:
 1. FOR GENERAL AND STEEL NOTES SEE DRAWING D-3008.

LEGEND:
 (L3x3) - EXISTING STEEL MEMBER
 F.V. - FIELD VERIFY

Released For Construction
 Date: **Nov 05, 2003**

REV.	ISSUED TO	CLIENT	CONSTRUCTION
0			

NO.	DATE	BY	REVISIONS	ISSUED FOR

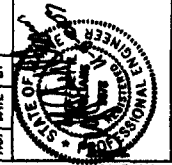

Mill and Gunter
 PORTLAND PRESS HERALD
 CONGRESS STREET OFFICE BUILDING
 FIRE ESCAPE MAINTENANCE
 FIRE ESCAPE NEW BLDG. SUPPORT
 LEVELS 6 & 7
 PLANS & SECTIONS
 DWG. NO. 25216
 PROJ. NO. D-3004

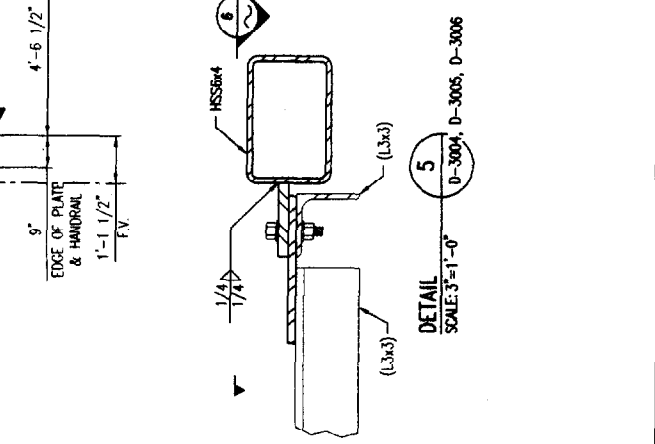
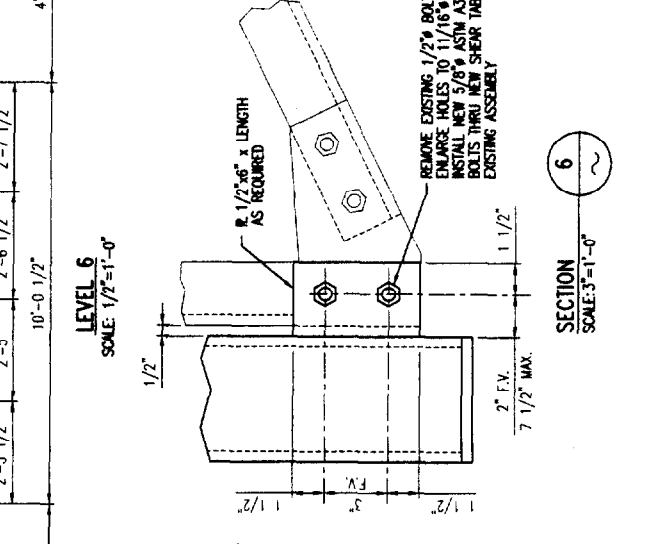
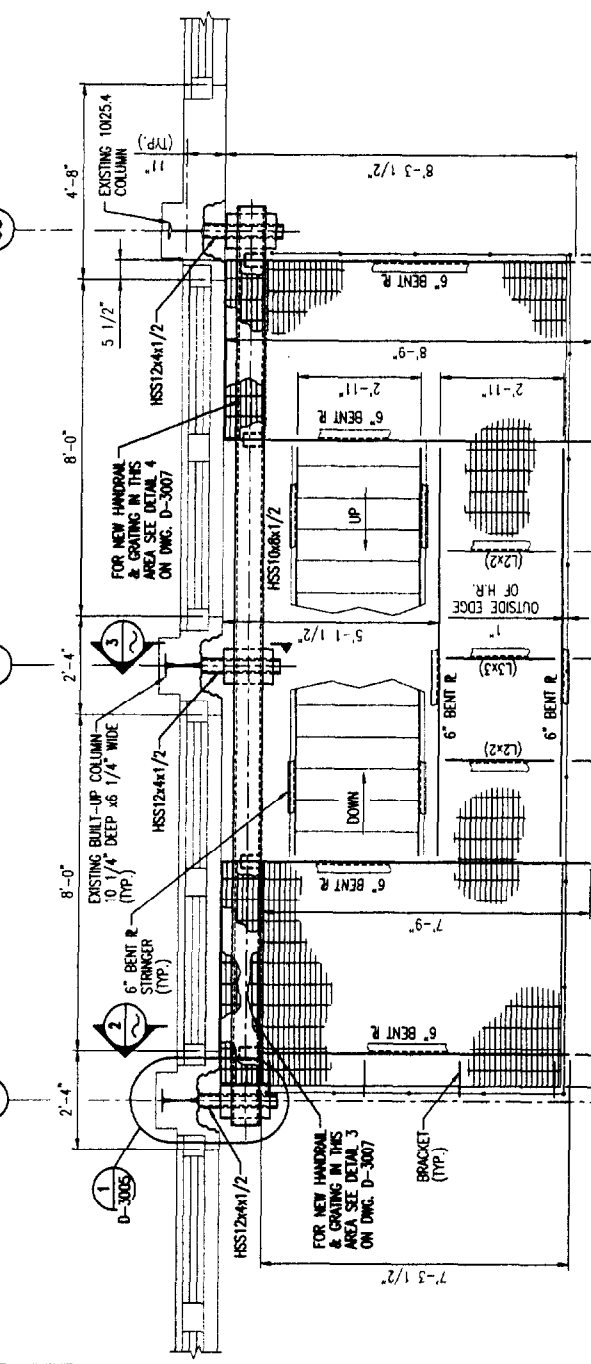
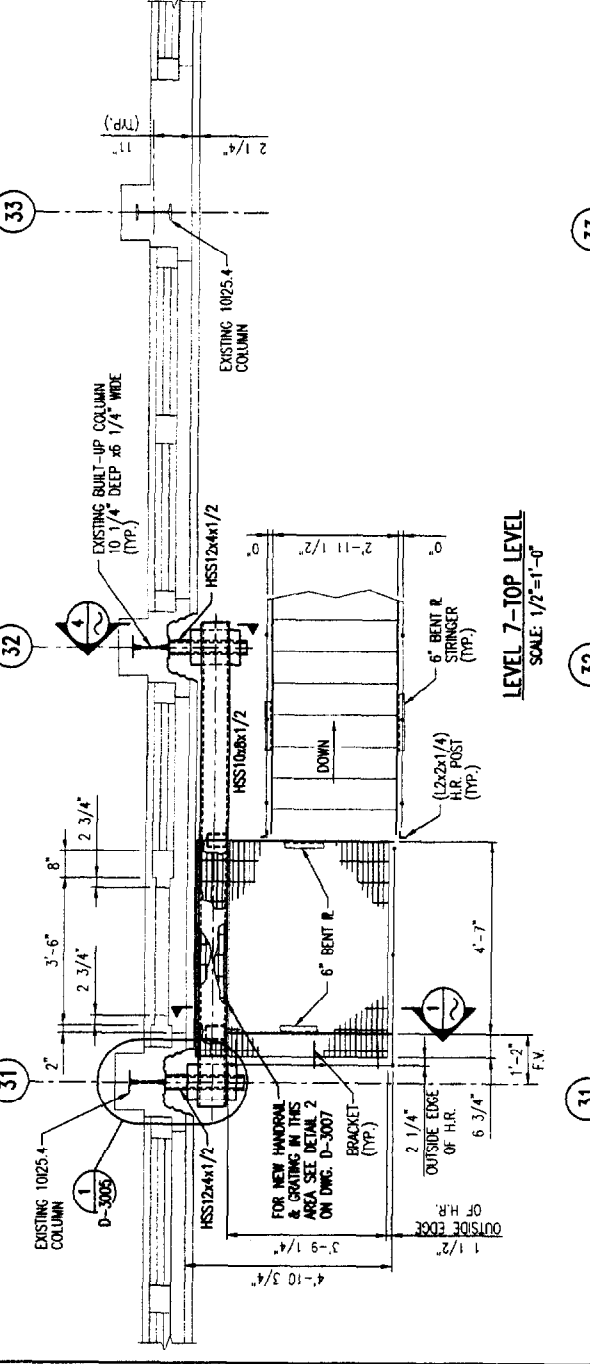
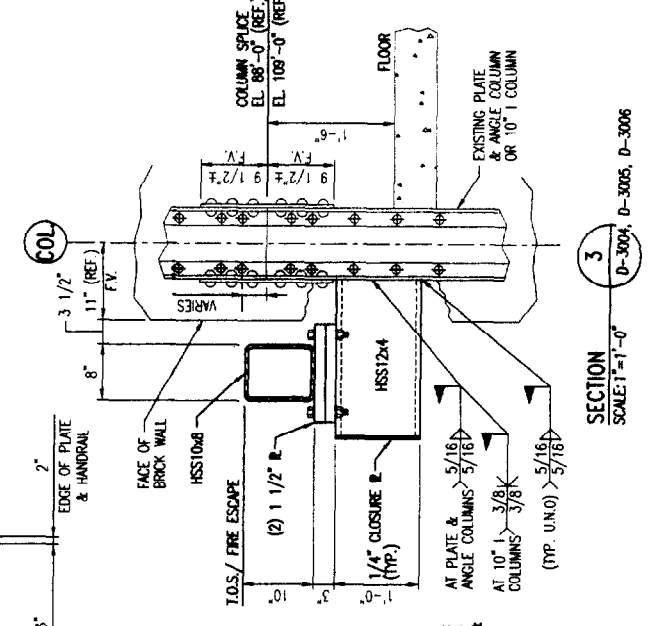
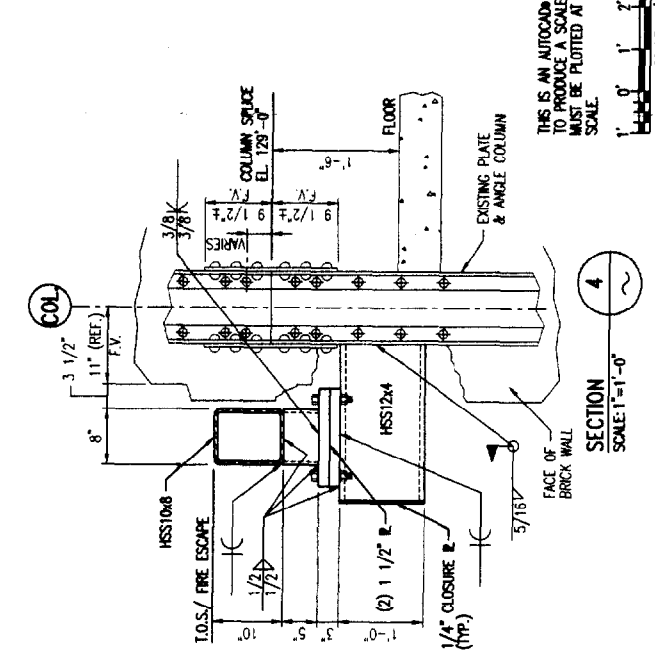
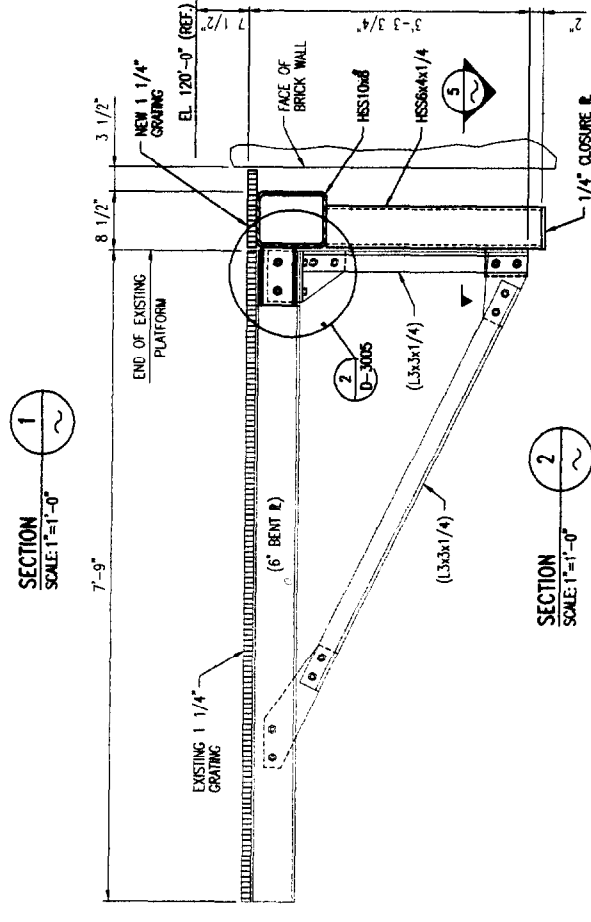
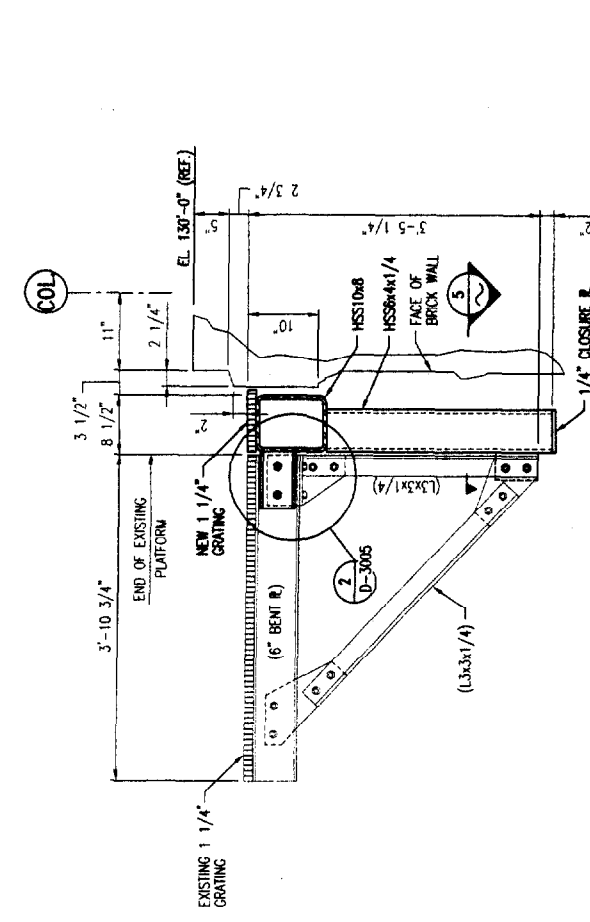

THIS IS AN AUTOCAD FILE
 TO PRODUCE A SCALEABLE DRAWING, IT
 MUST BE PLOTTED AT THE INTENDED
 SCALE.
 SCALE: 1/2"=1'-0"

SECTION 3
 SCALE: 1/2"=1'-0"
 D-3004, D-3005, D-3006

SECTION 6
 SCALE: 3/4"=1'-0"
 D-3004, D-3005, D-3006

NO. 25216 D-3005

PLANS & SECTIONS
LEVELS 4 & 5
FIRE ESCAPE NEW BLDG. SUPPORT
FIRE ESCAPE MAINTENANCE

PORTLAND PRESS HERALD
CONGRESS STREET OFFICE BUILDING

Abell and Granger

Professional Engineer Seal: **STATE OF OREGON**, **ABELL AND GRANGER ENGINEERS**, **PORTLAND, OREGON**. License No. 12345.

NO.	DATE	BY	REVISIONS

REV.	ISSUED FOR
0	CLIENT
	CONSTRUCTION

THIS DRAWING IS THE PROPERTY OF ABELL AND GRANGER ENGINEERS. IT SHALL BE KEPT IN THE OFFICE OF ABELL AND GRANGER ENGINEERS AND NOT BE LOANED, REPRODUCED, COPIED, OR IN ANY MANNER DISSEMINATED WITHOUT THE WRITTEN PERMISSION OF ABELL AND GRANGER ENGINEERS.

Released For Construction
Date: *Jan 28, 2008*

NOTES:
1. FOR GENERAL AND STEEL NOTES SEE DRAWING D-3008.
LEGEND:
(L3X3) - EXISTING STEEL MEMBER
F.Y. - FIELD VERIFY

DATE	BY	DESCRIPTION
<i>1-5-2008</i>	<i>[Signature]</i>	APPROVED FOR CONSTRUCTION
		SUPERSEDES ALL PREVIOUS ISSUES
		PRELIMINARY - NOT FOR CONSTRUCTION

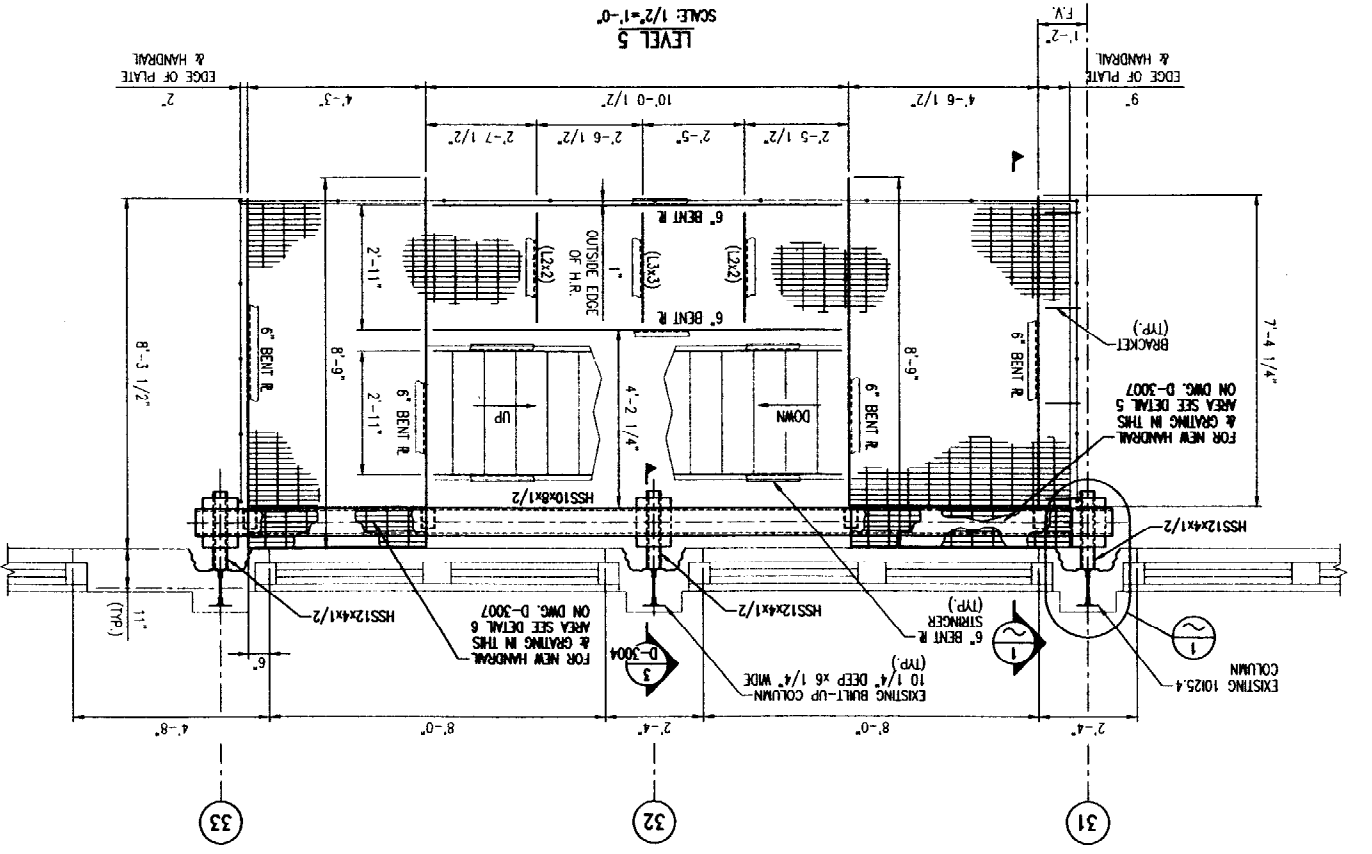
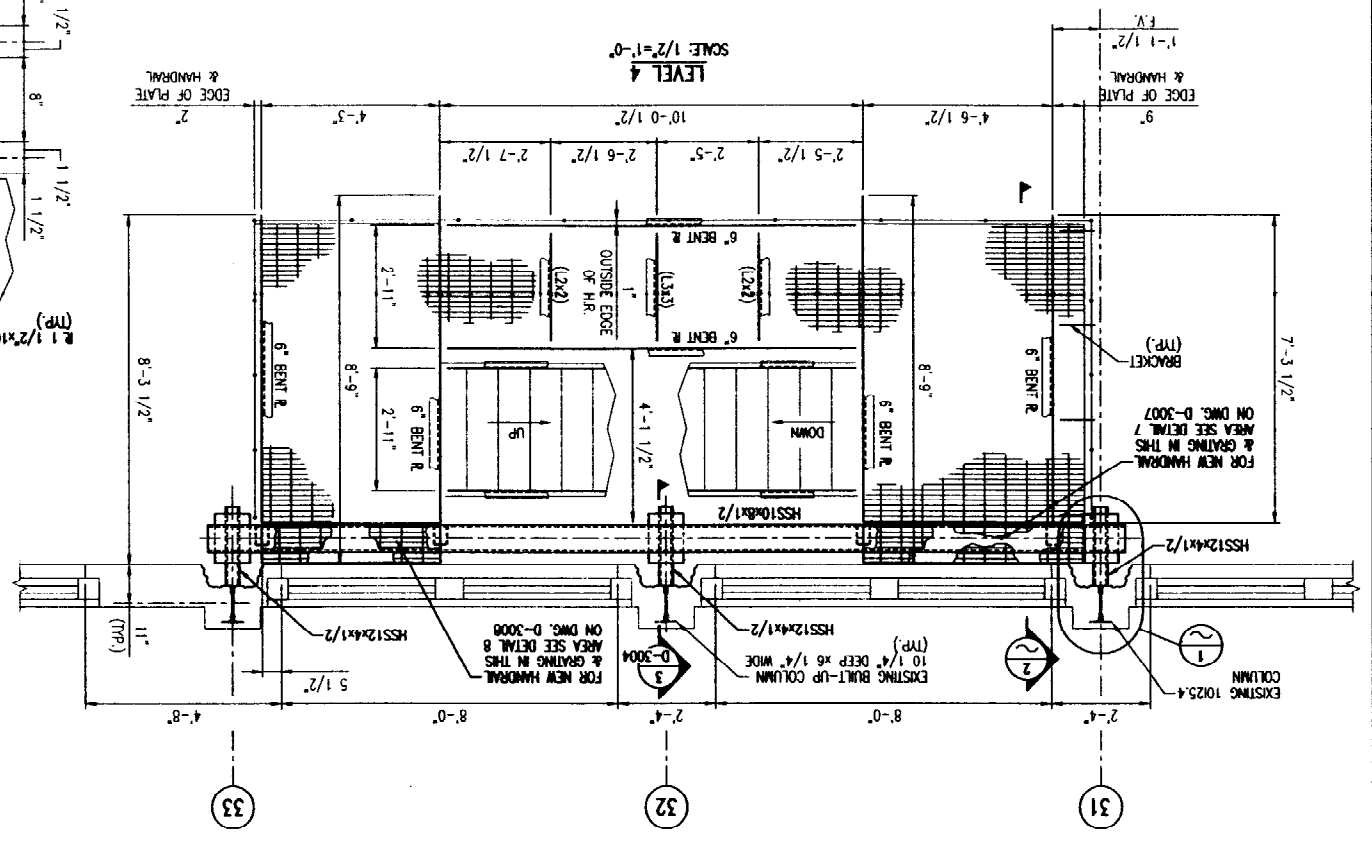
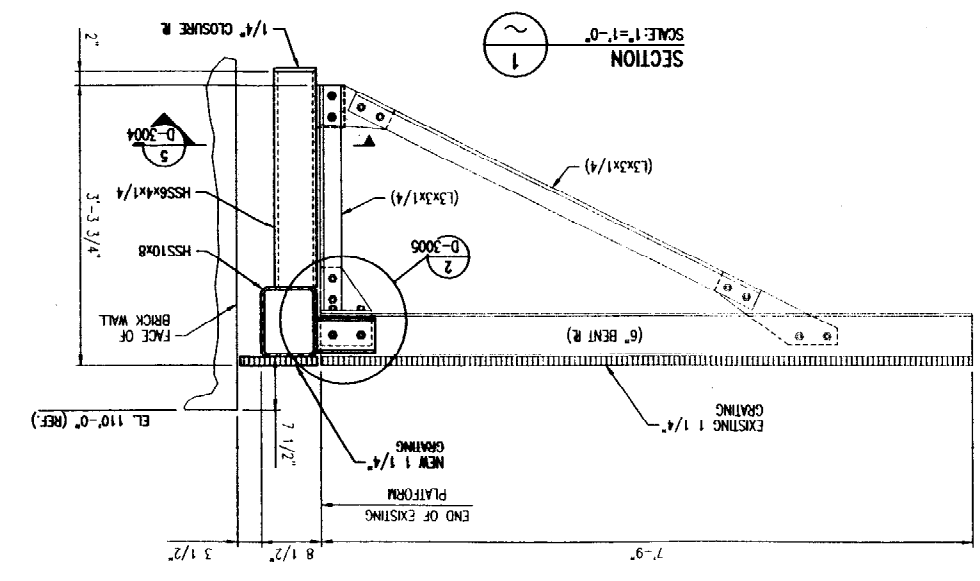
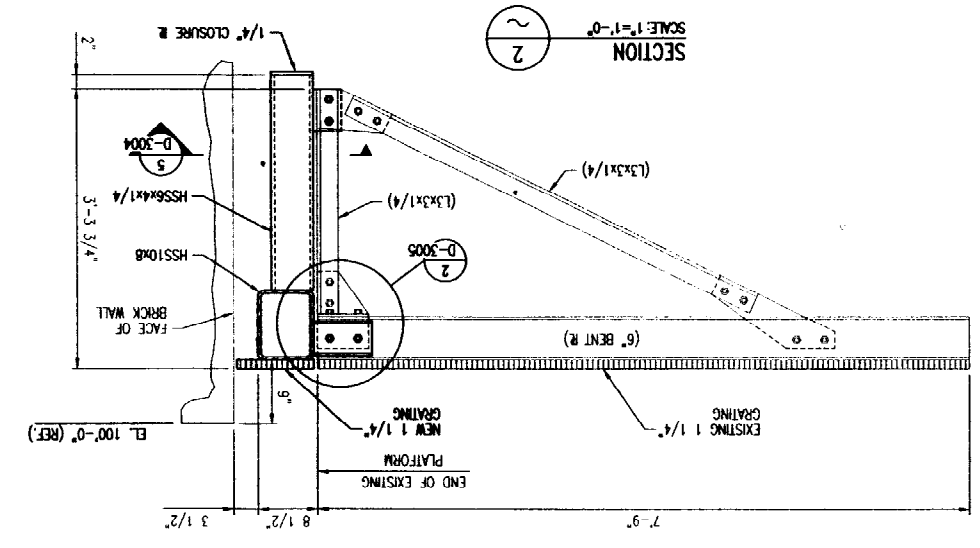
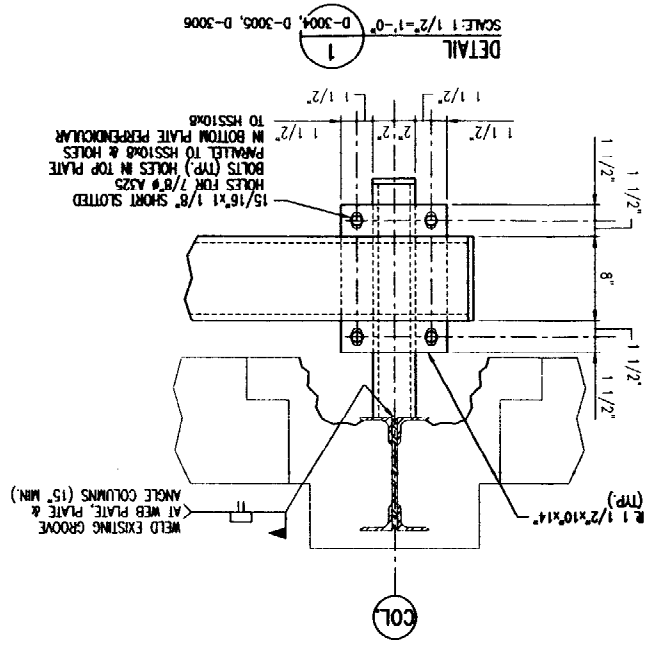
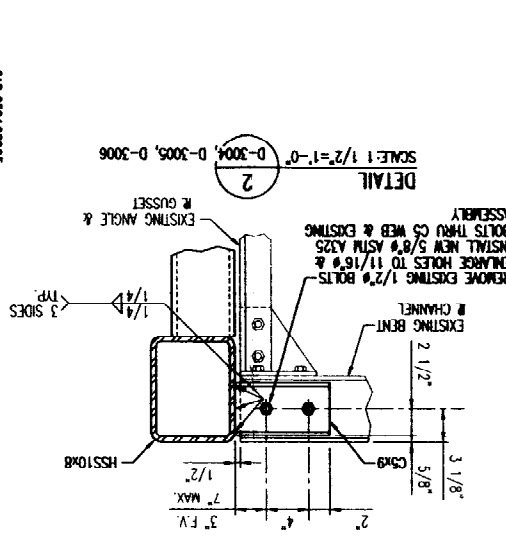
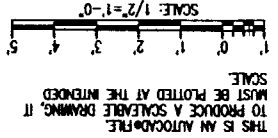

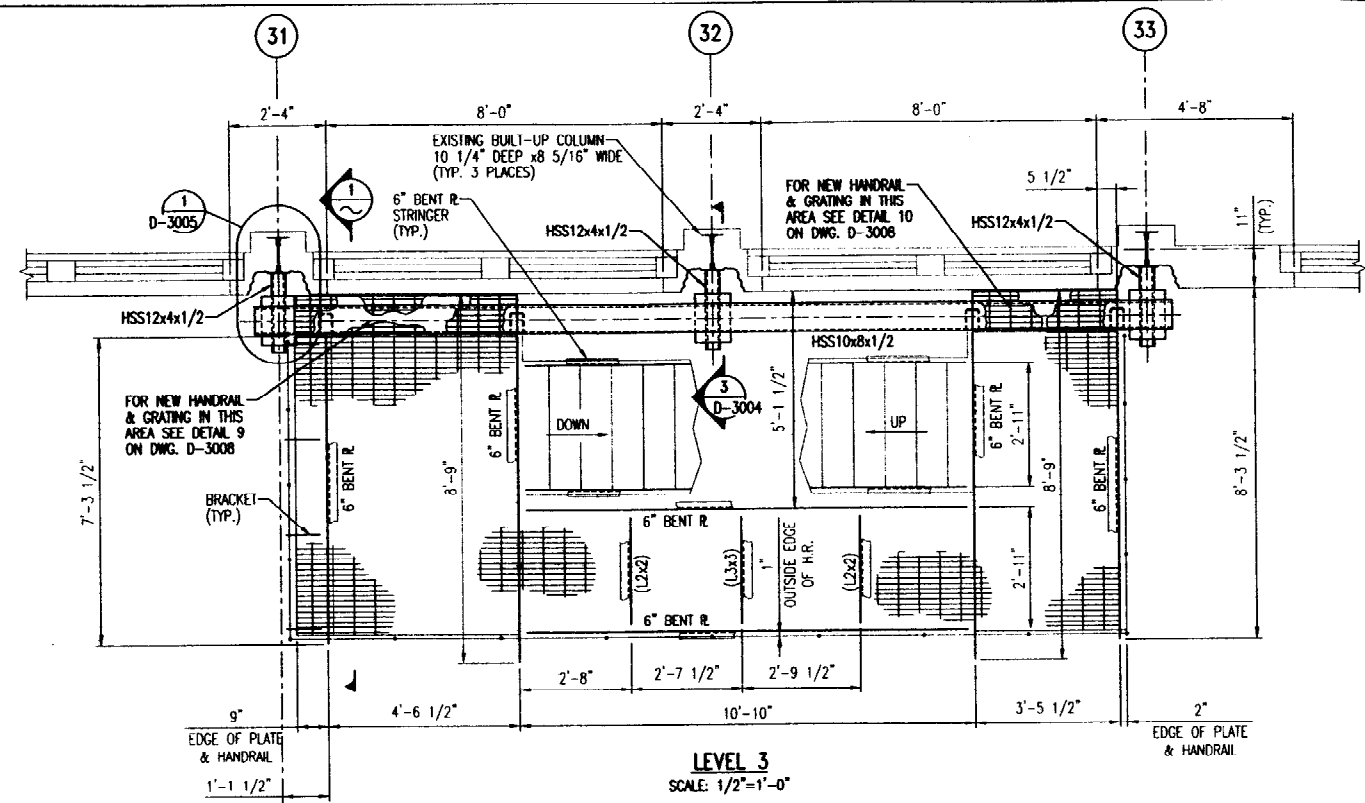

LEVEL 3
SCALE: 1/2"=1'-0"

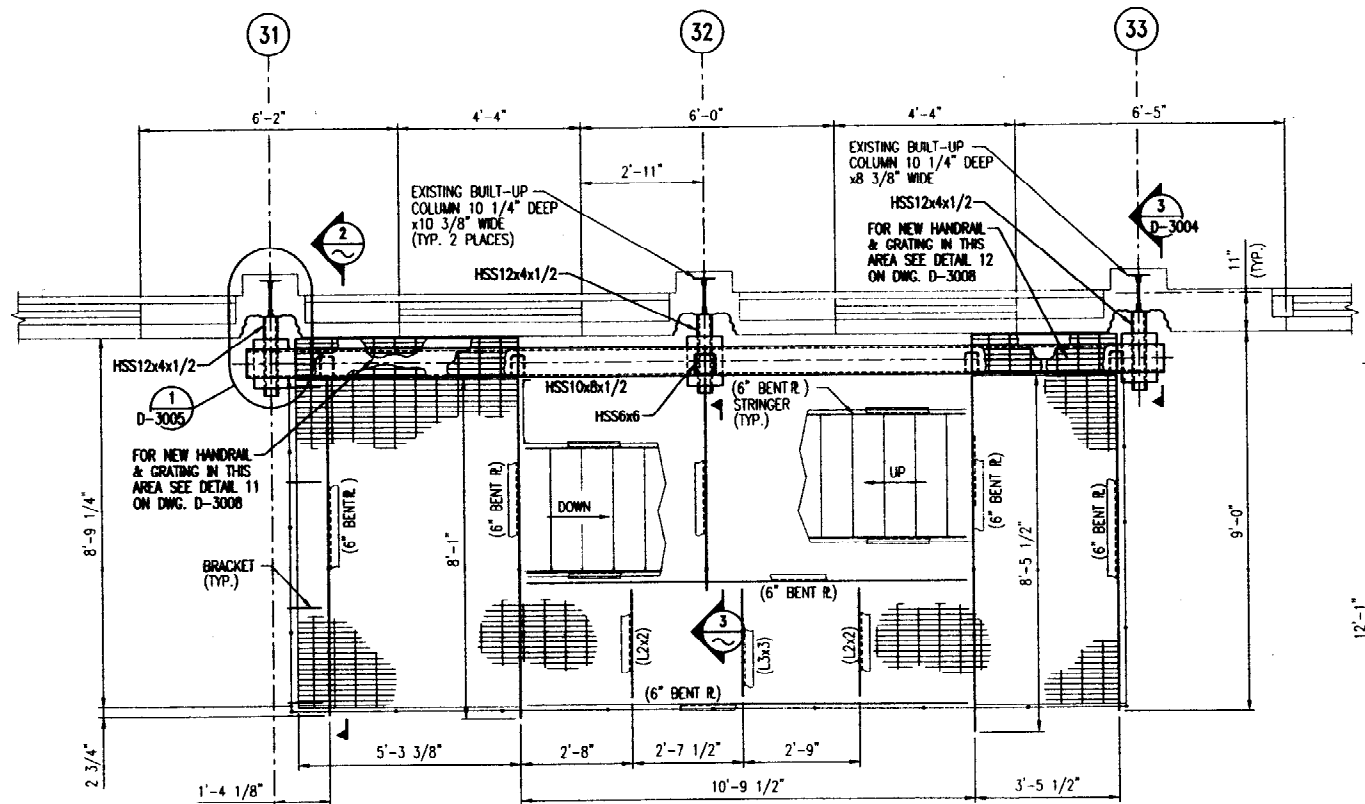

LEVEL 2
SCALE: 1/2"=1'-0"

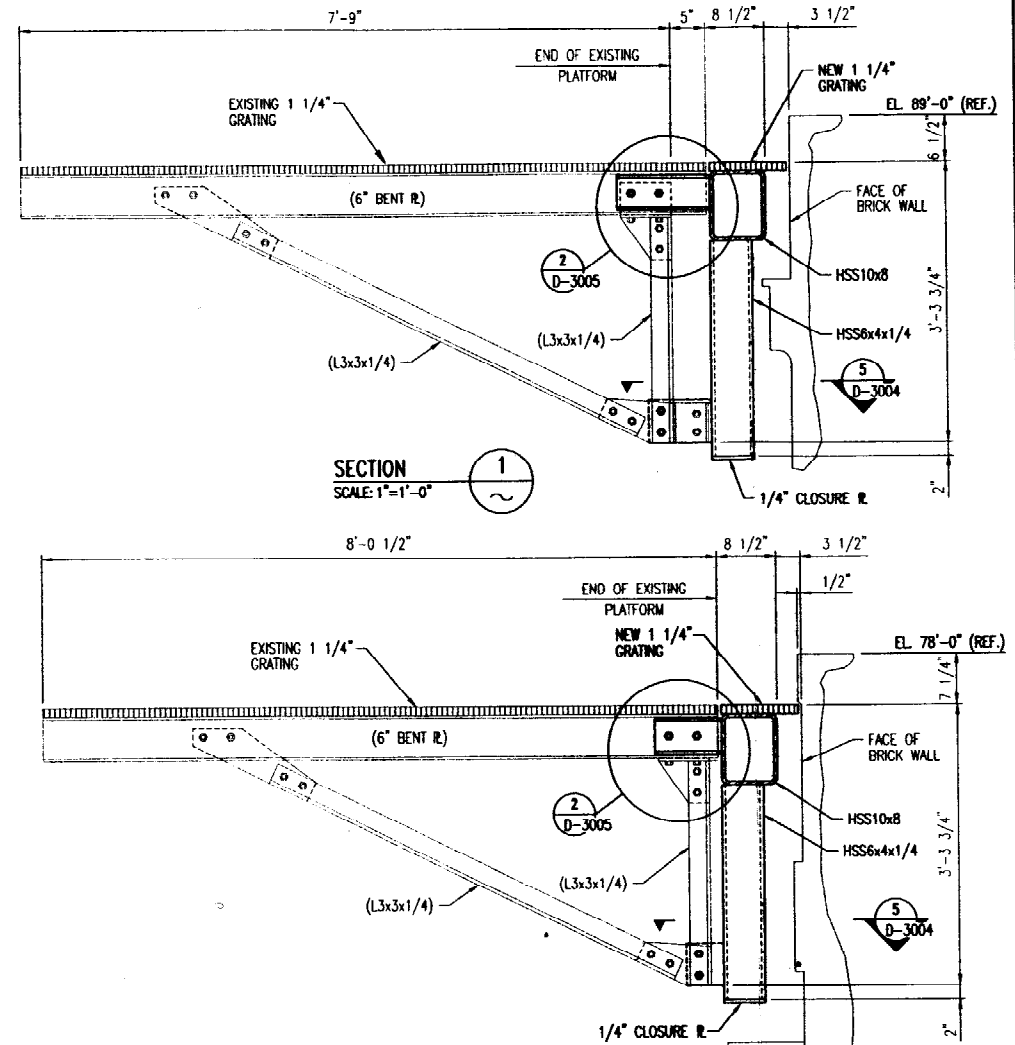

SECTION 1
SCALE: 1"=1'-0"

SECTION 2
SCALE: 1"=1'-0"

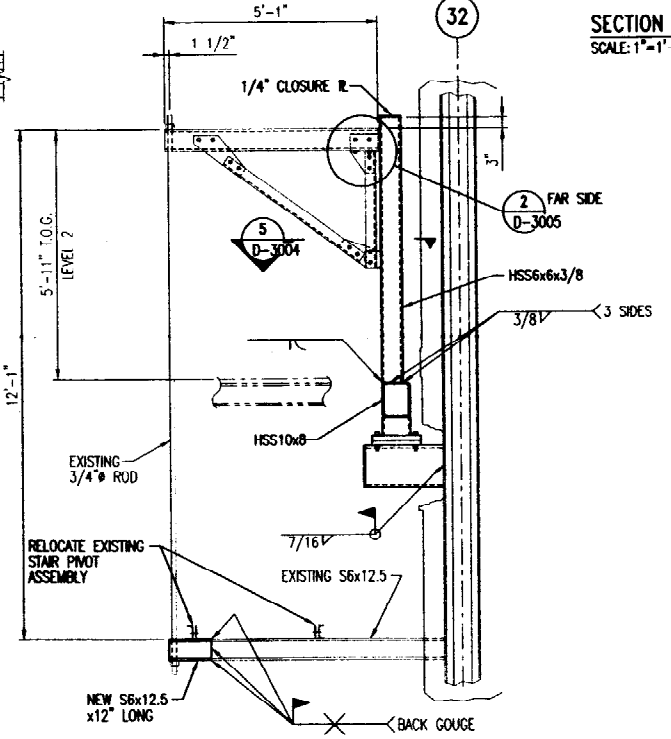

SECTION 3
SCALE: 1/2"=1'-0"

PRELIMINARY - NOT FOR CONSTRUCTION
 APPROVED FOR CONSTRUCTION
 SUPERSEDES ALL PREVIOUS ISSUES
 BY *[Signature]* DATE 11-5-2003

REFERENCE DRAWINGS		
DWG. NO.	TITLE	BY

NOTES:
 1. FOR GENERAL AND STEEL NOTES SEE DRAWING D-3008.
LEGEND:
 (L3x3) - EXISTING STEEL MEMBER
 F.V. - FIELD VERIFY

Released For Construction
Date: Nov 05, 2003

0	CLIENT	CONSTRUCTION
REV.	ISSUED TO	ISSUED FOR

THIS DRAWING IS THE PROPERTY OF NEILL AND GUNTER INCORPORATED AND IS TO BE USED ONLY FOR THE SPECIFIC PROJECT IDENTIFIED ON THE DRAWING. NO REUSE SHALL BE MADE WITHOUT THE EXPRESSED WRITTEN CONSENT OF NEILL AND GUNTER INCORPORATED.

NO.	DATE	BY	REVISIONS	CHKD.

Neill and Gunter

PORTLAND PRESS HERALD
CONGRESS STREET OFFICE BUILDING

FIRE ESCAPE MAINTENANCE
FIRE ESCAPE NEW BLDG. SUPPORT
LEVELS 2 & 3
PLANS & SECTIONS

JOB NO. 25216 DWG. NO. D-3006

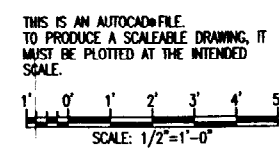

THIS IS AN AUTOCAD FILE.
TO PRODUCE A SCALEABLE DRAWING, IT
MUST BE PLOTTED AT THE INTENDED
SCALE.