

CAP A VIEW 3  
3/8" = 1'

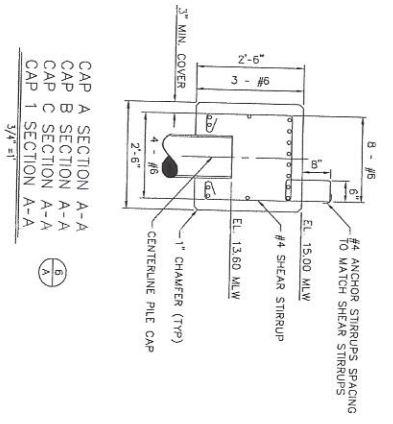

CAP A SECTION A-A  
CAP B SECTION A-A  
CAP C SECTION A-A  
CAP 1 SECTION A-A  
3/4" = 1'

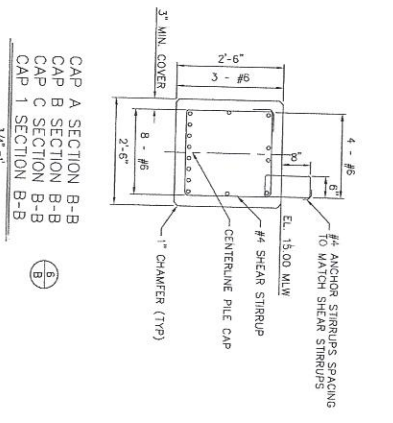

CAP A SECTION B-B  
CAP B SECTION B-B  
CAP C SECTION B-B  
CAP 1 SECTION B-B  
3/4" = 1'

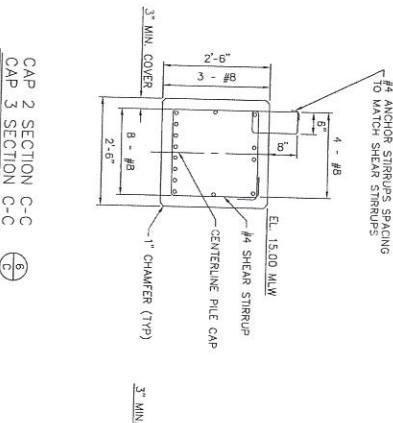

CAP 2 SECTION C-C  
CAP 3 SECTION C-C  
3/4" = 1'

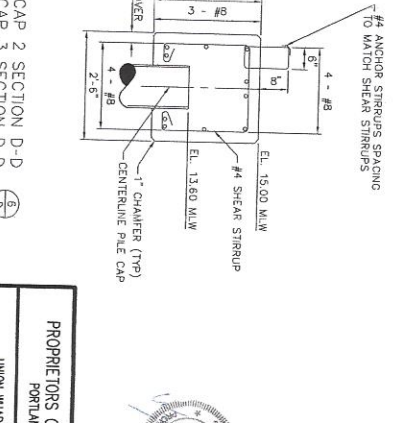

CAP 2 SECTION D-D  
CAP 3 SECTION D-D  
3/4" = 1'



PROPRIETORS OF UNION WHARF  
PORTLAND, MAINE

UNION WHARF PER REPAIR  
CAP A VIEW 3 AND DETAILS

**TEC ASSOCIATES**  
CONSULTING ENGINEERS  
125 BROAD ST. PORTLAND, ME 04101  
TEL: 603.761.1111 FAX: 603.761.1112

SCALE: NOTED  
DATE: 1/13/2017  
DRAWN BY: [Signature]  
CHECKED BY: [Signature]  
IN CHARGE: [Signature]