

GENERAL NOTES

NOTES ON THESE DRAWINGS ARE NOT INTENDED TO REPLACE SPECIFICATIONS. SEE SPECIFICATIONS FOR REQUIREMENTS IN ADDITION TO DRAWING NOTES.

STRUCTURAL DRAWINGS SHALL BE USED IN CONJUNCTION WITH PROJECT SPECIFICATIONS AND THE ARCHITECTURAL, MECHANICAL, ELECTRICAL, PLUMBING, FIRE PROTECTION, EQUIPMENT, SITE AND SHOP DRAWINGS. CONSULT THESE DRAWINGS FOR LOCATIONS AND DIMENSIONS OF CHASES, INSERTS, SLEEVES, DEPRESSIONS AND OTHER DETAILS NOT SHOWN ON THE STRUCTURAL DRAWINGS.

ALL DIMENSIONS, ELEVATIONS AND CONDITIONS MUST BE VERIFIED IN THE FIELD BY THE GENERAL CONTRACTOR. ANY DISCREPANCY SHALL BE BROUGHT TO THE ATTENTION OF THE ENGINEER BEFORE PROCEEDING WITH THE AFFECTED PART OF THE WORK. THE CONTRACTOR SHALL DETERMINE ALL NECESSARY DIMENSIONS, ELEVATIONS AND CONDITIONS REQUIRED FOR THE FABRICATION AND ERECTION OF THE BUILDING'S COMPONENTS PRIOR TO THE SUBMISSION OF SHOP DRAWINGS. ALL SHOP DRAWINGS SHALL ACCURATELY REFLECT THE GENERAL CONTRACTOR'S VERIFICATION OF FIELD CONDITIONS.

SHOP DRAWINGS SHALL BE ORIGINAL DRAWINGS PREPARED BY THE GENERAL CONTRACTOR OR A SUBCONTRACTOR. REPRODUCTION OF ANY STRUCTURAL DRAWING FOR USE AS A SHOP DRAWING IS NOT ACCEPTABLE.

THE STRUCTURE IS DESIGNED TO BE SELF-SUPPORTING AND STABLE AFTER THE BUILDING IS COMPLETE. IT IS SOLELY THE GENERAL CONTRACTOR'S RESPONSIBILITY TO DETERMINE ERECTION PROCEDURES AND SEQUENCING TO ENSURE THE SAFETY OF THE BUILDING AND ITS COMPONENTS DURING ERECTION. THIS INCLUDES THE ADDITION OF NECESSARY SHORING, SHEETING, TEMPORARY BRACING, GUY'S AND/OR TIEDOWNS. SUCH MATERIAL SHALL REMAIN THE PROPERTY OF THE GENERAL CONTRACTOR AFTER COMPLETION OF THE BUILDING.

SECTIONS AND DETAILS SHOWN ON THE STRUCTURAL DRAWINGS SHALL BE CONSIDERED TYPICAL AND USED IN SIMILAR CONDITIONS.

THE GENERAL CONTRACTOR AND ALL SUBCONTRACTORS SHALL FOLLOW ALL APPLICABLE FEDERAL, STATE AND MUNICIPAL REGULATIONS INCLUDING THE FEDERAL DEPARTMENT OF LABOR OCCUPATIONAL SAFETY AND HEALTH ACT.

DESIGN CRITERIA

BUILDING CODE: 2009 INTERNATIONAL BUILDING CODE

DESIGN LOADS:

LIVE LOADS

UPPER FLOORS OFFICE AREAS AND CORRIDORS	80 PSF
STAIRS AND EXITS	100 PSF
FIRST FLOOR LOBBIES	100 PSF

SNOW LOAD

GROUND SNOW LOAD, P_g	60 PSF
SNOW EXPOSURE FACTOR, C_e	1.0
SNOW LOAD IMPORTANCE FACTOR, I_s	1.0
THERMAL FACTOR, C_t	1.0
FLAT ROOF SNOW LOAD, P_f	42 PSF

WIND LOAD

BASIC WIND SPEED (3 SEC 60ST), V_b	100 MPH
WIND IMPORTANCE FACTOR, I_w	1.0
BUILDING CATEGORY	I
EXPOSURE CATEGORY	B

EARTHQUAKE DESIGN DATA

SEISMIC IMPORTANCE FACTOR, I_e	1.0
MAPPED SPECTRAL RESPONSE ACCELERATIONS	
0.2 SEC PERIOD, S_s	0.240
1 SEC PERIOD, S_1	0.078

SITE CLASS

SPECTRAL RESPONSE COEFFICIENTS	E
0.2 PERIOD 5% DAMPED, S_{ds}	0.401
1 SEC PERIOD 5% DAMPED, S_{d1}	0.182
SEISMIC DESIGN CATEGORY	C
BASIC SEISMIC-FORCE-RESISTING SYSTEM	ORDINARY STEEL CONCENTRICALLY BRACED FRAME

DESIGN BASE SHEAR

SEISMIC RESPONSE COEFFICIENT, C_s	0.123
DEFLECTION AMPLIFICATION FACTOR, C_d	3.25
RESPONSE MODIFICATION COEFFICIENT, R	3.25
SYSTEM OVERSTRENGTH FACTOR, Ω	2.0
ANALYSIS PROCEDURE	EQUIVALENT LATERAL FORCE

COLUMN SCHEDULE				
COLUMN MARK	SIZE	BOT. OF BASE PL ELEV.	BASE PL TYPE	TOP OF COLUMN ELEV.
A-1 A-2 A-3 A-4 B-1 B-4 C-3 C-4	W10x33	8'-11"	A	59'-8 1/2"
B-2 B-3	W10x33	8'-11"	A	59'-2 1/2"
C-1 C-2 D-1 D-4	W10x33	8'-5"	A	59'-8 1/2"
D-2 D-3	W10x33	8'-5"	A	59'-2 1/2"
E-1 E-2 E-3 E-4	W10x33	7'-11"	A	59'-8 1/2"

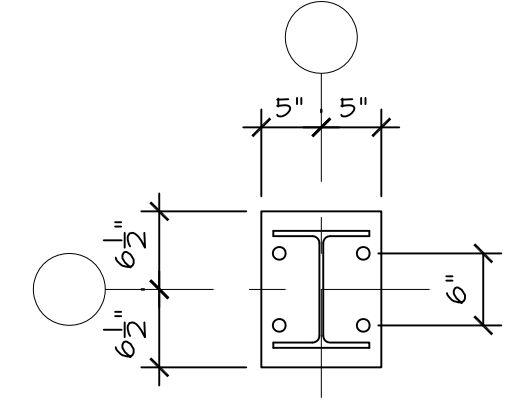

TYPE A BASE PLATE DETAIL
3/4"=1'-0"

THICKNESS = 1"
HOLE DIA = 1 1/16"
HOLE EDGE DIST = 1 1/2" U.N.O.

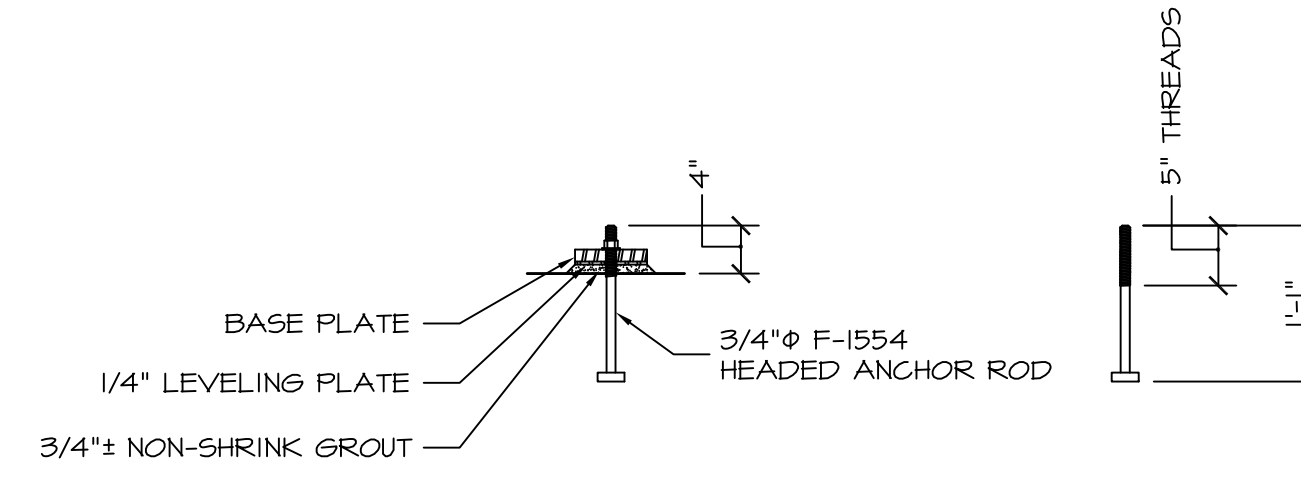

TYPICAL ANCHOR ROD DETAILS
3/4"=1'-0"

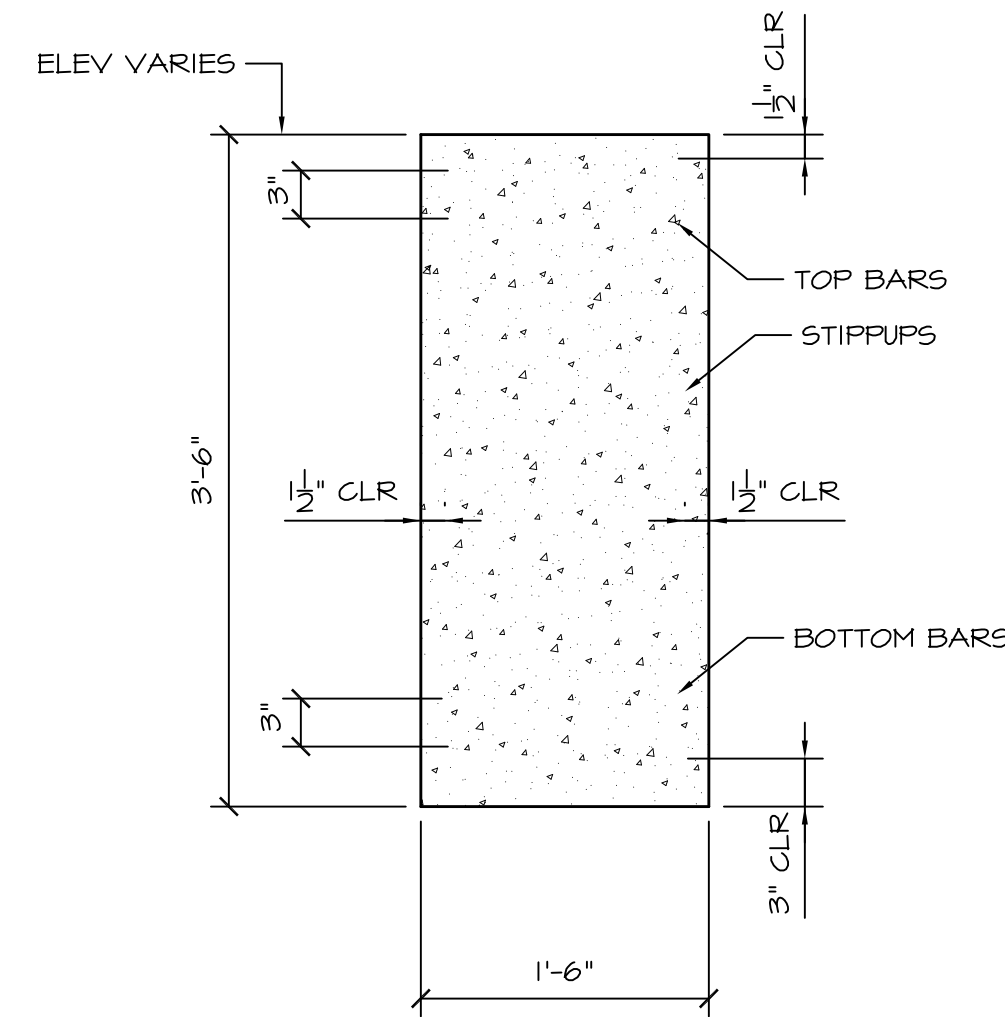

GRADE BEAM AND TIE BEAM REINFORCING SCHEDULE			
MARK	TOP BARS	BOTTOM BARS	STIRRUPS
T.B.	1 ROW (3) #6 EXTEND 24" INTO PILE CAP	1 ROW (3) #6 EXTEND 24" INTO PILE CAP	#3@12"
G.B. 1	2 ROW (3) #8 EXTEND 24" INTO PILE CAP WITH 90° HOOK	2 ROW (3) #7 EXTEND 24" INTO PILE CAP WITH 90° HOOK	#3@9"
G.B. 2	2 ROW (3) #6 EXTEND 15" INTO G.B. 1 WITH 90° HOOK	2 ROW (3) #6 EXTEND 15" INTO G.B. 1 WITH 90° HOOK	#3@9"

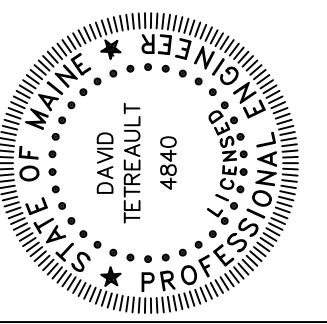

Prepared For:
**PROPRIETORS
OF UNION WHARF**
36 Union Wharf
Portland, Maine 04101

Consulting Engineer:
**STRUCTURAL
DESIGN
CONSULTING**
2696 Lake Shore Road
Unit 130
Glen 03049
Tel 603.293.8038

Architect:
**ARCHETYPE
a r c h i t e c t s**
48 Union Wharf Portland, Maine 04101
(207) 772-6022 Fax (207) 772-4056

Project:
**WIDGERY WHARF
BUILDING 1**
19 Union Wharf
Portland, Maine

Revisions:	02/13/17
Issued for Construction	

Date: 13 Feb 2017
Scale: As Noted
**GENERAL NOTES
AND SCHEDULES**

S0.01