

Proprietors of  
**Union Wharf**  
Address  
City, State

Prepared For:

Consultant:

Architect:  
**ARCHETYPE**  
architects  
48 Union Wharf Portland, Maine 04101  
(207) 772-6022 ARCHETYPE@ARCHETYPEPA.COM

Project:  
**WIDGERY WHARF**  
Widgerly Wharf  
Portland, ME

Revisions:

Scale: As indicated  
**ELEVATOR & STAIR**  
DETAILS

Date: 17 FEB. 2017

**A3.12**

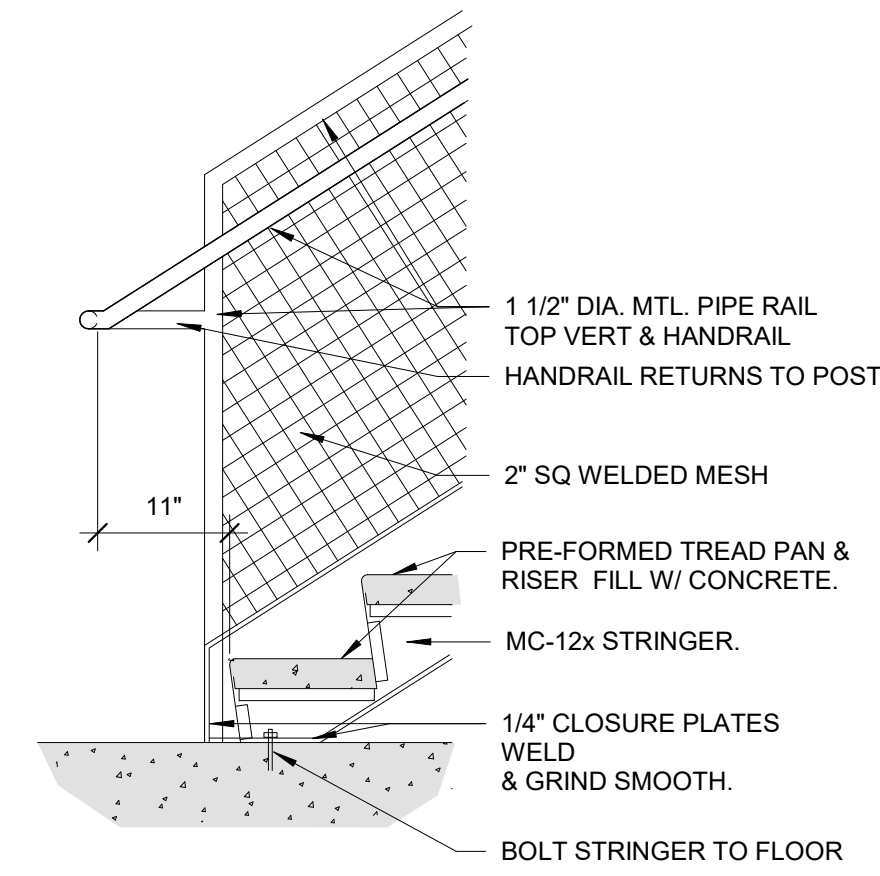

**9** STAIR DETAIL - B/O RUN TO DECK  
3/4" = 1'-0"

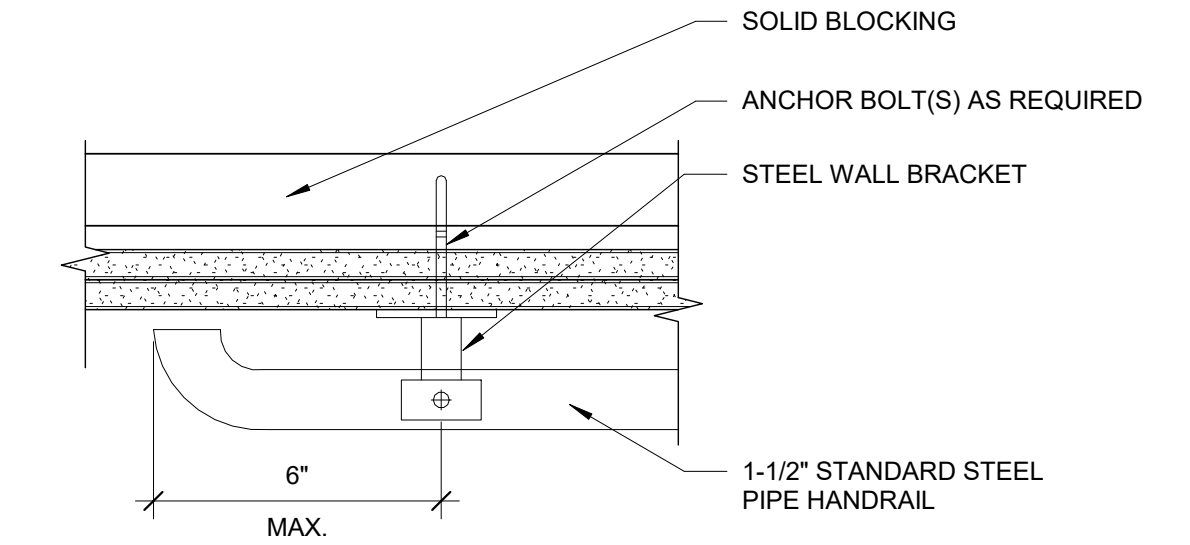

**4** STAIR - METAL HANDRAIL DETAIL - PLAN  
3" = 1'-0"

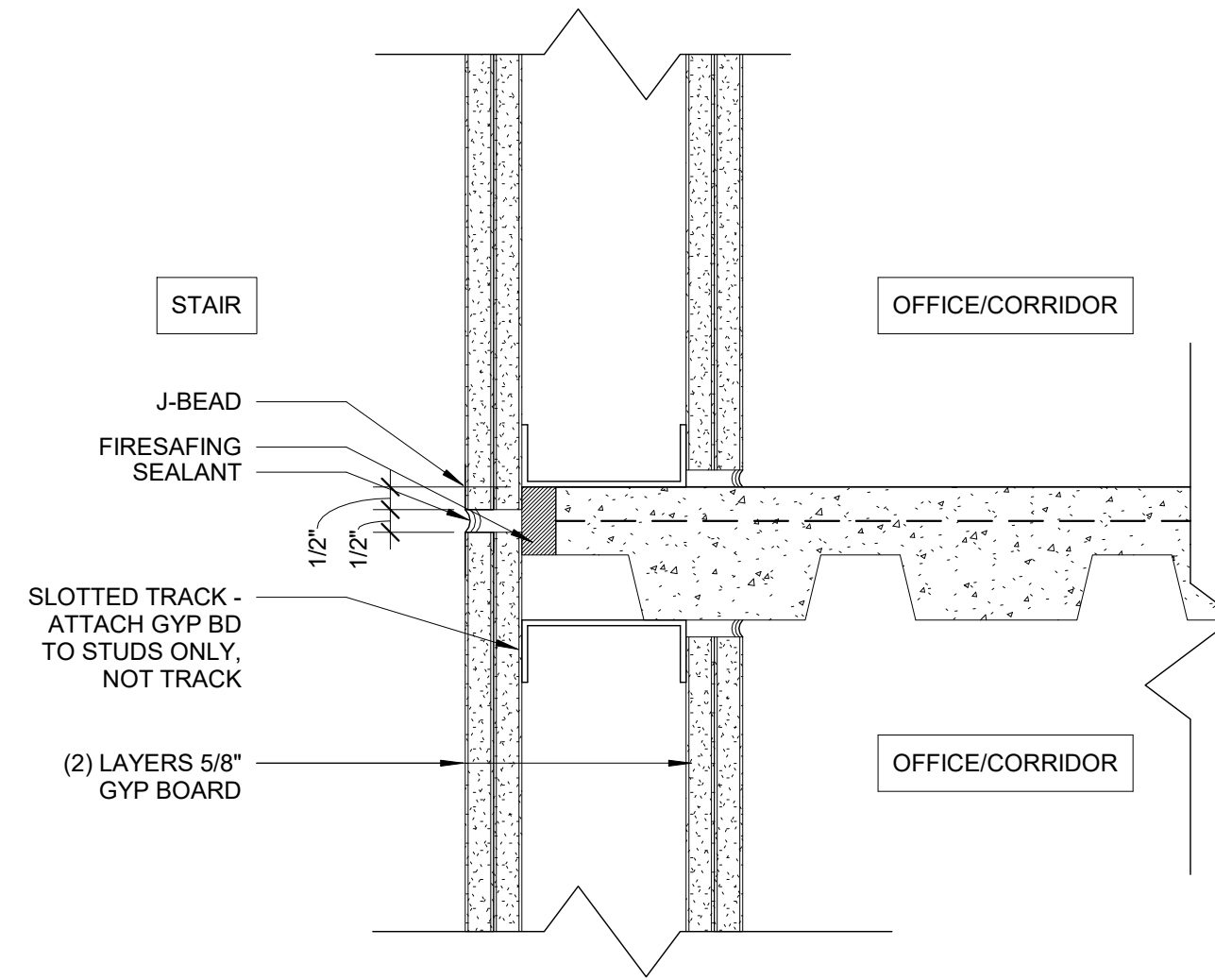

**12** EDGE OF SLAB AT STAIR DETAIL  
3" = 1'-0"

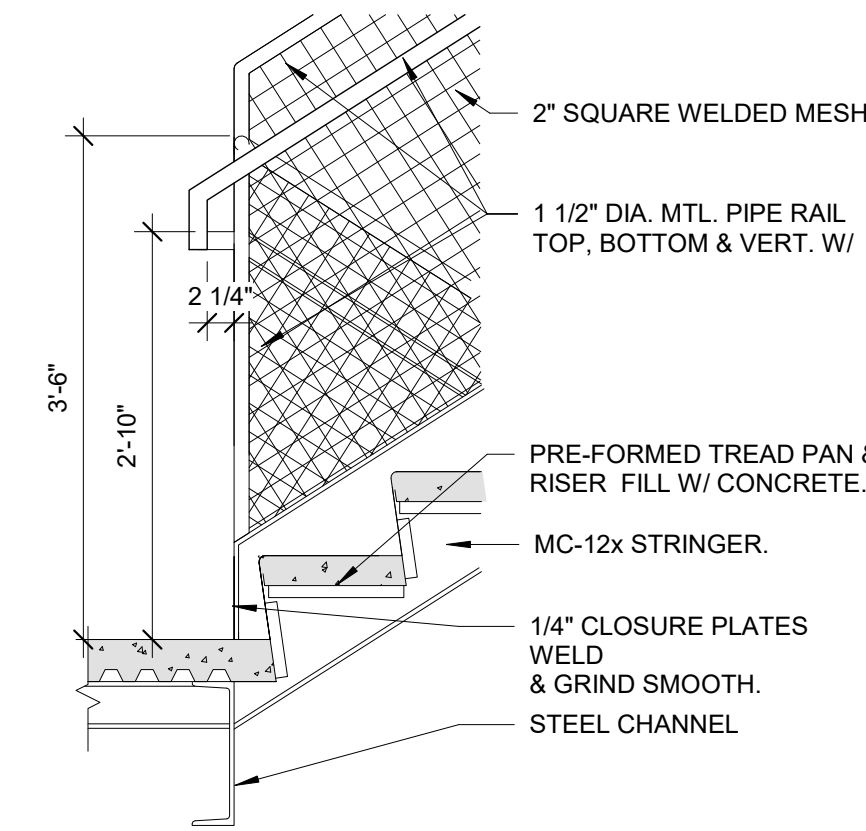

**8** STAIR DETAIL - B/O RUN TO LANDING  
3/4" = 1'-0"

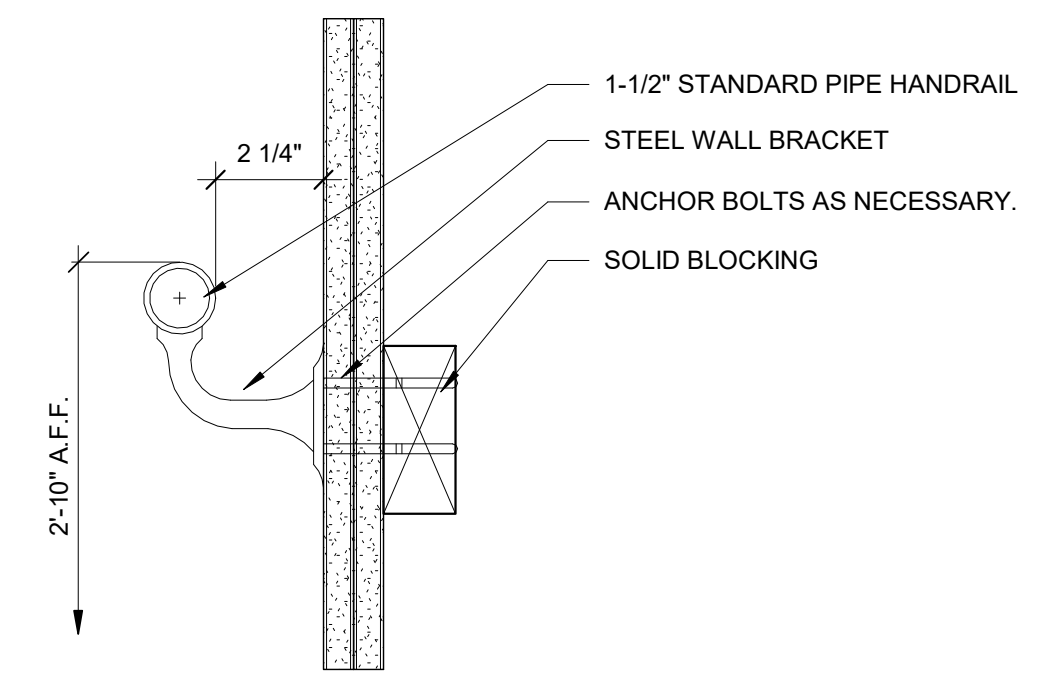

**3** STAIR - METAL HANDRAIL DETAIL - SECTION  
3" = 1'-0"

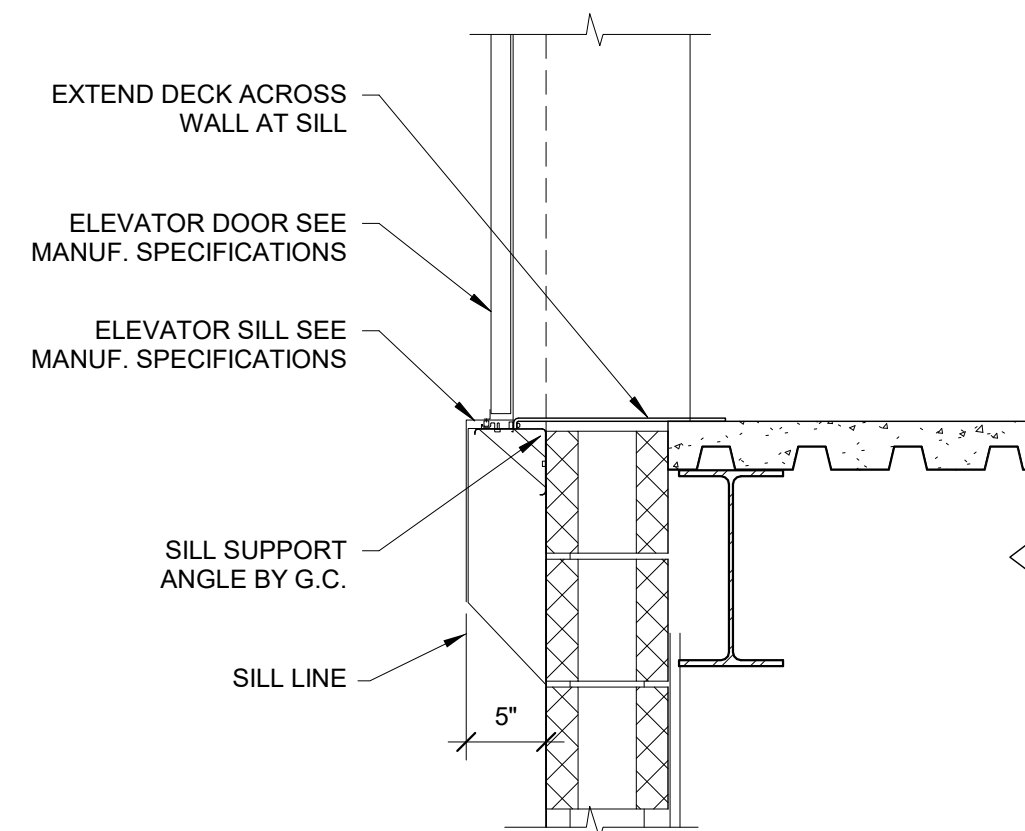

**11** ELEVATOR DOOR THRESHOLD  
1" = 1'-0"

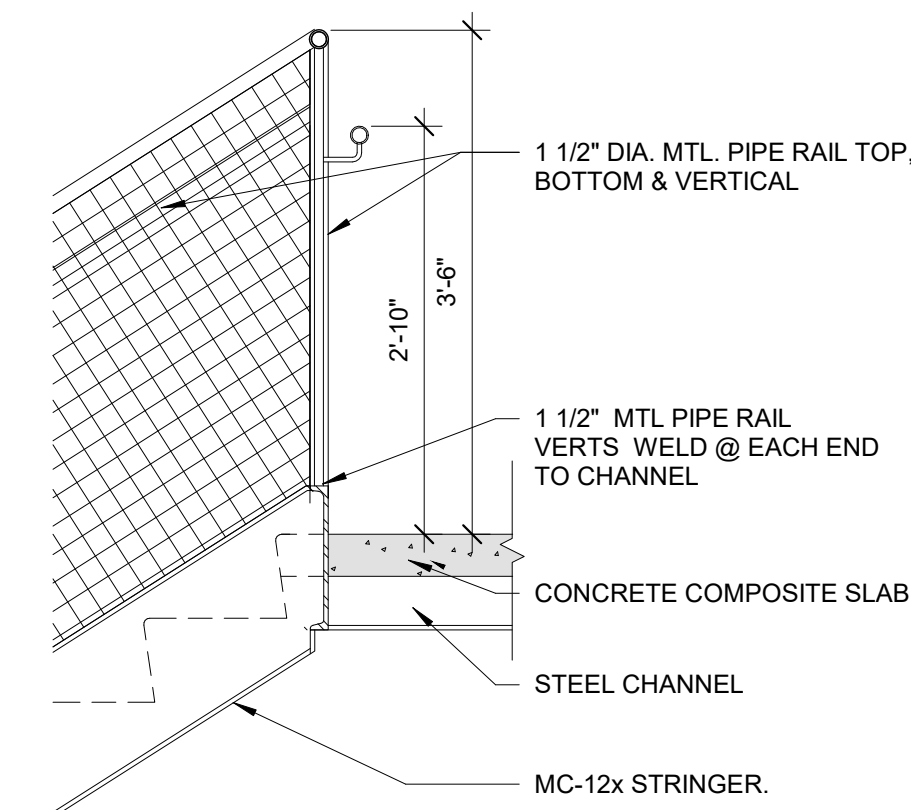

**7** STAIR DETAIL - T/O RUN TO DECK  
3/4" = 1'-0"

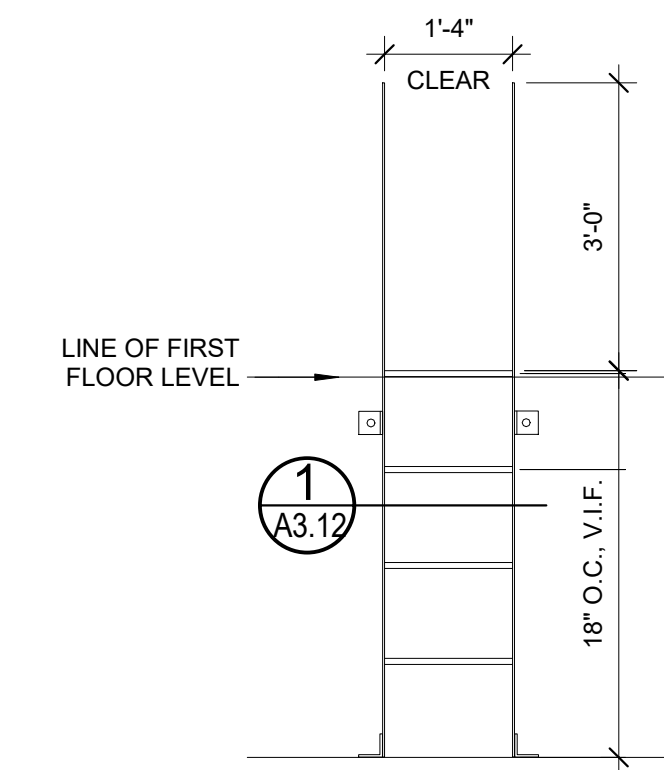

**2** ELEVATOR PIT LADDER ELEVATION  
1/2" = 1'-0"

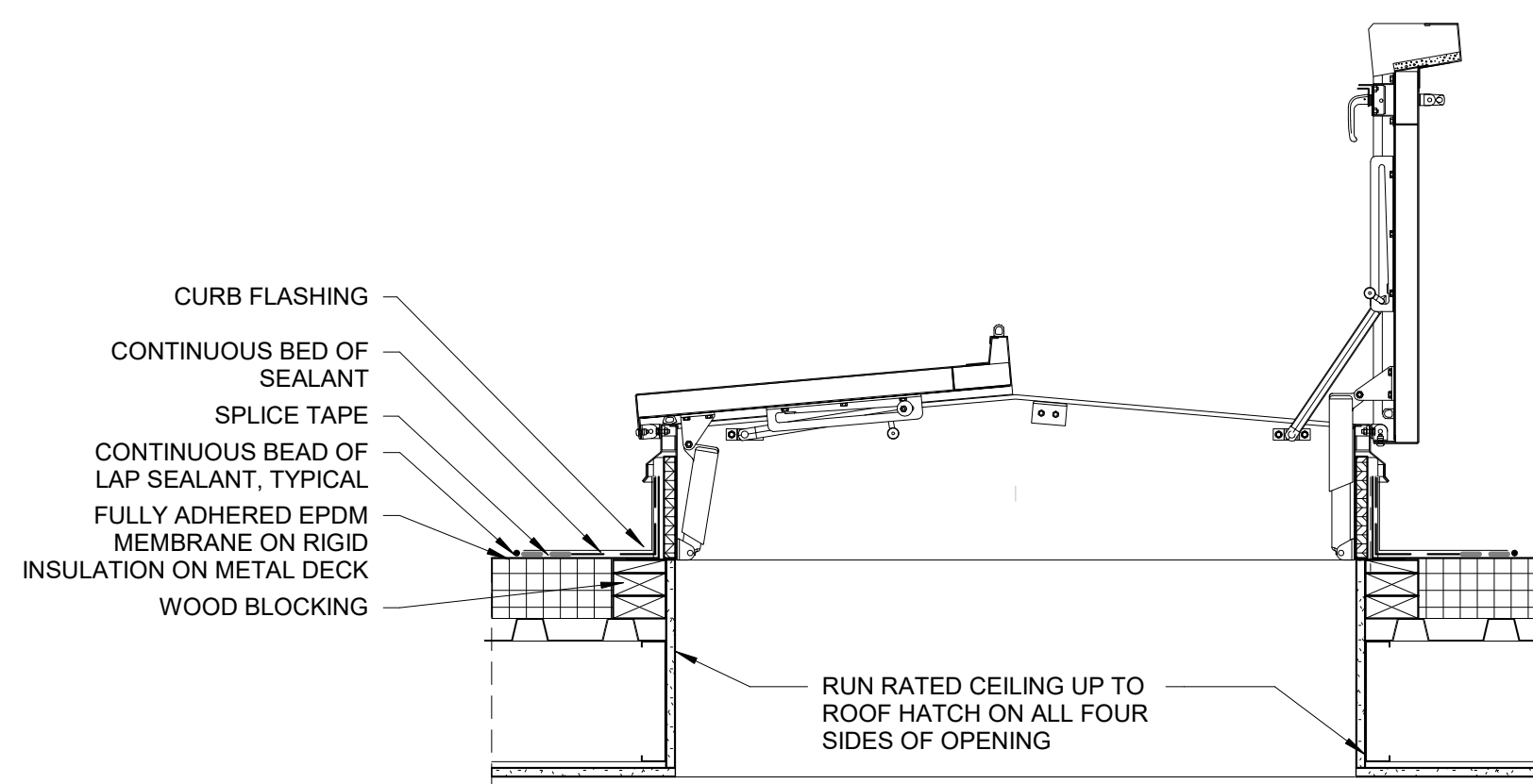

**13** ROOF DETAIL - ROOF HATCH  
1" = 1'-0"

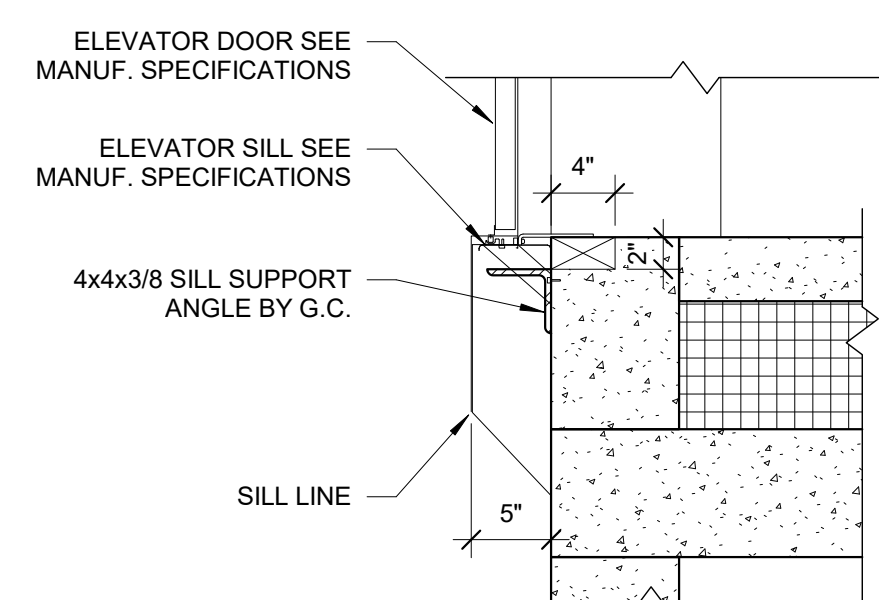

**10** ELEVATOR DOOR AT CONCRETE  
1" = 1'-0"

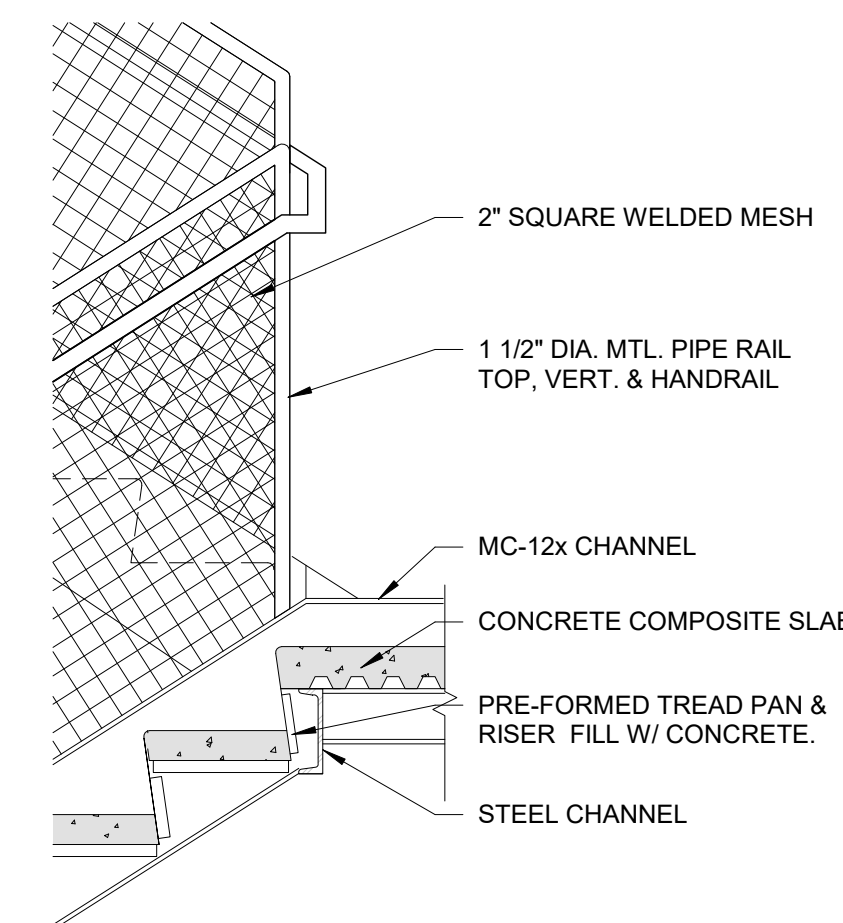

**6** STAIR DETAIL - T/O RUN TO LANDING  
3/4" = 1'-0"

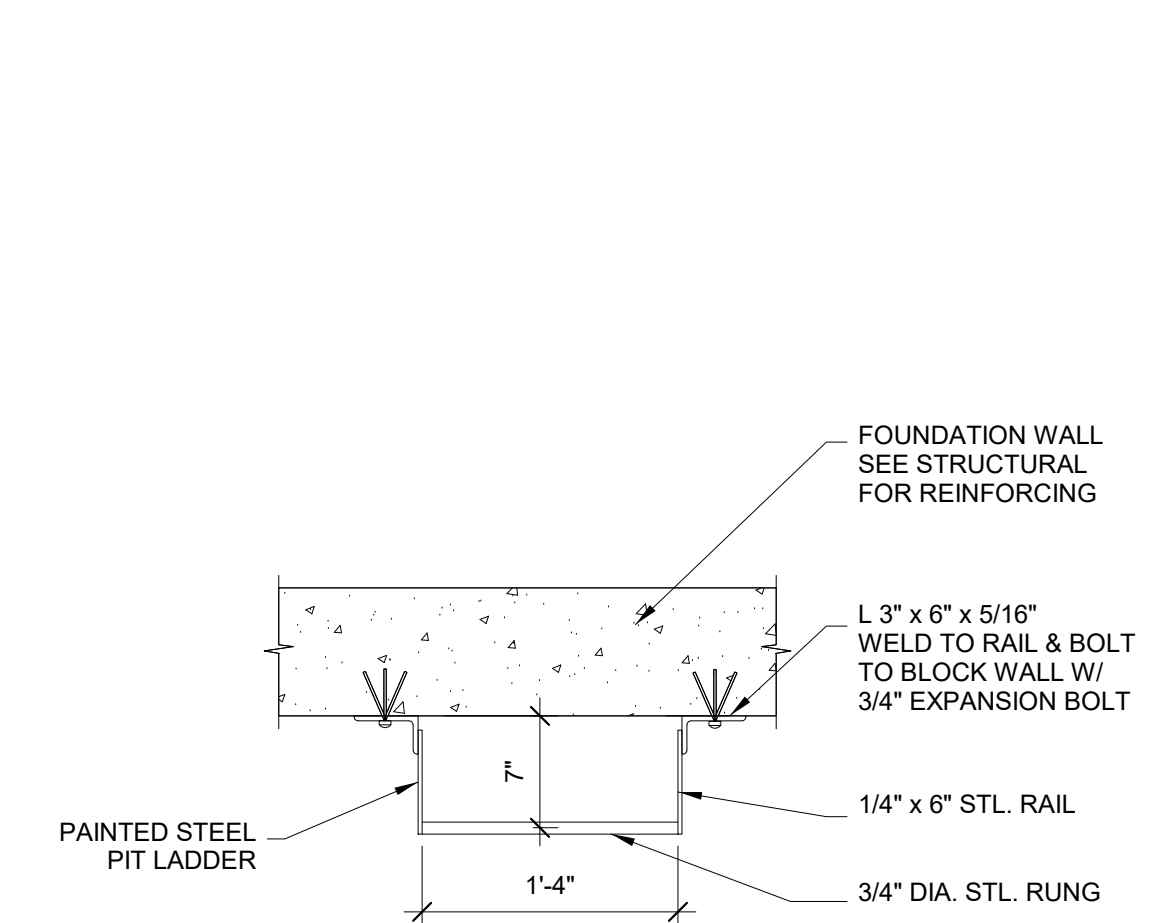

**1** ELEVATOR PIT LADDER PLAN  
1" = 1'-0"