



TriangleTube

Hot Water Specialists

prestige Excellence Water Boiler

Part 1 of 2

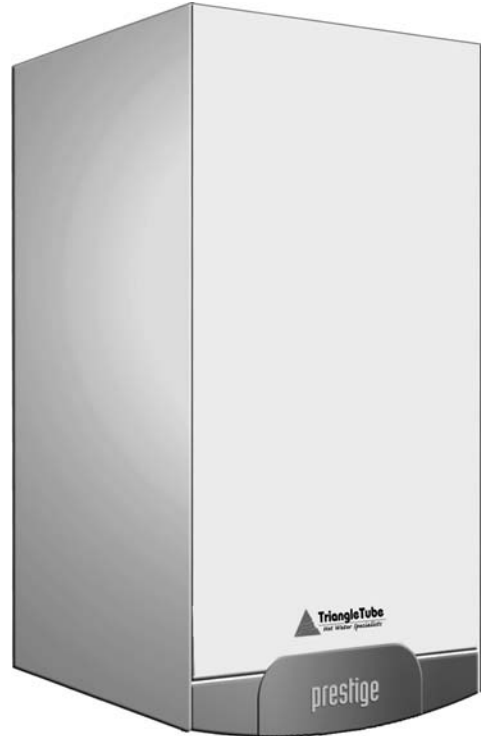

* INSTALLATION AND MAINTENANCE *

NOTICE

Warranty Registration Card must be filled out by the customer and mailed within thirty (30) days of installation in order to gain warranty coverage.

When receiving the PRESTIGE Excellence unit, any claims for damage or shortage in shipment must be filed immediately against the transportation company by the consignee.

Leave all documentation received with appliance with owner for future reference.

WARNING

If the information in this manual is not followed exactly, a fire or explosion may result causing property damage, personal injury or death.

FOR YOUR SAFETY

- Do not store or use gasoline or other flammable vapors and liquids in the vicinity of this or any other appliance.
- WHAT TO DO IF YOU SMELL GAS
 - Do not try to light any appliance
 - Do not touch any electrical switch; do not use any phone in your building.
 - Immediately call your gas supplier from a neighbor's phone. Follow the gas supplier's instructions.
 - If you cannot reach your gas supplier, call the fire department.

Installation and service must be performed by a qualified installer, service agency or the gas supplier.

WARNING

This manual outlines the requirements for installation of the PRESTIGE Excellence. Those requirements include Boiler Piping, Venting/Combustion Air, Start-Up and Maintenance.

- **For detailed instructions regarding the installation of the vent/combustion air system reference the PRESTIGE Vent Supplement and/or the various optional vent kit instructions.**
- **For instructions regarding the PRESTIGE Excellence Domestic Water Heater Installation requirements and piping, reference the PRESTIGE Excellence Indirect Water Heater Manual.**

The PRESTIGE Vent Supplement and PRESTIGE Excellence Indirect Water Heater Manual are included in the unit's installation envelope. For instructions or information regarding the various optional vent kits contact the Engineering Department at Triangle Tube.

PRODUCT AND SAFETY INFORMATION

Definitions 1
Product and Safety Information 2

SECTION I - PRE-INSTALLATION ITEMS

Code Compliance 3
Determining Product Location 3
Boiler Replacement 3
Recommended Clearances 4
Residential Garage Installations 4
Boiler Freeze Protection Feature 4

SECTION II - COMBUSTION AIR AND VENTING

Combustion Air Contamination 5
Ventilation and Combustion Air Requirements - Direct Vent 6
Ventilation and Combustion Air Requirements - Category IV 6
Methods of Accessing Combustion Air into a Space - Category IV 7
 - Indoor Combustion Air 7
 - Outdoor Combustion Air 7-8
 - Combination of Indoor and Outdoor Combustion Air 8-9
Combustion Air and Vent Piping 9
Removal of an Existing Boiler from a Common Vent System 10
Commonwealth of Massachusetts Installation 11

SECTION III - UNIT PREPARATIONS

Handling Instructions 12
Wall Mounting Installation 12
Wall Mounting Guidelines 12
Stud Walls - Installation 12
Wall Bracket Installation - Solid Walls 13
Boiler Mounting 13

SECTION IV - BOILER PIPING

General Piping Requirements 14
Pressure Relief Valve 14
Low Water Cut Off Device 14
Additional Limit Control 16

Backflow Preventer. 16

Boiler System Piping Applications. 16

Expansion Tank and Makeup Water. 16-17

 Diaphragm Expansion Tank 17

 Closed-Type Expansion Tank 17

Circulator 17

Sizing Primary Piping. 17

System Piping - Zone Circulators. 17

System Piping - Zone Valves 17

System Piping - Through Boiler. 18

System Piping - Radiant Heating 18

System Piping - Special Applications. 18

System Piping - Multiple Units Installation. 18

Near Boiler Piping Diagram. 19-20

Central Heating (CH) System Piping Diagrams. 21-24

SECTION V - INSTALLING VENT / COMBUSTION AIR & CONDENSATE DRAIN

Installing Vent and Combustion Air. 25

Installing Condensate Drain Assembly. 25-26

SECTION VI - GAS PIPING

Gas Supply Piping Connection. 27

Natural Gas

 Pipe Sizing -Natural Gas 28

 Natural Gas Supply Pressure Requirements. 28

Propane Gas

 Pipe Sizing - Propane Gas 29

 Propane Gas Supply Pressure Requirements 29-30

SECTION VII - INTERNAL WIRING

General Requirements. 31

Control Module Circulator AMP Ratings. 31

Wiring Tool Instructions. 31

Internal Wiring Diagram. 32

SECTION VIII - EXTERNAL WIRING

Installation Compliance 33

Line Voltage Connections. 33

Thermostat Wiring 33

System Circulator - Zone Valve Application 34
 Outdoor Reset Control 34
 Additional 24V Limit Wiring 34
 External Wiring Diagrams 34-36

SECTION IX - START-UP PREPARATION

Check Boiler System Water Chemistry
 Water pH Level 6.0 to 8.0 37
 Water Hardness Less Than 7 Grains. 37
 Chlorinated Water 37
 Flush System to Remove Sediment 37
 Check and Test Antifreeze 37
 Use of Antifreeze in the Boiler System 38
 Filling the Boiler System 38
 Check Low Water Cut-Off Device 39
 Check for Gas Leaks. 39
 Check Thermostat Circuit. 39
 Inspection of Condensate Drain Assembly. 39

SECTION X- START-UP PROCEDURES

Final Checks Before Start-Up. 40
 PRESTIGE Excellence Start-Up 40
 If PRESTIGE Excellence Does Not Start Correctly 40
 Check the PRESTIGE Excellence and System. 40-41
 Operating Instructions. 42
 Set Boiler CH Target Temperature 43
 Operation Verification - Space Heating 43-44
 Set DHW Storage Temperature 44
 Operation Verification - Domestic Hot Water 44-45
 Boiler Control Display
 Standby Mode. 45-46
 Setting the Boiler Parameters
 Parameter Mode 47
 Accessing Boiler Information.
 Information Mode. 47
 Error (Hard Lockout) Mode 48

SECTION XI - OUTDOOR RESET CONTROL

Mounting the Outdoor Sensor 49
 Wiring the Sensor 49

Summer/Winter Switch at Boiler 50
Boiler Target Temperature Setting 50
Setting the Boiler Target Temperature 50-51

SECTION XII - CHECK-OUT PROCEDURES

Check-Out Procedures 52

SECTION XIII - INSTALLATION RECORD

Installation Record 53

SECTIONS XIV - MAINTENANCE SCHEDULE

Service Technician - General 54
Owner Maintenance 54

SECTION XV - MAINTENANCE PROCEDURES

Maintenance Procedures
 Reported Problems 55
 Check Surrounding Area. 55
 Inspect Burner Area 55
 Check System Piping 55
 Clean Condensate Drain Assembly 56
 Check Ventilation Air Openings. 56
 Inspect Vent and Combustion Air Piping 56
 Check Boiler System 56
 Check Expansion Tank 57
 Check Boiler Relief Valve 57
 Inspection of Ignition Electrode 57
 Check Ignition Wiring and Ground Wiring 57
 Check Control Wiring. 58
 Check Control Settings. 58
 Perform Start-Up and Checkout Procedure 58
 Check Burner Flame. 58
 Check Flame Signal 59
 Check Combustion Levels 59
 Check Flue Gas Temperature 59
 Clean Heat Exchanger 59-60

Review with Owner 60
Handling Previously Fired Combustion Chamber Insulation 60

REPLACEMENT PARTS

Replacement Parts..... 61-64

PRODUCT SPECIFICATIONS

Specifications 65-69

Definitions

The following terms are used throughout this manual to bring attention to the presence of potential hazards or important information concerning the product.

DANGER

Indicates the presence of a hazardous situation which, if ignored, will result in death, serious injury or substantial property damage.

NOTICE

Indicates special instructions on installation, operation or maintenance, which are important to equipment but not related to personal injury hazards.

WARNING

Indicates a potentially hazardous situation which, if ignored, can result in death, serious injury or substantial property damage.

BEST PRACTICES

Indicates recommendations made by Triangle Tube for the installers which will help to ensure optimum operation and longevity of the equipment

CAUTION

Indicates a potentially hazardous situation which, if ignored, may result in minor injury or property damage.

NOTICE

Triangle Tube reserves the right to modify the technical specifications and components of its products without prior notice.

DANGER

Do not use this appliance if any part has been under water. Immediately call a qualified service technician to inspect the appliance and to replace any part of the control system which has been under water.

WARNING

WHAT TO DO IF YOU SMELL GAS

- Do not try to light any appliance
- Do not touch any electrical switch; do not use any phone in your building.
- Immediately call your gas supplier from a neighbor's phone. Follow the gas supplier's instructions.
- If you cannot reach your gas supplier, call the fire department.

Installation and service must be performed by a qualified installer, service agency or the gas supplier.

WARNING

Should overheating occur or the gas supply fails to shut off, turn OFF the manual gas control valve external to the appliance.

WARNING

DO NOT add cold make up water when the boiler is hot. Thermal shock can cause potential cracks in the heat exchanger.

CAUTION

When servicing the boiler:

- Avoid electrical shock by disconnecting the electrical supply prior to performing maintenance.

WARNING

Qualified Installer:

Prior to installing this product read all instructions included in this manual and all accompanying manuals/documents with this appliance. Perform all installation steps required in these manuals in the proper order given. Failure to adhere to the guidelines within these manuals can result in severe personal injury, death or substantial property damage.

Homeowner:

- This product should be maintained / serviced and inspected annually by a qualified service technician.
- This manual is intended for use by a qualified Installer/Service Technician.

NOTICE

Please reference the unit's model number and the serial number from the rating label on the backside of the control panel when inquiring about service or troubleshooting.

NOTICE

Triangle Tube accepts no liability for any damage resulting from incorrect installation or from the use of components or fittings not specified by Triangle Tube.

SECTION I - Pre-Installation Items

Code Compliance

This product must be installed in accordance to the following:

- All applicable local, state, national and provincial codes, ordinances, regulations and laws.
- For installations in Massachusetts - code requires the boiler to be installed by a licensed plumber or gas fitter, and if antifreeze is utilized, the installation of a reduced pressure backflow preventer device is required in the boiler's cold water fill or make up water supply line.
- For installation in Massachusetts
All direct vented appliances must comply with the guidelines as outlined on page 11.
- The National Fuel Gas Code NFPA54/ANSI Z 223.1 - Latest edition.
- National Electric Code ANSI/NFPA 70.
- For installations in Canada - "Installation Code for Gas Burning Equipment" CGA/B149.1 or B149.2 Canadian Electrical Code Part 1 CSA C22.1.
- Standards for Controls and Safety Devices for Automatically Fired Boilers, ANSI/ASME CSD-1, when required.

NOTICE

The PRESTIGE Excellence boiler gas manifold and gas controls meet the safe lighting and other performance requirements as specified in ANSI Z21.13 latest edition.

Determining Product Location

Before locating the PRESTIGE Excellence check for convenient locations to:

- Heating system piping
- Venting

- Gas supply piping
- Electrical service

Ensure the boiler location allows the combustion air/vent piping to be routed directly through the building and terminate properly outside with a minimum amount of length and bends.

Ensure the area chosen for the installation of the PRESTIGE Excellence is free of any combustible materials, gasoline and other flammable liquids.

WARNING

Failure to remove or maintain the area free of combustible materials, gasoline and other flammable liquids or vapors can result in severe personal injury, death or substantial property damage.

Ensure the PRESTIGE Excellence and its controls are protected from dripping or spraying water during normal operation or service.

The PRESTIGE Excellence should be installed in a location so that any water leaking from the boiler or piping connections or relief valve will not cause damage to the area surrounding the unit or any lower floors in the structure.

Boiler Replacement

If the PRESTIGE Excellence is replacing an existing boiler, the following items should be checked and corrected prior to installation:

- Boiler piping leaks and corrosion.
- Improper location and sizing of the expansion tank on the boiler heating loop.
- If applicable, level and quality of freeze protection within the boiler system.

Recommended Clearances

The PRESTIGE Excellence is approved for zero clearance to combustibles, excluding vent and boiler piping.

- Vent & Boiler Piping - 1/4 inch from combustible materials.

BEST PRACTICES

To provide serviceability to the unit it is recommended that the following clearances be maintained:

Top boiler jacket - 24 inches.

Front - 24 inches.

Bottom boiler piping - 24 inches.

Rear - 0 inches

Sides - 6 inches

WARNING

If the clearances listed above cannot be maintained, the space must be ventilated. See page 6 for ventilation requirements.

NOTICE

When maintaining zero clearance or less than recommended clearances, some product labeling may become hidden and unreadable

WARNING

When installing the PRESTIGE Excellence in a confined space, sufficient air must be provided for proper combustion and venting and to allow, under normal operating conditions, proper air flow around the product to maintain ambient temperatures within safe limits to comply with the National Fuel Gas Code NFPA 54 - latest edition.

Residential Garage Installations

When installing the PRESTIGE Excellence in a residential garage, the following special precautions per NFPA 54/ANSI Z223.1 must be taken:

- Mount the unit with a minimum 18 inches above the floor level of the garage. Ensure the burner and ignition devices / controls are no less than 18 inches above the floor level.
- Locate or protect the unit in a manner so it cannot be damaged by a moving vehicle.

Boiler Freeze Protection Feature

The boiler control has an freeze protection feature built in. This feature monitors the boiler temperature and responds as follows when no call for heat is present:

- 46°F Boiler circulator is ON
- 38°F Boiler circulator is ON and burner operates at low fire
- 50°F Burner OFF and boiler circulator operates for approximately 10 minutes

CAUTION

The boiler freeze protection feature is disabled during a hard lockout, however the CH circulator will operate and the 3-way valve will open to the CH system.

CAUTION

The boiler freeze protection feature is designed to protect the boiler and should be installed in a primary/secondary piping arrangement. If it is installed in an unheated space or exposed to water temperatures of 46°F or less, see Section IV for primary/secondary piping examples. See Section IX for antifreeze guidelines.

SECTION II - Combustion Air and Venting

Combustion Air Contamination

WARNING

If the PRESTIGE Excellence combustion air inlet is located in any area likely to cause or contain contamination, or if products, which would contaminate the air cannot be removed, the combustion air must be repiped and terminated to another location. Contaminated combustion air will damage the unit and its burner system, resulting in possible severe personal injury, death or substantial property damage.

WARNING

Do not operate a PRESTIGE Excellence if its combustion air inlet is located near a laundry room or pool facility. These areas will always contain hazardous contaminants.

Pool and laundry products and common household and hobby products often contain fluorine or chlorine compounds. When these chemicals pass through the burner and vent system, they can form strong acids. These acids can create corrosion of the heat exchanger, burner components and vent system, causing serious damage and presenting a possible threat of flue gas spillage or water leakage into the surrounding area.

Please read the information listed below. If contaminating chemicals are located near the area of the combustion air inlet, the installer should pipe the combustion air inlet to an outside area free of these chemicals per SECTION V of this installation manual.

Potential contaminating products

- Spray cans containing chloro/fluorocarbons
- Permanent Wave Solutions
- Chlorinated wax
- Chlorine - based swimming pool chemicals / cleaners
- Calcium Chloride used for thawing ice
- Sodium Chloride used for water softening
- Refrigerant leaks
- Paint or varnish removers
- Hydrochloric acid / muriatic acid
- Cements and glues
- Antistatic fabric softeners used in clothe dryers
- Chlorine-type bleaches, detergents, and cleaning solvents found in household laundry rooms
- Adhesives used to fasten building products and other similar products

Areas likely to contain these products

- Dry cleaning / laundry areas and establishments
- Beauty salons
- Metal fabrication shops
- Swimming pools and health spas
- Refrigeration Repair shops
- Photo processing plants
- Auto body shops
- Plastic manufacturing plants
- Furniture refinishing areas and establishments
- New building construction
- Remodeling areas
- Garages with workshops

Ventilation and Combustion Air Requirements - Direct Vent

A Direct Vent appliance utilizes uncontaminated outdoor air (piped directly to the appliance) for combustion)

For Direct Vent installations, involving only the PRESTIGE Excellence, in which the minimum service clearances are maintained as listed on page 4, no ventilation openings are required.

For Direct Vent, zero clearance installations involving only the PRESTIGE Excellence, the space / enclosure must provide two openings for ventilation. The openings must be sized to provide 1 square inch of free area per 1,000 BTUH of boiler input. The openings shall be placed 12 inches from the top of the space and 12 inches from the floor of the space.

For installations in which the PRESTIGE Excellence shares the space with air movers (exhaust fan, clothes dryers, fireplaces, etc.) and other combustion equipment (gas or oil) the space must be provided with adequate air openings to provide ventilation and combustion air to the equipment. To properly size the ventilation / combustion air openings, the installer must comply with the National Fuel Gas Code NFPA 54, ANSI Z223.1 for installations in the U.S or CSA B149.1 and B149.2 for installations in Canada.

WARNING

The space must be provided with ventilation / combustion air openings properly sized for all make-up air requirements (exhaust fans, clothes dryers, fireplaces, etc.) and the total input of all appliances located in the same space as the PRESTIGE Excellence, excluding the input of a Direct Vent PRESTIGE Excellence which uses combustion air directly from the outside, thus additional free area for the openings is not required. Failure to provide or properly size the openings could result in severe personal injury, death or substantial property damage.

Ventilation and Combustion Air Requirements - Category IV

A Category IV appliance utilizes uncontaminated indoor or outdoor air (surrounding the appliance) for combustion.

BEST PRACTICES

In order to reduce the potential risks associated with indoor contaminants (listed on page 5), flammable vapors and tight housing construction (little or no infiltration air), it is recommended to pipe uncontaminated combustion air directly from the outdoors to the appliance. This practice also promotes higher system efficiency by reducing heated indoor air from being exhausted from the house and replaced by cold infiltration air into the house.

For installations in which the PRESTIGE Excellence shares the space with air movers (exhaust fan, clothes dryers, fireplaces, etc.) and other combustion equipment (gas or oil) the space must be provided with adequate air openings to provide ventilation and combustion air to the equipment. To properly size the ventilation / combustion air openings, the installer must comply with the National Fuel Gas Code NFPA 54, ANSI Z223.1 for installations in the U.S or CSA B149.1 and B149.2 for installations in Canada, as referenced in this section of the manual and titled Methods of Accessing Combustion Air into a Space.

WARNING

The space must be provided with ventilation / combustion air openings properly sized for all make-up air requirements (exhaust fans, clothes dryers, fireplaces, etc.) and the total input of all appliances, including the PRESTIGE Excellence when located in the same space as the PRESTIGE Excellence. Failure to provide or properly size the openings could result in severe personal injury, death or substantial property damage.

Methods of Accessing Combustion Air Into A Space - Category IV

Indoor Combustion Air

NOTICE

The methods listed in this section for accessing Indoor Combustion Air assume that the infiltration rate is adequate and not less than .40 ACH. For infiltration rates less than .40 ACH, reference the NFPA 54 National Fuel Gas Code for additional guidance.

Opening Size and Location

Openings used to connect indoor spaces shall be sized and located in accordance with the following. See Fig. 1:

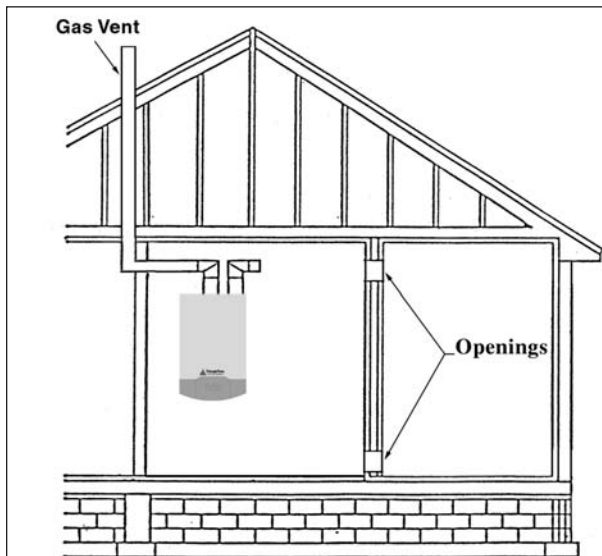

Fig. 1: All Combustion Air from Adjacent Indoor Spaces Through Indoor Combustion Openings

- Combining spaces on the same story. Each opening shall have a minimum free area of 1 sq. in./1000 Btu/hr of the total input rating of all gas utilization equipment in the space, but not less than 100 sq. inches. One opening shall commence within 12 inches of the top, and one opening shall commence within 12

inches of the bottom of the enclosure. The minimum dimension of air openings shall be not less than 3 inches.

- Combining spaces in different stories. The volumes of spaces in different stories shall be considered as communicating spaces where such spaces are connected by one or more openings in doors or floors having a total minimum free area of 2 sq. in./1000 Btu/hr of total input rating of all gas utilization equipment.

Outdoor Combustion Air

BEST PRACTICES

Isolating the combustion appliance room from the rest of the building and bringing in uncontaminated outside air for combustion and ventilation is always preferred.

Opening Size and Location

The minimum dimension of air openings shall be not less than 3 inches

Openings used to supply combustion and ventilation air shall be sized and located in accordance with the following:

One Permanent Opening Method. See Fig. 2

One permanent opening, commencing within 12 in. of the top of the enclosure, shall be provided. The equipment shall have clearances of at least 1 inch from the sides and 6 in. from the front of the appliance. The opening shall directly communicate with the outdoors or shall communicate through a vertical or horizontal duct to the outdoors or spaces that freely communicate with the outdoors and shall have a minimum free area of the following:

- 1sq. in./3000 Btu/hr of the total input rating of all equipment located in the enclosures, and

- Not less than the sum of the areas of all vent connectors in the space.

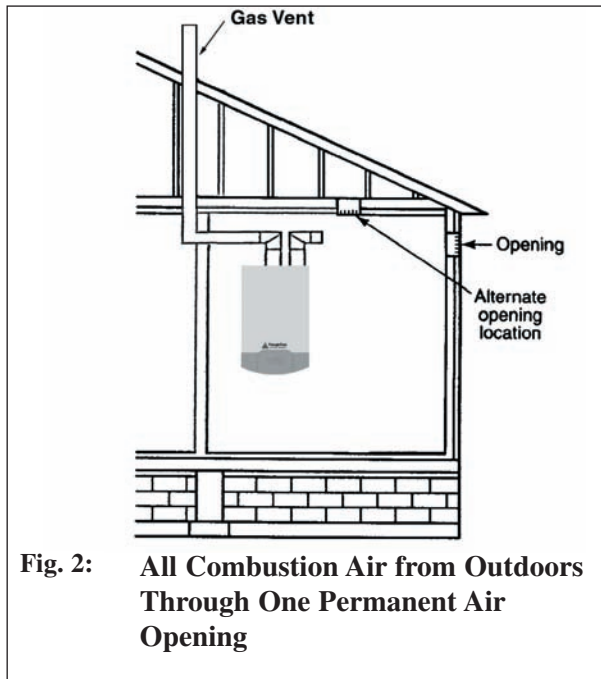

Two Permanent Openings Method.

Two permanent openings, one commencing within 12 in. of the top and one commencing within 12 in. of the bottom of the enclosure, shall be provided. The openings shall communicate directly, or by ducts, with the outdoors or spaces that freely communicate with the outdoors, as follows:

- Where directly communicating with the outdoors or where communication to the outdoors is through vertical ducts, each opening shall have a minimum free area of 1 sq. in./4000 Btu/hr of total input rating of all equipment in the enclosure. See Fig.3.
- Where communicating with the outdoors is through horizontal ducts, each opening shall have a minimum free area of not less than 1 sq.in./2000 Btu/hr of total input rating of all equipment in the enclosure. See Fig. 4.

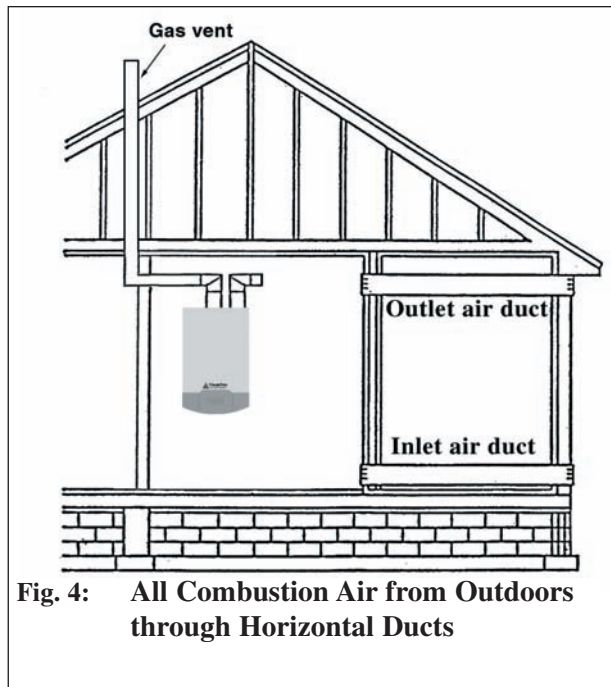
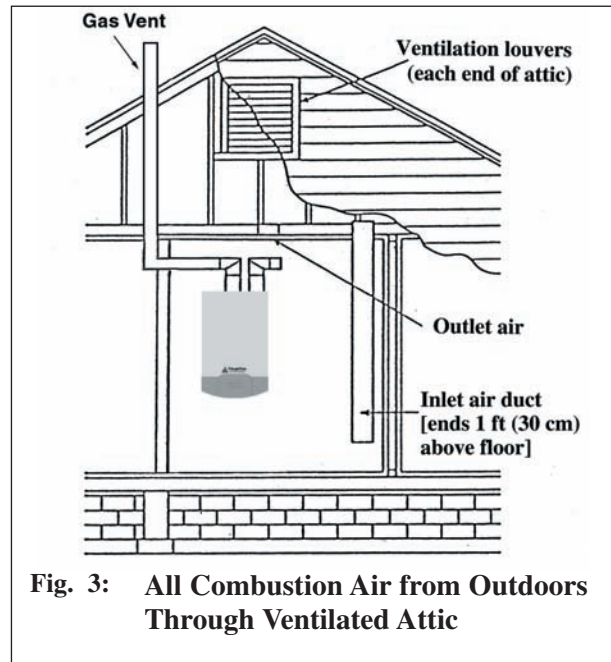

Combination of Indoor and Outdoor Combustion Air

Indoor Openings: Where used, openings connecting the interior spaces shall comply with the Indoor Combustion Air section on page 7.

Outdoor Opening(s) Location. Outdoor opening(s) shall be located in accordance with the Outdoor Combustion Air section.

Outdoor Opening(s) Size. Outdoor opening(s) shall be calculated in accordance with the following:

- The ratio of the interior spaces shall be the available volume of all communicating spaces divided by the required volume.
- The outdoor size reduction factor shall be 1 minus the ratio of interior spaces.
- The minimum size of outdoor opening(s) calculated in accordance with the above outdoor air section multiplied by the reduction factor. The minimum dimension of air openings shall not be less than 3 in.

DANGER

Do not install the PRESTIGE Excellence into a common vent with other gas or oil appliances. This may cause flue gas spillage or appliance malfunction, resulting in possible severe personal injury, death or substantial property damage.

Combustion Air and Vent Piping

The PRESTIGE Excellence requires a Category IV venting system, which is designed for pressurized venting and condensate.

The PRESTIGE Excellence is certified per ANSI Z21.13 as a Category IV or Direct Vent (sealed combustion) appliance. A Category IV appliance utilizes uncontaminated indoor or outdoor air (surrounding the appliance) for combustion. A Direct Vent appliance utilizes uncontaminated outdoor air (piped directly to the appliance) for combustion.

BEST PRACTICES

In order to reduce the potential risks associated with indoor contaminants (listed on page 5), flammable vapors and tight housing construction (little or no infiltration air), it is recommended to pipe uncontaminated combustion air directly from the outdoors to the appliance. This practice also promotes higher system efficiency by reducing heated indoor air from being exhausted from the house and replaced by cold infiltration air into the house.

NOTICE

Install combustion air and vent pipe as detailed in the PRESTIGE Vent Supplement included in the boiler installation envelope. Refer to optional vent kit instructions for additional vent installation instructions.

DANGER

Verify installed combustion air and vent piping are sealed gas tight and meet all provided instructions and applicable codes, failure to comply will result in severe personal injury or death.

Removal of an Existing Boiler from a Common Vent System

BEST PRACTICES

When an existing boiler is removed from a common venting system, the common venting system is likely to be too large for proper venting of the remaining appliances. At the time of removal of an existing boiler, the following steps shall be followed with each appliance remaining connected to the common venting system placed in operation, while the other appliances remaining connected to the common venting system are not in operation.

1. Seal any unused openings in the common venting system.
2. Visually inspect the venting system for proper size and horizontal pitch and determine there is no blockage or restriction, leakage, corrosion and other deficiencies which could cause an unsafe condition.
3. Insofar as is practical, close all building doors and windows and all doors between the space in which the appliances remaining connected to the common venting system are located and other spaces of the building. Turn on clothes dryers and any appliance not connected to the common venting system. Turn on any exhaust fans, such as range hoods and bathroom exhausts, so they will operate at maximum speed. Do not operate a summer exhaust fan. Close fireplace dampers.
4. Place in operation the appliance being inspected. Follow the lighting instructions. Adjust thermostat so appliance will operate continuously.
5. Test for spillage at the draft hood relief opening after 5 minutes of main burner operation. Use the flame of a match or candle, or smoke from a cigarette, cigar or pipe.
6. After it has been determined that each appliance remaining connected to the common venting system properly vents when tested as outlined above, return doors, windows, exhaust fans, fireplace dampers, and any other gas-burning appliance to their previous condition of use.
7. Any improper operation of the common venting system should be corrected so the installation conforms with the National Fuel Gas Code, ANSI Z223.1/NFPA 54 and/or CAN/CGA B149, Installation codes. When resizing any portion of the common venting system, the common venting system should be resized to approach the minimum size as determined using the appropriate tables in Part II of the National Fuel Gas Code ANSI Z223.1/NFPA 54 and/or CAN/CGA B149, Installation codes.

DANGER

Do not install the PRESTIGE Excellence into a common vent with other gas or oil appliances. This may cause flue gas spillage or appliance malfunction, resulting in possible severe personal injury, death or substantial property damage.

Commonwealth of Massachusetts Installations Only

For direct-vent appliances, mechanical-vent heating appliances or domestic hot water equipment, where the bottom of the vent terminal and the air intake is installed below four feet above grade the following requirements must be satisfied:

1. If there is not one already present, on each floor level where there are bedroom(s), a carbon monoxide detector and alarm shall be placed in the living area outside the bedroom(s). The carbon monoxide detector shall comply with NFPA 720 (2005 Edition).
2. A carbon monoxide detector shall be located in the room that houses the appliance or equipment and shall:
 - a. Be powered by the same electrical circuit as the appliance or equipment such that only one service switch services both the appliance and the carbon monoxide detector;
 - b. Have battery back-up power;
 - c. Meet ANSI/UL 2034 Standards and comply with NFPA 720 (2005 Edition); and
 - d. Have been approved and listed by the Nationally Recognized Testing Laboratory as recognized under 527 CMR.
3. A Product-approved vent terminal must be used, and if applicable, a Product-approved air intake must be used. Installation shall be in strict compliance with the manufacturer's instructions. A copy of the installation instructions shall remain with the appliance or equipment at the completion of the installation.

4. A metal or plastic identification plate shall be mounted at the exterior of the building, four feet directly above the location of vent terminal. The plate shall be of sufficient size to be easily read from a distance of eight feet away, and read "**Gas Vent Directly Below**".

NOTICE

Installer must provide tag identification plate and ensure the lettering meets code requirements.

For direct-vent appliances, mechanical-vent heating appliances or domestic hot water equipment, where the bottom of the vent terminal and the air intake are installed above four feet above grade the following requirements must be satisfied:

1. If there is not one already present, on each floor level where there are bedroom(s), a carbon monoxide detector and alarm shall be placed in the living area outside the bedroom(s). The carbon monoxide detector shall comply with NFPA 720 (2005 Edition).
2. A carbon monoxide detector shall:
 - a. Be located in the rooms that houses the appliances or equipment;
 - b. Be either hard wired or battery powered or both; and
 - c. Shall comply with NFPA 720 (2005 Edition)
3. A Product-approved vent terminal must be used, and if applicable, a Product-approved air intake must be used. Installation shall be in strict compliance with the manufacturer's instructions. A copy of the installation instructions shall remain with the appliance or equipment at the completion of the installation.

SECTION III - Unit Preparations

Handling Instructions

The PRESTIGE Excellence is generally easier to handle and maneuver once removed from the shipping carton and pallet.

To remove the shipping carton and pallet:

CAUTION

Use care not to lift the unit from, or place the unit on the front plastic control panel, damage can occur. Use care not to drop, bump or rotate the boiler upside down, as damage to the boiler will result.

1. Remove any shipping straps and open the side of the shipping carton.
2. Slide the unit with the foam inserts out of the carton.
3. Discard all packing materials.

Wall Mounting Installation

The PRESTIGE Excellence should be wall mounted using the bracket kit provided with the boiler. The PRESTIGE is not designed for floor installation. If floor installation is required an optional floor stand is available through Triangle Tube.

WARNING

The wall used for mounting the PRESTIGE Excellence must be vertically plumbed and capable of supporting a minimum 250 pounds [113 Kg]. Failure to comply with these requirements could result in personal injury, death or substantial property damage.

Wall Mounting Guidelines

1. The wall frame kit is designed for stud spacing of 12 inch or 16 inch on centers. For unconventional stud spacing, a solid /

secure mounting surface must be provided for installation of the bracket.

2. DO NOT mount or attempt to mount the wall bracket to hollow sheet rock or lathe walls using anchors. Only install boiler to studs or equivalent wood structure.
3. For applications using solid walls (rock, concrete, brick, cinder block, etc.), install the wall bracket using anchors (double expansion shields) and bolts with washers provided with the boiler.
4. The boiler is too heavy and bulky for a single person to lift and attempt to mount; a minimum of 2 people is required for mounting the boiler.

WARNING

Use extreme care not to drop the boiler or cause bodily injury while lifting or mounting the boiler onto the bracket. Once mounted verify that the boiler is securely attached to the bracket and wall. Failure to comply with the above guidelines could result in property damage, personal injury or death.

Stud Walls -Installation

1. To distribute the weight of the boiler evenly when mounting onto a stud wall it is recommended to use the PRESTIGE Wall Frame kit.
2. When using the wall frame to mount the boiler reference the kit installation instructions and ensure the frame is securely fastened to the wall.
3. If the structure of wall is questionable, in supporting a minimum weight of 250 pounds [113 Kg.], it is recommended to use the optional floor stand.

Wall Bracket Installation - Solid Walls

1. Locate the general area of the boiler placement.
2. Place the wall-mounting bracket on the wall ensuring the upper edge of the bracket is away from the wall.
3. Level the bracket and use a pencil to mark the location of the mounting slots on the wall.
4. Remove the bracket from the wall and drill a 5/8" diameter hole by 1-3/8" deep positioned in the center of each mark.
5. Install the anchors (provided) flush or slightly recessed in the drilled holes with threaded side facing down.

6. Reposition the bracket on the wall and align mounting slots/holes. Insert the two bolts (provided) through the mounting slots/holes and loosely tighten.
7. Level bracket and tighten bolts securely.

Boiler Mounting

1. Obtain assistance in lifting the boiler onto the wall bracket.
2. Install the boiler making sure the boiler mounting lip located along the upper edge of the rear jacket panel engages the wall-mounting bracket. Ensure the boiler is seated properly and is secure.

SECTION IV - Boiler Piping

General Piping Requirements

- All plumbing must meet or exceed all local, state and national plumbing codes.
- Support all piping using hangers. DO NOT support piping by the unit or its components.
- Use isolation valves to isolate system components.
- Install unions for easy removal of the PRESTIGE Excellence from the system piping.
- If plastic pipe is used for boiler water piping, it must have a maximum oxygen diffusion rate of 0.1 mg/liter-day for boiler and water heater protection.

WARNING

Use a two wrench method when tightening piping onto the boiler connections. Use one wrench to prevent the boiler piping from turning / twisting. Failure to support the boiler piping and connections in this manner could cause damage to the boiler and its components.

Pressure Relief Valve

1. The PRESTIGE Excellence is supplied with a 30 psi pressure relief valve and must be piped using the PRV connection as shown in Fig. 5 page 15.
2. To avoid potential water damage to the surrounding area or potential scalding hazard due to the operation of the relief valve, the discharge piping:
 - Must be connected to the discharge outlet of the relief valve and directed to a safe place of disposal.
 - Length should be as short and direct as possible. The size of the discharge line should not be reduced, maintain the same size as the outlet of the relief valve.

- Should be directed downward towards the floor at all times. The piping should terminate at least 6 inches above any drain connection to allow clear visibility of the discharge.
- Should terminate with a plain end, not with a threaded end. The material of the piping should have a serviceable temperature rating of 250°F or greater.
- Should not be subject to conditions where freezing could occur.
- Should not contain any shut-off valves or obstructions. No shut-off valve should be piped between the boiler and relief valve.

WARNING

Failure to comply with the guidelines on installing the pressure relief valve and discharge piping can result in personal injury, death or substantial property damage.

Low Water Cutoff Device

- The PRESTIGE Excellence is equipped with a factory installed pressure switch type Low Water Cut Off device.
- The minimum operating system pressure allowable with this device is 10 psig.
- Check local codes if a Low Water Cutoff Device is required. If so, determine if this device meets the requirements of the local codes.

NOTICE

The PRESTIGE Excellence control system also uses the sensing of the system water temperatures entering and exiting the heat exchanger to provide protection against low water conditions. Where local codes and jurisdiction do not accept a pressure device for low water protection, the jurisdictions may accept these PRESTIGE Excellence integral control functions as a means of providing low water protection.

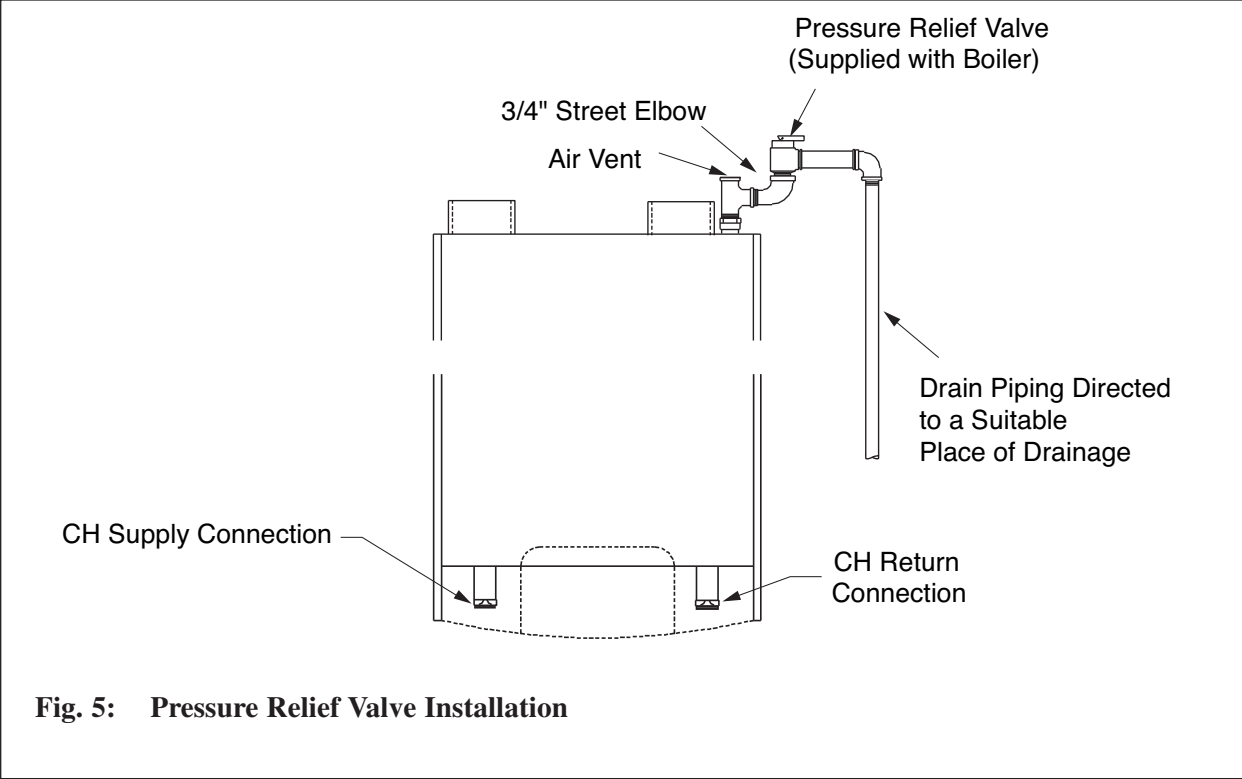

Fig. 5: Pressure Relief Valve Installation

Additional Limit Control

If a separate LWCO device is required by certain local jurisdictions or when the boiler is installed above the system piping, the following guidelines must be followed:

- The LWCO device must be designed for water installations, electrode probe-type is recommended.
- The LWCO device must be installed in a tee connection on the boiler supply piping above the boiler.
- Wiring of the LWCO device to the PRES-TIGE Excellence is done directly onto the 24V terminal strip, reference Fig. 20 page 32 for available terminals for an external limit (manual or auto reset).

If the installation is to comply with ASME or Canadian requirements, an additional high temperature limit may be needed. Consult local code requirements to determine compliance. The limit should be installed as follows:

- Install the limit in the boiler supply piping between the boiler and any isolation valve.
- Maximum set point for the limit is 194°F.
- For wiring of the limit reference Fig. 20, page 32, using the external limit/manual reset terminals on the 24V terminal strip. This will provide a "hard" lockout requiring a manual reset of the control.

Backflow Preventer

- Use a backflow preventer valve in the make-up water supply to the unit as required by local codes.

Boiler System Piping Applications

BEST PRACTICE

It is recommended on all piping applications to utilize a primary/secondary piping arrangement as a means to provide freeze protection of the boiler, which is an integral function of the boiler control. Maintain the minimum boiler flow rate, see Graph 2 on page 69. For other piping arrangements, consult the Engineering Department at Triangle Tube or consult other approved/recognized design arrangement.

BEST PRACTICE

On piping applications utilizing a single zone or other recognized piping design arrangements, it is recommended that the installer uses flow/check valves with weighted seats at or near the appliance to prevent gravity circulation.

Expansion Tank and Makeup Water

Ensure the expansion tank is properly sized for the boiler volume (5 gallons [19 L]) and the system volume and temperature.

CAUTION

Undersized expansion tanks will cause system water to be lost through the pressure relief valve and cause additional makeup water to be added to the system. Eventual boiler heat exchanger failure can result due to this excessive makeup water addition.

The expansion tank must be located as shown in Fig. 6 and Fig. 7 on pages 19 & 20 or as per recognized design methods. Refer to the expansion tank manufacturer instructions for additional installation details.

Connect the expansion tank to an air separator only if the air separator is located on the suction side (inlet) of the system circulator. Always locate and install the system fill connection at the same location as the expansion tank connection to the system.

Diaphragm Expansion Tank

Always install an automatic air vent on the top of the air separator to remove residual air from the system.

Closed-Type Expansion Tank

It is recommended to pitch any horizontal piping upwards toward the expansion tank 1 inch per 5 feet of piping. Use 3/4" piping for the expansion tank to allow air within the system to rise.

CAUTION

DO NOT install automatic air vents on a closed-type expansion tank system. Air must remain in the system and be returned to the expansion tank to provide an air cushion. An automatic air vent would cause air to be vented from the system resulting in a water-logged expansion tank.

Circulator

The PRESTIGE Excellence is supplied with a boiler circulator that provides circulation for space (CH) heating and domestic (DHW) hot water production. See Graph 2 on page 69 for pressure drop and minimum flow rate through the boiler.

Sizing Primary Piping

See Fig. 9 through 14, pages 21 - 24, for recommended piping arrangements based on various applications.

Size the piping and system components required in the space heating system, using recognized design methods.

System Piping - Zone Circulators

Connect the PRESTIGE Excellence to the system piping as shown in Fig. 9 page 21 when zoning with zone circulators.

The installer must provide a separate circulator for each zone of space heating.

NOTICE

To ensure adequate flow rate through the PRESTIGE Excellence, maintain a minimum 1 inch diameter on the system piping connecting to the boiler.

System Piping - Zone Valves

Connect the PRESTIGE Excellence to the system piping as shown in Fig. 10 page 21 when zoning with zone valves. The primary / secondary piping ensures that the boiler loop has sufficient flow.

NOTICE

To ensure adequate flow rate through the PRESTIGE Excellence, maintain a minimum 1 inch diameter on the system piping connecting to the boiler.

System Piping - Through Boiler

In applications in which primary/secondary piping is not utilized and the system is zoned with zone valves a circulator could pump through the boiler and system directly. When pumping through with more than one zone, a pressure differential bypass valve is required to avoid dead heading the pump through the post pump feature of the control. Consult Fig. 11 and 12 page 22 for piping diagrams and Graph 2 on page 69 for proper circulator sizing.

System Piping - Radiant Heating

The heat exchanger design of the PRESTIGE Excellence allows operation in a condensing mode. This feature requires no regulation of the return water temperature back to the boiler in radiant heating applications.

The boiler water supply temperature can be maintained by the PRESTIGE Excellence, eliminating the need for a mix system to achieve the desired temperature.

It is recommended for the installer to add a high temperature limit as shown in Fig.13 page 23. This will ensure that the primary supply temperature does not exceed the maximum allowable temperature for the radiant tubing.

BEST PRACTICE

The addition of the high temperature limit is important when the PRESTIGE Excellence has completed a DHW mode, which requires a high primary supply water temperature.

NOTICE

Due to the construction of the water heater, do not install the PRESTIGE Excellence if the boiler piping contains non-oxygen barrier tubing if the boiler piping is considered an “open system”. Exposing the outer tank of the PRESTIGE Excellence water heater to oxygen contamination will lead to premature tank failure and denial of the warranty.

Size the system piping and circulator to provide the flow needed for the radiant system.

NOTICE

To ensure adequate flow rate through the PRESTIGE Excellence, maintain a minimum 1 inch diameter on the system piping connecting to the boiler.

System Piping - Special Application

If the boiler is used in conjunction with a chilled water/medium system, the boiler and chiller must be piped in parallel. Install flow/check valves to prevent the chilled medium from entering into the boiler.

If the boiler is used to supply hot water to the heating coils of an air handler where they may be exposed to chilled air circulation, install flow/check valves or other automatic means to prevent gravity circulation of the boiler water during cooling cycles.

System Piping - Multiple Units Installation

Use a balanced manifold system as the primary / secondary connection to the space heating piping as shown in Fig. 14 page 24.

Maintain a minimum of 6 inches of clearance between units to allow for servicing.

Refer to Figs. 6 and 7 pages 19 & 20 to install air separator and expansion tank.

For the space heating piping refer to the applications mentioned in this manual or use recognized design methods.

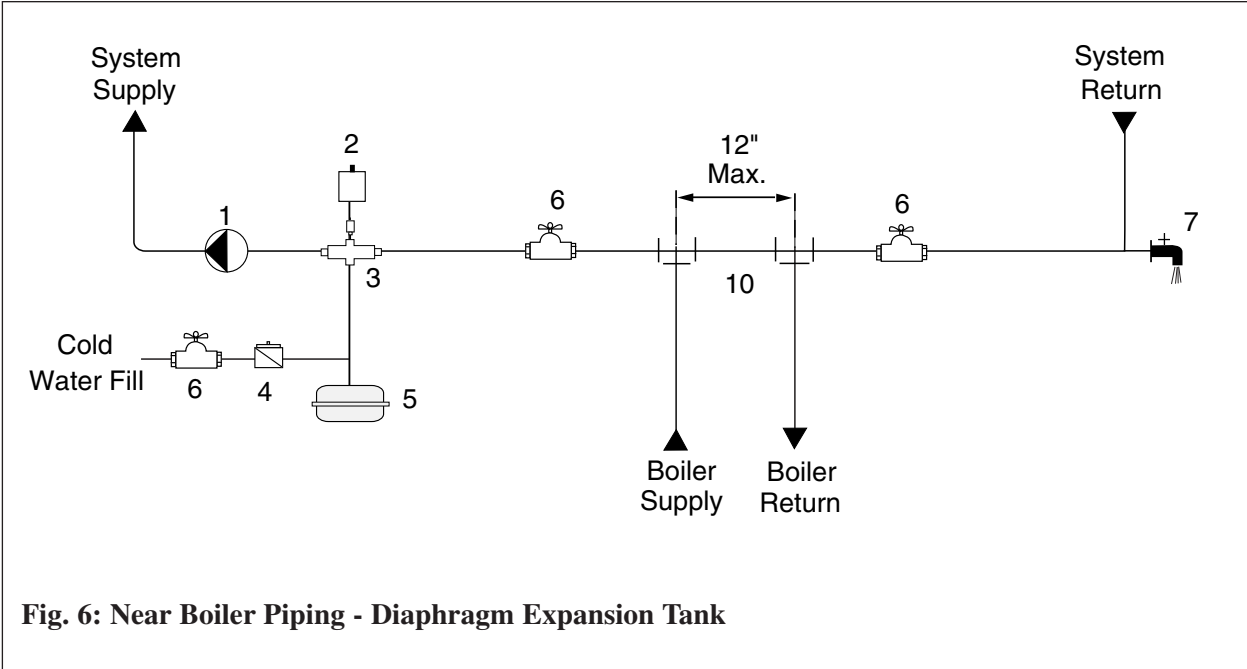

Fig. 6: Near Boiler Piping - Diaphragm Expansion Tank

- | | |
|-----------------------------|----------------------------------|
| 1. System circulator | 6. Isolation valve |
| 2. Automatic air vent | 7. Drain/purge valve |
| 3. Air separator | 8. Tank fitting |
| 4. Automatic fill valve | 9. Closed type expansion tank |
| 5. Diaphragm expansion tank | 10. Primary/secondary connection |

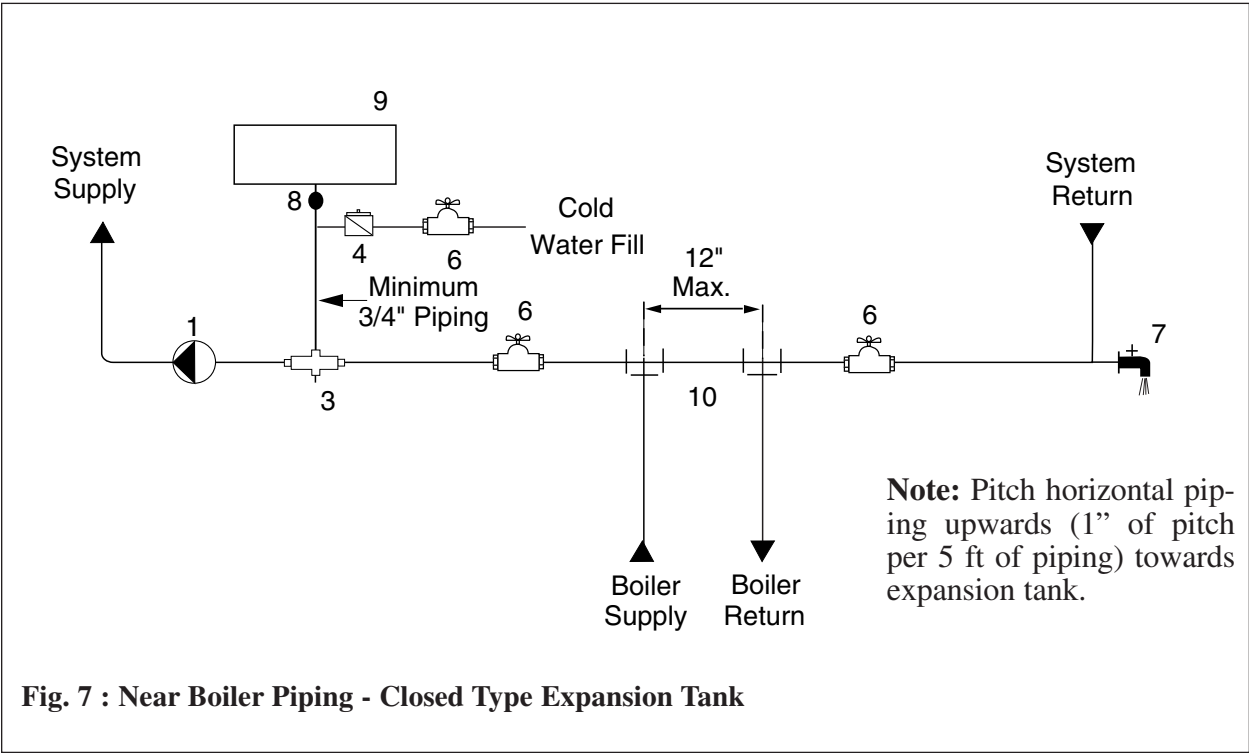

Fig. 7 : Near Boiler Piping - Closed Type Expansion Tank

- 1. System circulator
- 2. Automatic air vent
- 3. Air separator
- 4. Automatic fill valve
- 5. Diaphragm expansion tank
- 6. Isolation valve
- 7. Drain/purge valve
- 8. Tank fitting
- 9. Closed type expansion tank
- 10. Primary/secondary connection

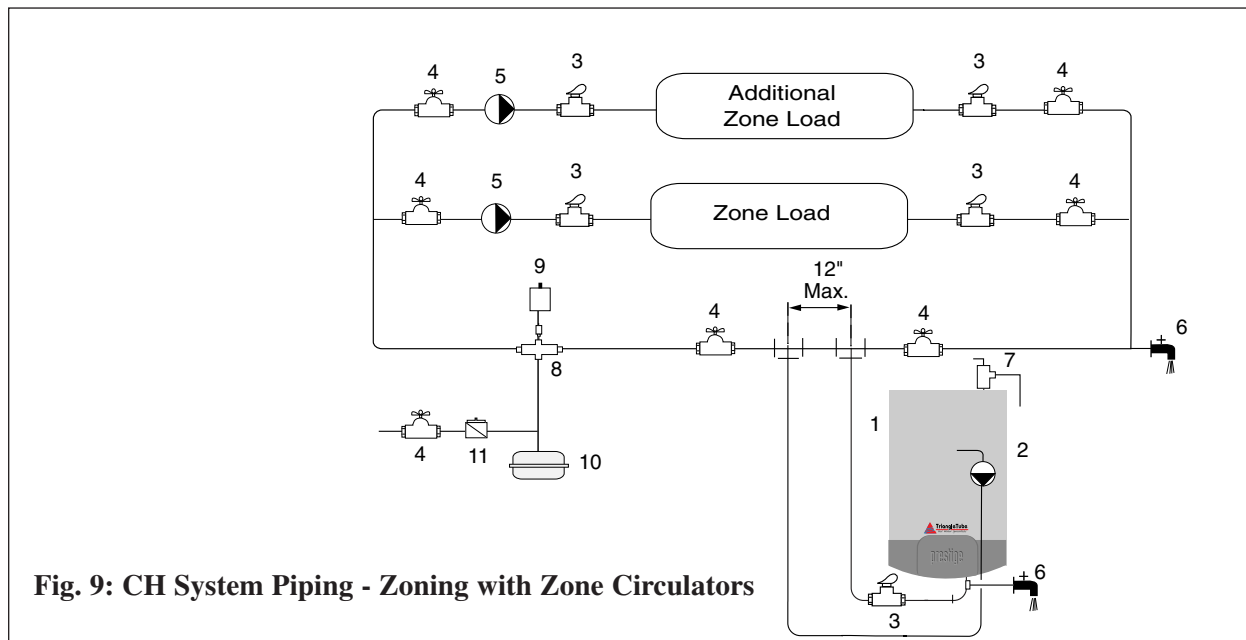

Fig. 9: CH System Piping - Zoning with Zone Circulators

- | | |
|-------------------------------|------------------------------|
| 1. PRESTIGE Excellence boiler | 7. Pressure relief valve |
| 2. CH circulator (provided) | 8. Air separator |
| 3. Flow/check valve | 9. Automatic air vent |
| 4. Isolation valve | 10. Diaphragm expansion tank |
| 5. Zone circulator | 11. Automatic fill valve |
| 6. Drain/purge valve | |

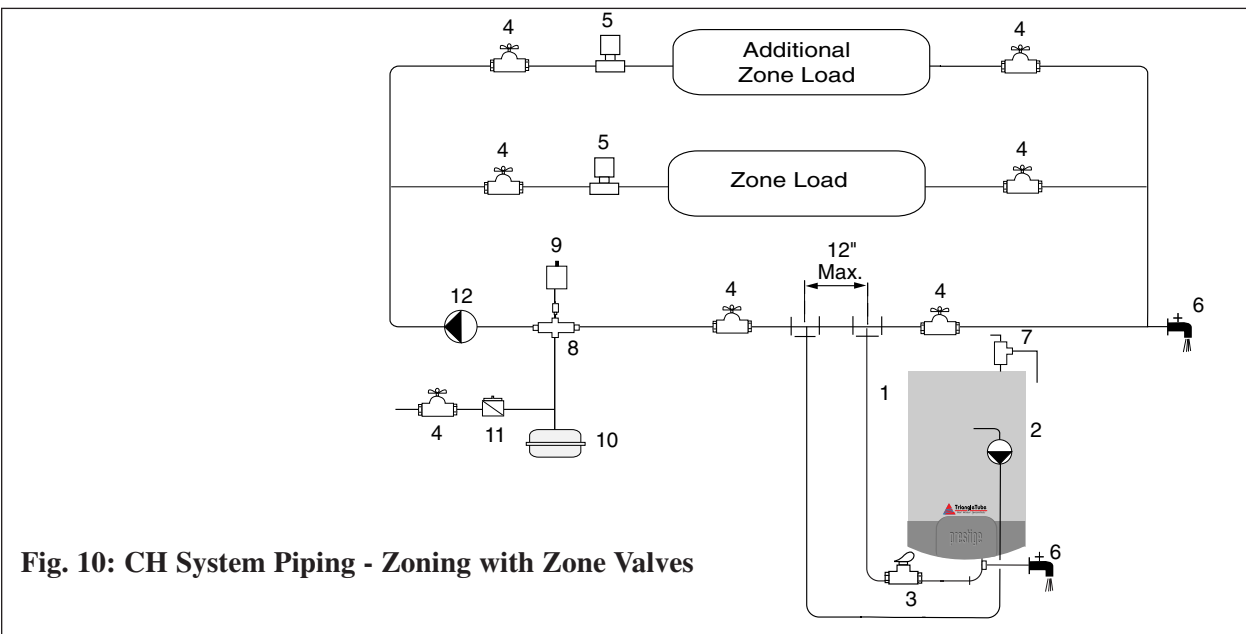
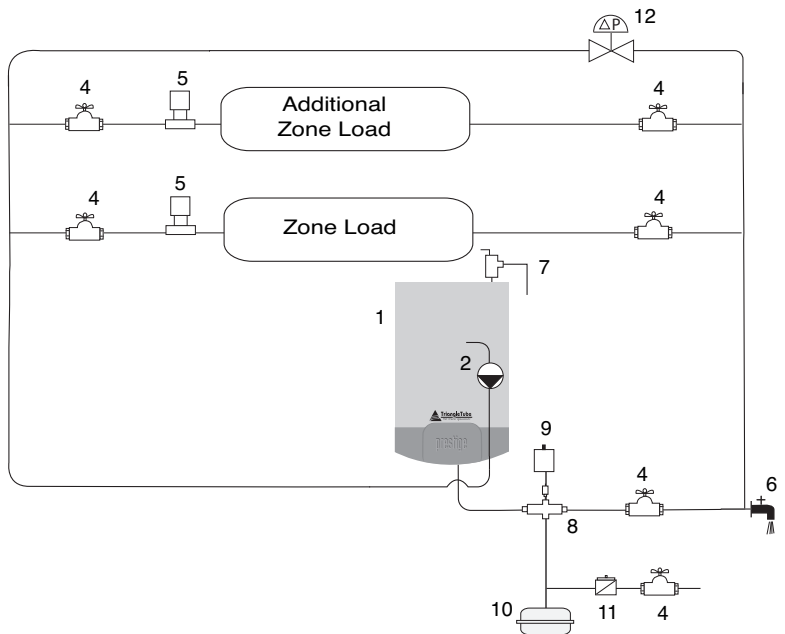

Fig. 10: CH System Piping - Zoning with Zone Valves

- | | |
|-------------------------------|------------------------------|
| 1. PRESTIGE Excellence boiler | 7. Pressure relief valve |
| 2. CH circulator (provided) | 8. Air separator |
| 3. Flow/check valve | 9. Automatic air vent |
| 4. Isolation valve | 10. Diaphragm expansion tank |
| 5. Zone valve | 11. Automatic fill valve |
| 6. Drain/purge valve | 12. System circulator |



Note: Verify CH circulator is properly sized to overcome the system pressure drop and provide adequate flow through the boiler system.

Fig. 11: CH System Piping - Multiple Zone Valve with Single System/Boiler Circulator

- | | |
|-------------------------------|---------------------------------|
| 1. PRESTIGE Excellence boiler | 8. Air separator |
| 2. CH circulator | 9. Automatic air vent |
| 4. Isolation valve | 10. Diaphragm expansion tank |
| 5. Zone valve | 11. Automatic fill valve |
| 6. Drain/purge valve | 12. Pressure differential valve |
| 7. Pressure relief valve | |

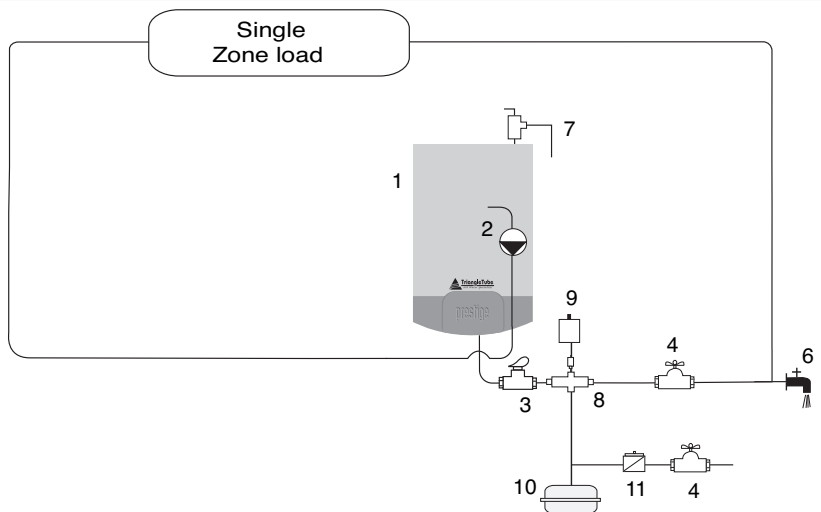

Note: Verify CH circulator is properly sized to overcome the system pressure drop and provide adequate flow through the boiler system.

Fig. 12: CH System Piping - Single Zone System with Single System/Boiler Circulator

- | | |
|-------------------------------|------------------------------|
| 1. PRESTIGE Excellence boiler | 7. Pressure relief valve |
| 2. CH circulator | 8. Air separator |
| 3. Flow check valve | 9. Automatic air vent |
| 4. Isolation valve | 10. Diaphragm expansion tank |
| 6. Drain/purge valve | 11. Automatic fill valve |

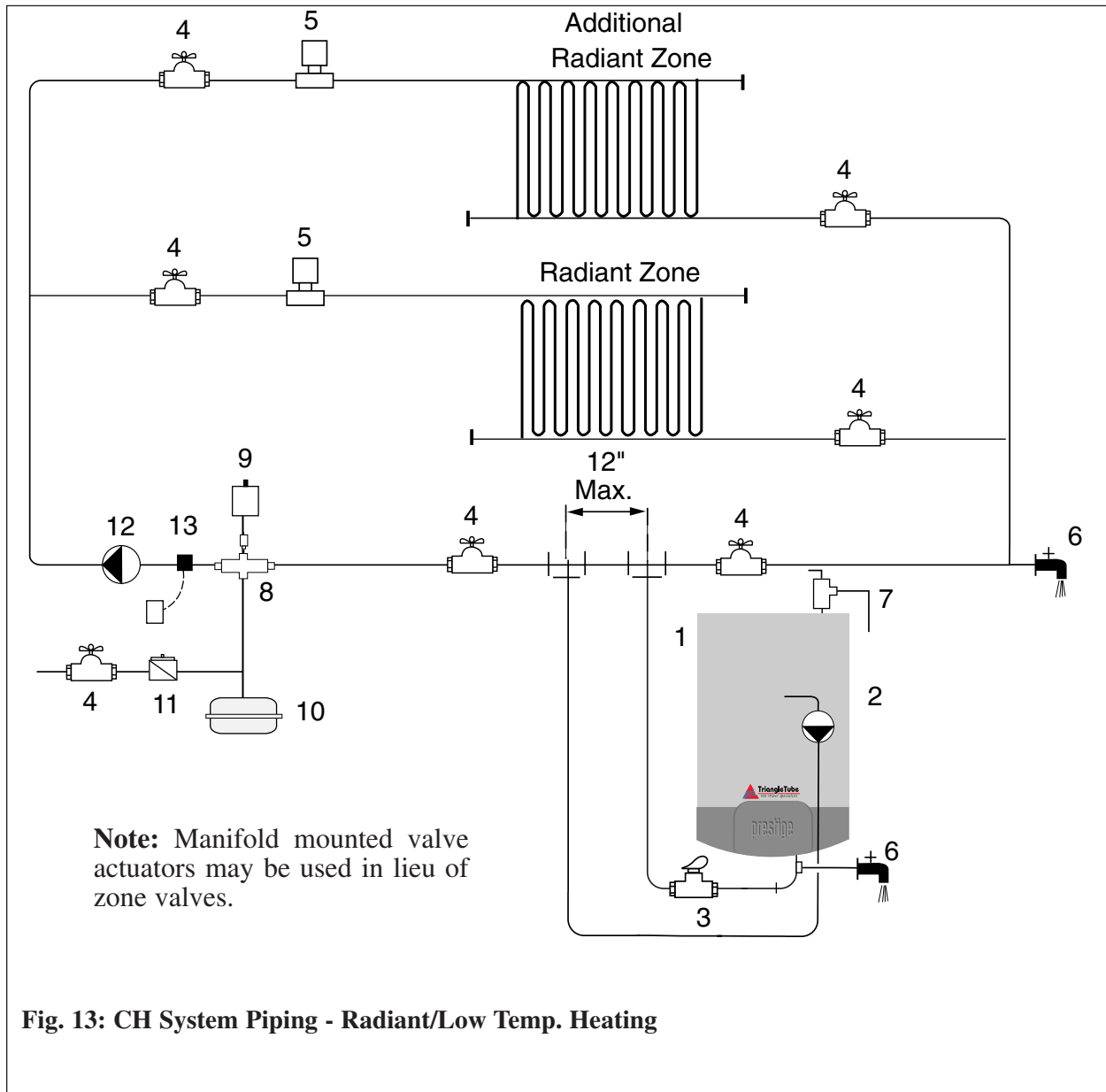
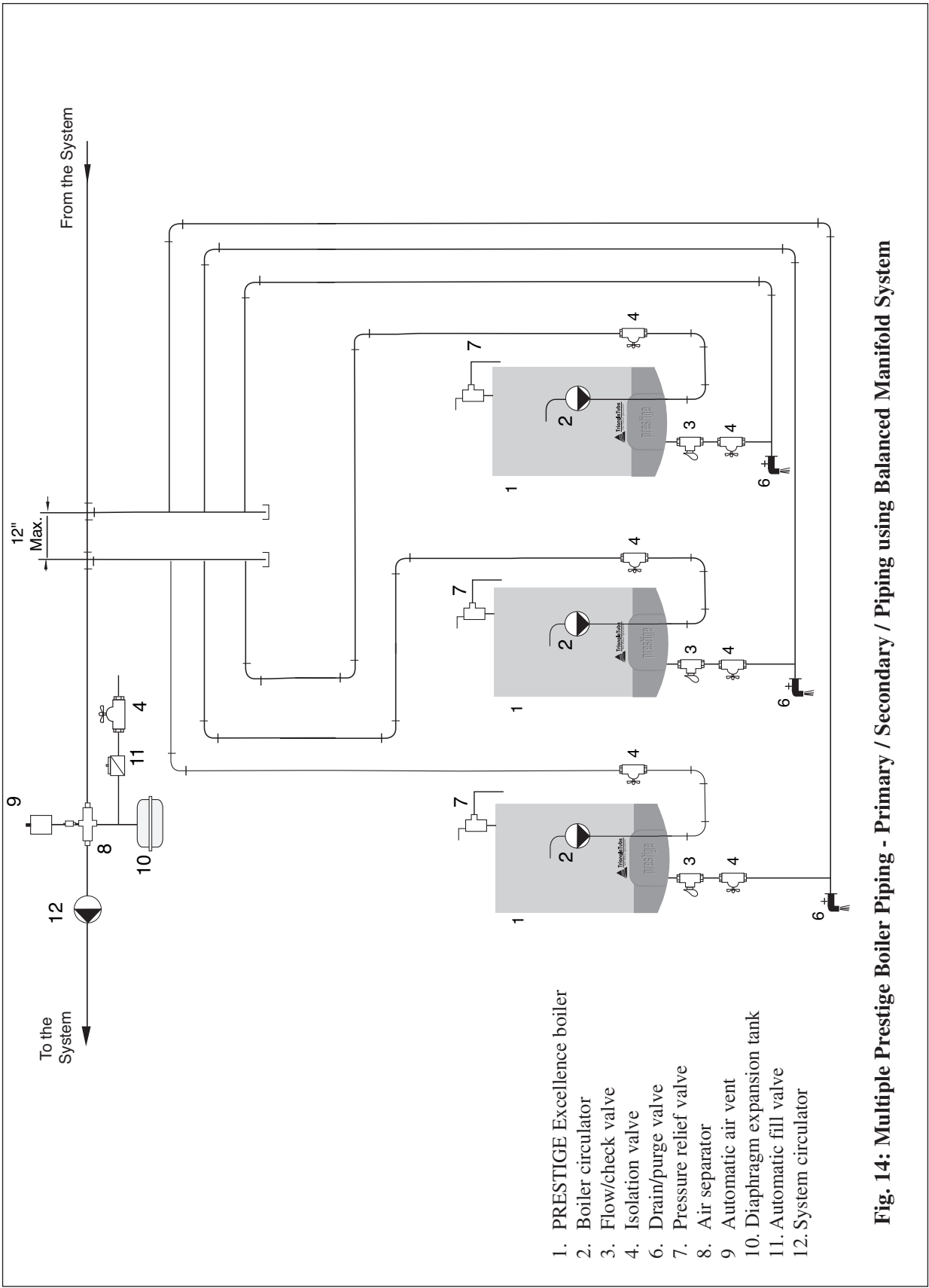

Fig. 13: CH System Piping - Radiant/Low Temp. Heating

- | | |
|-------------------------------|------------------------------------|
| 1. PRESTIGE Excellence boiler | 8. Air separator |
| 2. CH circulator (provided) | 9. Automatic air vent |
| 3. Flow/check valve | 10. Diaphragm expansion tank |
| 4. Isolation valve | 11. Automatic fill valve |
| 5. Zone valve | 12. System circulator |
| 6. Drain/purge valve | 13. High temperature limit control |
| 7. Pressure relief valve | |



- 1. PRESTIGE Excellence boiler
- 2. Boiler circulator
- 3. Flow/check valve
- 4. Isolation valve
- 6. Drain/purge valve
- 7. Pressure relief valve
- 8. Air separator
- 9. Automatic air vent
- 10. Diaphragm expansion tank
- 11. Automatic fill valve
- 12. System circulator

Fig. 14: Multiple Prestige Boiler Piping - Primary / Secondary / Piping using Balanced Manifold System

**SECTION V - Installing Vent /
Combustion Air & Condensate Drain**

Installing Vent and Combustion Air

DANGER

The PRESTIGE Excellence must be vented and supplied with combustion air as shown in the PRESTIGE Vent Supplement, included in the boiler installation envelope. Refer to optional vent kit instructions for additional vent installation instructions. Once installation is completed, inspect the vent and combustion air system thoroughly to ensure systems are airtight and comply with the instructions given in the venting supplement and are within all requirements of applicable codes. Failure to comply with the installation requirements on the venting and combustion air piping will cause severe personal injury or death.

Installing Condensate Drain Assembly

1. Locate the condensate drain assembly and install as shown in Fig. 15 page 26.

NOTICE

The installer may want to fill the condensate trap with water prior to assembling on the unit.

2. Remove the retaining nut and rubber seal from the condensate drain assembly and slide over the heat exchanger condensate drain nipple. Connect the condensate drain assembly to the retaining nut and tighten. **Hand tight only!**

WARNING

Ensure the condensate drain assembly contains the plastic seated ball. Do not install the condensate drain assembly if the ball is lost or missing, replace the entire assembly.

3. Remove the compression nut and rubber seal from the drain outlet.
4. Using 3/4" x 2' flexible PVC tube provided, slide the compression nut and rubber seal over the pipe.

NOTICE

The use of 3/4" PVC or CPVC pipe is also acceptable. If 3/4" pipe is used deburr and chamfer pipe to allow mating onto the drain assembly.

5. Thread the rubber seal into the compression nut to ease installation of the pipe to the drain assembly.
6. Seat the pipe onto the drain assembly and tighten the compression nut. **Hand tight only!**

NOTICE

The installer may opt to using 13/16" ID tubing in lieu of rigid piping.

NOTICE

The drain line materials must be an approved material by the authority having jurisdiction. In absence of such authority, PVC and CPVC piping must comply with ASTM D1785 or D2845. The cement and primer used on the piping must comply with ASME D2564 or F493. For installations in Canada, use CSA or ULC certified PVC or CPVC pipe, fittings and cement/primer.

- Continue the pipe from the drain assembly to a floor drain or condensate pump.

NOTICE

When selecting and installing a condensate pump, ensure the pump is approved for use with condensing boilers and furnaces. The pump should be equipped with an overflow switch to prevent property damage from potential condensate spillage.

CAUTION

The condensate drain must remain filled and unobstructed and allow unrestricted flow of condensate. The condensate should not be subject to conditions where freezing could occur. If the condensate is subjected to freezing or becomes obstructed, it can exit from the heat exchanger, resulting in potential water damage to the boiler and surrounding area.

- The PRESTIGE Excellence will typically produce a condensate that is considered slightly acidic with a pH content below 3.0. Install a neutralizing filter if required by authority having jurisdiction.

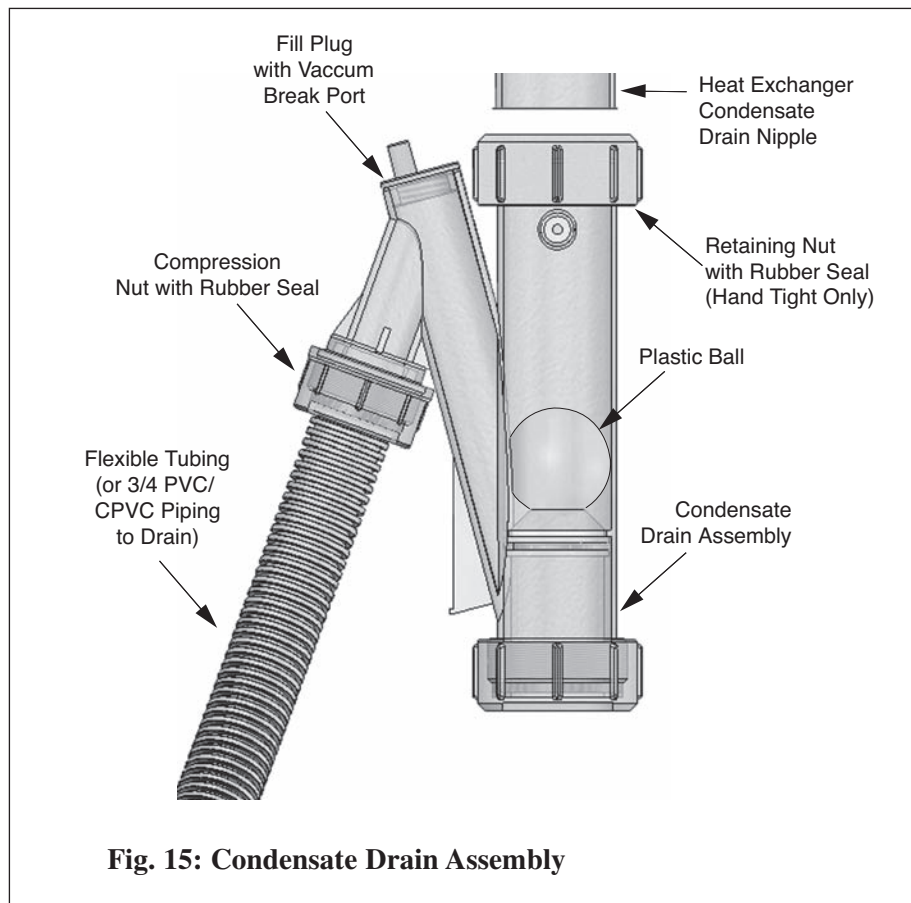

SECTION VI - Gas Piping

Gas Supply Piping Connection

The gas supply piping must be installed in accordance to all applicable local, state and national codes and utility requirements.

1. Install a 1/2" NPT pipe union at the factory supplied gas nipple, for ease of service.
2. Install a manual shutoff valve in the gas supply piping as shown in Fig. 16. For installations in Canada the installer must tag and identify the main shutoff valve.
3. Install a sediment trap (drip leg) on the gas supply line prior to connecting to the PRESTIGE Excellence gas train as shown in Fig. 16.
4. Support the gas piping using hangers. Do not support the piping by the unit or its components.
5. Purge all air from the gas supply piping.
6. Before placing the PRESTIGE Excellence into operation, check and test all connections for leaks.
 - Close the manual shutoff valve during any pressure test with less than 13" w.c..
 - Disconnect the PRESTIGE Excellence and its gas valve from the gas supply piping during any pressure test greater than 13" w.c..

WARNING

Do not check for gas leaks with an open flame. Use a gas detection device or bubble test. Failure to check for gas leaks can cause severe personal injury, death or substantial property damage.

7. Use pipe dope compatible with natural and propane gases. Apply sparingly only to the male threads of pipe joints so that pipe dope does not block gas flow.

WARNING

Failure to apply pipe dope as detailed above can result in severe personal injury, death or substantial property damage.

WARNING

Use a two-wrench method of tightening gas piping near the unit and its gas piping connection. Use one wrench to prevent the boiler gas line connection from turning and the second to tighten adjacent piping. Failure to support the boiler gas piping connection could damage the gas line components.

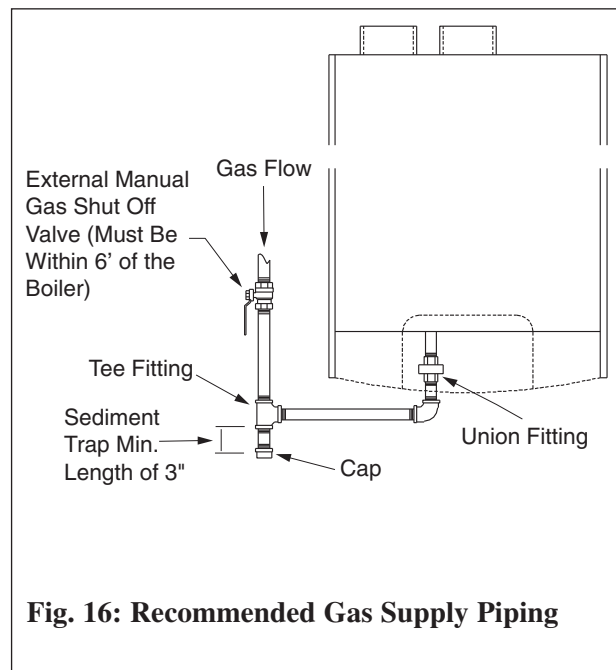

Fig. 16: Recommended Gas Supply Piping

NATURAL GAS

Pipe Sizing - Natural Gas

Refer to Table 1 for schedule 40 metallic pipe length and diameter requirements for natural gas, based on rated PRESTIGE Excellence input (divide by 1,000 to obtain cubic feet per hour).

- Table 1 is based on Natural Gas with a specific gravity of 0.60 and a pressure drop through the gas piping of 0.30”w.c..
- For additional gas piping sizing information, refer to ANSI Z223.1. For Canadian installations refer to B149.1 or B149.2.

Natural Gas Supply Pressure Requirements

1. Pressure required at the gas valve inlet supply pressure port:
 - Maximum 13”w.c. at flow or no flow conditions to the burner.

- Minimum 5”w.c. during flow conditions to the burner. Must be verified during start up and with all other gas appliances operating within the building.
2. Install 100% lockup gas pressure regulator in the gas supply line if inlet pressure can exceed 13”w.c at any time. Adjust the lock-up pressure regulator for 13”w.c maximum.

WARNING

DO NOT adjust or attempt to measure gas valve outlet pressure. The gas valve is factory-set for the correct outlet pressure. This setting is suitable for natural gas and propane and requires no field adjustment. Attempts by the installer to adjust or measure the gas valve outlet pressure could result in damage to the valve, causing potential severe personal injury, death or substantial property damage.

Table 1: Gas Piping Sizing - Natural Gas

Length of Pipe in Feet	Capacity of Schedule 40 Metallic Pipe in Cubic Feet of Natural Gas Per Hour (based on 0.60 specific gravity, 0.30" w.c. pressure drop)			
	3/4"	1"	1 1/4"	1 1/2"
SCH 40				
10	278	520	1050	1600
20	190	350	730	1100
30	152	285	590	890
40	130	245	500	760
50	115	215	440	670
75	93	175	360	545
100	79	150	305	460
150	64	120	250	380

PROPANE GAS

Pipe Sizing - Propane Gas

1. Contact the local propane gas supplier for recommended sizing of piping, tanks and 100% lockup gas regulator.

Propane Gas Supply Pressure Requirements

1. Adjust the propane supply regulator provided by the gas supplier for 13" w.c. maximum pressure
2. Pressure required at the gas valve inlet supply pressure port:
 - Maximum 13" w.c. at flow or no flow conditions to the burner
 - Minimum 5" w.c. during flow conditions to the burner. Must be verified during start up and with all other gas appliances operating within the building.

NOTICE

The propane orifice requirement for PRESTIGE Excellence is 0.204" (#52)

WARNING

DO NOT adjust or attempt to measure gas valve outlet pressure. The gas valve is factory-set for the correct outlet pressure. This setting is suitable for natural gas and propane and requires no field adjustment. Attempts by the installer to adjust or measure the gas valve outlet pressure could result in damage to the valve, causing potential severe personal injury, death or substantial property damage.

WARNING

Prior to start up, ensure the unit is set to fire propane. Check the rating label for the type of fuel. Check the gas valve for propane conversion label. If there is a conflict or doubt on the burner set up, remove the gas valve and check for the propane orifice, see Fig. 17 page 30. Failure to ensure proper burner setup could result in severe personal injury, death or substantial property damage.

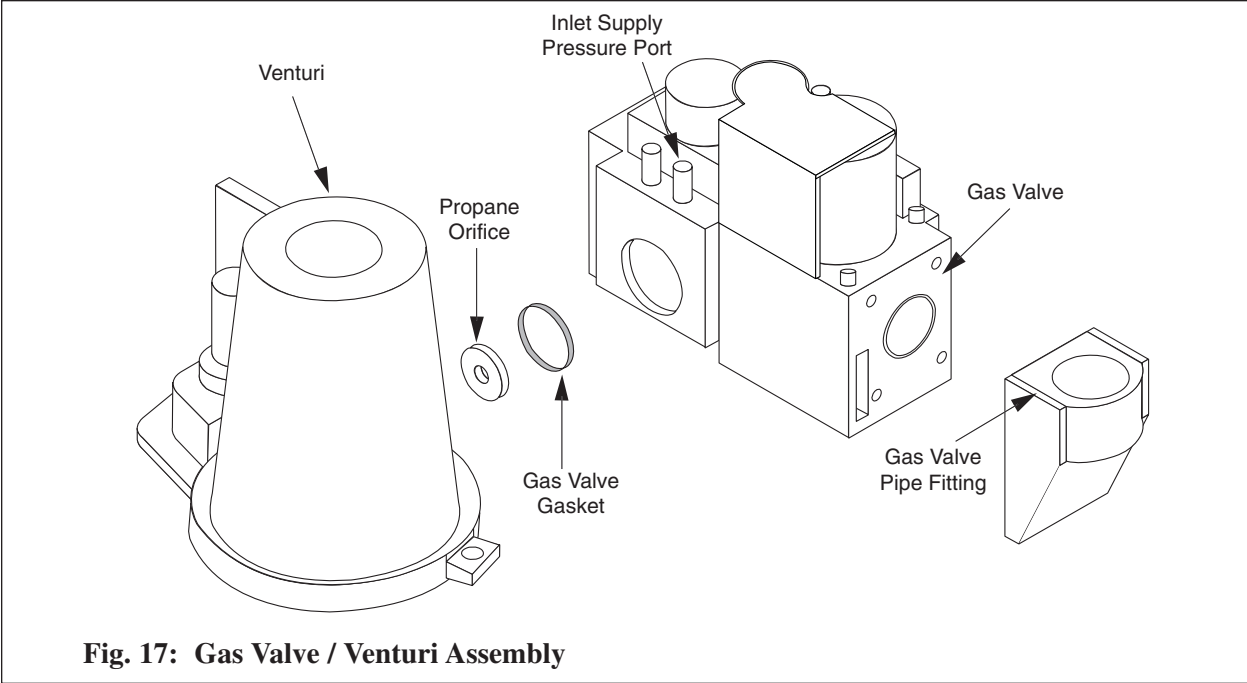

Fig. 17: Gas Valve / Venturi Assembly

SECTION VII - Internal Wiring

WARNING

ELECTRICAL SHOCK HAZARD. For your safety, disconnect electrical power supply to the unit before servicing or making any electrical connections to avoid possible electric shock hazard. Failure to do so can cause severe personal injury or death.

CAUTION

Prior to servicing, label all wires prior to disconnection. Wiring errors can cause improper and dangerous operation. Verify proper wiring and operation after servicing.

General Requirements

- Wiring must be N.E.C Class 1.
- If original wiring as supplied with the unit must be replaced, use only Type T 90°C (190°F) wire or equivalent as a minimum.
- The PRESTIGE Excellence must be electrically grounded as required by National Electrical Code ANSI/NFPA 70 - latest edition and / or the Canadian Electrical Code Part 1, CSA C22.1, Electrical Code.

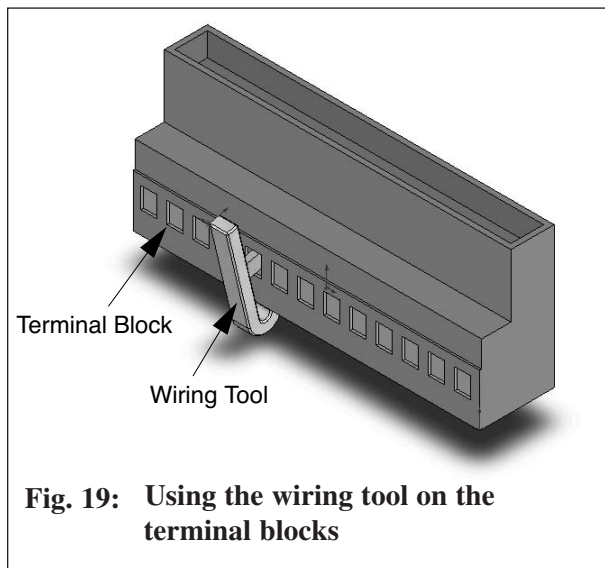

Fig. 19: Using the wiring tool on the terminal blocks

Control Module Circulator AMP Ratings

- AMP draw of the CH circulator not to exceed 2 amps

Wiring Tool Instructions

1. Locate the wiring tool on the PRESTIGE Excellence just below the the MCBA control in a plastic bag.
2. Locate the terminal blocks on the PRESTIGE Excellence below the MCBA control.

NOTICE

The 120V Terminals are located on the left set of Terminal Blocks. The 24V Terminals are located on the right set of terminal blocks.

3. Carefully pull down on the lower half of the terminal block to remove.
4. Hook the wiring tool into the desired slot of the terminal block as shown in Fig.19.
5. Push wiring tool in towards the terminal block and insert wire in slot at bottom of terminal block.
6. Repeat steps 4 & 5 until all wiring is complete.
7. Re-connect the lower half of the terminal block to the upper half.
8. Place the wiring tool back into the plastic bag or leave tool hooked to a slot on the 24V terminal block.

BEST PRACTICE

When wiring the PRESTIGE Excellence allow additional length of wire for the access panel to swing open during servicing.

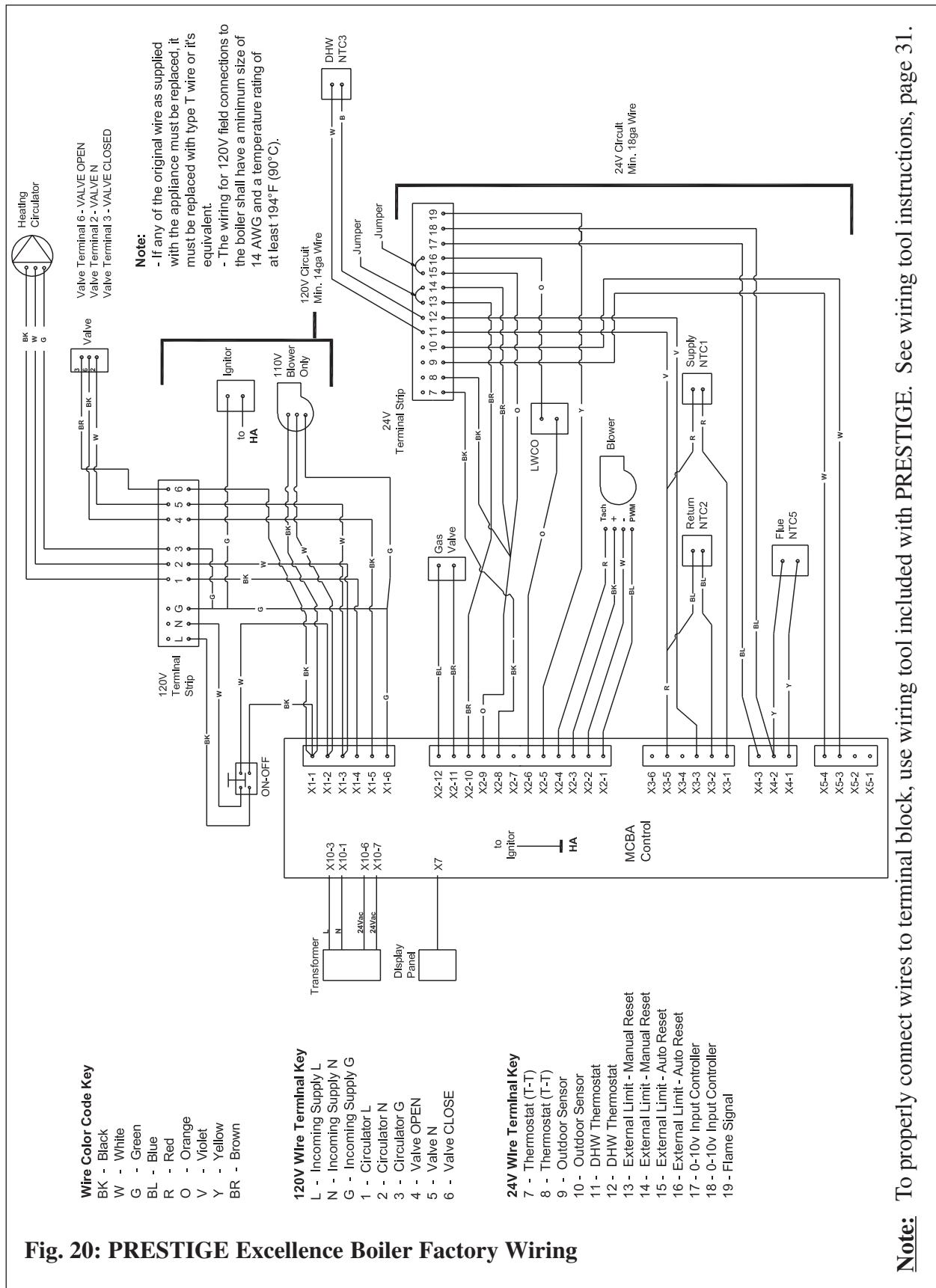

Note: To properly connect wires to terminal block, use wiring tool included with PRESTIGE. See wiring tool instructions, page 31.

SECTION VIII- External Wiring**Installation Compliance**

All field wiring made during installation must comply with:

- National Electrical Code NFPA 70 and any other national, state, provincial or local codes or requirements.
- In Canada, CSA C22.1 Canadian Electrical Code Part 1, and any other local codes.

WARNING

ELECTRICAL SHOCK HAZARD. Before making any electrical connections to the PRESTIGE Excellence, disconnect electrical power supply at the service panel. Failure to comply can cause severe personal injury or death.

Line Voltage Connections

1. Connect 120 VAC/15 amp minimum power wire to the 120V terminal strip on the wiring panel below the PRESTIGE Excellence control module, as shown in Fig. 20, page 32.
2. Route the incoming 120 VAC power wire through the provided openings in the bottom jacket panel.
3. The unit is provided with a service switch located on the front panel, check local code requirements for compliance.

NOTICE

If local electrical codes or conditions require an additional service switch, the installer must provide and install a fused disconnect or 15 amp (minimum) service switch.

Thermostat Wiring**NOTICE**

Isolate 120V wiring from 24V wiring to prevent any potential electrical “noise”.

1. Connect room thermostat or the end switch (isolated contact only) of a relay control panel to the 24V terminal strip on the wiring panel below the PRESTIGE Excellence control module, as shown in Fig. 20, page 32.
2. For proper operation install the room thermostat on an inside wall away from influences of heat and cold, i.e. water pipes, areas of draft, lighting fixtures and fireplaces.
3. Set the thermostat anticipator (if applicable) as follows:
 - Set for 0.2 amps when wired directly to the Room Thermostat.
 - Set to match the total electrical power requirements of the connected devices when wired to zone relays or other devices. Refer to the relay manufacturers’ specifications and the thermostat instructions for additional information on the anticipator setting.

NOTICE

When making low voltage connections to the PRESTIGE Excellence, ensure no external voltage is present in the thermostat circuits. If external voltage is present, provide an isolated contact to prevent damage to the boiler control.

System Circulator - Zone Valve Application

To energize the system circulator shown as item 12 in Fig. 10 page 21 reference Fig. 21. Installer to provide a Transformer / Relay such as Honeywell R8285 or equivalent and Zone Valves with isolated end switch such as Honeywell V8043 or equivalent.

NOTICE

If the installer opts for a fixed operating temperature for the boiler system, the outdoor sensor is not required and should not be installed.

Outdoor Reset Control

1. The PRESTIGE Excellence may operate with a variable boiler operating temperature using the Triangle Tube outdoor sensor, see pages 49 through 51 for installation and setup.

Additional 24V Limit Wiring

The PRESTIGE Excellence provides 24V terminal connections for additional limit controls as shown in Fig. 20 page 32. These limit terminal connections will provide a "hard" lock-out requiring a manual reset of the PRESTIGE Excellence control, or a "soft" lockout in which the PRESTIGE Excellence will automatically reset.

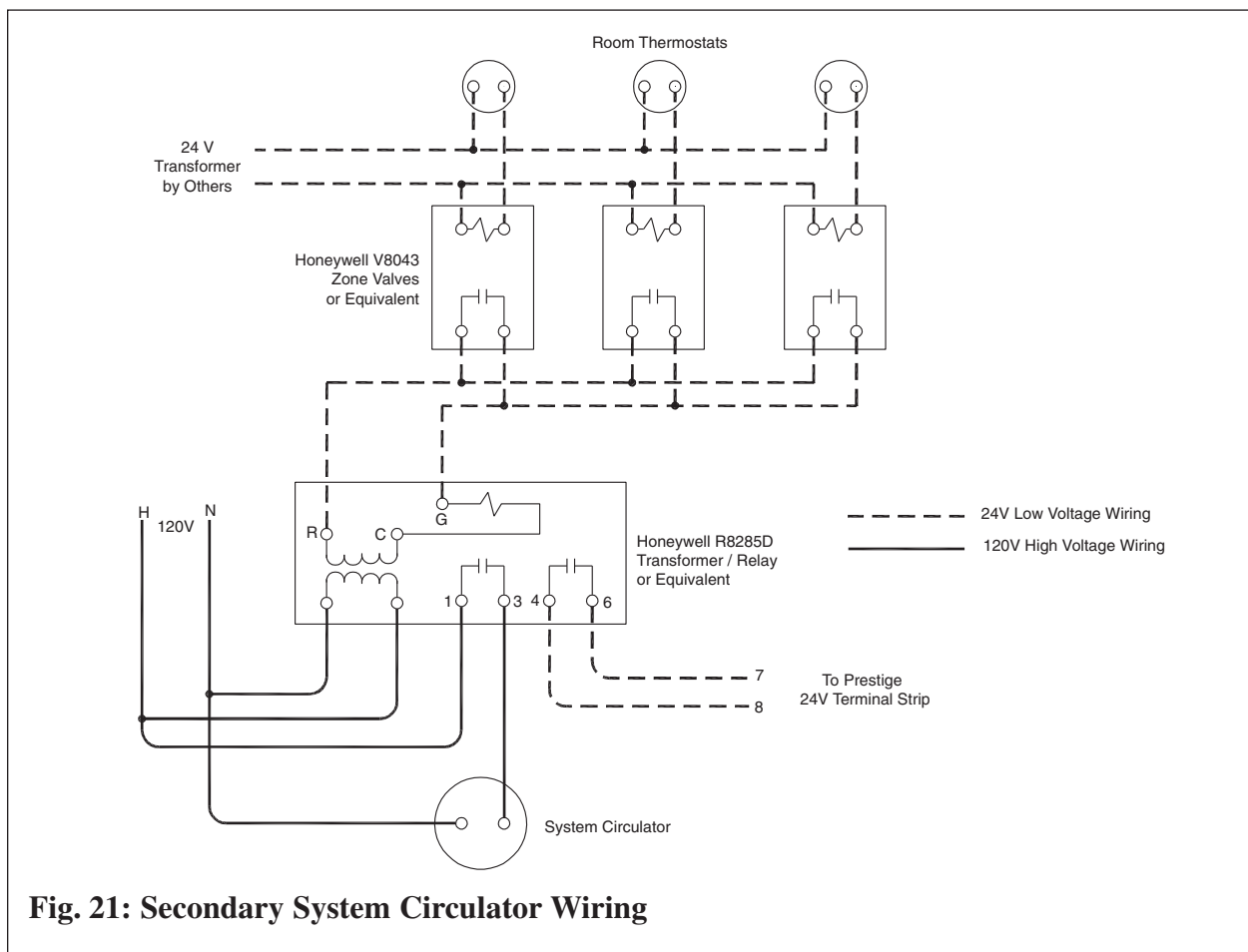
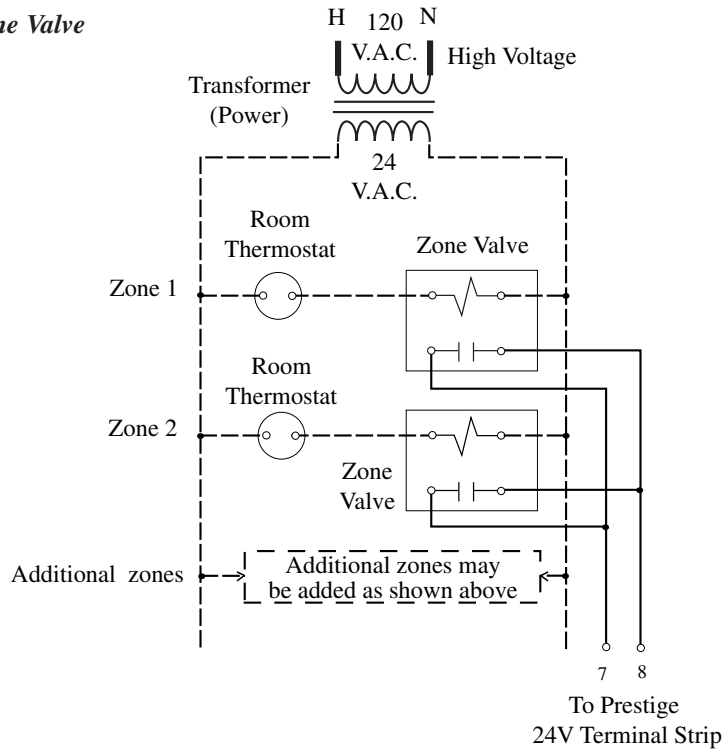

Fig. 21: Secondary System Circulator Wiring

4 Wire Zone Valve



3 Wire Zone Valve

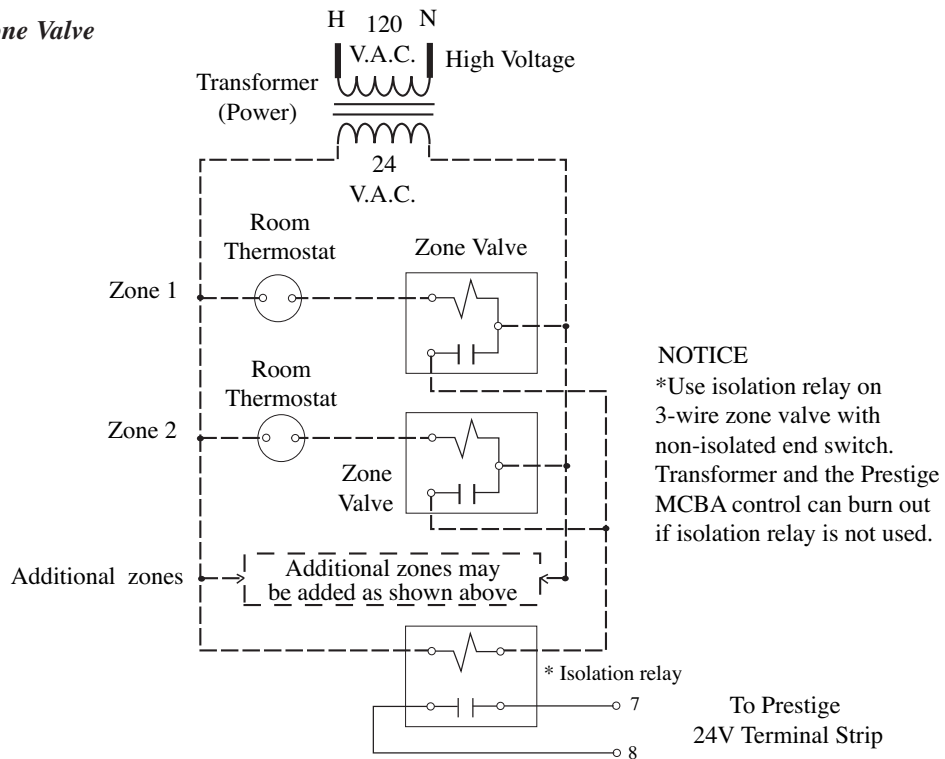

Fig. 22: Multiple Zone Field Wiring Using Zone Valves

Fig. 23: Field Wiring with Zone Circulators.

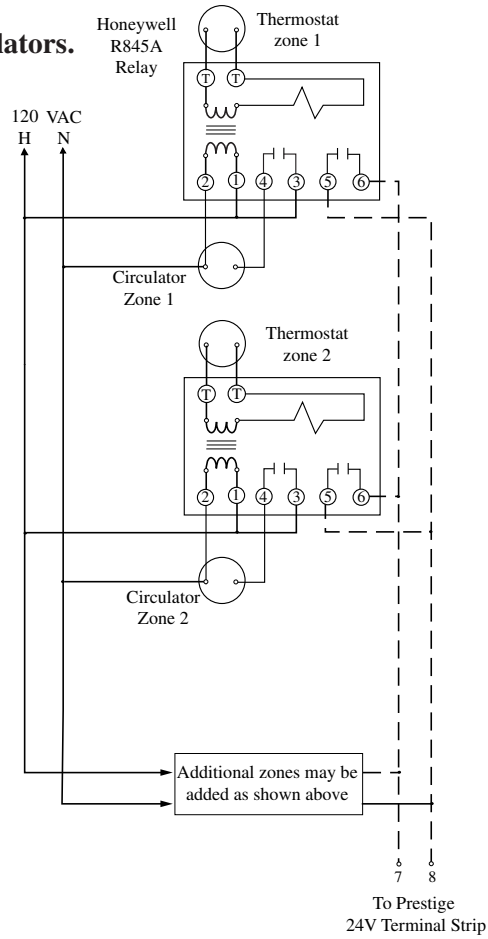
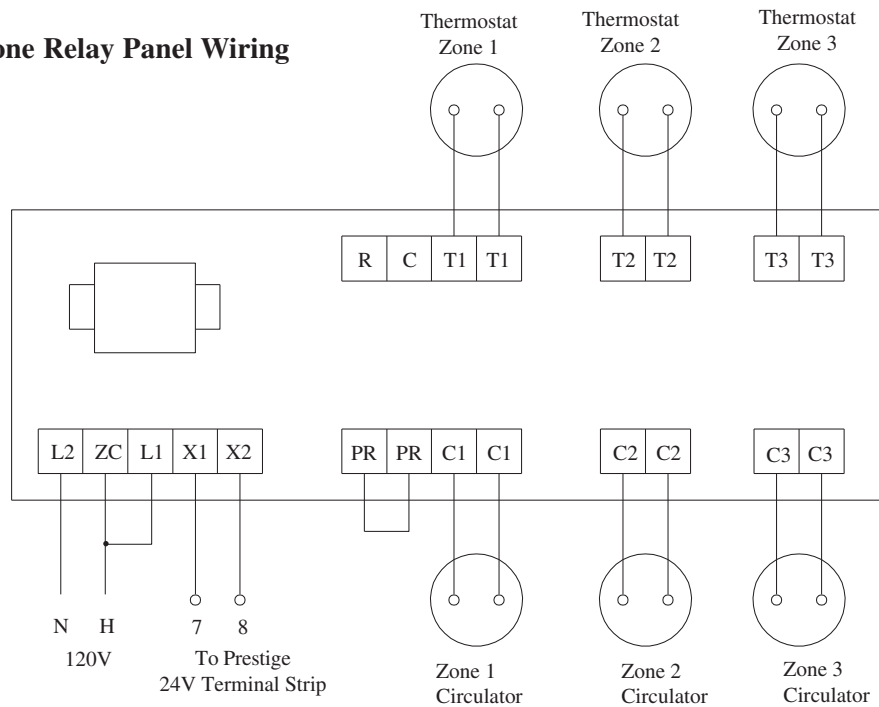

Fig. 24: Typical Zone Relay Panel Wiring



SECTION IX - Start-Up Preparation

Check Boiler System Water Chemistry

WARNING

Do not use petroleum-base cleaning or sealing compounds in the boiler system. Damage to seals and gaskets in the system components could occur, resulting in substantial property damage.

NOTICE

System water including additives must be practically non-toxic, having a toxicity rating or Class of 1, as listed in Clinical Toxicology of Commercial Products.

Water pH Level 6.0 to 8.0

Maintain the boiler water pH between 6.0 and 8.0. Check using litmus paper or contact a water treatment company for a chemical analysis.

If the pH does not meet this requirement, do not operate the PRESTIGE Excellence or leave the unit filled until the condition is corrected.

Water Hardness Less Than 7 Grains

For areas with unusually hard water (hardness above 7 grains) consult a water treatment company.

Chlorinated Water

Do not use the PRESTIGE Excellence to heat a swimming pool or spa directly.

Maintain the chlorine level of the water at levels considered safe for drinking.

Flush System to Remove Sediment

The installer must flush the boiler system to remove any sediment to allow proper operation of the PRESTIGE Excellence .

Flush the systems until the water runs clean and is free of sediment.

For boiler zoned systems, each zone should be flushed through a purge valve. Purge valves and isolation valves should be installed on each zone to allow proper flushing of the system.

Check and Test Antifreeze

For boiler systems containing antifreeze solutions, follow the antifreeze manufacturer's instructions in verifying the inhibitor level and to ensure the fluid characteristics are within specification requirements.

Due to the degradation of inhibitors over time, antifreeze fluids must be periodically replaced. Refer to the manufacturer of the antifreeze for additional instructions.

NOTICE

System water including additives must be practically non-toxic, having a toxicity rating or Class of 1, as listed in Clinical Toxicology of Commercial Products.

Use of Antifreeze in the Boiler System

WARNING

NEVER use automotive or ethylene glycol antifreeze or undiluted antifreeze in the primary system as freeze protection. This can cause severe personal injury, death or substantial property damage if ignored.

Determine the antifreeze fluid quantity using the system water content volume and following the antifreeze manufacturer instructions.

The water volume of the PRESTIGE Excellence is approximately 5 gallons (includes Boiler and DHW outer tank). Remember to include the volume of the expansion tank.

Check with local codes requirements for the installation of backflow preventers or actual disconnect from the boiler's cold water fill or make up water supply line.

NOTICE

Massachusetts Code requires a pressure reducer/backflow preventer if antifreeze is used.

Ensure the concentration of antifreeze to water does not exceed a 50/50 ratio.

NOTICE

System water, including additives, must be practically non-toxic, having a toxicity rating or Class of 1, as listed in Clinical Toxicology of Commercial Products.

CAUTION

Ensure the domestic inner tank of the PRESTIGE Excellence water heater is properly filled and pressurized prior to filling the boiler system. Reference the PRESTIGE Excellence water heater for proper guidelines on filling the inner tank. Failure to comply could result in damage of the inner tank.

Filling the Boiler System

1. Close the boiler drain valve located on the bottom of the unit and any manual or automatic air vent in the system.
2. Open all system isolation valves.
3. Fill the boiler system to correct system pressure. Correct pressure will vary with each application.

NOTICE

Typical residential system fill pressure is 12 psi. System pressure will increase when system temperature increases. Operating pressure of the system should never exceed 25 psi.

4. Purge air and sediment in each zone of the boiler system through the purge valve. Open air vents to allow air to be purged in the zones.
5. Once the system is completely filled and purged of all air and sediment, check the system pressure and check/repair any leaks.

WARNING

Unrepaired system leaks will cause continual makeup water to be added to the boiler. Continual makeup water could cause mineral buildup within the heat exchanger, reducing the heat transfer, causing possible heat buildup and eventual heat exchanger failure.

Check Low Water Cut-Off Device

- The PRESTIGE Excellence is provided with a factory installed LWCO device that measures system pressure of more than 10 psi.
- Remove the front jacket panel and check for continuity across the low water cut-off device wire terminals. The contacts should be closed when system pressure is greater than 10 psi. See item 5, on Fig. 27 page 62.

Check For Gas Leaks

WARNING

Prior to start-up and during initial operation, smell near the floor and around the unit for gas odorant or any unusual odor. Do not proceed with the start-up if there is any indication of a gas leak. Any leaks found must be repaired immediately.

WARNING

Propane installations only - The propane supplier mixes an odorant with the propane to make its presence detectable. In some cases the odorant can fade and the gas may no longer have an odor.

Prior to start-up of the unit and periodically after start-up have the propane supplier check and verify the odorant level.

Check Thermostat Circuit

- Disconnect the external thermostat wires from the 24V terminal strip on the wiring panel.
- Connect a voltmeter across the wire ends of the external thermostat wiring.
- Close each thermostat, zone valve and relay in the external circuit one zone at a time and check the voltage reading across the wire ends.

- There should **NEVER** be voltage measured at the wire ends.
- If voltage is measured at the panel under any condition, check and correct the external wiring.

NOTICE

In systems using 3-wire zone valves, backfeed of voltage to the unit is a common problem. Use an isolation relay to prevent voltage from the external circuit entering the PRESTIGE Excellence control panel.

- Reconnect the external thermostat wires to the 24V terminal strip on the wiring panel.

Inspection of Condensate Drain Assembly

1. Inspect and ensure the condensate drain assembly is properly installed as described on page 25 and shown in Fig. 15 on page 26.
2. Remove the plug from the condensate drain assembly and fill the trap with fresh water.

NOTICE

The condensate drain assembly must be filled with water when the PRESTIGE Excellence is in operation. The condensate drain assembly prevents flue gas emissions from entering the condensate line. Failure to ensure trap is filled with water could result in severe personal injury or death.

3. Re-Install plug in condensate drain assembly.

SECTION X - Start-Up Procedures**Final Checks Before Start-Up**

- Read page 45 through 48 regarding the operation of the PRESTIGE Excellence control.
- Verify the PRESTIGE Excellence and the boiler system is full of water and all system components are correctly set for operation, including the minimum flow rate through the boiler, see page 69.
- Verify Start-Up Preparation items outlined on pages 37 thru 39 have been completed.
- Verify all electrical connections are correct and securely fastened.
- Inspect vent piping and combustion air inlet piping for signs of deterioration from corrosion, physical damage or sagging. Verify combustion air piping and vent piping are intact and correctly installed and supported. Reference the PRESTIGE Vent Supplement.
- Verify burner configuration - Propane only.
 - Check for proper labeling on the gas valve and the rating label for propane configuration.
 - If there is doubt on the burner configuration, remove the gas valve and check for proper propane orifice size 0.204" (#52). Refer to Fig. 17, page 30 for location of the propane orifice.
- Ensure the Condensate Drain Assembly is filled with water.

PRESTIGE Excellence Start-Up

1. Turn the ON-OFF switch located on the front control panel to the OFF position. Turn the electrical supply or any service switch to the unit in the ON position.
2. Read and follow the Operating Instructions outlined on page 42.

If PRESTIGE Excellence Does Not Start Correctly

1. Verify DHW (parameter 2) and CH (parameter 3) Systems are turned ON or set to "01". Read the Boiler Display Standby and Parameter Section of the manual starting on page 45 for more information.
2. Check for loose electrical connections, blown fuse (external or internal to the MCBA Control) or open service switch.
3. Check continuity across the L.W.C.O device for a closed circuit. See item 5 on Fig. 27, page 62.
4. Is the external limit control (if applicable) open? Ensure the external limit is reset to the closed position.
5. Is the gas supply valve(s) open at the unit and meter?
6. Is incoming gas supply pressure at the unit more than 5" w.c. and less than 13" w.c. for natural or propane with all gas appliances operating ON or OFF
7. Are the heating thermostats set below room temperature?

If none of these conditions correct the problem, refer to the PRESTIGE Trouble-Shooting Guide or contact Triangle Tube Tech Service.

Check the PRESTIGE Excellence and System

- Check Boiler Piping.

Check Boiler system piping and components for leaks. If found, shut down the unit and repair immediately.

Purge any remaining air from the system piping. Air in the system piping will interfere with circulation creating heat distribution problems and system noise.

- Check Vent Piping and Combustion Air Piping.

Check for gas-tight seal at every connection and seam of the venting and combustion air inlet piping.

WARNING

Venting system must be sealed gas-tight to prevent flue gas spillage and potential carbon monoxide emissions, which will result in severe personal injury or death.

- Check Gas Piping
 - Check around the unit for gas odor following the procedure outlined in this manual on Page 39.

WARNING

If any gas leaks are found or suspected, shut the unit down immediately. Use a gas detection device or bubble test to locate the source of the gas leak and repair at once. Do not operate the unit until the leak is corrected. Failure to comply with this procedure could result in severe personal injury, death or substantial property damage.

- Verify Flame Pattern and Combustion
 - Check the flame pattern through the inspection port of the heat exchanger. The flame should be blue and stable. The flame should be the length of the burner head openings.

WARNING

The combustion testing and adjustments must be performed by a qualified installer, service agency or the gas supplier. All combustion measurements must be performed with calibrated equipment to ensure proper reading and accuracy.

Test for CO₂ or O₂ and for CO during high firing rate. To manually place the boiler into high fire mode, reference page 45, the combustion reading should be within the range listed in Table 2. **The CO level should not exceed 100 ppm when combustion is correct.**

WARNING

The combustion levels should be measured at high firing rate, refer to page 45 of the PRESTIGE Excellence control section on how to set the firing rate. If the combustion levels are not within the range given in Table 2 for the firing rate, shut the boiler down and contact Triangle Tube Engineering Department. Failure to comply with this requirement could result in severe personal injury, death or substantial property damage.

- Measure Input - Natural Gas Only

Table 2: Recommended Combustion Levels

	Natural Gas	Propane
O ₂ Min.	2.30%	2.70%
O ₂ Max.	5.30%	4.70%
CO ₂ Min.	8.80%	10.70%
CO ₂ Max.	10.50%	12.00%
CO Max	100 ppm	100 ppm

1. Ensure the boiler is firing at maximum firing rate. To manually place the boiler into high fire mode, reference page 45.
2. Operate the unit for approximately 10 minutes.
3. Turn off all gas appliances within the building, except the PRESTIGE Excellence.
4. At the gas meter, record the time required to use one cubic foot of gas.
5. Calculate Natural gas input using the following equation:

$$3600 \times 1000 / \text{number of second recorded for one cubic foot of gas} = \text{BTU/H.}$$
6. The BTU/H calculated should approximate the input rating listed on the unit.

FOR YOUR SAFETY READ BEFORE LIGHTING



WARNING

If you do not follow these instructions exactly, a fire or explosion may result causing property damage, personal injury or loss of life.

- A. This appliance does not have a pilot. It is equipped with an ignition device which automatically lights the burner. **DO NOT** try to light the burner by hand.
- B. **BEFORE OPERATING**, smell all around the appliance area for gas. Be sure to smell next to the floor because some gas is heavier than air and will settle on the floor.
 - Do not try to light any appliance.
 - Do not touch any electric switch; do not use any phone in your building
 - Immediately call your gas supplier from a neighbor's phone. Follow the gas supplier's instructions.
- If you cannot reach your gas supplier, call the fire department.
- C. Use only your hand to turn the external manual gas valve. Never use tools. If the valve will not turn by hand, don't try to repair it; call a qualified service technician. Force or attempted repair may result in a fire or explosion.
- D. Do not use this appliance if any part has been under water. Immediately call a qualified service technician to inspect the appliance and to replace any part of the control system and any gas control which has been under water.

WHAT TO DO IF YOU SMELL GAS

OPERATING INSTRUCTIONS

1. **STOP!** Read the safety information above. This appliance is equipped with an ignition device which automatically lights the burner. **DO NOT** try to light the burner by hand.
2. Set room thermostat(s) to lowest setting. Turn the external manual gas valve handle clockwise  "CLOSE" (valve handle shall be perpendicular to gas piping).
3. Turn the service switch on the PRESTIGE Excellence control panel OFF.
4. Remove the front jacket panel on the unit.
5. Turn the external manual gas valve handle counter clockwise  to "OPEN" gas supply (valve handle shall be parallel to gas piping).
6. Wait five (5) minutes to clear out any gas. If you then smell gas in the jacket enclosure or around the unit, **STOP!** Follow "B" in the safety information above. If you don't smell gas, go to the next step.
7. Turn the service switch on the PRESTIGE control panel "ON".
8. Set room thermostat(s) to desired setting(s).
9. The PRESTIGE Excellence control panel display will show a sequence of numbers (0,1,2,3,4,etc.) as the left digit. Sequence digit 3 or 4 indicates the boiler is firing. Sequence digit 0 means there is no call for heat (all external thermostats are satisfied).
10. If the unit will not operate with a call for heat and the system piping is not hot, follow the instructions "To Turn Off Gas to Appliance", below and call your service technician or gas supplier.
11. Replace the front jacket panel. Make sure the panel is seated firmly in place and all mounting screws are tightened.

TO TURN OFF GAS TO APPLIANCE

1. Set the room thermostat to lowest setting.
2. Turn the service switch on the PRESTIGE Excellence control panel to "OFF"
3. Turn the external manual gas valve handle clockwise  to "CLOSE".

Set Boiler CH Target Temperature

1. Press the MODE button until the display shows PARA. This is the parameter mode of the control.
2. Press the STEP button until the first digit on the display shows "4". The last three digits on the display shows the outlet water temperature setting (high limit).
3. Press the "+" or "-" button to change the setting of the outlet temperature (high limit).

NOTICE

If an outdoor sensor is used, then the setting of the Boiler CH Target temperature is the target temperature when the outdoor temperature is at or below 0°F. When the outdoor temperature is higher than 0°F the PRESTIGE Excellence control will calculate the target temperature between the minimum and maximum temperature settings.

4. Press the "STORE" button to save the setting.

Operation Verification - Space Heating

NOTICE

Digits and characters shown as [####], in the following outline, represent the control panel display. The last three digits on the display is the measured boiler water temperature and may differ from what is shown in the manual.

1. Refer to Set DHW Storage Temperature outline on page 44 and set the DHW to 68 from the factory setting of 140.
2. Set the room thermostat to the lowest setting.
3. Turn off power to the boiler, wait a few seconds and turn on power to the boiler.

4. The following displays should occur:

[~~1148~~] Self check on power up

[~~0148~~] No call for heat

NOTICE

If the water heater storage temperature is below the setpoint of Parameter 1, the boiler will operate in DHW mode until setpoint is reach. Once the DHW mode is complete, proceed to step 5.

5. Initiate a call for heat by raising the set point of the room thermostat to the highest setting. The following display should occur.

[~~5148~~] This is a fan / air flow check. The burner blower will be energized momentarily prior to the prepurge cycle.

[~~1148~~] This is the prepurge cycle. The boiler blower and the CH (Central Heating) circulator become energized. The blower has a 10 second prepurge cycle.

[~~2148~~] This is the ignition cycle. The control module will energize and open the gas valve and begin the spark for ignition.

- If the burner flame proves within 4.5 seconds, the burner will continue to fire at an ignition fan speed for approximately 10 seconds to stabilize the flame.

- If the burner flame is not proven within 4.5 seconds, the control module will repeat the ignition sequence. If the flame is not proven after 5 attempts the control will lockout and the display will show [~~E-02~~]

- To verify flame failure lockout, close the manual shut off valve on the gas supply piping to the boiler and repeat ignition sequence. When verification is completed, ensure the manual shut off valve is returned to the open position.

[3148] This is the normal operation cycle. After the flame is proven and stabilized the burner will fire at low input for approximately 1 minute. After this time period, the control module will begin to modulate the burner firing rate based on actual boiler outlet temperature and the set point temperature.

6. Allow the boiler to operate and allow the boiler outlet temperature to reach the set point temperature.

[6188] This begins the burner shutdown and post purge cycle. The CH circulator will continue to run until the room thermostat is satisfied.

7. Lower the room thermostat set point below the room temperature to end the call for heat.

[1188] This begins a post purge cycle. When the room thermostat is satisfied, the boiler will shutdown. The control module will close the gas valve and the blower will continue for 30 seconds for a post purge cycle before shutting down. If another call for heat is initiated, the boiler will remain off for an additional 30 seconds before starting a new ignition sequence.

[7188] The CH circulator will continue for a 1 minute post pump cycle. The boiler is in standby MODE waiting for a call for heat.

8. Verify the operation of the boiler by repeating the operational sequence several times.
9. Return the room thermostat to a desired setting.

Set DHW Storage Temperature

1. Press the mode button until the display shows "PARA". This is the Parameter mode of the control.
2. Press the STEP button until the first digit on the display shows "1". The last three

digits on the display shows the DHW storage temperature setting.

3. Press the "+" or "-" button to change the setting of the DHW storage temperature.

NOTICE

The DHW outlet temperature is controlled by the factory supplied mixing valve. A low DHW storage temperature will affect the overall listed DHW performance.

4. Press the "STORE" button to save the setting. Press the "MODE" button until the display shows "STBY"

Operation Verification - Domestic Hot Water

1. As outlined in the verification for space heating, repeat STEPS 2 through 4.
2. Reference Set DHW Storage Temperature outline and set the DHW to the factory setting of 140°F. A DHW call for heat should be initiated and the following display should occur.

[5188] This is a Fan/Air Flow Check. The burner blower will be energized momentarily prior to the pre-purge cycle.

[1188] The prepurge cycle. The boiler blower and CH circulator become energized and the 10 second pre-purge cycle begins.

[2188] The boiler will begin the ignition sequence. The same sequence of establishing flame, trail for ignition and attempts for ignition as described in the space heating applies for domestic hot water.

[4188] This indicates normal operation for DHW. The burner will begin modulating its input based on the length of demand by the DHW setting. The burner will not go into the low input rate for the 1 minute flame stabilization period that occurs in CH mode.

3. Lower the DHW storage temperature as outlined in Set DHW Storage Temperature to satisfy the call for heat.

[1188] The post purge cycle begins. The control module closes the gas valve and the blower continues for a 30 second post purge.

[8188] The DHW will continue for a 30 second post pump cycle. If another DHW call for heat is initiated the boiler ignition sequence will begin immediately.

[9188] Boiler is in standby MODE waiting for a CH or DHW call for heat.

4. Verify the DHW operation of the boiler by repeating the outline operation sequence several times.
5. Return the DHW storage temperature and room thermostat to the desired setting.

Boiler Control Display



Standby Mode

After the boiler is turned on, the control panel will display STANDBY mode as shown in the figure above.

This is the standard mode for the PRESTIGE Excellence. The control automatically returns to this mode after 20 minutes if no keys have been pressed on the display. Any parameters that were modified are then stored.

The first character shows (on left side of display) the current status of the boiler depending on the condition of both the boiler and the burner. The last 3 characters indicate the start temperature.

If the burner is blocked due to a “soft” lockout, the display alternates between a 9 followed by the boiler outlet temperature and a “b” with a two digit error code.

Display	Boiler function
	Internal check
	Test function: Burner on, high fire mode
	Test function: Burner on, low fire mode

TO TEMPORARILY PLACE THE BURNER INTO HIGH FIRE TEST MODE: press the MODE button until “5t6y” is displayed. Then press and hold both the MODE and “+” button simultaneously until the first digit flashes “H”.

While in the test mode:

- high limit will function
- boiler circulator will function
- domestic circulator will not function
- the test mode will time out in approximately 10 minutes

TO TEMPORARILY PLACE THE BURNER INTO LOW FIRE TEST MODE: press the MODE button until “*Stby*” is displayed. Then press and hold both the mode and “-” button simultaneously until the first digit flashes “L”.

Press and hold the “+” and “-” button simultaneously to deactivate the high or low fire test mode. While in the “*Stby*” mode,

NOTICE

If the “+” button is held in the CH system (parameter 3) will be turned OFF and the display will show “*cOFF*”. Press and hold the “+” button to turn the CH system back ON, the display will show “c” followed by CH set point temperature (parameter 4) or CH target temperature. If the “-” button is held in while in the “*Stby*” mode domestic system (parameter 2) will be turned OFF and the display will show “*dOFF*”. Press and hold “-” button to turn the domestic system back ON, the display will show “d” followed by domestic set point temperature (parameter 1)

Standby Mode Display

Display	Boiler function
0180	STANDBY, no demand for heat
1180	Fan prepurge (10 seconds) or post purge cycle
2180	Ignition sequence
3180	Burner ON for space heating (CH)
4180	Burner ON for domestic water heating (DHW)
5180	Pre-check for air flow prior to prepurge cycle
6180	Burner OFF due to reaching temperature set point
7180	Post pump cycle for primary space heating (1 minute)
8180	Post pump cycle for domestic hot water (30 seconds)
9180	Burner blocked:
b 18	Supply temperature too high (202°F) .Burner will remain OFF until outlet temperature drops below 200°F
b 19	Return temperature too high (202°F). Burner will remain OFF until temperature drops below 200°F
b 24	Return temperature is measured higher than supply temperature. Burner will remain OFF until corrected.
b 25	Supply temperature increased too quickly. Burner will remain OFF for a 10 minute period. Burner will recycle, increasing waiting period 1 minute for a max. 15 minutes
b 26	Factory supplied LWCO pressure device or external limit (terminals 15 & 16) is OPEN. Burner off for 150 seconds, auto reset.
b 28	No blower signal
b 29	Blower signal present, Burner will remain OFF until condition terminates
b 30	Temperature rise between the supply and return is more than 72°F. Burner will remain OFF for 150 seconds. Burner will recycle increasing wating period 1 minute for a max. 20 cycle.
b 33	IDWH Sensor is short-circuited
b 35	Short circuit measured across flue temperature sensor terminals. Burner OFF until corrected.
b 38	IDHW sensor is OPEN
b 40	Open circuit measured across the flue temperature sensors.
b 52	Flue temperature greater than 240°F less than 250°F. Burner off for 150 seconds
b 65	Wait for the blower to start

Setting The Boiler Parameters

Parameter mode **P P P P**

To access PARAMETER mode when the system is in STANDBY mode, press the MODE button once.





To scroll through the list of parameters, simply press the “STEP” button. To modify a parameter value, use the + or - keys. Then press “STORE” to save the value you just changed. The display flashes once to confirm the data has been stored.

To activate the parameters you changed, press MODE once more (which brings you into INFORMATION mode). However, if you do not press a key, the system returns to STANDBY mode after 20 minutes and automatically stores the changes.

Key: Display



Key: Display

Key: Display	Description of parameters
 1 1 4 0	Domestic Hot Water Setting (See Note 1)
 2 0 1	Domestic Hot Water Setup (See Note 2)
 3 0 1	Space Heating Mode (See Note 3)
 4 1 8 0	Maximum temperature in space heating (CH) mode. In applications using an outdoor sensor, this is the boiler outlet target temperature at an outdoor temperature of 0°F or below.

Note 1: This parameter is factory set to 140°F. It is important to note the control adds 46°F to this setting, therefore the actual domestic hot water setting is 140°F + 46°F = 186°F.

Note 2: This parameter should not be changed from the factory setting of “01”. The performance of the DHW will be affected and can become unreliable.

Note 3: This parameter should not be changed from the factory setting of “01”. The performance of the CH (Central/Space Heating) will be affected and can become unreliable.

Accessing Boiler Information









Information mode **I N F O**

To switch from STANDBY mode to INFORMATION mode, press MODE twice. Press STEP until the system displays the information you need. The point located behind the first position flashes to indicate that the boiler is in INFO mode.

Key: Display



Key: Display

Key: Display	Description of parameters
 1 1 8 0	Measured outlet (supply) water temperature
 2 1 6 0	Measured inlet (return) water temperature
 3 - 2 2	This parameter is not used
 4 5 5	Measured outdoor temperature (Outdoor sensor required)
 5 1 5 0	Measured flue temperature
 6 1 8 0	Calculated (target) outlet water temperature
 7 0 1	Rate of increase in the outlet water temperature °F/sec
 8 0 1	Rate of increase in the return water temperature °F/sec
 9 0 0	This parameter is not used

Error (Hard Lockout) Mode

If a system fault occurs while the boiler is running, the system goes into lockout and the display starts to flash with the first digit as an E and the next two digits give the code for this fault.

For a detailed description of the error codes, reference the PRESTIGE Troubleshooting Guide.

CAUTION

The boiler freeze protection feature is disabled during a Hard Lockout, however the CH circulator will operate and the 3-way valve will open to the CH system.

CAUTION

During a hard lockout or low water condition the boiler will not re-start without service. If the heating system is left unattended in cold weather appropriate safeguards or alarms should be installed to prevent property damage.

Display	Hard Lockout
E 00	Flame detected prior to burner startup
E 02	Failed ignition after 5 attempts
E 03	Gas valve harness not properly connected
E 04	Power supply lost after lockout occurred
E 05	Internal control failure
E 06	Internal control failure
E 07	Internal control failure
E 08	Internal control failure
E 09	Internal control failure
E 11	Internal control failure
E 12	External limit (terminals 13 & 14) control is OPEN
E 13	Internal control failure
E 14	Internal control failure
E 15	Internal control failure
E 16	Internal control failure
E 17	Internal control failure
E 18	Supply Temperature exceeds 212°F
E 19	Return temperature exceeds 212°F
E 25	Supply temperature increased too rapidly
E 28	No blower signal present
E 29	Blower signal does not reset to zero
E 31	Supply temperature sensor is short circuited
E 32	Return temperature sensor is short circuited
E 36	Supply temperature sensor is OPEN
E 37	Return temperature sensor is OPEN
E 44	Internal control failure
E 52	Flue temperature exceeds 250°F
E 60	Internal control error - failure to read parameters
E 61	Internal control failure
E 65	Inadequate power supply to the fan

SECTION XI - Outdoor Reset Control

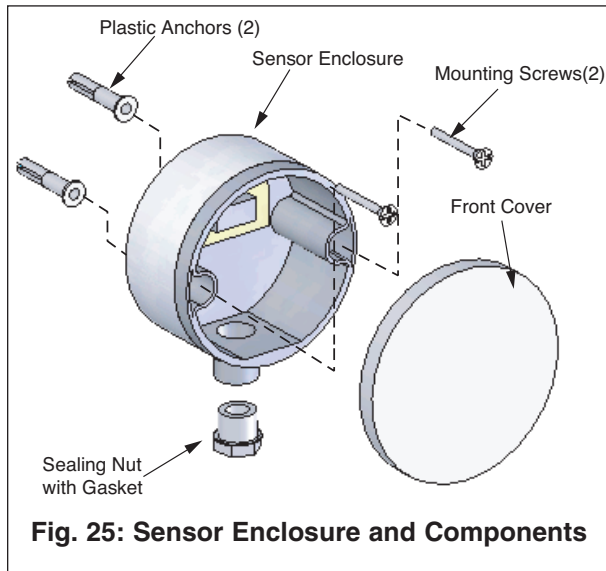

Fig. 25: Sensor Enclosure and Components

Mounting the Outdoor Sensor

1. Remove the front cover and mounting screws / anchors from the sensor enclosure.
2. When mounting the enclosure the exterior wall selected should represent the heat load of the building. Typically a northern or northeastern wall will suit most buildings. A southern facing wall for those buildings, which may have large glass walls or windows on the southern face.
3. Ensure the sensor enclosure is shielded from direct sunlight or the effects of heat or cold from other sources (exhaust fans, appliance vents...) to prevent false temperature sensing.
4. Mount the sensor enclosure at an elevation on the exterior wall to prevent accidental damage or tampering.
5. Avoid mounting the enclosure in areas subjected to excessive moisture.
6. Once an area on the exterior wall has been determined, to affix the enclosure use the enclosure as a template to mark the location of the mounting screws.
7. Using a 3/16" drill bit, drill 2 pilot holes on the marked locations.

8. Tap the enclosed plastic anchors into the pilot holes. Use care not to damage the anchors.
9. Mount the sensor enclosure using the screws provided.

Wiring the Sensor

1. Unthread the sealing nut and remove the sealing gasket from the sensor enclosure.
2. Route 18 AWG 2-wire cable or similar wire cable through the sealing nut and gasket. Connect the wire ends to the sensor terminals 1 and 2.
3. Re-insert the sealing gasket and tighten the sealing nut to the sensor enclosure.
4. Route the sensor cable back to the PRESTIGE Excellence boiler, ensuring the cable is not route parallel to telephone or power cables.

NOTICE

If the sensor cable is located in an area with sources of potential electromagnetic interference (EMI) the sensor cable should be shielded or the wires should be routed in a grounded metal conduit. If using shielded cable the shield wire should be connected to the common ground of the unit.

5. Connect the sensor wires to the outdoor sensor terminals on the 24V terminal strip located inside the boiler enclosure (see unit wiring diagram, Fig. 20 page 32).

Summer / Winter Switch at Boiler

If required the CH (Central Heating) system can be turned off at the boiler, similar to manual summer / winter switch by press/hold the “+” button while in the “STBY” mode, the display will show “cOFF”. Press/hold the “+” button to turn the CH system back on, the display will show “c” followed by CH set point temperature (Parameter 4) or CH target temperature

Boiler Target Temperature Setting

- The boiler will default to the boiler target temperature as defined in Parameter 4 when the outdoor sensor is not connected. The boiler control will modulate the firing rate to maintain this target temperature.
- The boiler will operate between the target temperature as defined in Parameter 4 and a minimum boiler temperature of 86°F.
- The boiler control will automatically detect the presence of the outdoor sensor once it is connected to the outdoor sensor terminals on the 24V terminal strip (see unit wiring diagram, Fig. 20 page 32).
- With the outdoor sensor present, the boiler target temperature will default to a temperature as defined by the outdoor air reset. As the outdoor temperature drops the boiler target temperature will increase.
- The boiler target temperature defined in Parameter 4 is the maximum boiler temperature when the outdoor air temperature is at or below 0°F.
- The boiler minimum temperature setting of 86°F will occur when the outdoor temperature is at or above 64°F.

- The boiler target temperature setpoints are based on outdoor air temperatures between 0°F and 68°F and are linearly proportional. See Graph 1 and Table 3 on page 51 for a sample setting.

Key: Display



Note: If the boiler has been operating, the display may show the current boiler status on the left digit followed by the current boiler temperature.



Pressing MODE once

Setting the Boiler Target Temperature

- Once in the PARA mode of the boiler control, scroll through the list of parameters by pressing the STEP button.

NOTICE

Parameter 4 is adjustable from 86°F to 194°F. The factory setting is 186°F. Adjusting this parameter will affect the performance of the boiler.

- Once Parameter 4 is displayed, use the + or - button to modify the parameter setting.
- Once the desired parameter setting is reached press STORE to save the value. The display will flash once to confirm the data has been saved.
- To activate the stored parameter value, press MODE twice to return to the STBY mode.

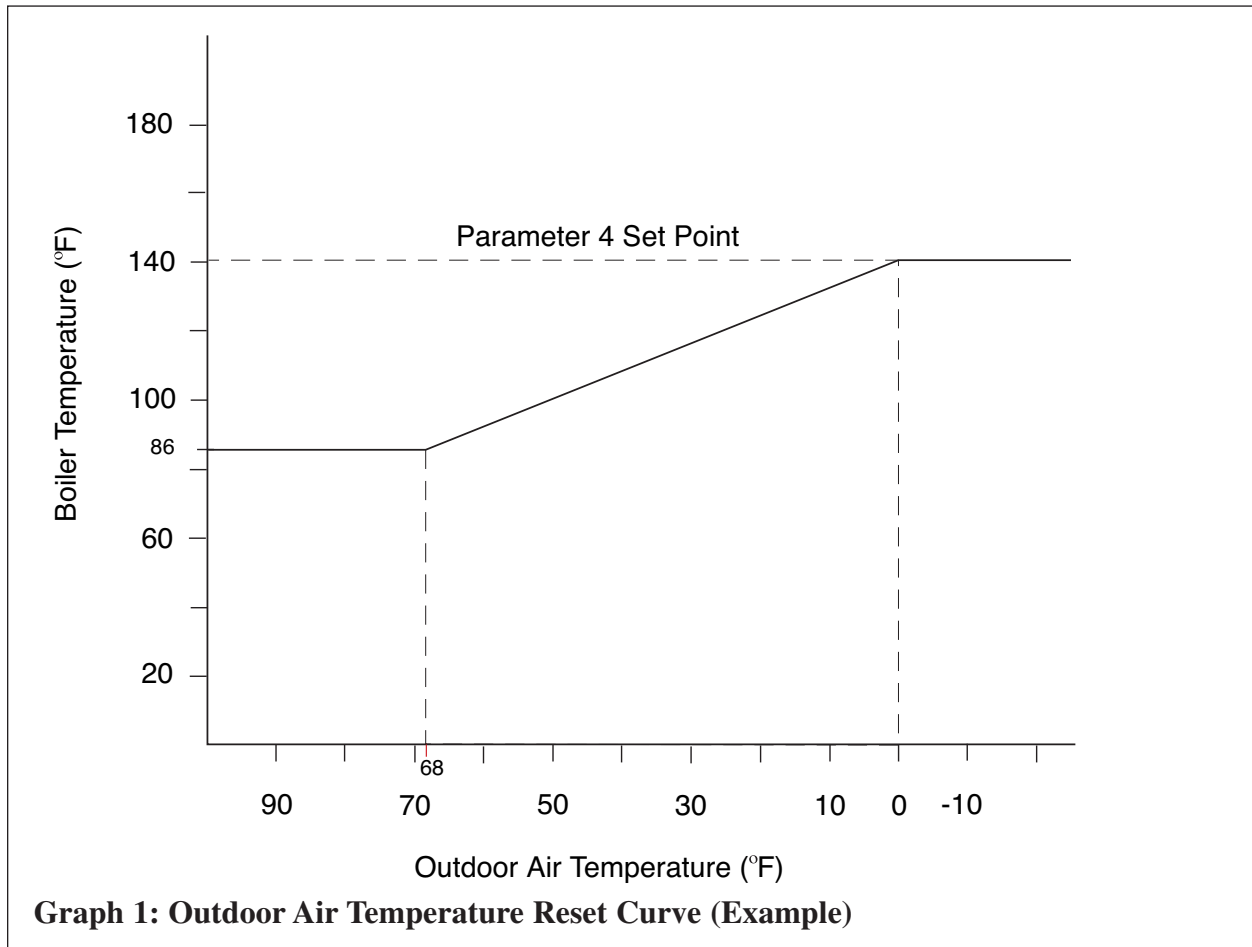

Table 3: Outdoor Air Temperature Reset (Example)

Outdoor Temperature	Boiler Target Temp. Based on Outdoor Temp.
0°F or Lower	140°F
23°F	122°F
40°F	108°F
68°F or Higher	86°F

Graph 1 illustrates Parameter 4 adjusted to 140°F target temperature at 0°F outdoor air temperature.

Note: Factory setting of Parameter 4 is 186°F.

SECTION XII- Check-Out Procedures

NOTICE

Perform the following check-out procedures as outlined and check off items as completed. When procedures are completed, the installer should complete the installation record on page 53.

Check-out Procedures

- Boiler system water chemistry checked and verified as outlined on page 37.
 - The boiler air vent and any automatic air vents placed within the system are open one full turn.
 - Air is purged from the heating zones and boiler system piping.
 - Burner has been confirmed as properly configured for Propane application, as outlined on page 29 (If applicable).
 - Thermostat circuit wiring checked and verified that no voltage is present to the low voltage terminals as outlined on page 39.
 - Operating Instructions on page 42 were followed during start-up.
 - Combustion levels and flame pattern verified as outlined on page 41.
 - Measured the rate of input on Natural Gas as outlined on page 41.
 - Checked the incoming gas pressure to the PRESTIGE to ensure a minimum pressure of 5" w.c during flow conditions to all gas appliances and a maximum pressure of 13" w.c during non-flow conditions for Natural and Propane.
 - Adjusted balancing valves and system limit controls to provide design temperatures to the primary space heating system.
 - In multiple zone applications, adjusted for correct flow of boiler water to each zone.
- Checked and verified room thermostat(s) function properly and the thermostat(s) heat anticipator (if used) was properly set.
 - Observed several operating cycles for proper operation of the PRESTIGE Excellence and the system.
 - Set the room thermostat(s) to the desired room temperature.
 - Reviewed all instructions shipped with the PRESTIGE Excellence with the homeowner or maintenance personnel.
 - Completed the Installation Record on page 53.
 - Ensure all manuals and other documentation are returned to the Installation envelope and given to the owner for safekeeping.

SECTION XIII - Installation Record

PRESTIGE Excellence Model Number: _____

Serial Number: _____

Date of Installation: _____

Fuel: Natural Gas Propane

Measured Rate of Input: _____ Btu/hr

Combustion Readings:

CO₂ _____ %

O₂ _____ %

CO _____ ppm

The following items were completed during installation:

- Installation instructions have been followed and completed
- Check-out procedures have been followed and completed
- Information regarding the unit and installation received and left with owner / maintenance personnel.

Installer Information

(Company) _____

(Address) _____

(Address) _____

(Phone Number) _____

SECTION XIV - Maintenance Schedule

Service Technician

At least on an annual basis the following maintenance should be performed by a qualified service technician:

General

- Attend to any reported problems.
- Inspect the interior of the boiler jacket area; clean and vacuum if necessary.
- Clean the condensate drain assembly and fill with fresh water.
- Check for leaks: water, gas, flue and condensate.
- Verify flue vent piping and air inlet piping are in good condition, sealed tight and properly supported.
- Check boiler water pressure, piping and expansion tank.
- Check control settings.
- Check ignition electrode (sand off any white oxide; clean and reposition).
- Check ignition wiring and ground wiring.
- Check all control wiring and connections.
- Check burner flame pattern (stable and uniform) and flame.

Additional items if combustion or performance is poor:

- Clean heat exchanger and flue ways.
- Remove burner assembly and clean burner head using compressed air only.

Once the maintenance items are completed, review the service with the owner.

Owner Maintenance

Periodically:

- Check the area around the unit.
- Check and remove any blockage from the combustion air inlet and ventilation openings.
- Check the temperature/pressure gauge.

Monthly:

- Check vent piping.
- Check combustion air inlet piping.
- Check the pressure relief valve.
- Check the condensate drain system.

Every 6 months:

- Check boiler piping and gas supply piping for corrosion or potential signs of leakage.
- Operate the pressure relief valve.

WARNING

Follow the maintenance procedures given throughout this manual. Failure to perform the service and maintenance or follow the directions in this manual could result in damage to the PRESTIGE Excellence or in system components, resulting in severe personal injury, death or substantial property damage.

SECTION XV - Maintenance Procedures

Maintenance Procedures

WARNING

The **PRESTIGE Excellence** should be inspected and serviced annually, preferably at the start of the heating season, by a qualified service technician. In addition, the maintenance and care of the unit as outlined on page 54 and further explained on pages 55 through 60 should be performed to assure maximum efficiency and reliability of the unit. Failure to service and maintain the **PRESTIGE Excellence** and the system components could result in equipment failure, causing possible severe personal injury, death or substantial property damage.

NOTICE

The following information provides detailed instruction for completing the maintenance items outline in the maintenance schedule on page 54. In addition to this maintenance, the **PRESTIGE Excellence** should be serviced at the beginning of the heating season by a qualified service technician.

Reported Problems

Any problems reported by the owner should be checked, verified and corrected before proceeding with any maintenance procedures.

Check Surrounding Area

Verify that the area surrounding the **PRESTIGE Excellence** is free of combustible / flammable materials or flammable vapors or liquids. Remove immediately if found.

Verify that combustion air inlet area is free of any contaminates. Refer to the list of potential materials listed on page 5 of this manual. If any of these products are in the area from which the unit takes its combustion air, they must be removed immediately or the combustion air intake must be relocated to another area.

Inspect Burner Area

Remove the boiler front jacket panel and venturi inlet elbow.

Vacuum any dirt or debris from the burner/blower components.

Re-install venturi inlet elbow and front jacket panel when completed.

WARNING

Do not use solvents to clean any of the burner components. The components could be damaged, resulting in unreliable or unsafe operation.

Check System Piping

Inspect all piping (water and gas) on the boiler system for leaks and verify that the piping is leak free and properly supported.

Inspect the fittings and components on the unit and verify they are leak free.

WARNING

Eliminate all boiler water system leaks. Continual fresh make-up water will reduce the heat exchanger life causing boiler failure. Leaking water may also cause severe property damage to the surrounding area. Inspect the gas supply piping using the procedure outlined on Page 41.

Clean Condensate Drain Assembly

1. Loosen the slip ring nut from the condensate drain assembly disconnecting the assembly from the boiler.
2. Empty any water from the trap and drain assembly. Flush with fresh water as necessary to clean.
3. Check the drain piping from the condensate drain assembly to the drain. Flush to clean as necessary.
4. Reassemble the condensate drain assembly onto the boiler by tightening the slip ring nut with rubber seal onto the boiler. Hand tight only.
5. Remove the fill plug on the condensate drain assembly and fill with water. See Fig. 15 on page 26.
6. Replace the fill plug on drain assembly.

Check Ventilation Air Openings

Verify that all ventilation openings to the mechanical room or building are open and unobstructed. Check the operation and wiring of any automatic ventilation dampers.

Check and verify the vent discharge and the combustion air intake are free of debris and obstructions.

Inspect Vent and Combustion Air Piping

Visually inspect the venting system and combustion air piping for blockage, deterioration or leakage. Repair any deficiencies.

Verify that the combustion air inlet piping is connected, sealed and properly supported.

WARNING

Failure to inspect the vent system and combustion air inlet piping and to have any conditions repaired, can result in severe personal injury or death.

Check Boiler System

Verify all system components are correctly installed and operating correctly.

Check the cold fill pressure for the system, typical cold water fill pressure is 12 psig.

Verify the system pressure, as the unit operates at high temperature, to ensure the pressure does not exceed 25 psig. Excessive pressure reading indicates expansion tank sizing is incorrect or system performance problems.

Inspect air vent and air separators in the system. Remove the caps on automatic air vents and briefly depress the valve stem to flush vent. Replace the cap when completed. Ensure vents do not leak, replace any leaking vents.

Check Expansion Tank

Refer to Section IV - Boiler Piping for recommended location of the expansion tank and air eliminators.

Closed -Type Tank:

- Ensure tank is partially filled with water leaving an air gap as a cushion. Refer to the manufacturer's instruction for proper fill level.
- Ensure the tank is fitted with a device that reduces gravity circulation of air-saturated tank water back into the system. This device prevents air from bubbling up through the water as it returns from the system.
- Ensure no automatic air vents are used in the system. This will allow air to escape from the system instead of returning to the tank.

Diaphragm Tank:

- Ensure the system contains a minimum of one automatic air vent. Recommended location of the air vent should be atop an air eliminator.
- Remove the tank from the system and check the charge pressure. For residential applications the charge pressure is typically 12 psig. If tank does not hold a charge pressure, then the membrane is damaged and the tank should be replaced.

Check Boiler Relief Valve

Inspect the relief valve and lift the lever to verify flow at least annually or as recommended on the warning tag of the valve.

WARNING

Before manually operating the pressure relief valve, ensure the discharge piping is directed to a suitable place of disposal to avoid a potential scald hazard. The discharge piping must be full size without restriction and installed to permit complete drainage of both the valve and line.

If after closing the valve, the valve fails to seat properly or continually weeps, replace the relief valve. Ensure the cause of the relief valve to weep is the valve itself, not due to system over-pressurization caused by an expansion tank that is waterlogged or undersized.

Inspection of Ignition Electrode

Remove the ignition electrode from the burner mounting plate.

Remove any white oxides accumulated on the electrode using fine grit sandpaper or steel wool. If the electrode does not clean to a satisfactory condition, replace the ignitor.

When replacing the ignition electrode, ensure the gasket is in good condition and correctly positioned. Replace gasket if necessary.

Check Ignition Wiring and Ground Wiring

Inspect the burner wiring from the burner control module to the ground terminal behind the control panel.

Ensure wiring is in good condition and securely connected.

Check ground continuity of the wiring to the boiler jacket or piping using a continuity meter.

Replace and correct ground wire if ground continuity is not completed and satisfactory.

Check Control Wiring

Inspect all control wiring. Ensure wiring is in good condition and properly connected.

Check Control Settings

1. Set the control display to PARAMETER mode and check all boiler settings. Adjust setting as necessary see page 47.
2. Check any external limit control settings (if used). Adjust settings as necessary.

Perform Start-Up and Checkout Procedures

Start the unit and perform the start-up procedure as listed in this manual.

Verify the cold water fill pressure is correct and the operating pressure of the boiler is within normal operating range.

Complete the checkout procedures as referenced in this manual.

Check Burner Flame

Inspect the burner flame through the observation port on the heat exchanger.

If flame pattern is not fully blue and covers the entire burner surface during high fire, shut the unit down and allow it to cool thoroughly before disassembly.

Close the external manual gas valve on the gas supply line and disconnect the gas piping and rectifier plug.

Disconnect the wiring harness connectors from the blower and remove the blower retaining screws. Remove the blower from the unit.

Remove the mounting nuts securing the burner mounting plate to the heat exchanger and set aside.

Carefully remove the burner mounting plate assembly from the heat exchanger. Ensure combustion chamber insulation is not damaged during removal of burner mounting plate assembly. See WARNING on page 60.

Remove the burner head mounting screws and remove the burner head. Inspect the burner head for deterioration. Use compressed air or a vacuum to clean the burner head.

Remove the venturi and gas valve assembly from the blower.

Use a vacuum cleaner or compressed air to clean the interior of the blower assembly. Inspect the blower blades to ensure they are clean and not damaged.

Re-assemble the venturi and gas valve onto the blower. Ensure the venturi gasket is in good condition, positioned correctly and replace gasket if necessary.

Re-assemble the burner head onto the burner mounting plate. Ensure the burner head gasket is in good condition, positioned correctly and replace gasket if necessary.

Re-assemble the burner mounting plate assembly onto the heat exchanger. Ensure the burner plate gasket and combustion chamber insulation is in place and not damaged, replace gasket and insulation if necessary. See WARNING on page 60.

Re-assemble the blower onto the burner mounting plate and reconnect the wiring harness connectors.

Re-assemble the gas supply connection and rectifier to gas valve. Open the external manual gas valve. Check gas piping for any leaks as outlined on page 41 and repair if necessary. Place the unit back into service.

Check Flame Signal

The flame signal should be a min. 3μ A –DC.

Check the ignitor for fouling or damaged insulation if a low flame signal is read.

Check ground wiring and continuity as a cause for low flame signal. Replace ignitor if conditions are satisfactory.

Check Combustion Levels

Refer to page 41 of this manual for measuring combustion levels and burner adjustments.

Check Flue Gas Temperature

1. Adjust the boiler to fire at HIGH fire, see page 45. Place the control display to INFORMATION mode, see page 47 for procedures.
2. The flue gas temperature is indicated on the display when the first digit is 5. The measured temperature (shown as the last 3 digits) should not be more than 54°F higher than the measured supply water temperature.
3. The measured supply water temperature is indicated on the information display when the first digit is 1 and the temperature shown as the last 3 digits.
4. If the measured flue gas temperature is higher than 54°F over the supply water temperature, shut the boiler down and follow the procedures listed below to clean the heat exchanger.

Clean Heat Exchanger

1. Shut down the boiler:
 - Follow the instructions on Page 42 "To Turn Off Gas to Appliance"
 - Do not drain the boiler unless the boiler will be subject to freezing conditions.
 - Do not drain the boiler if freeze protection fluid is used in the system.

2. Allow the boiler to cool down to room temperature before servicing.
3. Disconnect the gas piping and rectifier plug to the gas valve.
4. Disconnect the wiring harness connectors from the blower and remove the blower retaining screws. Remove the blower from the unit.
5. Remove the mounting nuts securing the burner mounting plate to the heat exchanger and set aside.
6. Carefully remove the burner mounting plate assembly from the heat exchanger. Ensure combustion chamber insulation is not damaged during removal of burner mounting plate assembly. See WARNING on page 60.
7. Carefully remove the combustion chamber insulation from the heat exchanger and set aside. See WARNING on page 60.
8. Use a vacuum cleaner, compressed air or water to remove any accumulation from the heat exchanger flue ways. Do not use any solvent.
9. Re-install the combustion chamber insulation onto the heat exchanger.
10. Re-assemble the burner mounting plate assembly onto the heat exchanger. Ensure the burner plate gasket and combustion chamber insulation is in place and not damaged, replace gasket and insulation if necessary. See WARNING on page 60.
11. Re-assemble the blower onto the burner mounting plate and reconnect the wiring harness connectors.
12. Reconnect the gas piping and rectifier to gas valve. Check for gas leaks, repair if necessary.
13. Close isolation valves on the boiler water piping to isolate the boiler from the heating system.

14. Attach a hose to the boiler drain valve and flush the boiler thoroughly with fresh water by using the purge valves to allow water to enter through the make-up water line to the boiler.
15. Once the boiler has been completely flushed, return the boiler and system piping back to operation.
16. Perform the required startup and checkout procedures as outlined on pages 37 to 52.

Review With Owner

Ensure the owner understands the importance to perform the maintenance schedule specified in this manual.

Remind the owner of the importance to call a licensed contractor should the unit or system exhibit any unusual behavior.

Handling of Previously Fired Combustion Chamber Insulation

WARNING

The combustion chamber insulation contains ceramic fibers, which are classified as a possible human carcinogen. When exposed to extremely high temperatures, the ceramic fibers, which contain crystalline silica, can be converted into cristobalite.

Avoid Breathing and Contact with Skin and Eyes

When removing or repairing the combustion chamber insulation follow these precaution measures:

1. Use a NIOSH approved respirator which meets OSHA requirements for cristobalite dust, similar to N95. Contact NIOSH at 1-800-356-4676 or on the web at www.cdc.gov/niosh for latest recommendations.

2. Wear long sleeved, loose fitting clothing, gloves and eyes protection.
3. Assure adequate ventilation.
4. Wash with soap and water after contact.
5. Wash potentially contaminated clothes separately from other laundry and rinse washing machine thoroughly.
6. Discard used insulation in an air tight plastic bag.

NIOSH Stated First Aid:

Eye/Skin: Immediately irrigate
Breathing: Clean fresh air

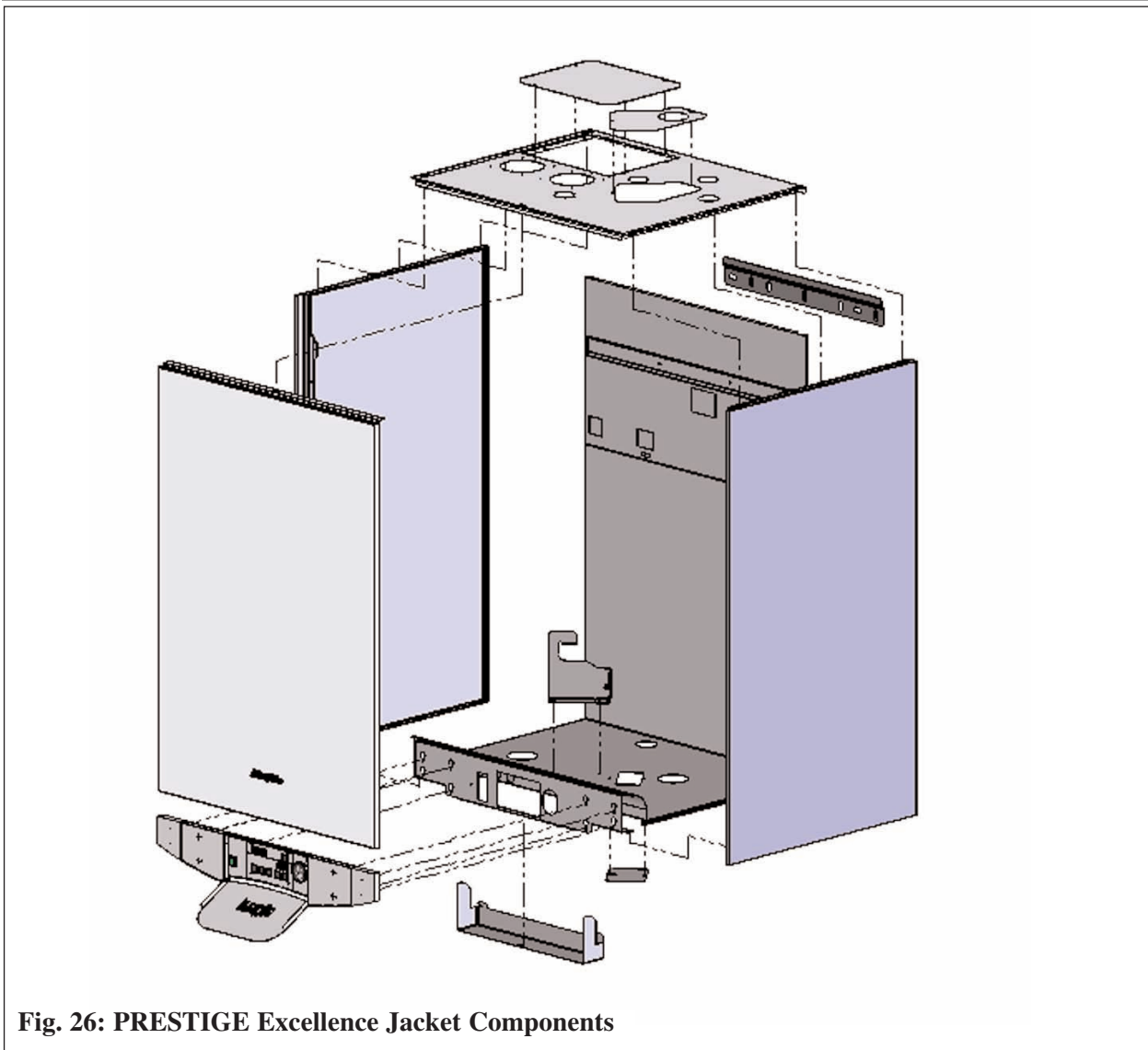

Fig. 26: PRESTIGE Excellence Jacket Components

Item	Part No.	Description
1	PSCS01	Display/Control Panel
1A	PSCS02	Display/Control Panel Extension (Not Shown)
2	PSJKT04B	Base Panel
3	PSJKT02F	Front Jacket Panel
4	PSJKT03R	Rear Jacket Panel
5	PSJKT03S	Side Jacket Panel (Left and Right)
6	PSJKT07T	Top Jacket Panel
7	PSJKT08T	Top Jacket Panel - Blower Access
8	PSJKT09T	Top Jacket Panel - IDWH Access
9	PSJKT04	Control Cover Panel
10	PSRKIT21	Wall Mounting Bracket with Hardware

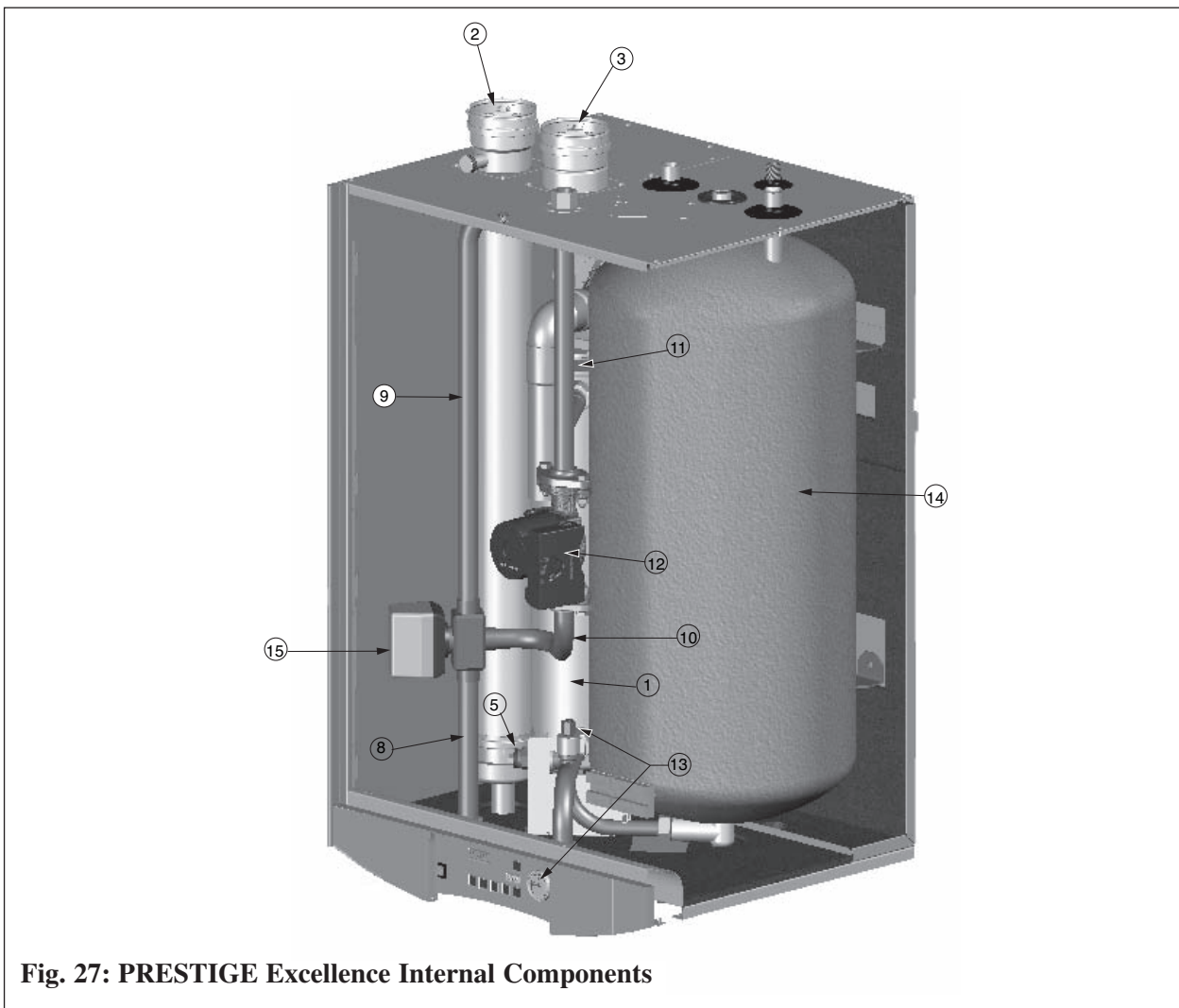

Fig. 27: PRESTIGE Excellence Internal Components

Item	Part No.	Description
1	PSRKIT01	Heat Exchanger Body
2	PSRKIT02	Vent Outlet Adapter
3	PSRKIT03	Combustion Air Inlet Adapter
4	PSRKIT04	NTC Sensor (NTC1, NTC2 and NTC5) (Not shown)
5	PGRKIT20	LWCO Pressure Device
6	PSRKIT05	Condensate Drain Assembly (Not shown)
7	PSRKIT51	Boiler Piping - Return Assembly
8	PSRKIT52	Boiler Piping - Supply Outlet Assembly
9	PSRKIT53	Boiler Piping - Supply Long Assembly
10	PSRKIT54	Boiler Piping - Supply Short Assembly
11	PSRKIT55	Boiler Piping - Relief Valve Assembly
12	HMVCIR02	Circulator
13	PSRKIT17	Pressure Gauge and Fitting
14	PSRKIT56	Excellence Water Heater Tank
15	PSRKIT57	Valve Actuator

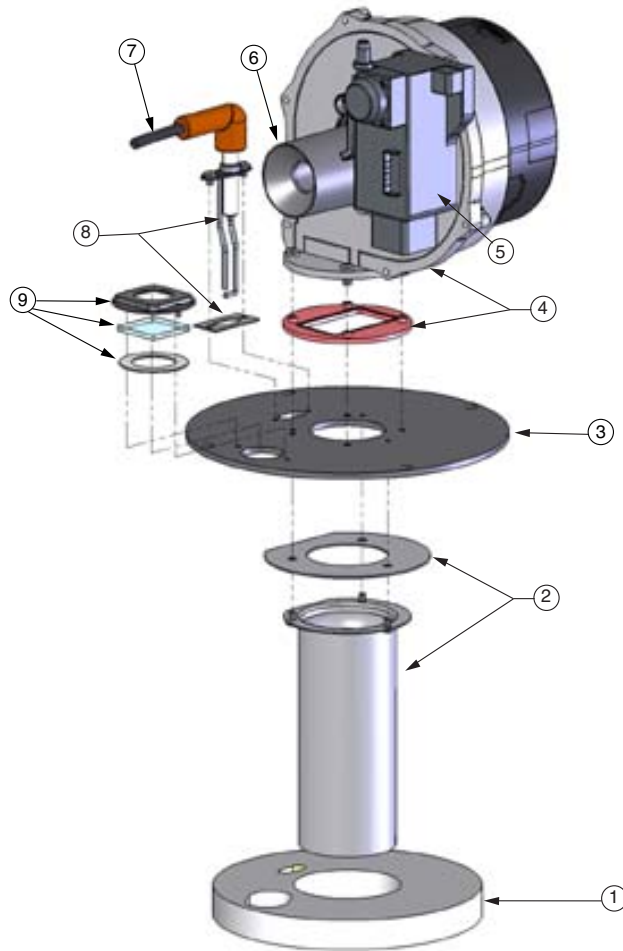

Fig. 28: PRESTIGE Excellence Burner Components

Item	Part No.	Description
1	PSRKIT09	Combustion Chamber Insulation
2	PSRKIT10	Burner Head with Gasket - Natural
	PSRKIT11	Burner Head with Gasket - Propane
3	PSRKIT12	Burner Plate
4	PSRKIT13	Blower with Gasket
5	PGRKIT01	Gas Valve
6	--	Venturi -001
7	PSRKIT14	Ignition Cable
8	PSRKIT15	Igniter with Gasket
9	PSRKIT16	Sight Glass Assembly (Glass, Gasket and Bracket)
10	--	Propane Orifice 0.204" (#52) - Not Shown
11	--	Burner Plate Gasket - Not Shown
12	PGRKIT15	Gas Valve Rectifier Plug - Not Shown

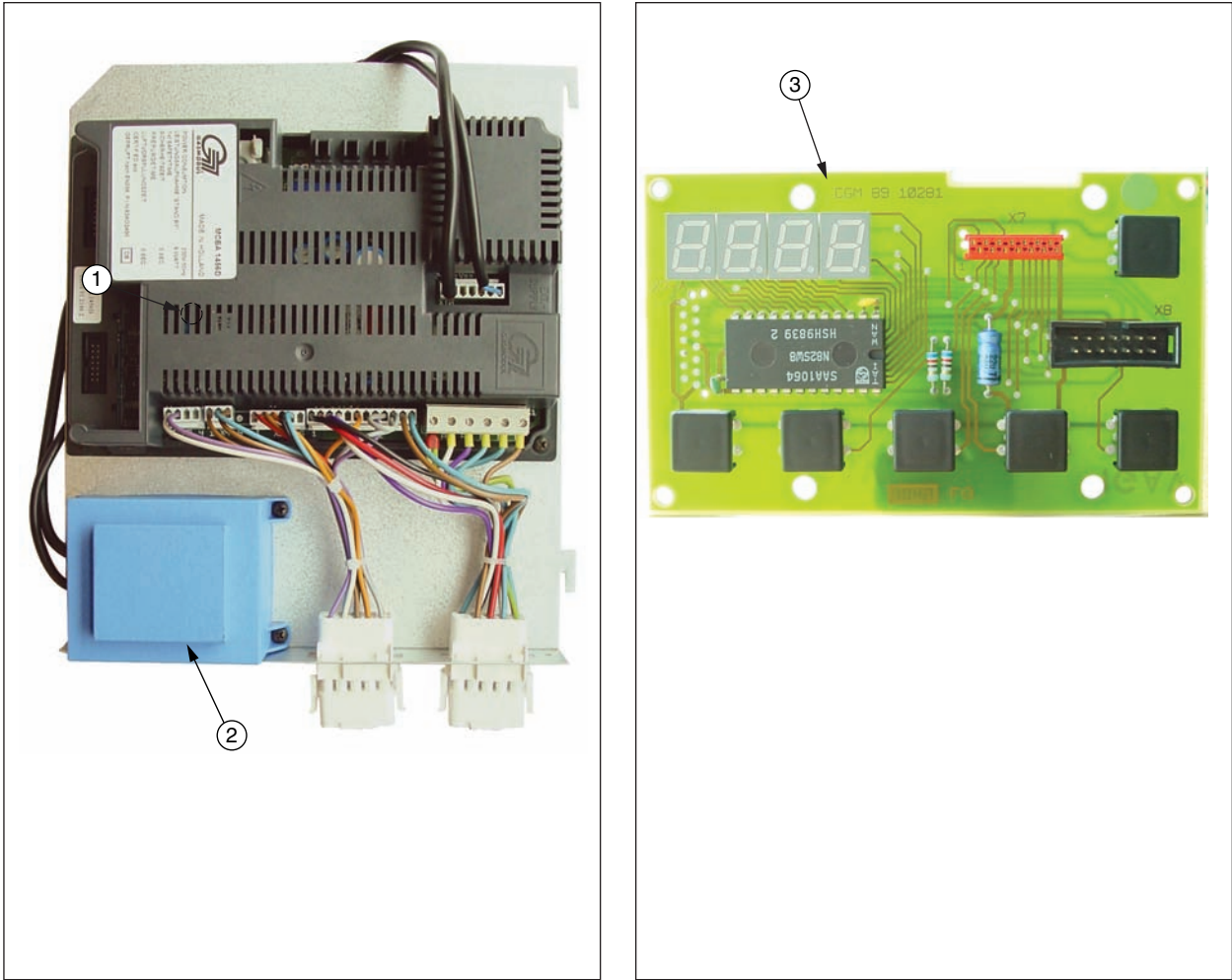
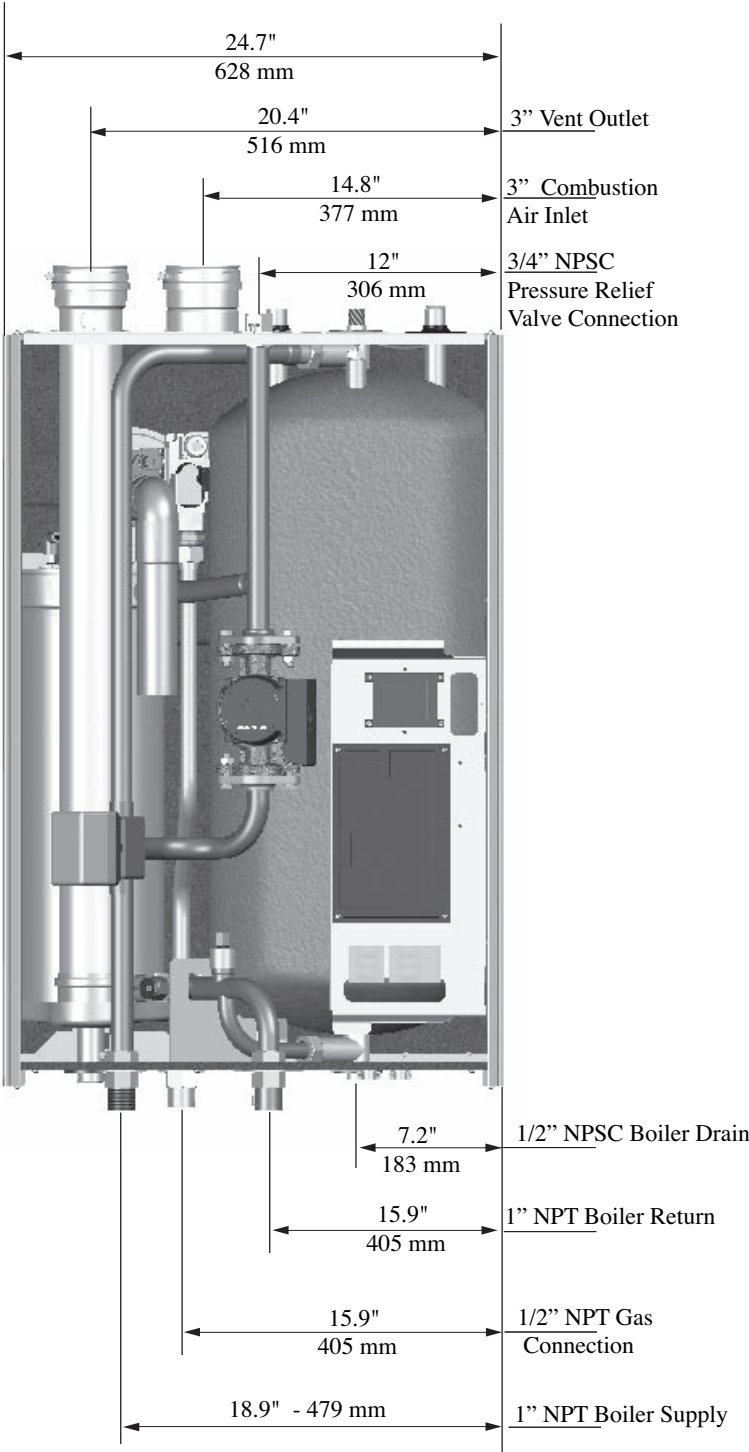

Fig. 29: PRESTIGE Excellence Electronic Components

Item	Part No.	Description
1	PSRKIT58	Prestige Control Module
2	PSRKIT19	Transformer with Surge Protection
3	PSRKIT20	Prestige Control Module Display

Product Specifications



Front View

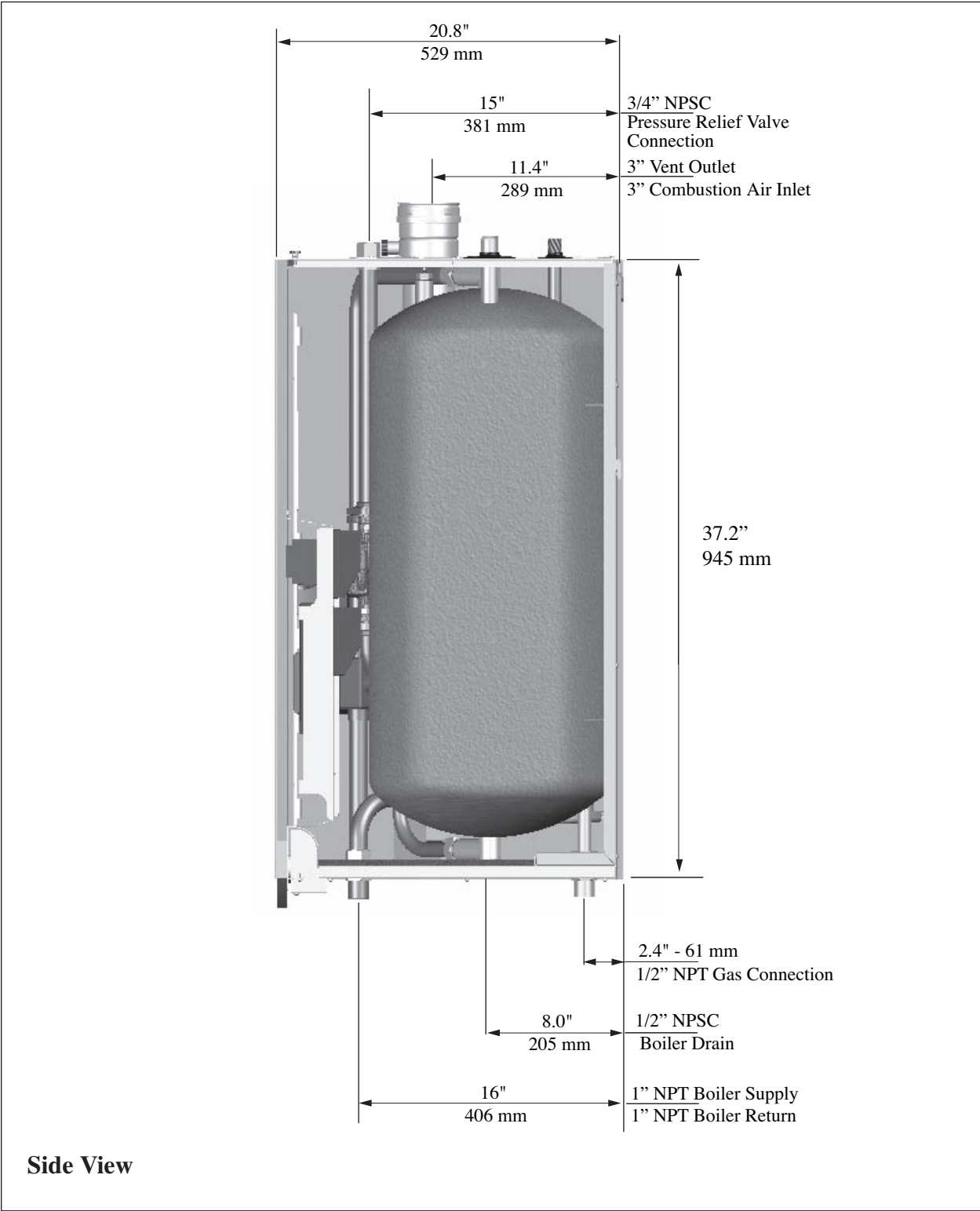

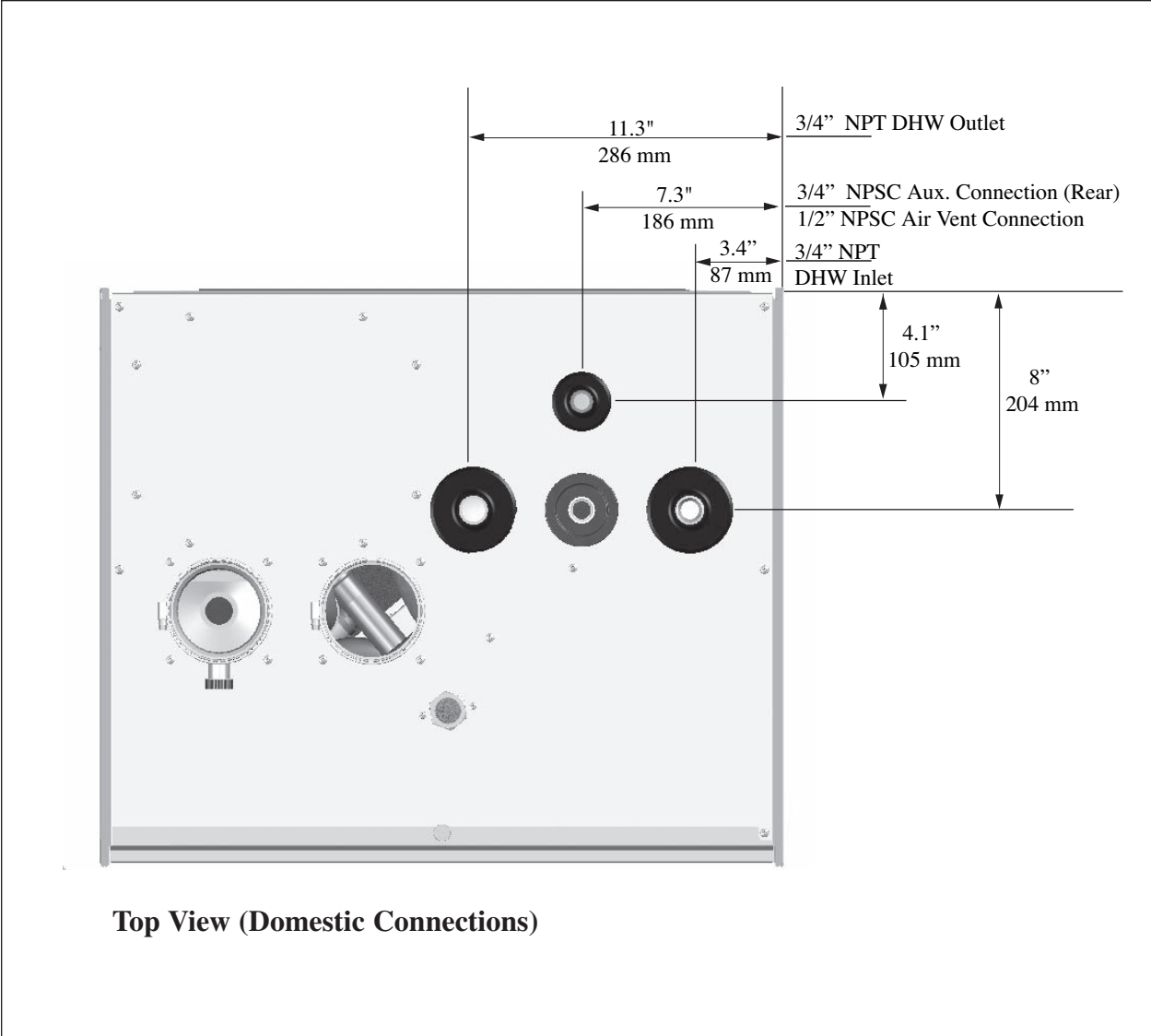

Product Specifications



Boiler Model	Fuel	DOE Heating Capacity Note 1 & 4	Input Note 4	Net IBR Rating Note 2	DOE Seasonal Efficiency AFUE Note 3	Shipping Weight Lbs / Kg
Excellence	Natural	99,000	110,000	86,000	95%	190 / 86
Excellence	Propane	87,000	97,000	76,000	95%	190 / 86

Note 1: The heating capacity of the PRESTIGE Excellence is based on the test requirements of the U.S. Department of Energy.

Note 2: The IBR rating is based on a piping and pick up allowance of 1.15. This allowance should be sufficient for the standard radiation requirements for a building load.

Note 3: Based on the given AFUE the PRESTIGE Excellence meets the energy efficiency guidelines established by Energy Star.

Note 4: Input and output ratings are shown for sea level applications. The PRESTIGE Excellence automatically derates the input at approximately 2% for every 1,000 Ft. of altitude. No alterations to the boiler or burner system is required.



Graph 2: Pressure Drop Comparison Excellence 110 vs Grundfos UPS 15-58F-FC

Delta T	GPM	Available System Head in Feet		
		Spd 1	Spd 2	Spd 3
20	8.7	---	---	4.5
30	5.8	1.7	7.7	11.2
40	4.3	4.7	10.9	14.2

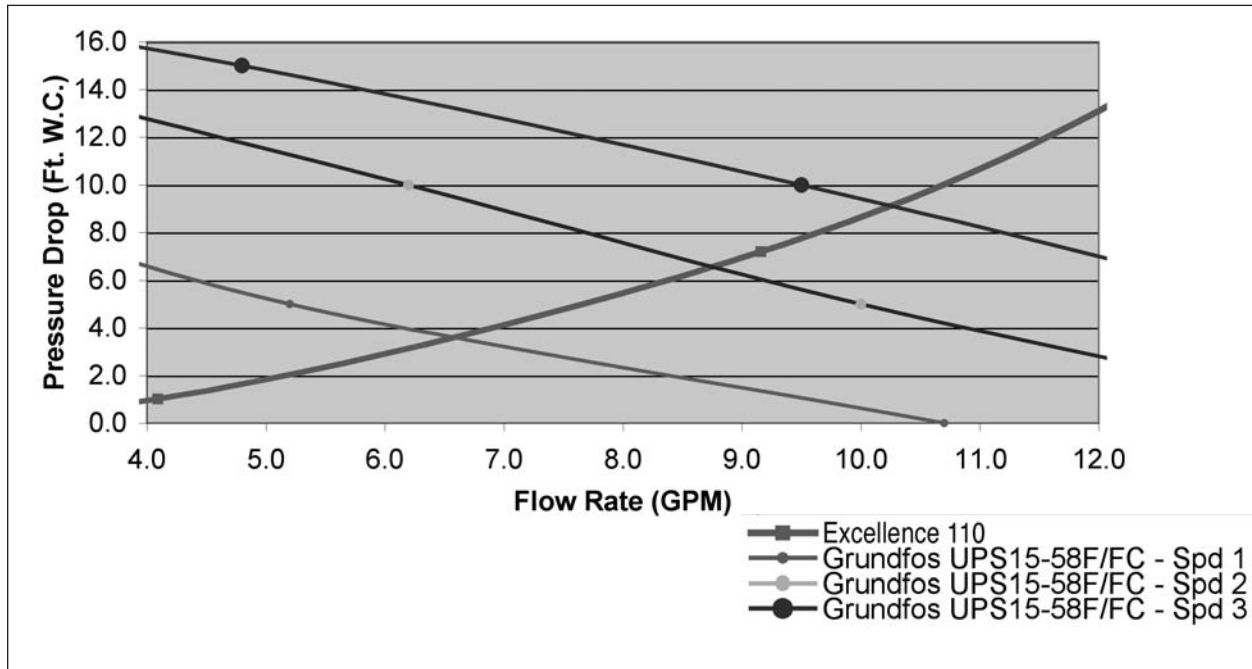

Note: Minimum allowable flow rate at full input: 5.0 gpm

Additional Quality Water Heating Equipment Available from Triangle Tube

Maxi-Flo and Spa Heat Exchangers



- Construction of high quality corrosion resistant stainless steel (AISI 316) or titanium
- Specially designed built-in flow restrictor to assure maximum heat exchange
- Compact and light weight
- Available in 5 sizes that can accommodate any size pool or spa

Smart Indirect Fired Water Heaters



- Exclusive Tank-in-Tank design
- Stainless steel construction
- Available in 8 sizes and 2 models
- Limited LIFETIME residential warranty
- 15 year limited commercial warranty
- Self cleaning/self descaling design

TTP Brazed Plate Heat Exchangers

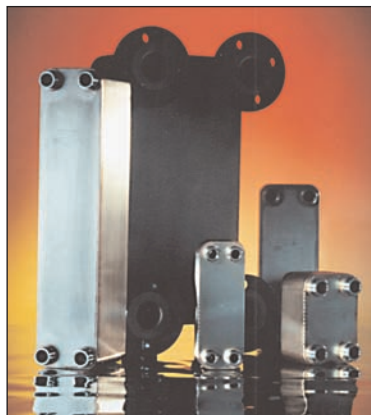

- For domestic water, snow melting, radiant floor, refrigeration
- Plates made of stainless steel, with a 99.9 % copper and brazed, ensuring a high resistance to corrosion
- Self cleaning and self descaling
- Computerized sizing available from Triangle Tube/Phase III
- Available in capacities from 25,000 BTU/hr to 5,000,000 BTU/hr



Freeway Center - 1 Triangle Lane - Blackwood, NJ 08012
Tel: (856) 228 8881 - Fax: (856) 228 3584
<http://www.triangle tube.com>
E-mail: Info@triangle tube.com

Member of

