

DISPLAY THIS CARD ON PRINCIPAL FRONTAGE OF WORK

CITY OF PORTLAND

BUILDING DEPARTMENT

PERMIT

PERMIT ISSUED

Permit Number: 081075

AUG 28 2008

CITY OF PORTLAND

Please Read Application And Notes, If Any, Attached

This is to certify that LILLEY DANIEL G /CRM Construction Services, Inc.

has permission to Pile repair on road side supporting 12 b... using ... and split fastening to existing ...

AT 39 PORTLAND PIER 030 H008001

provided that the person or persons, firm or corporation accepting this permit shall comply with all of the provisions of the Statutes of Maine and of the Ordinances of the City of Portland regulating the construction, maintenance and use of buildings and structures, and of the application on file in this department.

Apply to Public Works for street line and grade if nature of work requires such information.

Notification of inspection must be given and written permission procured before this building or part thereof is altered or closed-in. HEAVY NOTICE IS REQUIRED.

A certificate of occupancy must be procured by owner before this building or part thereof is occupied.

OTHER REQUIRED APPROVALS

Fire Dept. \_\_\_\_\_

Health Dept. \_\_\_\_\_

Appeal Board \_\_\_\_\_

Other \_\_\_\_\_

Department Name

Signature: Jeanne Bouke 8/28/08
Director - Building & Inspection Services

PENALTY FOR REMOVING THIS CARD



**City of Portland, Maine - Building or Use Permit Application**

389 Congress Street, 04101 Tel: (207) 874-8703, Fax: (207) 874-8716

|                       |                           |                     |
|-----------------------|---------------------------|---------------------|
| Permit No:<br>08-1075 | Issue Date:<br>08/28/2008 | CBL:<br>030 H008001 |
|-----------------------|---------------------------|---------------------|

|   |  |  |                      |
|---|--|--|----------------------|
| Location of Construction:<br>39 PORTLAND PIER | Owner Name:<br>LILLEY DANIEL G                       | Owner Address:<br>39 PORTLAND PIER                 | Phone:               |
| Business Name:                                | Contractor Name:<br>CRM Construction, Services, Inc. | Contractor Address:<br>94 Washington Street Auburn | Phone:<br>2076507860 |
| Lessee/Buyer's Name                           | Phone:   | Permit Type:<br>Alterations - Commercial           | Zone:<br>WCZ         |

|  |   |  |   |                    |
|--|---|--|---|--------------------|
| Past Use:<br>Law Offices of Dan Lilley | Proposed Use:<br>Law Offices/pile repair on road side supporting 12 bents using pin and splice fastening to existing underground piling | Permit Fee:  | Cost of Work:<br>\$0.00   | CEO District:<br>1 |
|  |   | FIRE DEPT:<br><input type="checkbox"/> Approved<br><input type="checkbox"/> Denied | INSPECTION:<br>Use Group: pier Type:<br>Piling Repair<br>Signature: JMB 8/28/08 |                    |

**Proposed Project Description:**  
Pile repair on road side supporting 12 bents using pin and splice fastening to existing underground piling

Signature: \_\_\_\_\_  
**PEDESTRIAN ACTIVITIES DISTRICT (P.A.D.)**  
 Action:  Approved  Approved w/Conditions  Denied  
 Signature: \_\_\_\_\_ Date: \_\_\_\_\_

Permit Taken By: jmb  
 Date Applied For: 08/27/2008

**Zoning Approval**

- This permit application does not preclude the Applicant(s) from meeting applicable State and Federal Rules.
- Building permits do not include plumbing, septic or electrical work.
- Building permits are void if work is not started within six (6) months of the date of issuance. False information may invalidate a building permit and stop all work..

**Special Zone or Reviews**

Shoreland  
 Wetland  
 Flood Zone  
 Subdivision  
 Site Plan *Existing Footprint*  
 Maj  Minor  MM   
 Date: JMB 8/28/08

**Zoning Appeal**

Variance  
 Miscellaneous  
 Conditional Use  
 Interpretation  
 Approved  
 Denied  
 Date: \_\_\_\_\_

**Historic Preservation**

Not in District or Landmark  
 Does Not Require Review  
 Requires Review  
 Approved  
 Approved w/Conditions  
 Denied  
 Date: \_\_\_\_\_

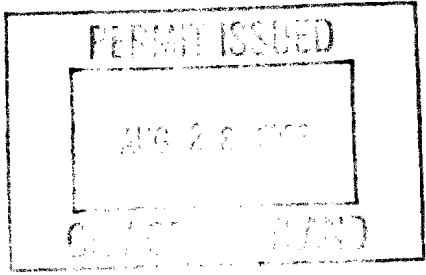

**CERTIFICATION**

I hereby certify that I am the owner of record of the named property, or that the proposed work is authorized by the owner of record and that I have been authorized by the owner to make this application as his authorized agent and I agree to conform to all applicable laws of this jurisdiction. In addition, if a permit for work described in the application is issued, I certify that the code official's authorized representative shall have the authority to enter all areas covered by such permit at any reasonable hour to enforce the provision of the code(s) applicable to such permit.

|   |         |      |       |
|---|---------|------|-------|
| SIGNATURE OF APPLICANT                      | ADDRESS | DATE | PHONE |
| RESPONSIBLE PERSON IN CHARGE OF WORK, TITLE |         | DATE | PHONE |

8/29/08 Inspected pile repair - Pinning of  
New 8x8 to existing driven pile.  
OK to proceed JMB

**City of Portland  
Inspection Services  
RETURN OF SERVICE**

On the 4<sup>th</sup> day of September, 2008, I made service of the  
Letter of notification upon Dan Lilley  
at 39 Portland Pier 30-H-8 structural repairs

By delivering a copy in hand.

By leaving copies at the individual's dwelling house or usual place of abode with a person of suitable age or discretion who resides therein and whose name is

By delivering a copy to an agent authorized to receive service of process, and whose name is Bob Morin

By (describe other manner of service) \_\_\_\_\_

DATED: 9/4/08

Louis Bonke  
Signature of Person Making Service

Inspections Division Director  
Title

I have received the above-referenced documents

[Signature]  
Signature of Person Receiving Service

Refused to Sign

Unable to Sign





# PORTLAND MAINE

*Strengthening a Remarkable City, Building a Community for Life* • [www.portlandmaine.gov](http://www.portlandmaine.gov)

Director of Planning and Urban Development  
Penny St. Louis Littell

Inspection Services, Director  
Jeanie Bourke

Daniel G. Lilley, Esq  
39 Portland Pier  
Portland, Maine 04101

RE: 39 Portland Pier, CBL: 030 H008001, Permit #08-1075

Dear Sir,

As a result of the City's recent sidewalk repairs adjacent to your building at 39 Portland Pier, it has become apparent to the City of Portland Inspections Division that the structural integrity of this building is in question. Several of the pilings and carrying timbers supporting the building are rotted, have not been properly maintained, or were improperly replaced.

On August 27, 2008 Bob Morin applied for a permit in this office to repair 12 pilings on the east side (adjacent to the city ROW) of the building. Approvals were granted on August 28, 2008 to begin repairs. Mr. Morin confirmed, at that time, that he was not aware of any recent structural analysis of the support systems under the building. He offered to contact Wayne Duffet of TEC Associates in order to begin this process.

This letter formalizes the condition of approval noted on permit #08-1075, namely, that a full structural analysis of the existing piles and bents be submitted to this office within 30-45 days of the issuance of the building permit (August 28, 2008). Please note that any structural work requires a permit per Code Sec. 105 of the International Building Code 2003.

I am happy to answer any questions about this matter.

I can be reached at 207-874-8715.

Sincerely,

A handwritten signature in black ink that reads "Jeanie Bourke". The signature is written in a cursive style with a large, looped initial "J".

Jeanie Bourke  
Inspections Division Director  
City of Portland

Cc: Penny Littell, Director of Planning and Urban Development

Attachment: Building Permit Condition of Approval Doc



**City of Portland, Maine - Building or Use Permit**

389 Congress Street, 04101 Tel: (207) 874-8703, Fax: (207) 874-8716

|                              |  |                            |
|------------------------------|--|----------------------------|
| <b>Permit No:</b><br>08-1075 | <b>Date Applied For:</b><br>08/27/2008 | <b>CBL:</b><br>030 H008001 |
|------------------------------|--|----------------------------|

|  |   |   |                                |
|--|---|---|--------------------------------|
| <b>Location of Construction:</b><br>39 PORTLAND PIER | <b>Owner Name:</b><br>LILLEY DANIEL G                       | <b>Owner Address:</b><br>39 PORTLAND PIER                 | <b>Phone:</b>                  |
| <b>Business Name:</b>                                | <b>Contractor Name:</b><br>CRM Construction, Services, Inc. | <b>Contractor Address:</b><br>94 Washington Street Auburn | <b>Phone</b><br>(207) 650-7860 |
| <b>Lessee/Buyer's Name</b>                           | <b>Phone:</b>   | <b>Permit Type:</b><br>Alterations - Commercial           |                                |

|  |  |
|--|--|
| <b>Proposed Use:</b><br>Law Offices/pile repair on road side supporting 12 bents using pin and splice fastening to existing underground piling | <b>Proposed Project Description:</b><br>Pile repair on road side supporting 12 bents using pin and splice fastening to existing underground piling |
|--|--|

|   |   |                                 |   |
|---|---|---------------------------------|---|
| <b>Dept:</b> Zoning   | <b>Status:</b> Approved with Conditions | <b>Reviewer:</b> Jeanine Bourke | <b>Approval Date:</b> 08/28/2008                        |
| <b>Note:</b>  |   |                                 | <b>Ok to Issue:</b> <input checked="" type="checkbox"/> |
| 1) All work being performed shall be in the existing footprint  |   |                                 |   |
| 2) This permit is being approved on the basis of plans submitted. Any deviations shall require a separate approval before starting that work. |   |                                 |   |

|   |   |                                 |   |
|---|---|---------------------------------|---|
| <b>Dept:</b> Building   | <b>Status:</b> Approved with Conditions | <b>Reviewer:</b> Jeanine Bourke | <b>Approval Date:</b> 08/27/2008                        |
| <b>Note:</b>  |   |                                 | <b>Ok to Issue:</b> <input checked="" type="checkbox"/> |
| 1) This permit is approved with the agreement that a full structural analysis of the existing piles and bents is submitted within 30-45 days and a separate application for permit is required for the associated work. |   |                                 |   |
| 2) Permit approved based on the plans submitted and reviewed w/owner/contractor, with additional information as agreed on and as noted on plans.  |   |                                 |   |

|  |
|--|
| <b>Comments:</b>   |
| 8/27/2008-jmb: Bob Leeman came in with contractor Bob Morin to expedite the work to repair the piles while the road work the city is doing has allowed greater access to the effected area. Bob M. Verified that he is not aware of an engineers assessment of the pilings at the middle beam and water side |



**BUILDING PERMIT INSPECTION PROCEDURES**

Please call 874-8703 or 874-8693 (ONLY)

to schedule your inspections as agreed upon

Permits expire in 6 months, if the project is not started or ceases for 6 months.

The Owner or their designee is required to notify the inspections office for the following inspections and provide adequate notice. Notice must be called in 48-72 hours in advance in order to schedule an inspection:

By initializing at each inspection time, you are agreeing that you understand the inspection procedure and additional fees from a "Stop Work Order" and "Stop Work Order Release" will be incurred if the procedure is not followed as stated below.

A Pre-construction Meeting will take place upon receipt of your building permit.

X Rough Framing of the pile repair  
X Final at completion

Certificate of Occupancy is not required for certain projects. Your inspector can advise you if your project requires a Certificate of Occupancy. All projects DO require a final inspection.

If any of the inspections do not occur, the project cannot go on to the next phase, REGARDLESS OF THE NOTICE OR CIRCUMSTANCES.

CERIFICATE OF OCCUPANICES MUST BE ISSUED AND PAID FOR, BEFORE THE SPACE MAY BE OCCUPIED.

[Signature]  
Signature of Applicant/Designee

8/28/08  
Date

[Signature]  
Signature of Inspections Official

8/28/08  
Date





# General Building Permit Application

If you or the property owner owes real estate or personal property taxes or user charges on any property within the City, payment arrangements must be made before permits of any kind are accepted.

|   |   |  |
|---|---|--|
| Location/Address of Construction: <u>39 Portland Pier</u>   |   |  |
| Total Square Footage of Proposed Structure/Area   |   | Square Footage of Lot  |
| Tax Assessor's Chart, Block & Lot<br>Chart#      Block#      Lot#<br><u>30      H      008</u>  | Applicant * <b>must</b> be owner, Lessee or Buyer*<br>Name <u>Dan Lilley</u><br>Address <u>35 Portland Pier</u><br>City, State & Zip <u>Portland Me</u> | Telephone:   |
| Lessee/DBA (If Applicable)  | Owner (if different from Applicant)<br>Name<br>Address<br>City, State & Zip   | Cost Of Work: \$ <u>10,520.</u><br>C of O Fee: \$ _____<br>Total Fee: \$ <u>130.00</u> |
| Current legal use (i.e. single family) <u>Law OFFICES - Dan Lilley</u><br>If vacant, what was the previous use? _____<br>Proposed Specific use: <u>same</u><br>Is property part of a subdivision? _____ If yes, please name _____<br>Project description: <u>Replace deteriorated pile with new - PT piles<br/>12 support piles under beams</u> |   |  |
| Contractor's name: <u>C.R.M. Construction</u><br>Address: <u>94 Washington Street North</u><br>City, State & Zip <u>Ansbum Maine 04210</u> Telephone: <u>650-7860</u><br>Who should we contact when the permit is ready: <u>Bob Moin</u> Telephone: <u>650-7860</u><br>Mailing address: <u>same</u>   |   |  |

**Please submit all of the information outlined on the applicable Checklist. Failure to do so will result in the automatic denial of your permit.**

In order to be sure the City fully understands the full scope of the project, the Planning and Development Department may request additional information prior to the issuance of a permit. For further information or to download copies of this form and other applications visit the Inspections Division on-line at [www.portlandmaine.gov](http://www.portlandmaine.gov), or stop by the Inspections Division office, room 315 City Hall or call 874-8703.

I hereby certify that I am the Owner of record of the named property, or that the owner of record authorizes the proposed work and that I have been authorized by the owner to make this application as his/her authorized agent. I agree to conform to all applicable laws of this jurisdiction. In addition, if a permit for work described in this application is issued, I certify that the Code Official's authorized representative shall have the authority to enter all areas covered by this permit at any reasonable hour to enforce the provisions of the codes applicable to this permit.

Signature: Robert Moin Date: 8-27-08

**This is not a permit; you may not commence ANY work until the permit is issue**



12 Piling posts replaced  
on Portland Pier Road side only  
8' O.C.

Descriptor/Area

- A: 2SFR  
1080 sqft
- B: WD  
64 sqft
- C: 1SFR  
450 sqft

Commercial

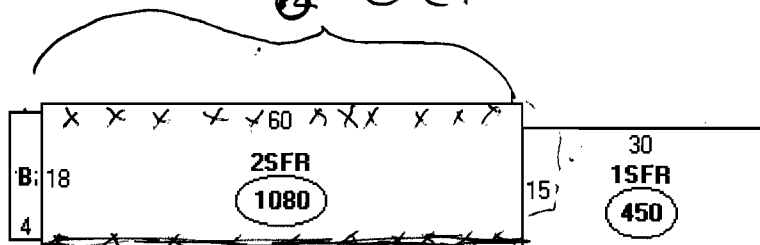

Water side





39 Portland Pier  
Dam Ledge Pile Repairs

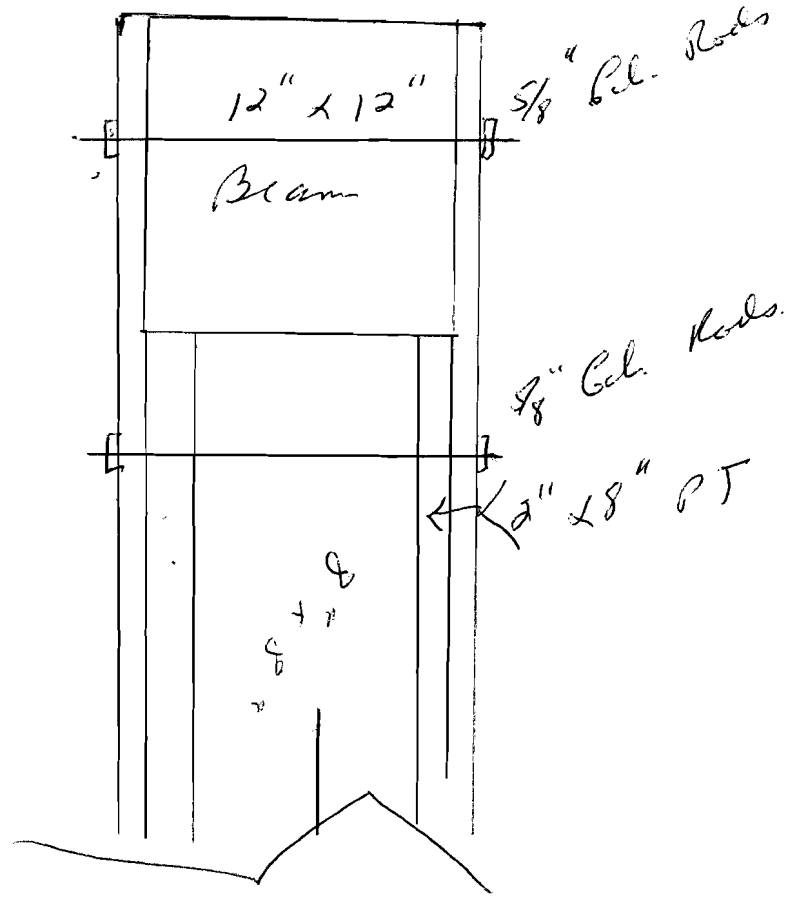



39 Portland Pier

Dan Lilley

Pile Repairs

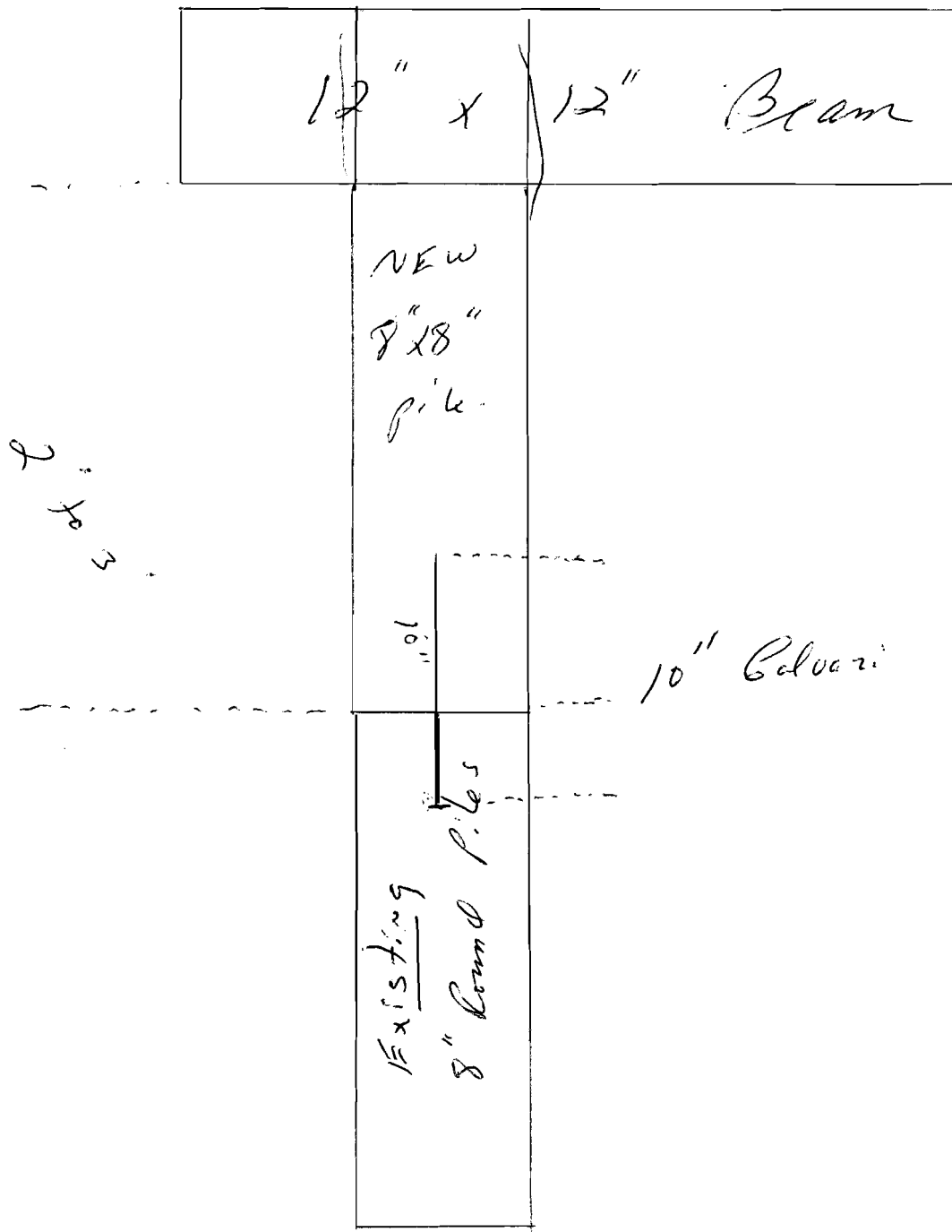



**Deanna Flanagan**

---

**From:** Daniel Lilley  
**Sent:** Thursday, August 21, 2008 9:17 AM  
**To:** Deanna Flanagan  
**Subject:** RE:

Deanna. I was not apprised by the city that their work would impinge on my property or could cause damage to my property or create a danger and certainly not cost me money for their construction. All decisions on those issues will be made with consultation with Bob Morin first. He is my agent in this matter.

Print and show this e-mail to Shaw Brothers, the city or anyone else who needs to know.

Anything that any of them do that causes damage to my property or personal injury is at their risk and they will be fully liable.

s/ Dan Lilley

-----Original Message-----

**From:** Deanna Flanagan  
**Sent:** Thursday, August 21, 2008 8:45 AM  
**To:** Daniel Lilley  
**Subject:** RE:

Bob Morin - 650-7860

DEANNA FLANAGAN



COMMERCIAL

PEARL

030  
H-008

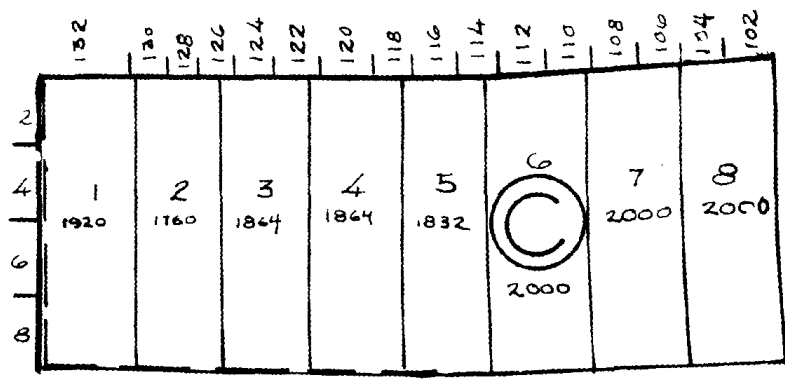
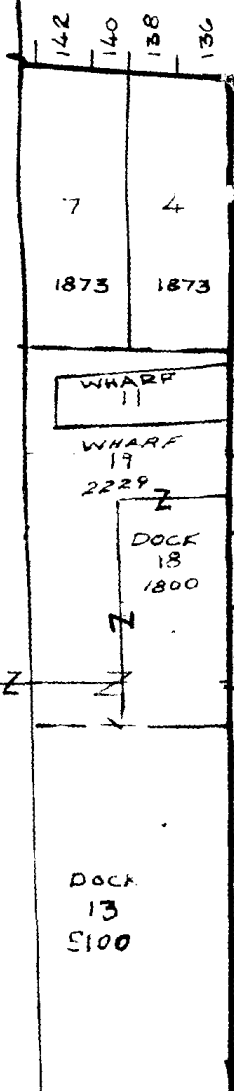

20' PASSAGE

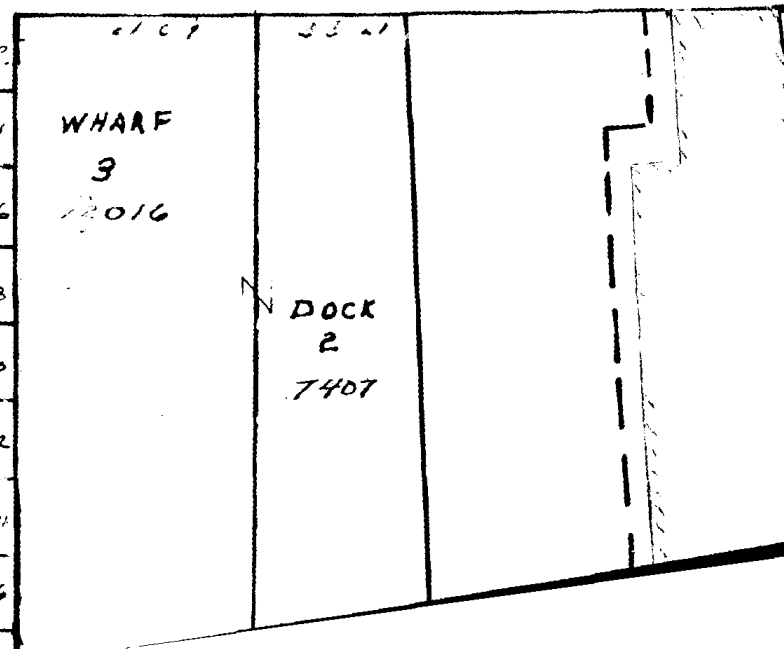

PASSAGE

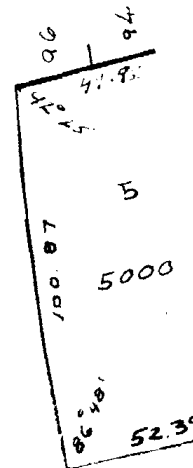

SHEET 31-A

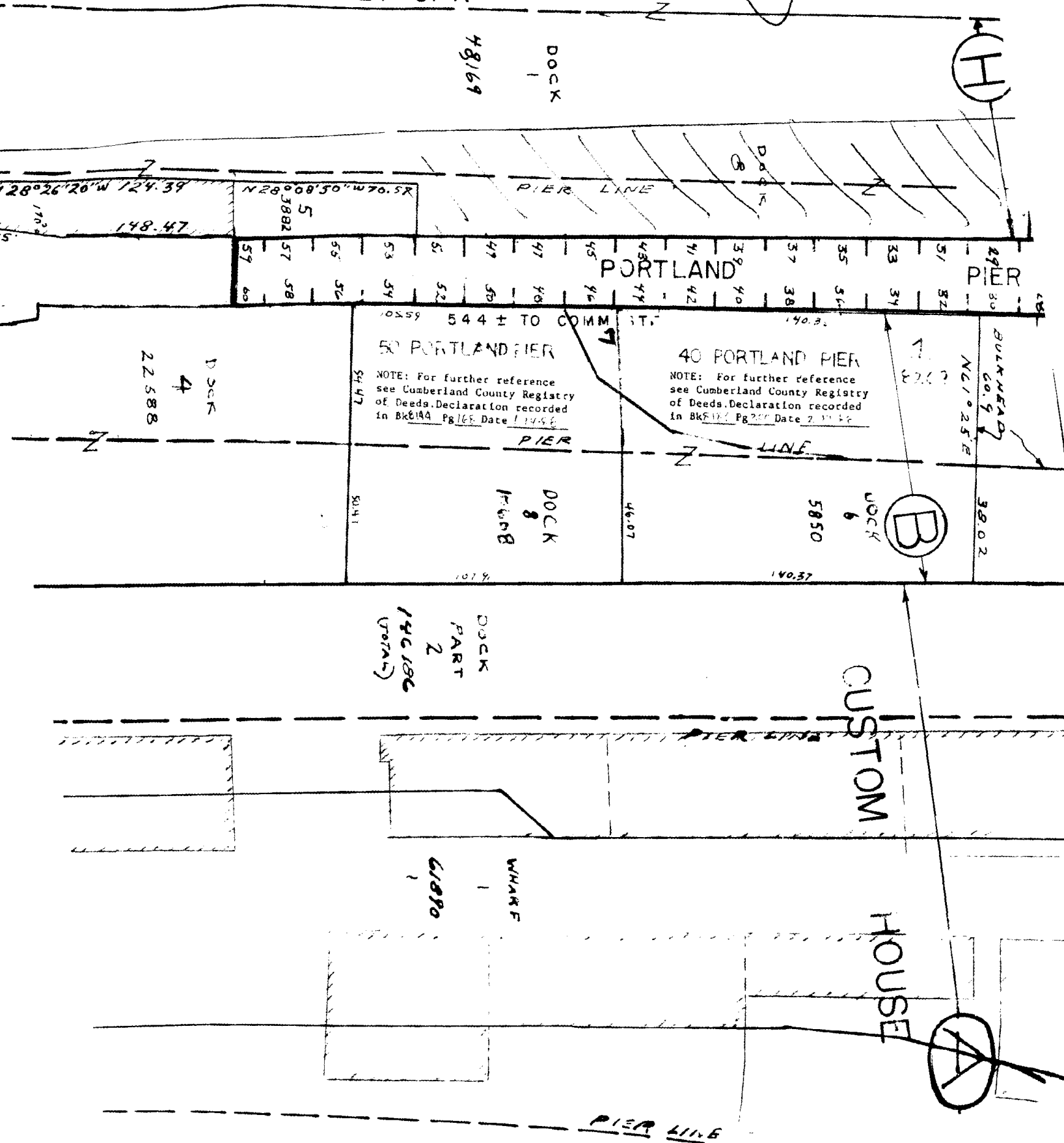

48,169

DOCK 1

(H)

N 28° 26' 26" W 124.39  
176.3  
148.47

N 28° 08' 50" W 70.57  
5  
3882 57 58  
57 60

PIER LINE

DOCK 8

PORTLAND

PIER 30

DOCK 4  
22,588

50 PORTLAND PIER  
NOTE: For further reference see Cumberland County Registry of Deeds. Declaration recorded in Bk 114A Pg 165 Date 1/14/42

40 PORTLAND PIER  
NOTE: For further reference see Cumberland County Registry of Deeds. Declaration recorded in Bk 114A Pg 207 Date 2/11/42

PIER LINE

DOCK 8  
14,008

(B)

DOCK 6  
5850

BULKHEAD  
60.9  
N 1° 25' E

38.02

DOCK PART 2  
14,186  
(VOTAN)

CUSTOM HOUSE

WHARF 1  
6,090

HOUSE

(A)

PIER LINE