

DESIGNED BY: Larry Wichroski, P.E.
 DRAWN BY: LAW
 JOB NO.: 00416
 DATE: 03-15-2016

| | |
|------------|----|
| REVISIONS: | |
| | |
| | |
| | |
| | |
| SHEET: | S1 |

STRUCTURAL NOTES:

- CODE: Comply with the 2009 International Building Code (IBC).
- DESIGN LOADS:**
 Roof = 20.0 psf, Floors = 16.0 psf.
 Live Loads: Roof = 45.0 psf (Plus Drift), Office Space = 50.0 psf, Common Areas = 100.0 psf.
- Wind:
 Wind Speed = 100 mph, Exposure "C", $k_w = 1.0$
 Uplift Loads: Roof framing is subject to an uplift load.
 Overall Roof = 18 PSF
 12 Strip Around Perimeter = 22 PSF
 12 Spaces At Blending Corners = 24 PSF
- STEEL:**
 1. Rolled sections and plates: ASTM A-36, $F_y = 36$ ksi.
 2. Wide Flange Shapes - ASTM A572, $F_y = 50$ ksi.
 3. Steel Lally Columns - ASTM A513, $F_y = 23$ ksi, 16 gage steel filled w/ 3,000 psi concrete.
 4. Bolts and plate anchors: ASTM A-307, $F_u = 58$ ksi.
 5. Submit shop drawings. Fabricate after Engineers review.
- WOOD:**
 1. General:
 a. Each piece of lumber shall be "S-DRY" and bear the grade stamp of a grading rules agency and be approved by the American Lumber Standards Committee.
 b. Double up studs at joints and under beams.
 c. Do not notch or drill joists, beams or load bearing studs without approval.
 2. Connections:
 a. Nail roof plywood with 8d common at 6" o.c. at all edges and boundary members and 10" o.c. at intermediate supports.
 b. Nail wall plywood with 10d common nails at 6" o.c. at all edges and boundary members and 12" o.c. at intermediate supports.
 3. Structural Saw Lumber:
 a. 2 x 6 firm 2 x 14 joists: Spruce Pine Fir No. 2 with F_b (repetitive) = 1200 p.s.i.
 b. Joists: Spruce Pine Fir No. 2 with F_b (repetitive) = 1200 p.s.i.
 c. Micro-L Beams (LVL): $F_b = 3000$ psi, $F_v = 205$ psi, $E = 2,000$ ksi
 4. Plywood:
 a. Roof Sheathing: C-D INT-APA (PSI-94) with exterior glue; 5/8" with Identification Index 48/24. Lay up with face grain perpendicular to supports. Stagger joints. Each plywood piece to be continuous over a minimum of two spans with a minimum width of 1'-0" unless blocking is provided at all joints.
 b. Lay up with face grain perpendicular to supports. Stagger joints. Each plywood piece to be continuous over a minimum of two spans with a minimum width of 1'-0" unless blocking is provided at all joints.
 c. Wall Sheathing: C-D INT-APA (PSI-74) with exterior glue, 1/2" with Identification Index 24/0. All panel edges backed with 2" nominal or wider framing.
- SUPPLEMENTARY NOTES:**
 1. Verify all dimensions and conditions with architectural drawings prior to starting work. Notify the Engineer of any discrepancies or inconsistencies.
 2. Provide all necessary temporary bracing, shoring, guying or other means to avoid excessive stresses and to hold structural elements in place during construction.

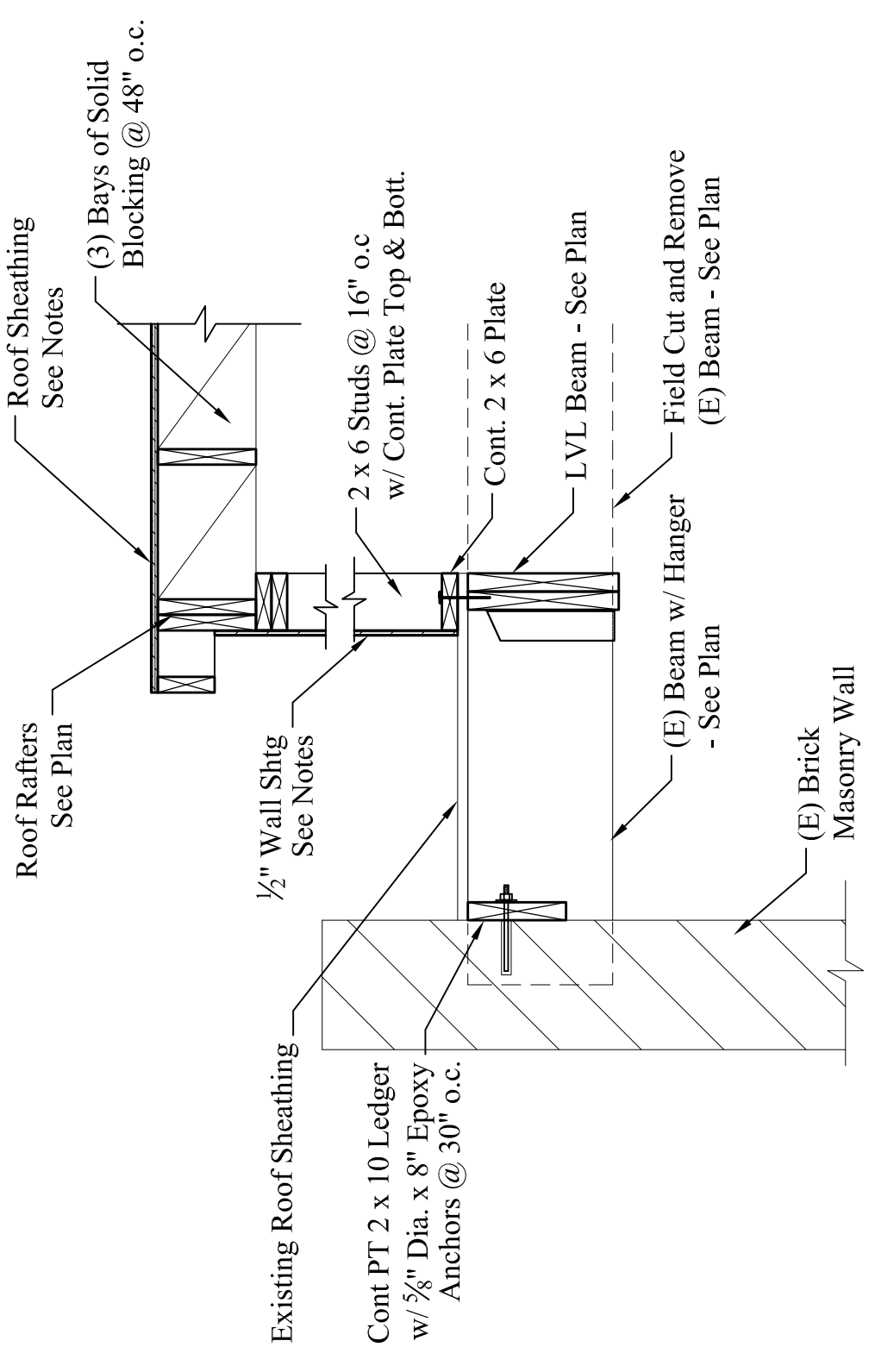

1 WINDOW HDR @ EXTERIOR WALL
 Scale: 3/4" = 1'-0"

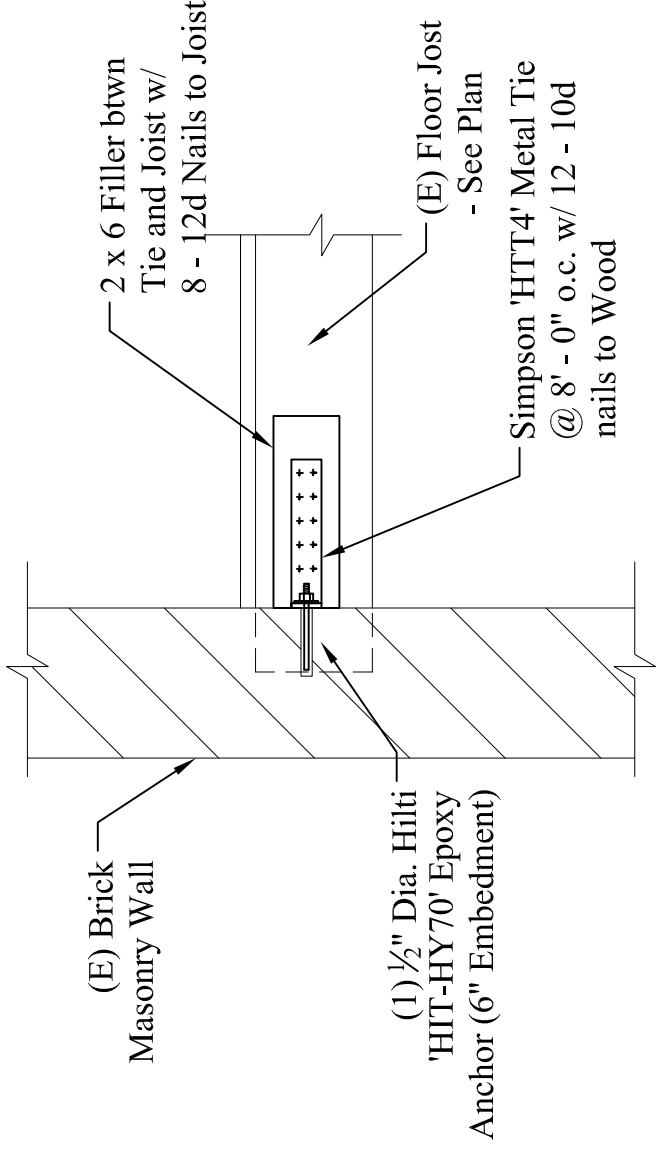

2 DORMER SIDE WALL DETAIL
 Scale: 3/4" = 1'-0"

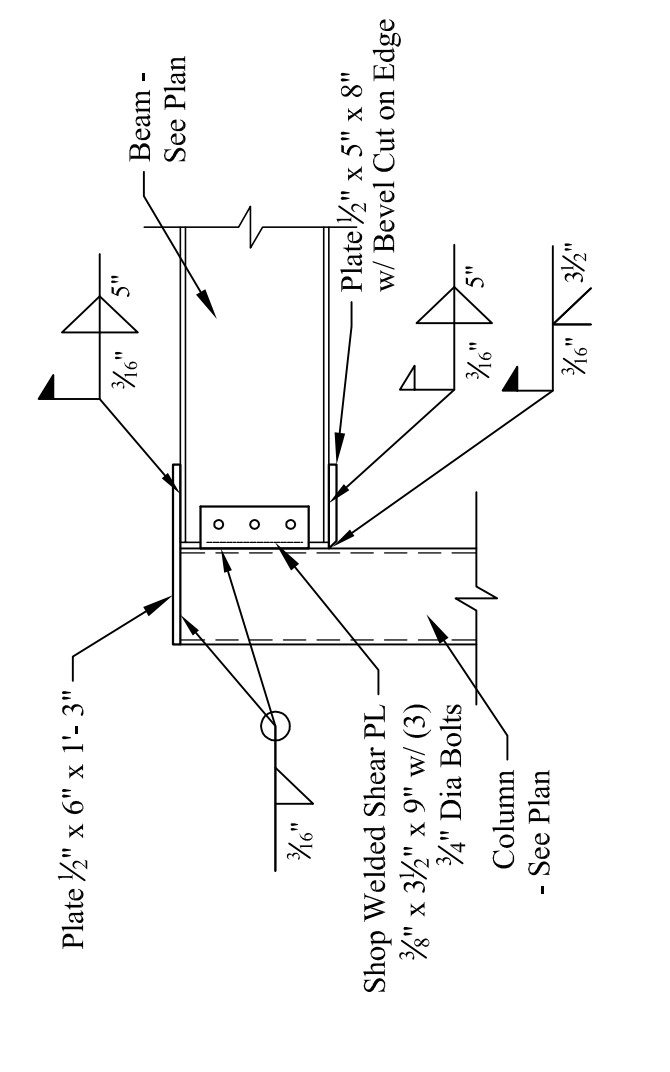

3 SISTERS BEAM SUPPORT @ (E) MAS. WALL
 Scale: 3/4" = 1'-0"

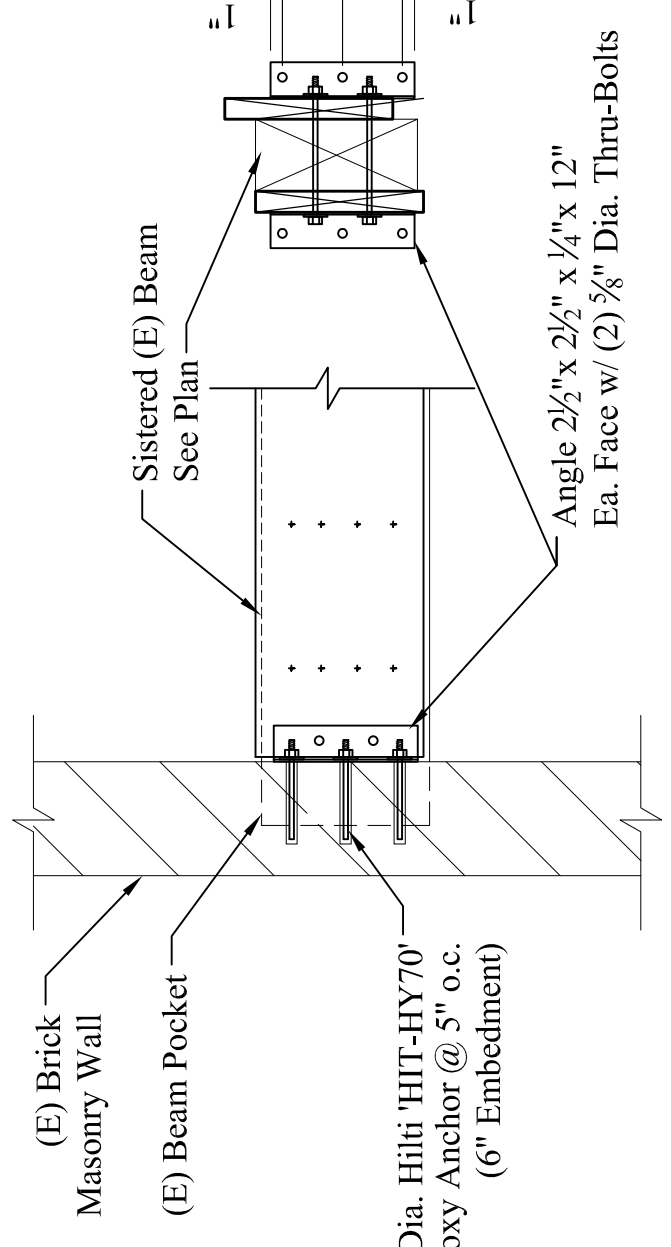

4 BEAM TIES @ EXIST. BRICK WALL
 Scale: 3/4" = 1'-0"

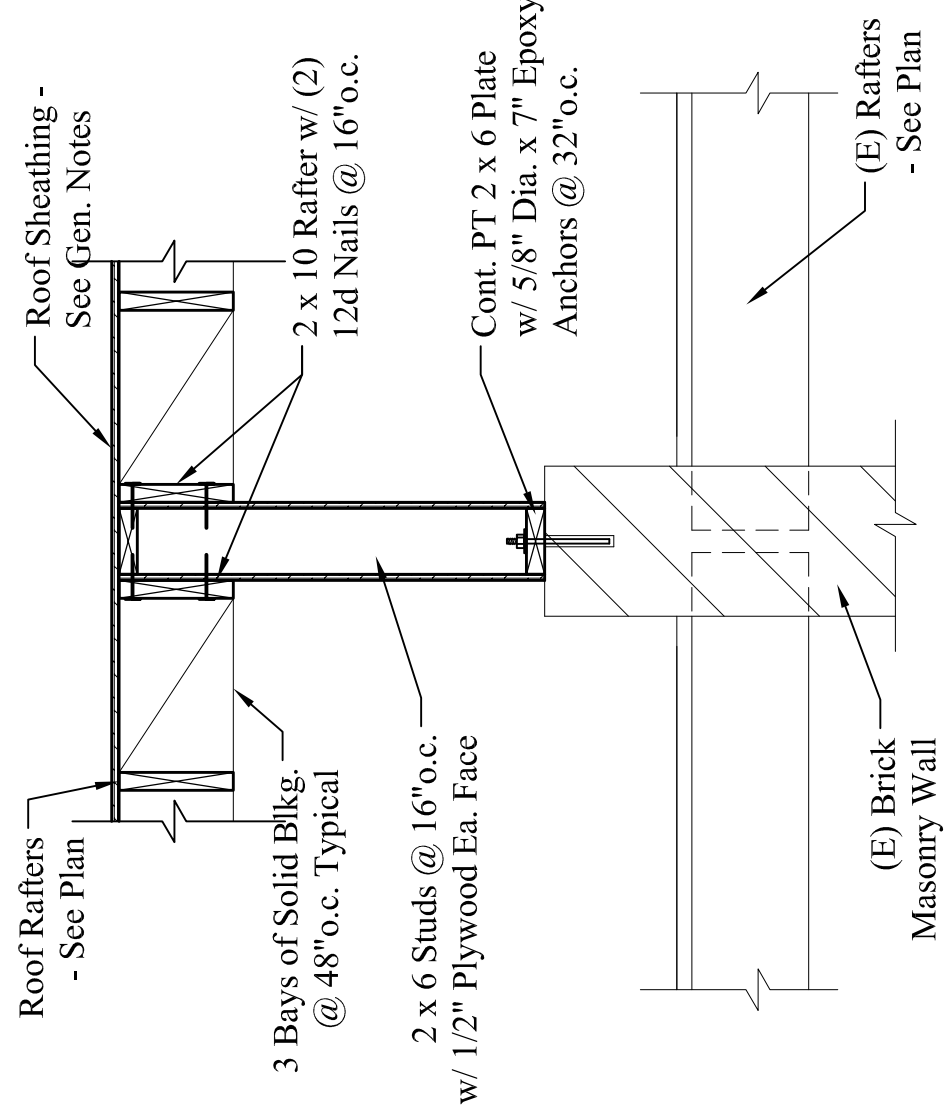

5 STL BEAM TO STL. POST CONN.
 Scale: 3/4" = 1'-0"

6 STL BEAM TO STL. POST CONN.
 Scale: 3/4" = 1'-0"

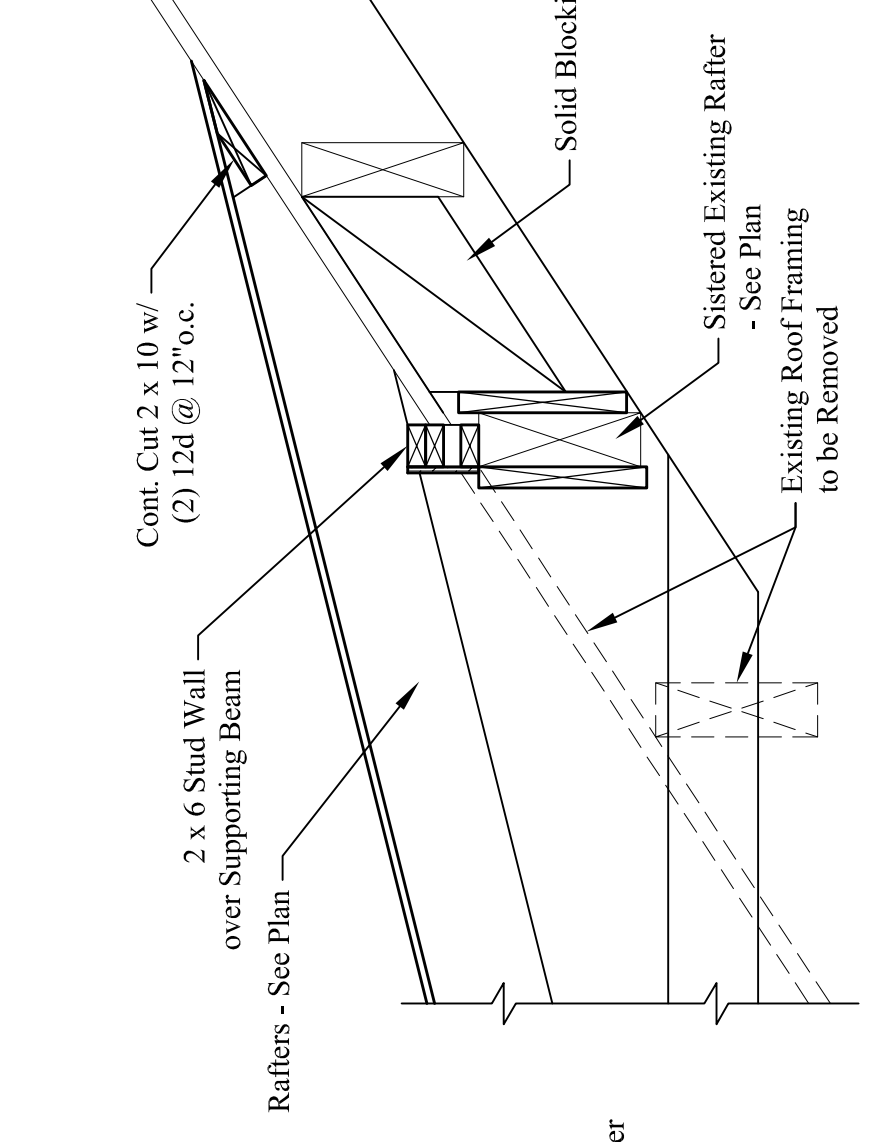

7 STL COL. @ (E) MAS. WALL
 Scale: 3/4" = 1'-0"

9 ROOF @ EXIST. ROOF FRAMING
 Scale: 3/4" = 1'-0"

10 ROOF @ EXIST. ROOF FRAMING
 Scale: 3/4" = 1'-0"