

Twin Pipe PVC /
CPVC Venting
options for Rinnai
Ultra Series
Condensing Tankless
Water Heaters.

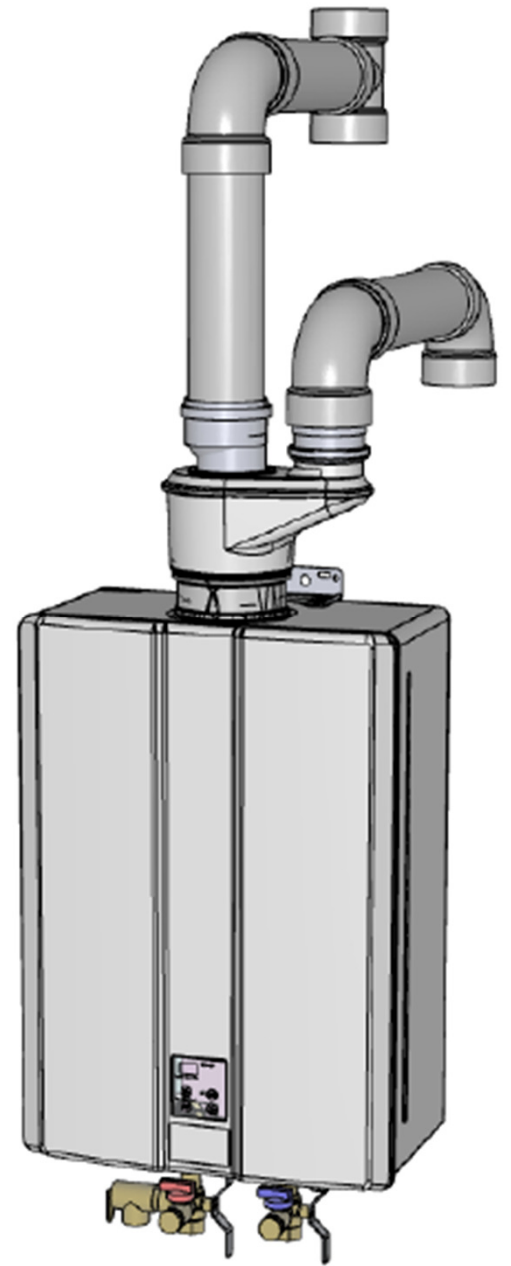

Rinnai[®]

Purpose:

The purpose of this presentation is to provide information concerning new venting options available for the following Rinnai Ultra Series Tankless Water Heater models.

- RU98i (REU-KB3237FFUD-US)
- RU80i (REU-KB2530FFUD-US)

NOTE: The information contained in this presentation is an overview and applies only to the Rinnai Ultra Series water heater models listed above. For more complete information including warnings and notices, refer to the Twin Pipe Venting Guide and the water heater's installation manual.



Rinnai®

Changes:

The changes consist of:

- Certification of PVC and CPVC as optional venting materials for the Rinnai Ultra Series water heaters (RU models).
- Extension of maximum equivalent vent lengths (gas type and vent diameter dependent).
 - These changes are immediate and can be implemented on existing RU model water heaters already in distribution (**not applicable for RC models**).
 - This will allow our customers more flexibility when installing the product.

Rinnai has certified a Ubbink® 3”/5” to 3”/3” Concentric-to-Twin Pipe Adaptor, and other venting equipment, to be used with an optional PVC / CPVC twin pipe venting system for both Natural Gas and Propane models.

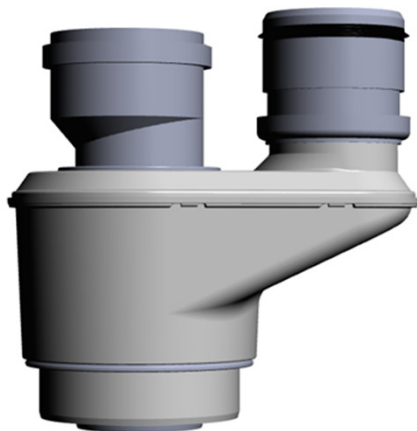

Rinnai®

Changes (cont.):

The newly certified system is comprised of a (Ubbink) Concentric to Twin Pipe adaptor, PVC / CPVC pipes, fittings and either the IPEX Concentric Vent Kit Assembly (CVK), Snorkel termination, Tee termination or IPEX Low Profile termination kit (The Twin Pipe adapter is adaptable to 3 and 4 inch diameter vent pipes).

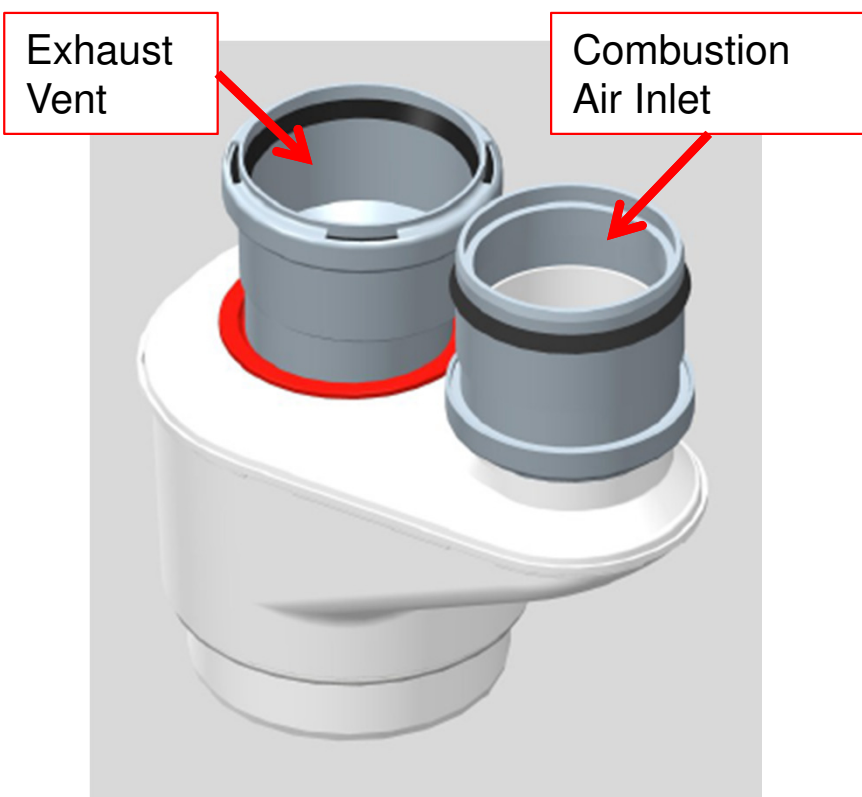

NOTE:

The Ubbink Concentric-to-Twin Pipe Adaptor is ULC S636 approved and is listed by the applicable agencies having jurisdiction and is certified for use throughout the U.S. and Canada. The Concentric-to-Twin Pipe Adaptor is supplied exclusively through Rinnai and/or its distributors.

The Twin-Pipe adaptor is the only component available from Rinnai. All other approved PVC/CPVC venting materials and terminations are to be field supplied through local distributors.

Ubbink Concentric-to-Twin Pipe Adaptor.

Rinnai[®]

Installation Requirements:

- If the installer chooses to utilize twin pipe PVC / CPVC venting, the Rinnai approved twin pipe adaptor **MUST** be used.
- Installation should be performed by a licensed professional.
- Use only the materials listed in the Water Heater Manual and the Twin Pipe venting guide for vent, air intake pipe and fittings. Failure to comply with this warning could result in personal injury, death or property damage.
- Installations must comply with the National Fuel gas code, ANSI Z223.1/NFPA 54 for U.S. installations or CSA B149.1 for Canadian installations.
- All PVC/CPVC IPEX Concentric Vent Kit assemblies are certified to ULC S636. Where ULC S636 compliance is required, use only System 636 pipe, fittings and cement at terminal connection.
- All PVC/CPVC exhaust vent material used in Canada must be S636 certified.
- The listed vent, vent fittings, terminations, cleaner and glue are all certified as part of the water heater vent system.

Installation Requirements (cont.):

- DO NOT mix pipe, fittings, cements or joining methods from different vent manufacturers. This can void the certification.
- DO NOT use cellular core PVC, CPVC nor Radel piping for the vent. Vents must be of solid core pipes only.
- DO NOT use PVC/CPVC venting on NON-Condensing units.
- DO NOT operate the unit until the venting is completely installed and all solvents and glues have cured.
- If used, a masonry chimney can ONLY be used as a pipe chase. NO OTHER appliance or fireplace can be connected to the chimney.



NOTICE:

PVC / CPVC venting **CANNOT** be used with the KB Condensing Water Heaters under the following conditions:

- The water heater is installed in a recirculation system and the thermostat setting is greater than 150°F (65.5C).
- The water heater is used in a combination domestic hot water and space heating application which requires a thermostat setting greater than 150°F (65.5C).

Rinnai®

Installation Requirements (materials):

Certified Vent and Air Piping Materials			
Item	Material	Standard for Installation in North America	
		United States	Canada
Thermoplastic Piping Materials			
Vent or combustion air intake pipe and fittings	PVC Schedule 40	ANSI/ASTM D1785	Thermoplastic vent pipe must be certified to ULC S636. Intake Pipe may be of any material listed (left).
	PVC-DWV	ANSI/ASTM D2665	
	CPVC schedule 40	ANSI/ASTM F441	
PVC pipe cement & primer	PVC	ANSI/ASTM D2564	
	CPVC	ANSI/ASTM F493	
IPEX bird screens (purchased separately)			
Termination vent screens	Polyethylene	3" Vent screen: IPEX part# 196051; 4" Vent screen: part# 196052 (screens are friction fit inside termination fitting bells).	

NOTE: The listed vent, vent fittings, termination, cleaner and glue are all certified as part of the water heater vent system.

Components of any certified system CANNOT be substituted with any other vent system(s) or unlisted pipes and/or fittings. All listed components, primers and glues are part of the certified vent system and therefore MUST be from a single manufacturer.



Installation Location:

- **Environment:**

- Air surrounding the water heater, venting and vent termination(s) is used for combustion and must be free of any compounds that can cause corrosion of internal components. These include corrosive compounds that are found in aerosol sprays, detergents, bleaches, cleaning solvents, oil based paints/varnishes, and refrigerants.
- The air in beauty shops, dry cleaning stores, photo processing labs and storage areas for pool supplies often contains these compounds. Therefore it is recommended that outdoor models be used for these locations where possible.
- The water heater, venting and vent termination(s) should not be installed in any areas where the air may contain these corrosive compounds. If it is necessary for a water heater to be located in areas which may contain corrosive compounds the instructions on the following page are highly recommended.

NOTE: Damage or repairs due to corrosive compounds in the air are not covered by warranty.

Installation Location (cont.):

- **Important considerations:**

- Before installation, consider where possible contaminated air has the ability to move within the building to the water heater location.
- Where possible, install the water heater in a sealed closet so that it is protected from the potential of contaminated indoor air.
- Locate the vent outlet where flue gases will not harm surrounding plants and / or equipment. All vent locations must adhere to the recommended vent/air terminal position as outlined in the PVC/CPVC venting guide.
- Avoid locations where prevailing winds could affect the performance of the water heater or cause recirculation of the exhaust flue gases.
- Water heater flue gases must be piped from the appliance to the outside. The installer **MUST** adhere to the instructions provided in the PVC/CPVC venting guide and the most recent water heater installation manual and all applicable codes.
- The vent pipe must terminate either through the sidewall or through the roof. The exhaust/vent termination and intake air openings shall adhere to clearances as set forth in the Direct Vent Termination Clearances diagram found in the owner's manual and/or twin pipe venting guide.

Installation Location (cont.):

- The exhaust and combustion air must terminate through the same sidewall or roof. The terminations must be in the same pressure zone and face in the same direction.
 - When using the Twin pipe PVC / CPVC adapter each condensing tankless water heater requires a separate vent system.
 - If common venting is required, refer to the Rinnai Common Vent Installation Manual for instructions on optional venting methods as well as to verify which tankless models may be common vented.
 - Use only 3" or 4" PVC/CPVC for venting.
- **Additional Clearance Requirements:**
 - Avoid termination locations near a dryer vent.
 - Avoid termination locations near commercial cooking exhaust.
 - Install termination at least 12" above grade or anticipated snow level.

Installation Location (cont.):

- **Vents shall not terminate:**
 - Over public walkways or near soffit vents or crawlspace vents or other areas where condensate or vapor could create a nuisance or hazard or cause property damage.
 - Where condensate or vapor could cause damage or could be detrimental to the operation of regulators, relief valves or other equipment.
- **Important considerations for locating vent terminations under a soffit (vented or unventilated) or eave vent or to a deck or porch:**
 - DO NOT install vent termination under a soffit vent such that exhaust can enter the soffit vent.
 - Install termination such that exhaust and rising moisture will not collect under eaves. Discoloration to the exterior of the building could occur if installed too close.
 - DO NOT install the vent termination too close under the soffit where it could present recirculation or exhaust gases back into the combustion air intake part of the termination.

Maximum equivalent vent lengths:

DO NOT exceed the maximum equivalent vent lengths.



Maximum equivalent vent lengths are specific to the fuel type of the tankless water heater and the diameter of the vent pipe. It is imperative when performing vent length calculations that the following be taken into consideration.

Vent Type	Natural Gas Maximum equivalent vent length.	Propane Gas Maximum equivalent vent length.
3" PVC/CPVC	65 feet	41 feet
4" PVC/CPVC	100 feet	65 feet
Concentric PP	65 feet	41 feet
Two Pipe PP (Centrotherm)	41 feet	41 feet

Determining Vent Lengths / Components:

- **There are two methods that can be used to determine the vent lengths/components necessary for the installation:**
 - Option 1:** The installer can use the vent length calculation sheet provided in the twin pipe venting guide, filling in the quantity of the vent components (elbows, termination) plus the length of straight pipe in order to calculate the total equivalent vent lengths (a blank copy of the Vent Length Calculation Sheet is located in the back of the Twin Pipe Venting Guide).
 - Option 2:** The installer can use the maximum vent length tables (also in the twin pipe venting guide) to determine the maximum length of straight pipe that can be used with a specific termination type and quantity of elbows.
- **For these calculations each elbow or termination will reduce the maximum vent length by a specified amount:**
 - 2.5 feet for every 45° elbow.
 - 5 feet for every 90° elbow.
 - For terminations refer to table 10 in the venting guide for the vent length reduction specific to that type termination (also listed at the end of this presentation).

Example, Option 1, Equivalent Vent Length Calculation Sheet:

OPTION 1:

Calculation of equivalent piping lengths for venting system:

Choose the vent type and fill out the Table 3 below. When determining equivalent combustion air and vent length, add 5 feet for each 90° elbow, 2.5 feet for each 45° elbow.

Example of calculation (assume 3" diameter pipes for natural gas unit):

- Twin pipe (parallel) with snorkel terminal
- Combustion air pipe length: 40 ft straight pipe with 3 x 90° elbows
- Exhaust pipe length: 40 ft straight pipe with 3 x 90° elbows (include all interior and exterior elbows)
- Snorkel Termination: 10 equivalent feet (reference Table 10 of this document)

Table 3: Equivalent Vent Length Calculation Sheet

	Fitting / Termination Type	Number of fittings		Equivalent Vent Length	=	Total Equivalent Length
1)	90 elbow	3	x	5	=	15
2)	45 elbow		x	2.5	=	0
3)	IPEX Low Profile Termination		x	5	=	0
4)	IPEX 4" Concentric Termination		x	20	=	0
5)	IPEX 3" Concentric Termination		x	20	=	0
6)	3" Tee Termination		x	5	=	0
7)	4" Tee Termination		x	5	=	0
8)	3" Snorkel Termination	1	x	10	=	10
9)	4" Snorkel Termination		x	10	=	0
10)	Length of Straight Section in feet	NA		40	=	40
				Total (add up lines 1 through 10)		65

Example, Option 2, Equivalent Vent Length Calculation Sheet:

OPTION 2: Maximum Equivalent Vent Length Tables:

1. Determine the number of 90 degree elbows in the vent system. (two 45 degree elbows count as one 90 degree elbow.)
2. Refer to Tables 4-7 to find the maximum vent length based on the number of elbows and termination style.

Table 4 - Natural Gas Units				
Total Equivalent Vent Length (Intake/outlet) for Twin Pipe 3" PVC/CPVC				
Maximum Vent Length	65 Feet			
Termination Type	IPEX Concentric Vent Kit	Snorkel Termination	Side Wall Tee Termination	Low Profile Termination
Termination Equivalent Length in feet (meters) (Already factored into the straight pipe lengths below)	20 (6.1)	10 (3.0)	5 (1.5)	5 (1.5)
# of 90° Elbows (each: 5 equivalent feet)	Max. straight pipe vent length in feet (meters)			
0	45 (13.7) **	55 (16.8) **	60 (18.3) **	60 (18.3) **
1	40 (12.2) **	50 (15.2) **	55 (16.8) **	55 (16.8) **
2	35 (10.7) **	45 (13.7) **	50 (15.2) **	50 (15.2) **
3	30 (9.1) **	40 (12.2) **	45 (13.7) **	45 (13.7) **
4	25 (7.6) **	35 (10.7) **	40 (12.2) **	40 (12.2) **
5	20 (6.1) **	30 (9.1) **	35 (10.7) **	35 (10.7) **
6	15 (4.6) **	25 (7.6) **	30 (9.1) **	30 (9.1) **

Twin Pipe Adaptor Installation:

- **When installing the Ubbink adaptor with the two pipe PVC/CPVC system:**
 - Install the system according to Ubbink/Rolux and Rinnai installation instructions.
 - Use the 3"/5" Concentric-to-Twin Pipe adaptor with 3" or 4" diameter PVC/CPVC venting only.
 - Follow all instructions related to inspection, securing, lubrication and assembly of the adaptor and the vent components.
 - It is the responsibility of the installer to follow all national codes, standards and local ordinances in addition to the instructions laid out in this manual for vent/intake clearances and other safety requirements.
 - If venting conflicts arise between this guide and the respective OEM's manual, the OEM's manual, the manufacturers' installation instructions will take precedence providing they meet the intent of all national codes, standards and local ordinances having jurisdiction. Follow the installation guide together with applicable codes, standards and/or ordinances for installation of the intake/vent pipe(s) and all other applicable water heater installation procedures.

Adapter installation examples:

Twin Pipe Adaptor installation examples for 3" and 4" venting.

Components shown below the dashed line in each example are included with the adaptor.

Components shown above the dashed line are field supplied.

Utilizing the adaptor with 3" vent materials.

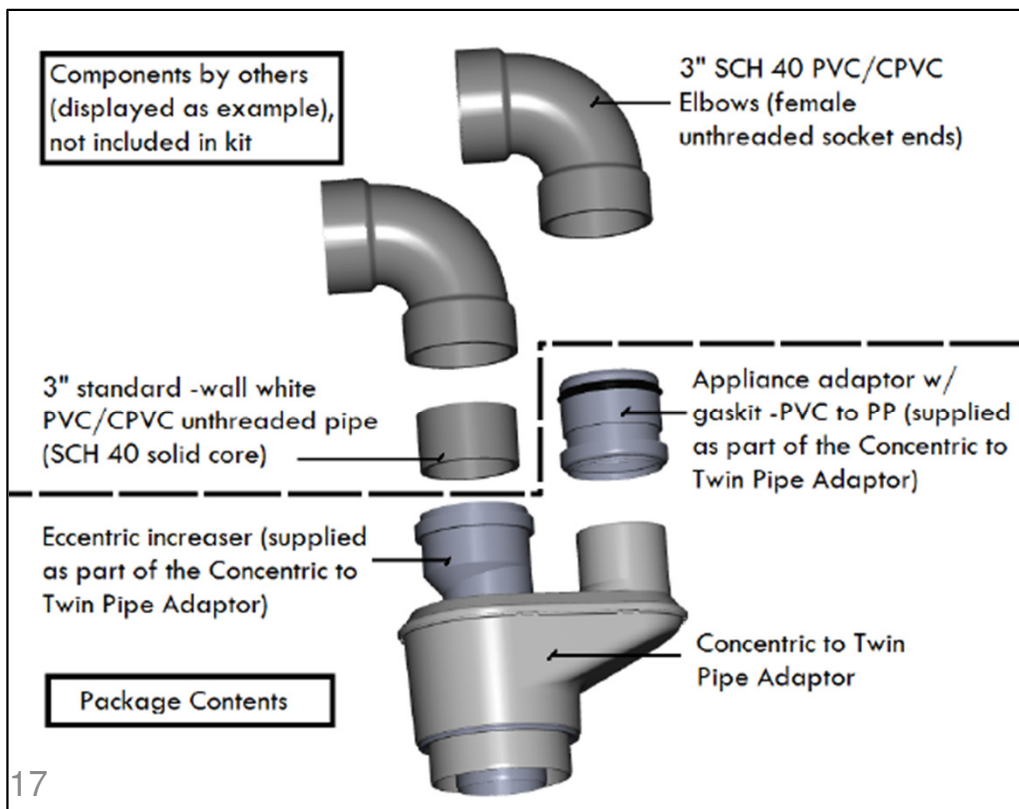

Utilizing the adaptor with 4" vent materials.

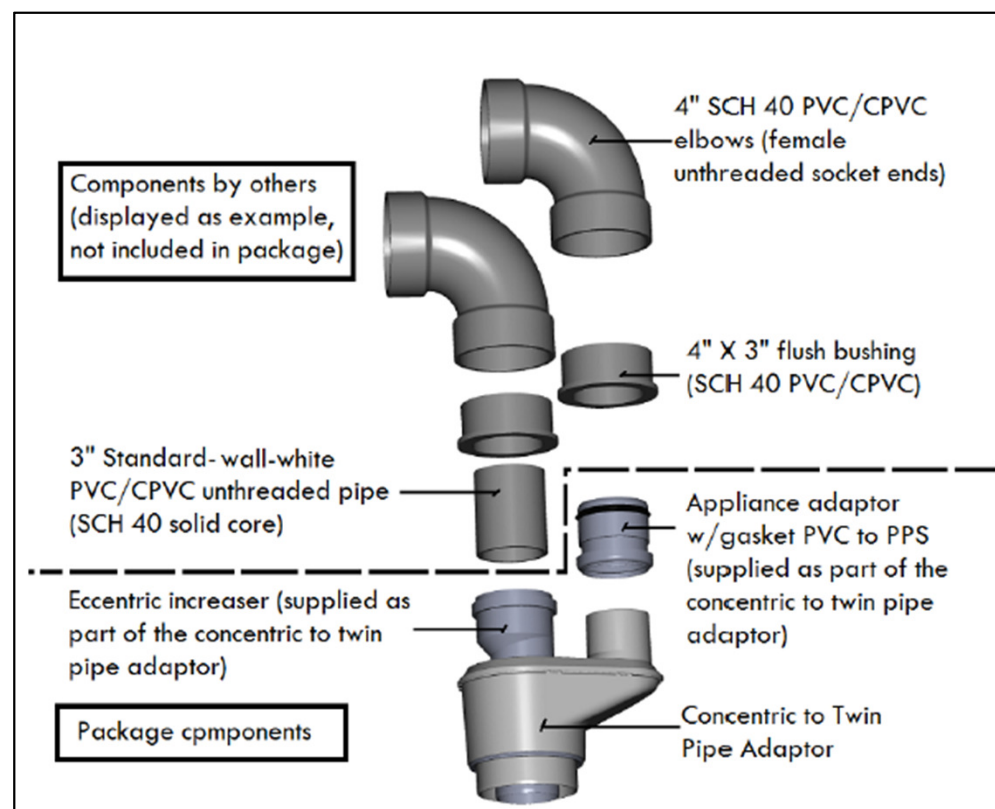

Vent Termination:

Vent Termination Configurations:

1. Concentric Termination (IPEX Concentric Vent Kit):
 - Allows for one penetration through a wall or roof. The IPEX termination can be used vertically or horizontally (available in 3" and 4" sizes).
2. Two Pipe Termination:
 - Two penetrations through the roof or wall. This configuration allows for easier clearance above grade or snow level by extending the piping as necessary (within the maximum equivalent vent length limits). Also a low profile two-pipe sidewall termination is available (3" & 4").

IPEX
Concentric
Termination.
Can be used
vertically or
horizontally.

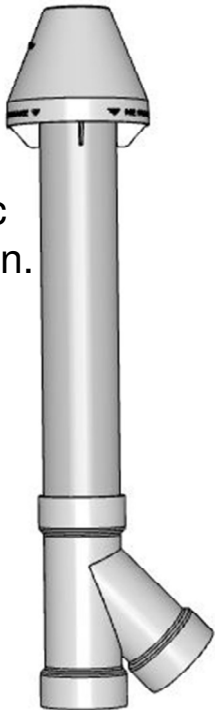

Snorkel
Termination.

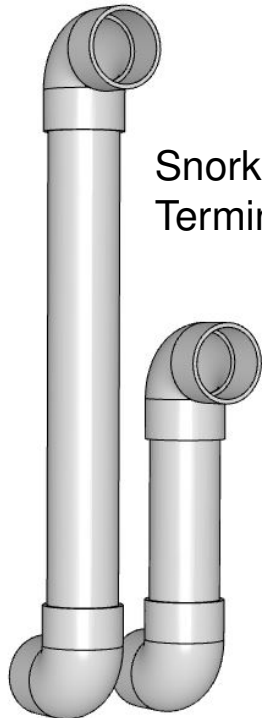

Sidewall Tee
Termination.

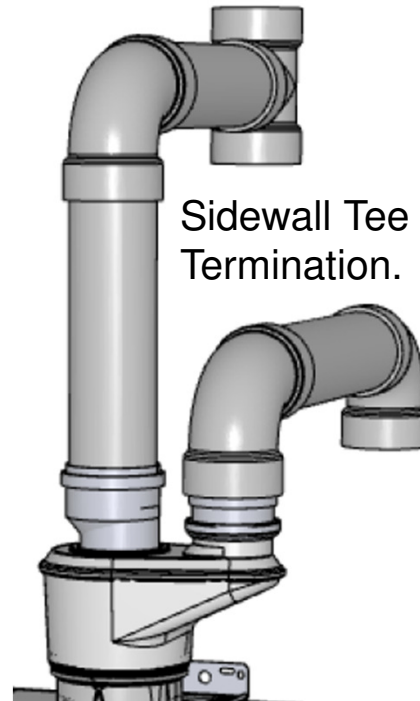

Low Profile
Termination.

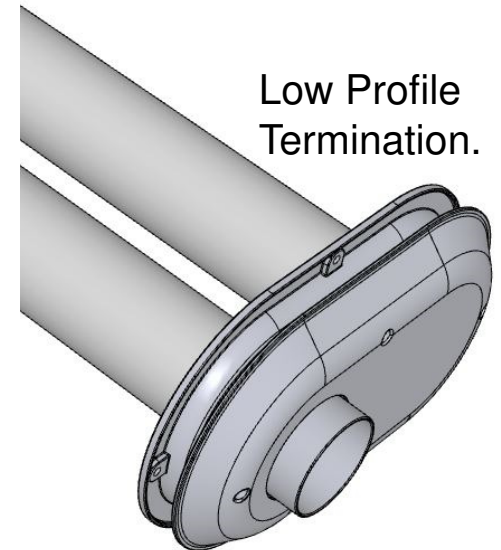

Rinnai®

Vent Termination (cont.):

Vent termination vent length equivalents				
Termination Type	IPEX Concentric Vent Kit	Snorkel Termination	Sidewall Tee Termination	Low Profile Termination
Termination Equivalent Length in feet (meters)	20 (6.1)	10 (3.0)	5 (1.5)	5 (1.5)
<p>The termination equivalent lengths above are to be subtracted from the maximum vent length allowed (for your gas type and vent diameter) in order to calculate the remaining vent length that can be utilized by elbows and straight vent pipe sections (see vent length tables in the venting guide).</p>				

Termination Installation:

- Vent and air piping must be securely fastened to structure.
- Support straps are field supplied. Use straps or clamps that will not damage the pipe. Expansion and contraction should be addressed between the appliance and termination point.
- All penetrations must be sealed according to local building codes. Caulking for sidewall terminations and flashing for roof terminations are typical. Use only PVC/CPVC compatible sealing materials.
- The weight of the combustion air and/or vent pipes must be supported by the clamps/straps and not by the vent system it is connected to.

Rinnai[®]

Termination examples:

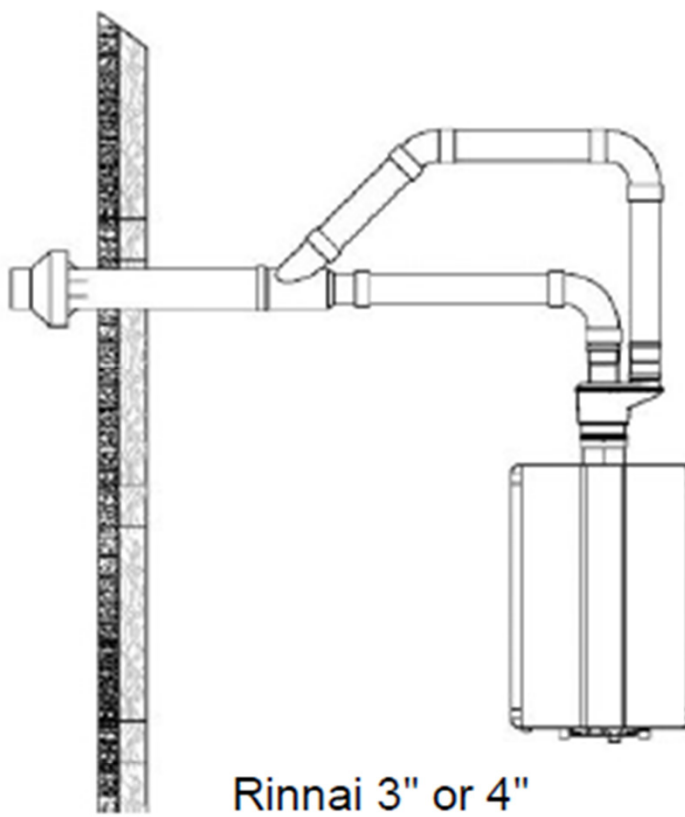

Rinnai 3" or 4"
PVC/CPVC
Concentric
Side Wall
Termination
Configuration

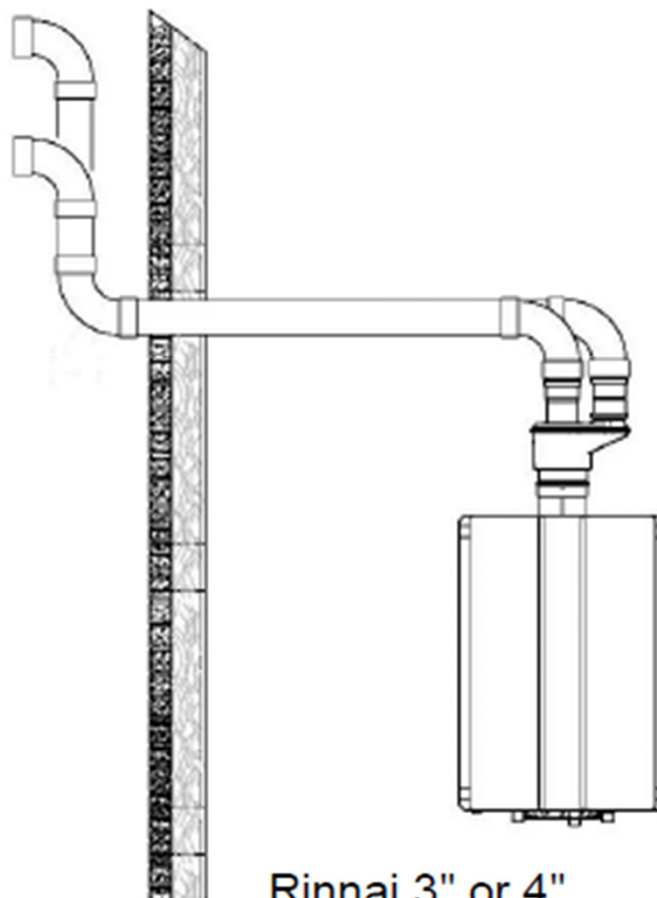

Rinnai 3" or 4"
PVC/CPVC
Snorkel
Termination
Configuration

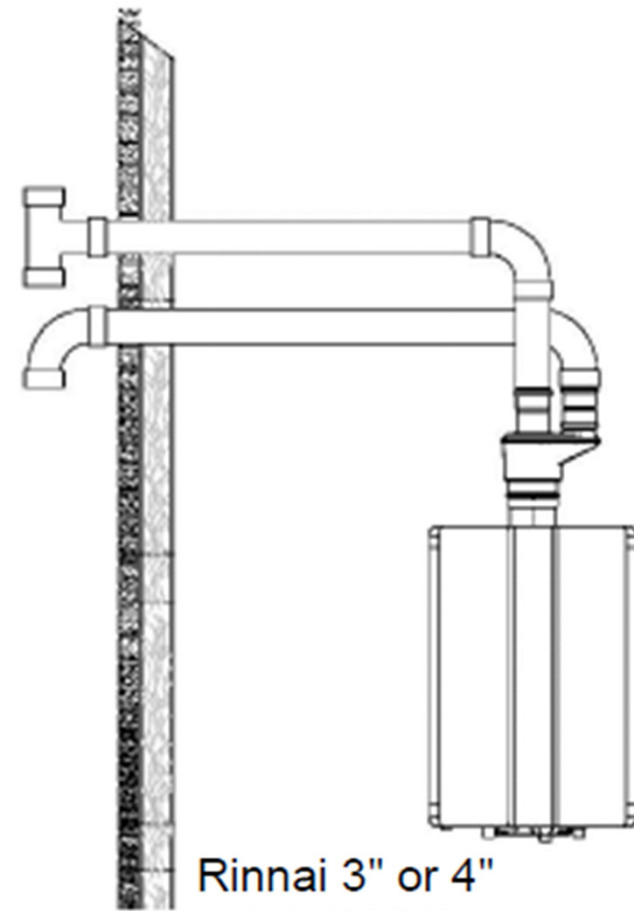

Rinnai 3" or 4"
PVC/CPVC
Tee Side Wall
Termination
Configuration

Rinnai®

Termination examples (cont.):

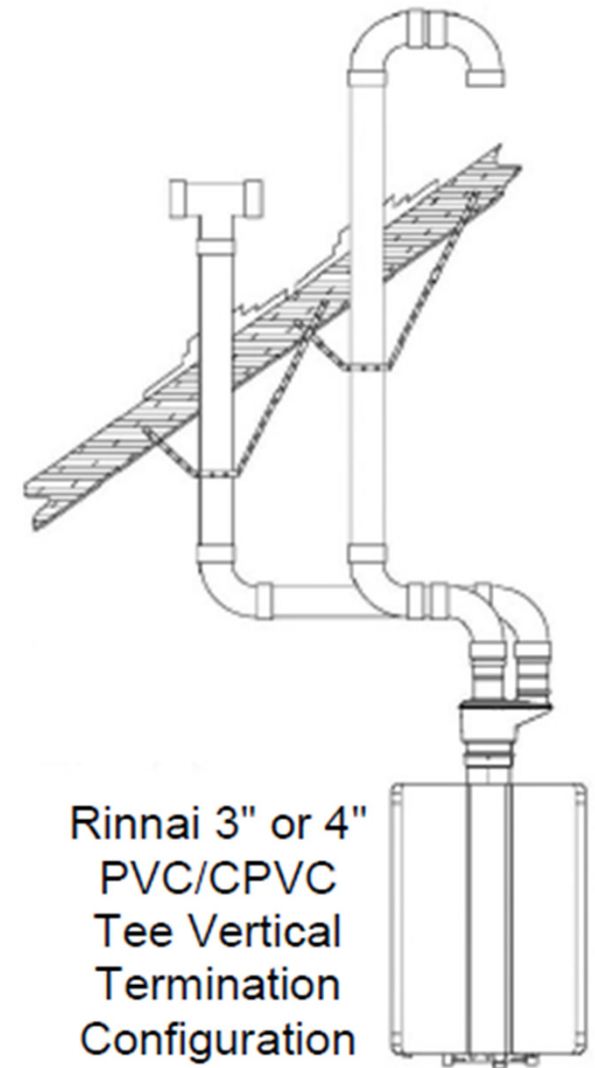
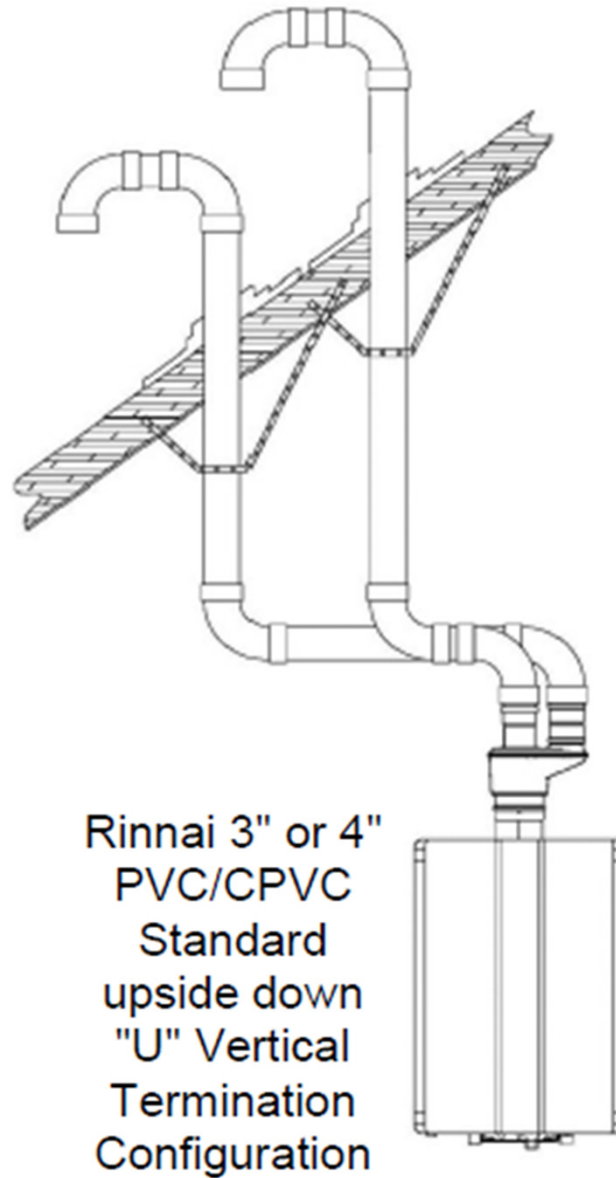
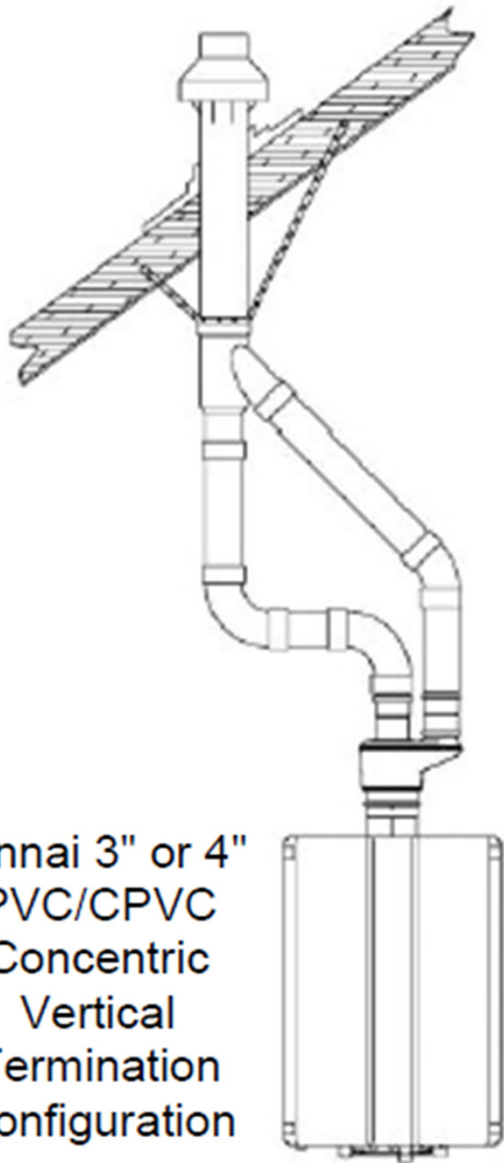

Rinnai[®]

Termination examples (cont.):



Rinnai 3" or 4"
PVC/CPVC
Low Profile
Termination
Configuration

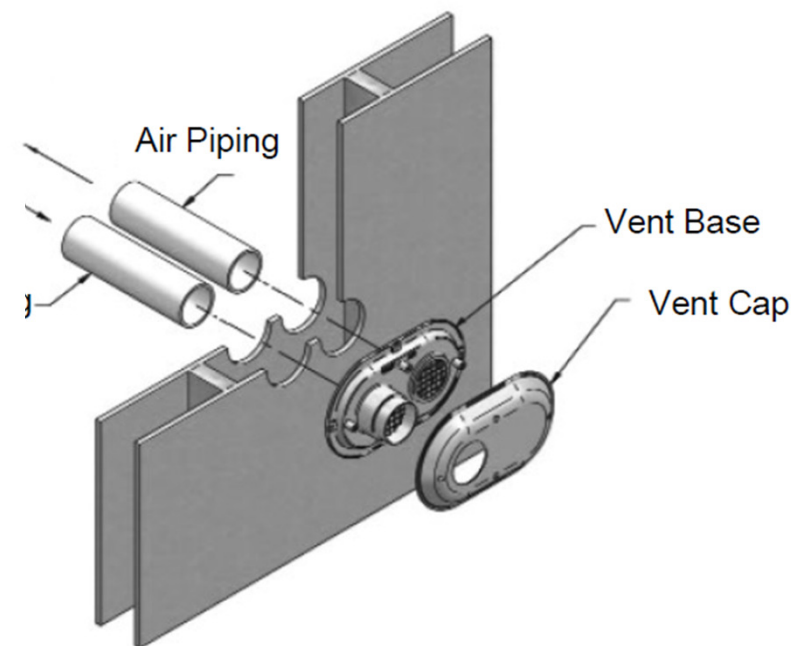
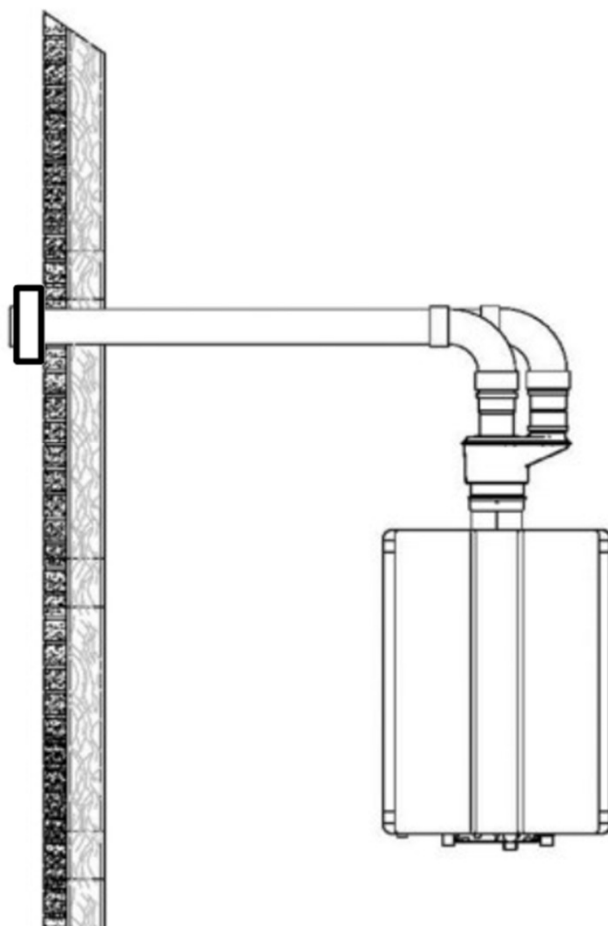

Terminal clearances:

IPEX Concentric Vent clearances:

- For multiple concentric terminations, see following page.

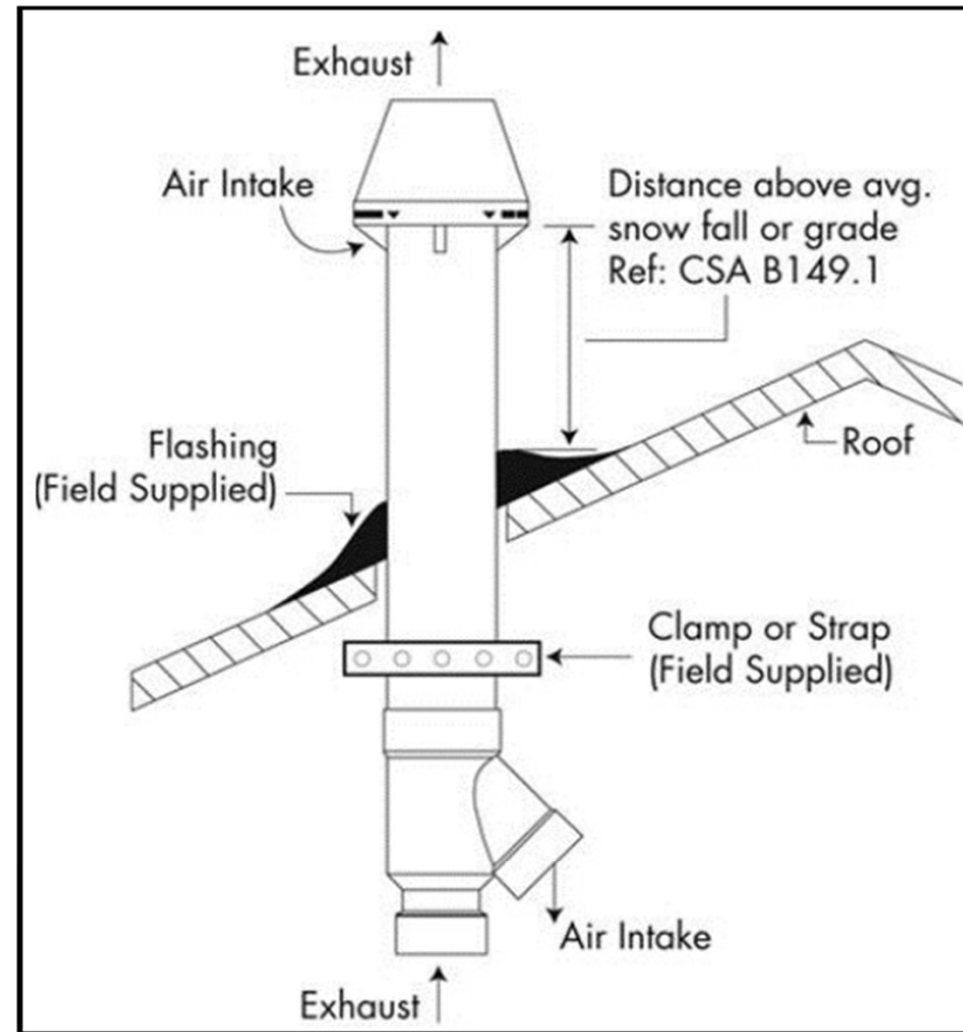
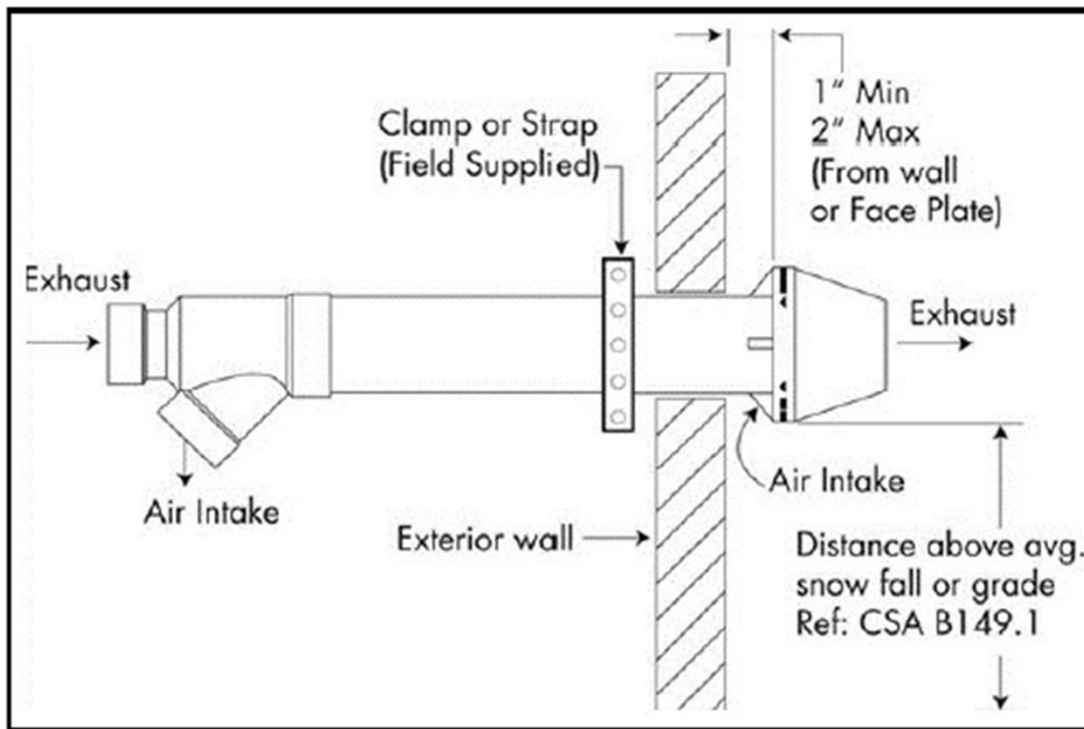

Rinnai

Terminal clearances (cont.):

Multiple IPEX Concentric Terminal clearances:

These clearances are for the IPEX terminals only. Other termination types may have different clearance requirements.

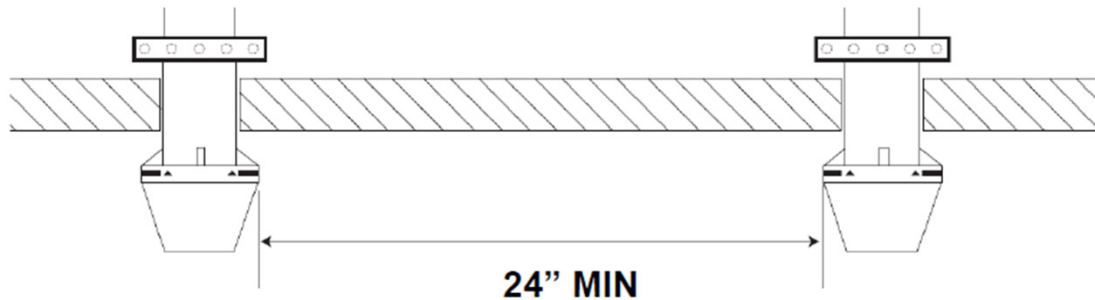

Horizontal sidewall terminations, shown looking down from above. For more than two horizontal terminations, on the same plane, maintain the same 24" minimum clearance side to side.

Horizontal sidewall terminations shown from the side with one terminal above the other.

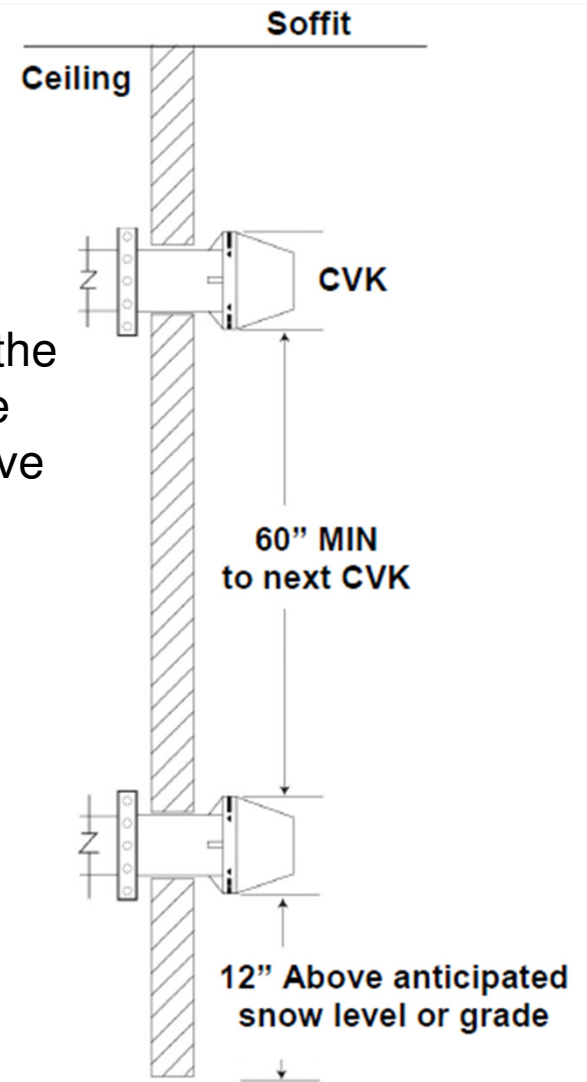

Rinnai

Terminal clearances (cont.):

Sidewall Tee and Snorkel termination clearances.

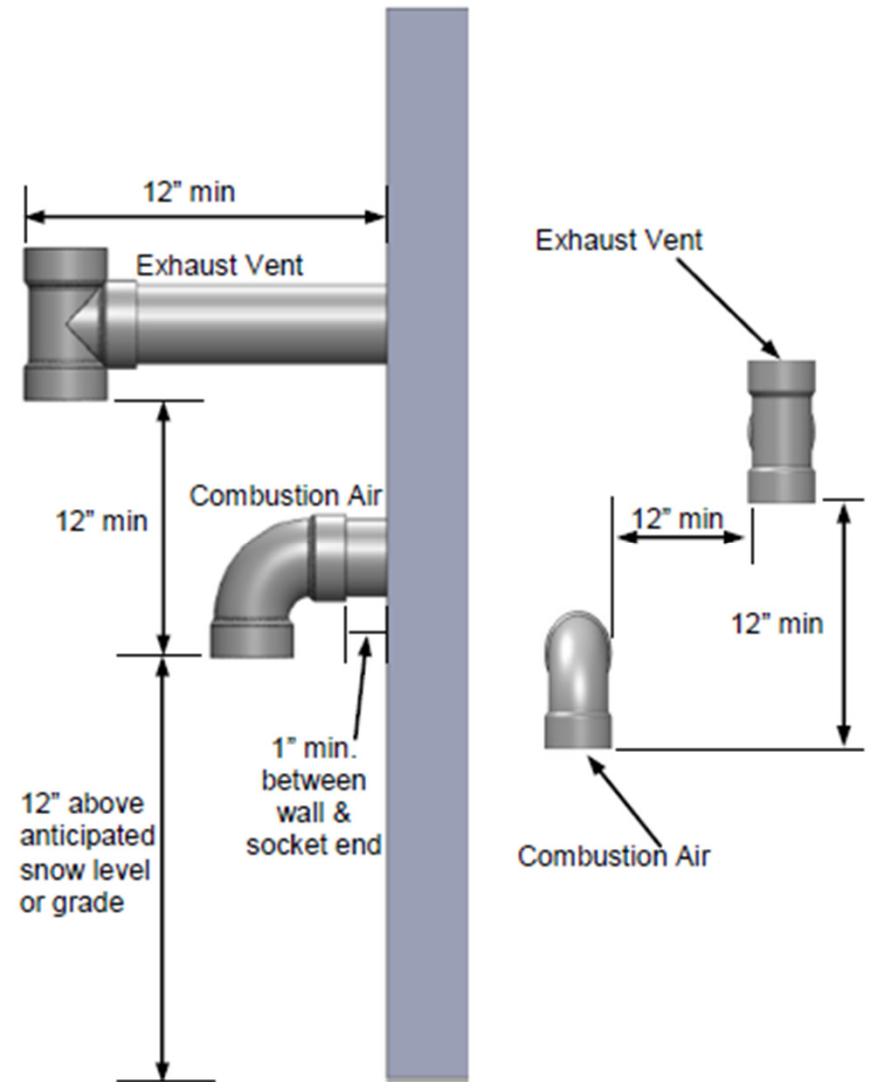
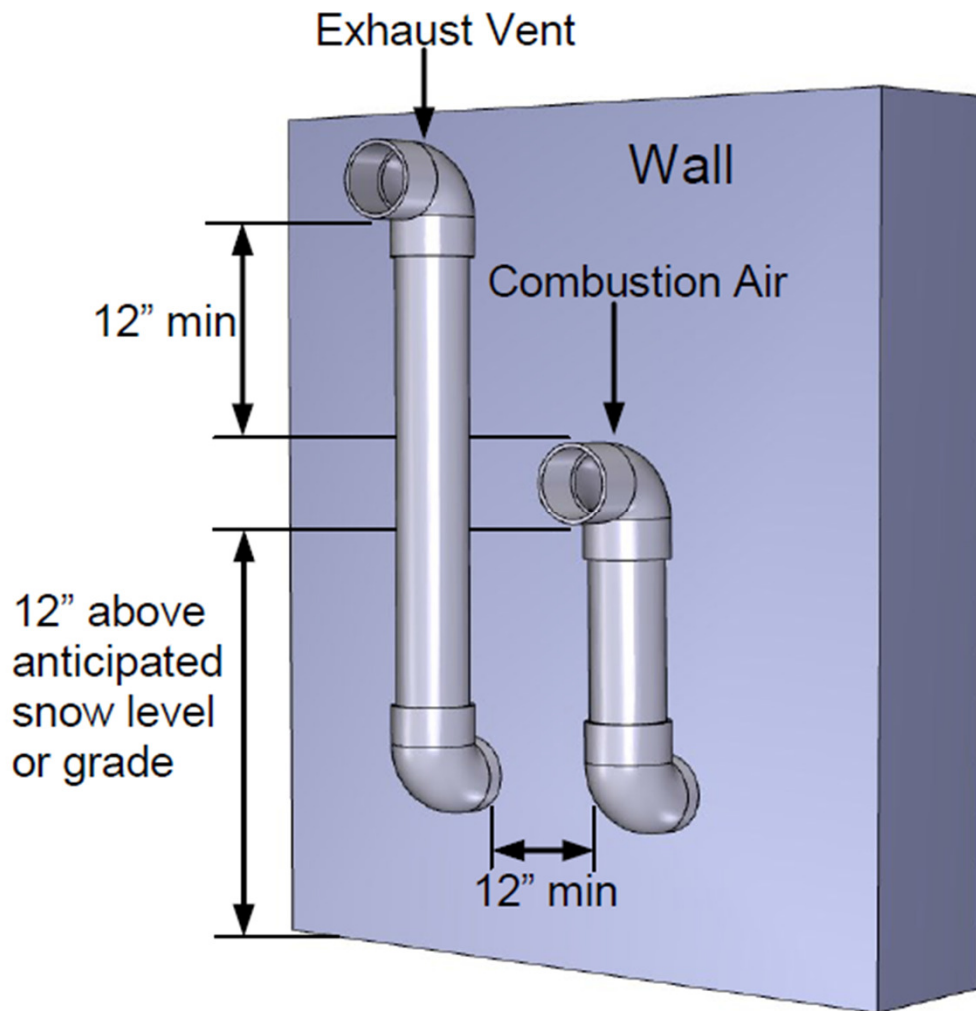

Rinnai

Terminal clearances (cont.):

Roof Tee and U-Vent Terminations (flat roof).

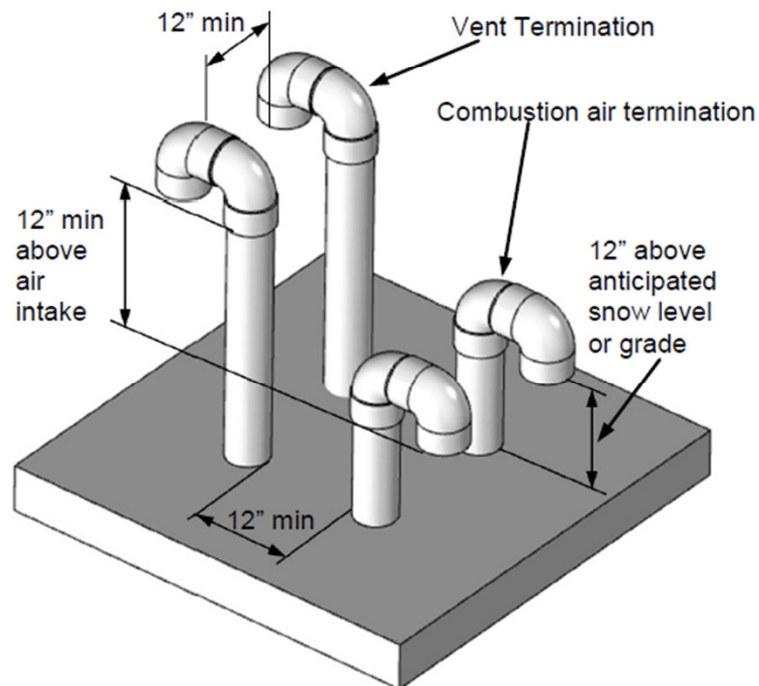
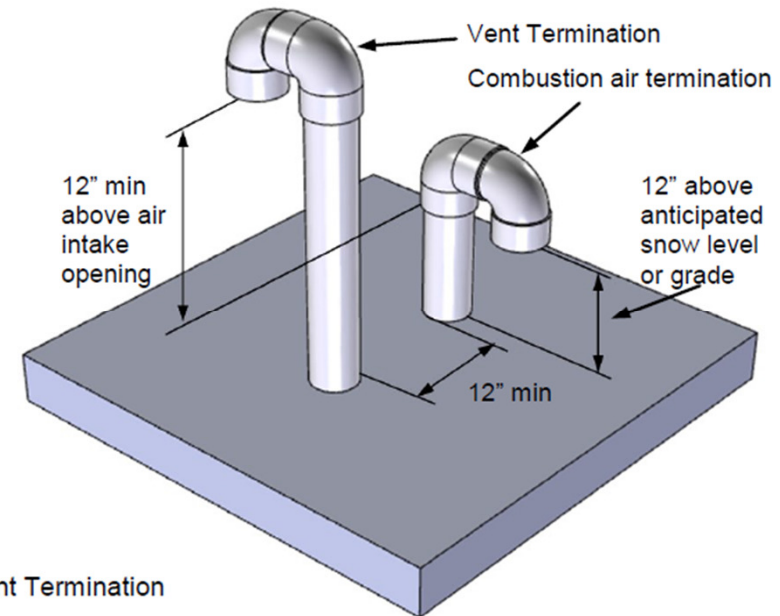
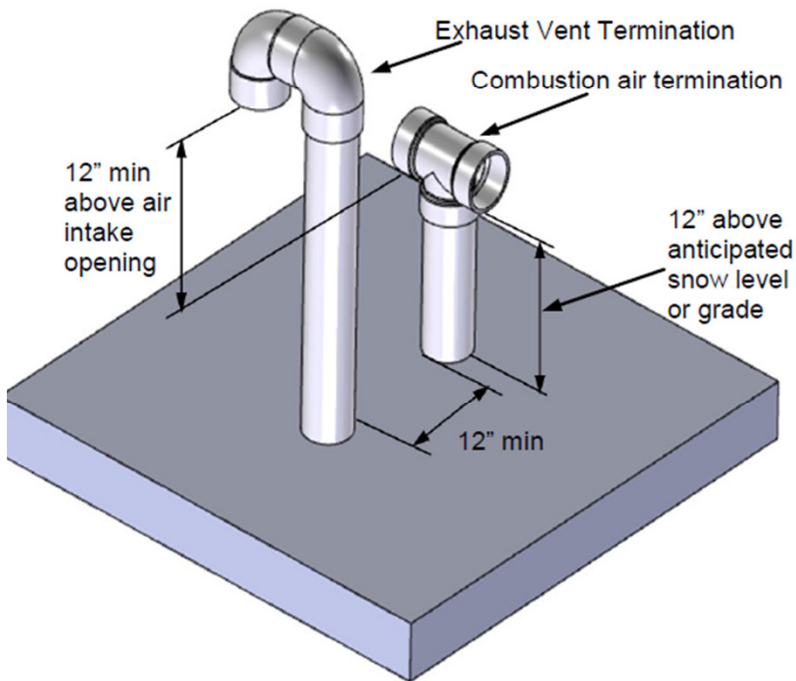

Terminal clearances (cont.):

Roof Tee and U-Vent Terminations (pitched roof).

Pitched Roof Termination Clearances:

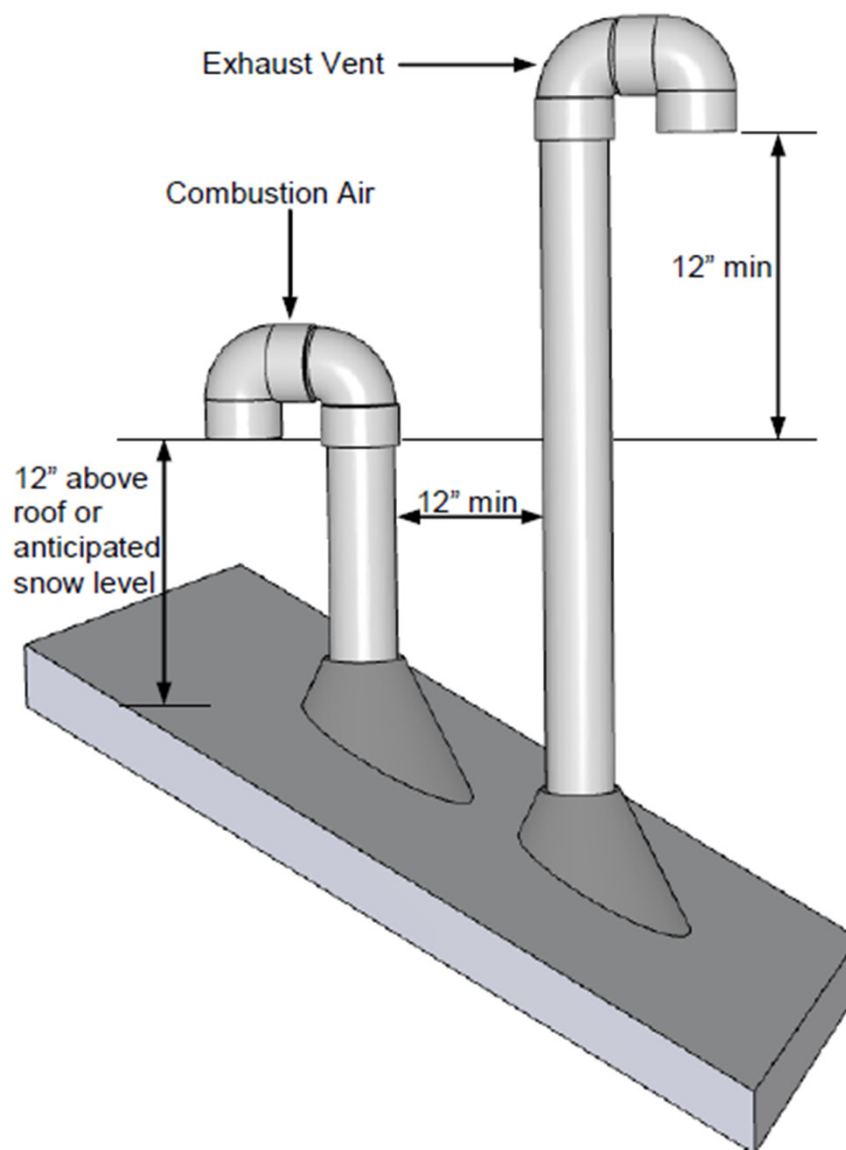

Rinnai[®]

Twin pipes with low profile termination.

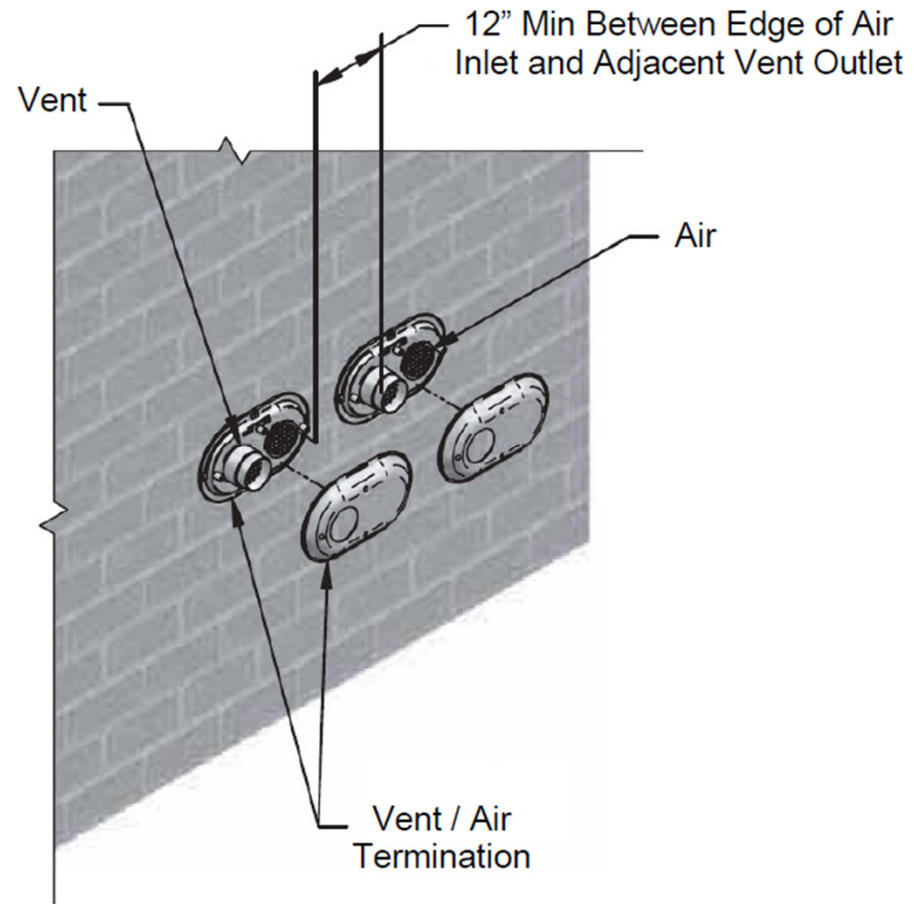
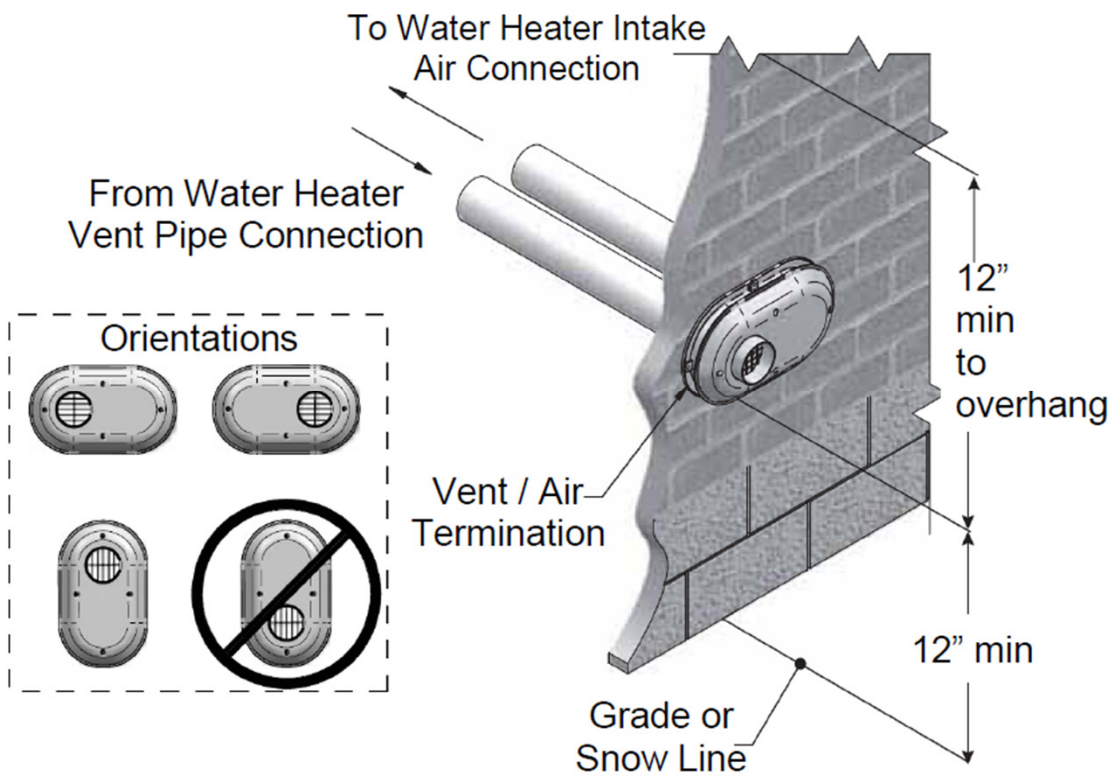



Vent parts information:

Approved PVC/CPVC Vent Components.

Manufacturer	OEM P/N or Cert.#	Product Description	Diagram	Equivalent Lengths (ft.)
IPEX (purchased separately)	196006 / 197009 (3") 196021 / 197021 (4") (system 636).	PVC/CPVC – FGV Concentric 4" or 3" Vent Kit w/Vent Screen		20
IPEX (purchased separately)	196985 (3"), 196986 (4") (system 636)	Low Profile Termination Kit		5
Field Supplied PVC/CPVC Sch. 40 fittings or approved equiv.	Comply with CAN/CGA B149.1 & ULC-S636	3" and 4" Sch. 40 (Solid core) PVC/CPVC TEE w/vent screen.		5
Field Supplied PVC/CPVC Sch. 40 fittings or approved equiv.	Comply with CAN/CGA B149.1 & ULC-S636	3" and 4" Sch. 40 (Solid core) PVC/CPVC 90° EL w/vent screen.		5
Field Supplied PVC/CPVC Sch. 40 fittings or approved equiv.	Comply with CAN/CGA B149.1 & ULC-S636	3" and 4" Sch. 40 (Solid core) PVC/CPVC 45° EL w/vent screen.		2.5
IPEX (purchased separately)	196051 & 196052	Friction fit vent screen (3" and 4" respectively)		0
Field Supplied PVC/CPVC Sch. 40 fittings or approved equiv.	Comply with CAN/CGA B149.1 & ULC-S636	3" and 4" Sch. 40 (Solid core) PVC/CPVC Snorkel vent w/vent screen.		10

Vent parts information (cont.):

Types of PVC elbows allowed and not allowed in the venting system.		
Acceptable	Acceptable	NOT Acceptable
90° Elbows, Female, Unthreaded socket ends: (Long Turn) Long Sweep	90° Elbows, Female, Unthreaded socket ends: (1/4 bend) Short Sweep	90° Elbows, Female, Unthreaded socket ends: Close Turn-
		

- Vent screens are not ULC S636 Certified.
- Friction fit vent screens inside termination fitting to avoid debris and/or small animals from entering the vent.
- Primer shall be used when installing System 636 and other PVC / CPVC products at temperatures below 32°F.
- Primer is required in some jurisdictions regardless of temperature, verify with your local authority having jurisdiction.
- Use only System 636 cements and primers. Substituting other cements and primers will void IPEX's certification and warranty.
- For schedule 40 PVC/CPVC any glue and primer approved by your local authority having jurisdiction may be substituted.

Specifications for Twin Pipe Adaptor:

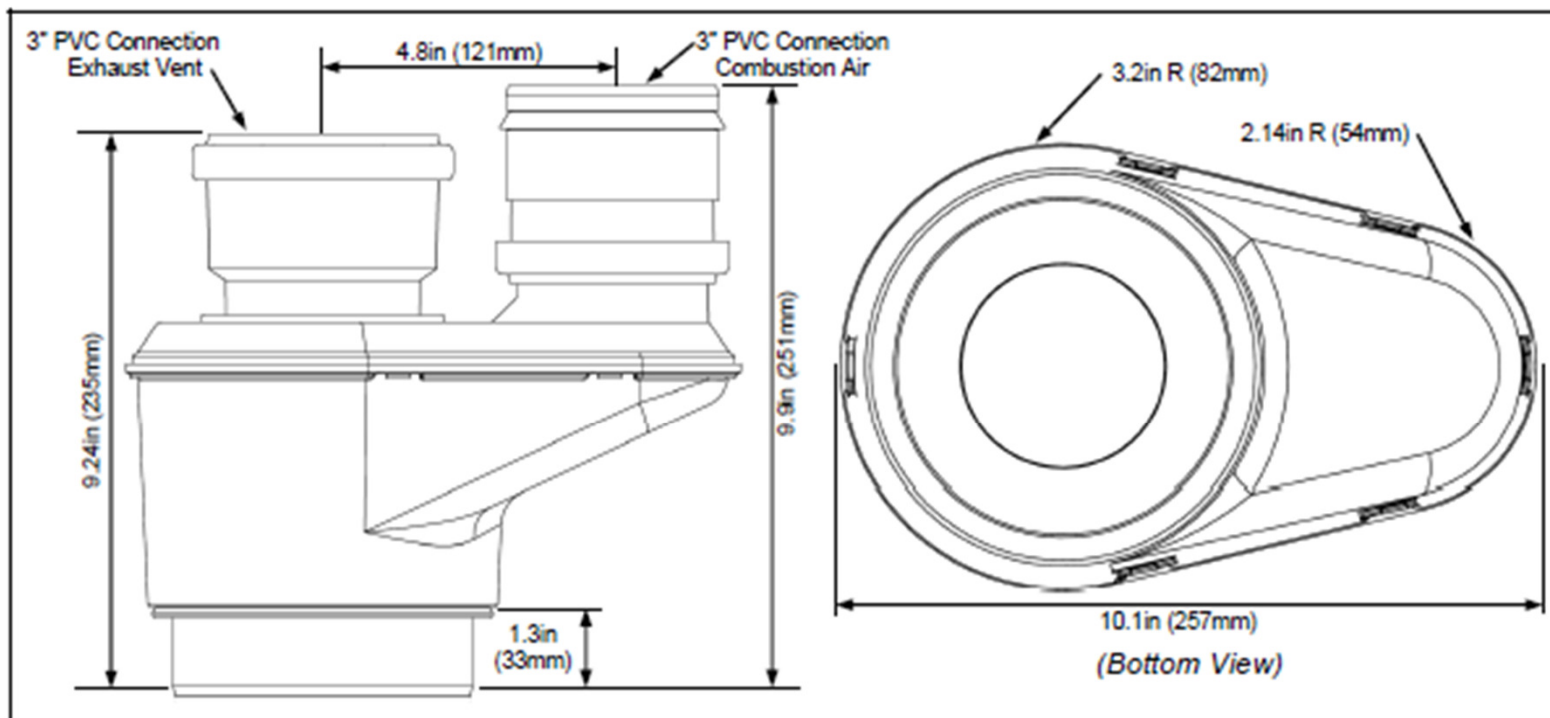

Physical Data in inches (mm)

Part #	Nominal Diameter	Overall Height	Effective Height	Offset
187585PP	3 ¹ / ₅ " (80/125)	9.9" (251)	8.6" (218)	4.8" (121)
Materials <ul style="list-style-type: none"> Exhaust: ULc S636-PPs (grey) Combustion Air Pipe: PPs (grey) Adapter: PVC (white) 		ULc 636 Gas Vent-BH Class IIC-110°C/230°F <i>where applicable</i>		
<p align="center">⚠ WARNING</p> <p>Improper installation of vent system and components, or failure to follow all installation instructions, can result in property damage or serious injury.</p>				

This concludes the Twin Pipe
PVC / CPVC Venting options
Presentation.