

Siemens Building Technologies, Inc.  
8 Fernwood Road  
Florham Park, New Jersey 07932

Siemens Building Technologies, Ltd.  
2 Kenview Boulevard  
Brampton, Ontario, Canada L6T 5E4

**Model DB-11/-11E**  
**(P/N 500-094151/500-094151E)**

## DETECTOR AND BASE PLACEMENT

Detector and base locations shall follow the drawings provided or approved by Siemens Building Technologies, Inc. or its authorized distributors. This is extremely important! The detector placements shown on these drawings were chosen after a careful evaluation of all facets of the protected area. When drawings are not available, refer to *Detector Placement* section of detector Installation/Wiring Instructions and to NFPA Standard 72 and CAN/ULC-S524.

## BASE WIRING

Siemens Building Technologies, Inc.'s detectors should be interconnected as shown in Figures 1, 2 or 3 and wired to the control panel following the wiring connection drawing installed on the inside face of each control panel cover. NOTE: H Series devices are wired to the DLC or FS-DLC; S Series devices are wired to the FDLC. **Note any limitations on the number of detectors and restrictions on the use of remote devices permitted for each circuit.**

## DETECTOR MOUNTING USING THE DB-11/-11E BASE

The detector is provided with a separate base which attaches to a standard 4 inch square, 4 inch octagonal, or single gang electrical box, with the box size and depth required by the NEC for the number and size of conductors used. Wire size: max – 14 AWG, min – 18 AWG.

### Refer to Figures 4 and 5, as applicable.

1. Route all wires outward from outlet box.
2. When ALARM LED viewing is critical, position the LED mark in the base in the intended direction.
3. Route wires through the hole in the center of the base and mount base to outlet box. Make connections directly to the base terminals. Refer to Figures 1, 2 and 3 for details.
4. After all bases are installed, check loop continuity. Refer to the System Manual for the loop continuity check procedure. To allow for the continuity check with PE-11, PE-11T or DT-11 detectors, use DBJ-11 Jumper Kit, P/N 500-699167 (between terminals 1a and 1b) to complete the loop. Do not use a jumper for FP-11/HFP-11/FS/SFP-11 family devices.
5. Continuity jumper must be removed from each base prior to installing detector.
6. To insure proper installation of the detector head into the base:
  - a. Route wires away from connector terminals.
  - b. Take up all slack in the outlet box.
  - c. Properly dress and position all wires flat against the base.
  - d. Check that screw terminals are tight.
7. (DB-11 only) Break off the two mounting hole covers, and insert in two outer base mounting holes.

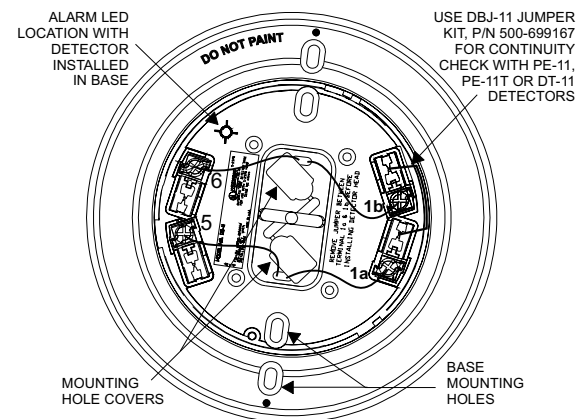

Figure 4  
Mounting The DB-11 Base

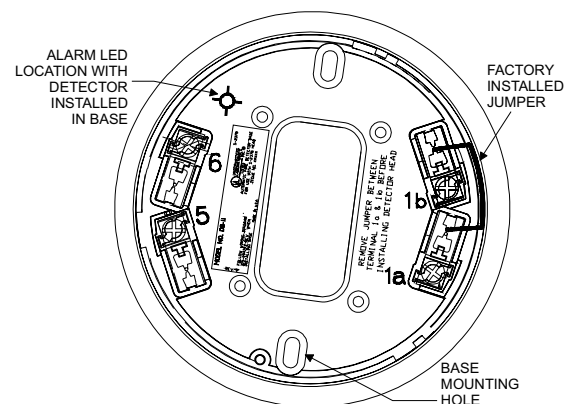

Figure 5  
Mounting The DB-11E Base