

**ARCHETYPE**  
architects  
48 Union Wharf Portland, Maine 04101  
(207) 772-6022 Fax (207) 772-4056

Date: 24 Oct 2013  
Scale: 1/2"=1'-0"  
**WALL  
ELEVATION**

Project: **145 COMMERCIAL  
STREET**  
COMMERCIAL STREET  
PORTLAND, ME

**A3.02**

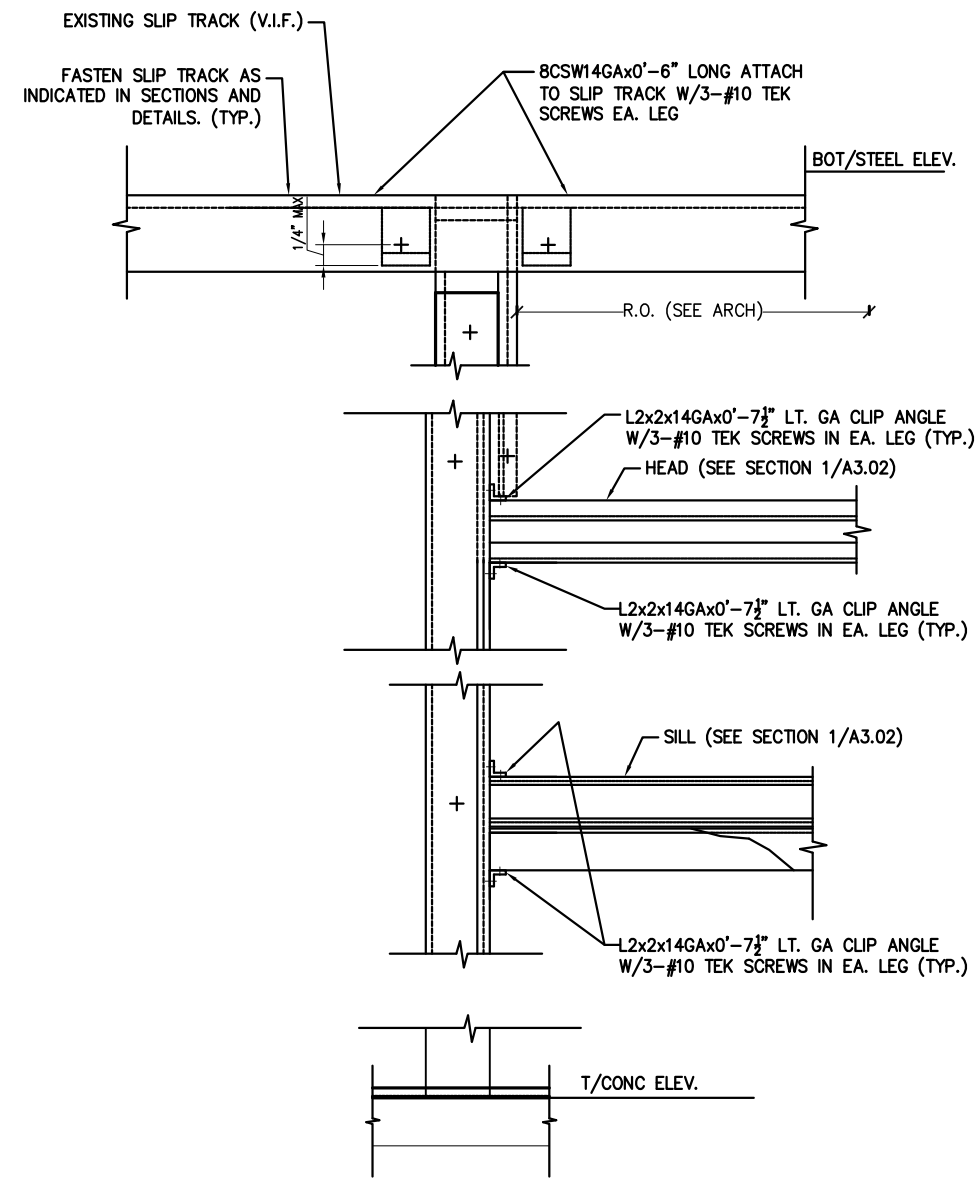

**A** | ELEVATION  
SCALE: 1/2"=1'-0"