

**C1** CANOPY SECTION  
1'-1'-0"

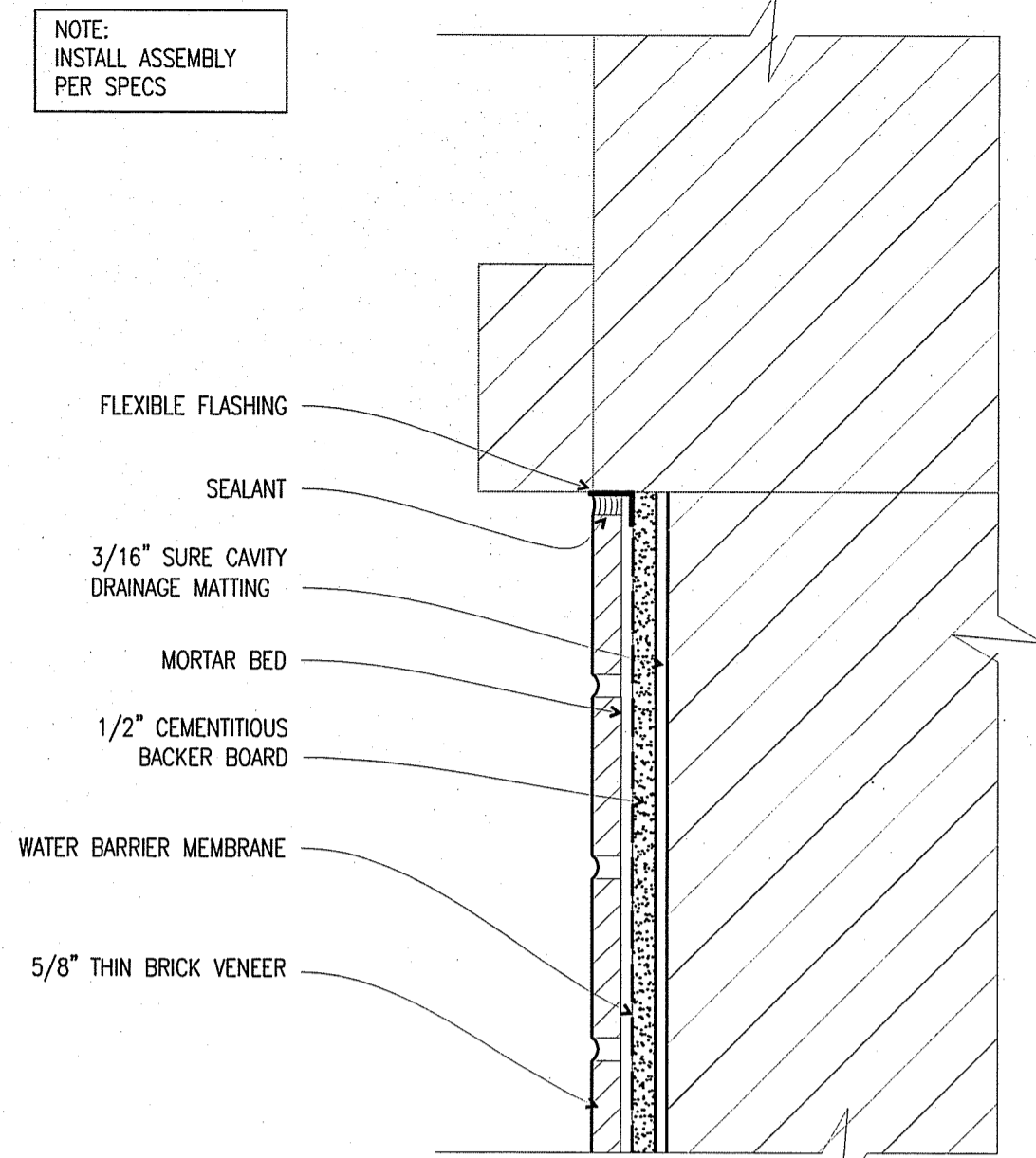

**C** CURVED HEAD / JAMB

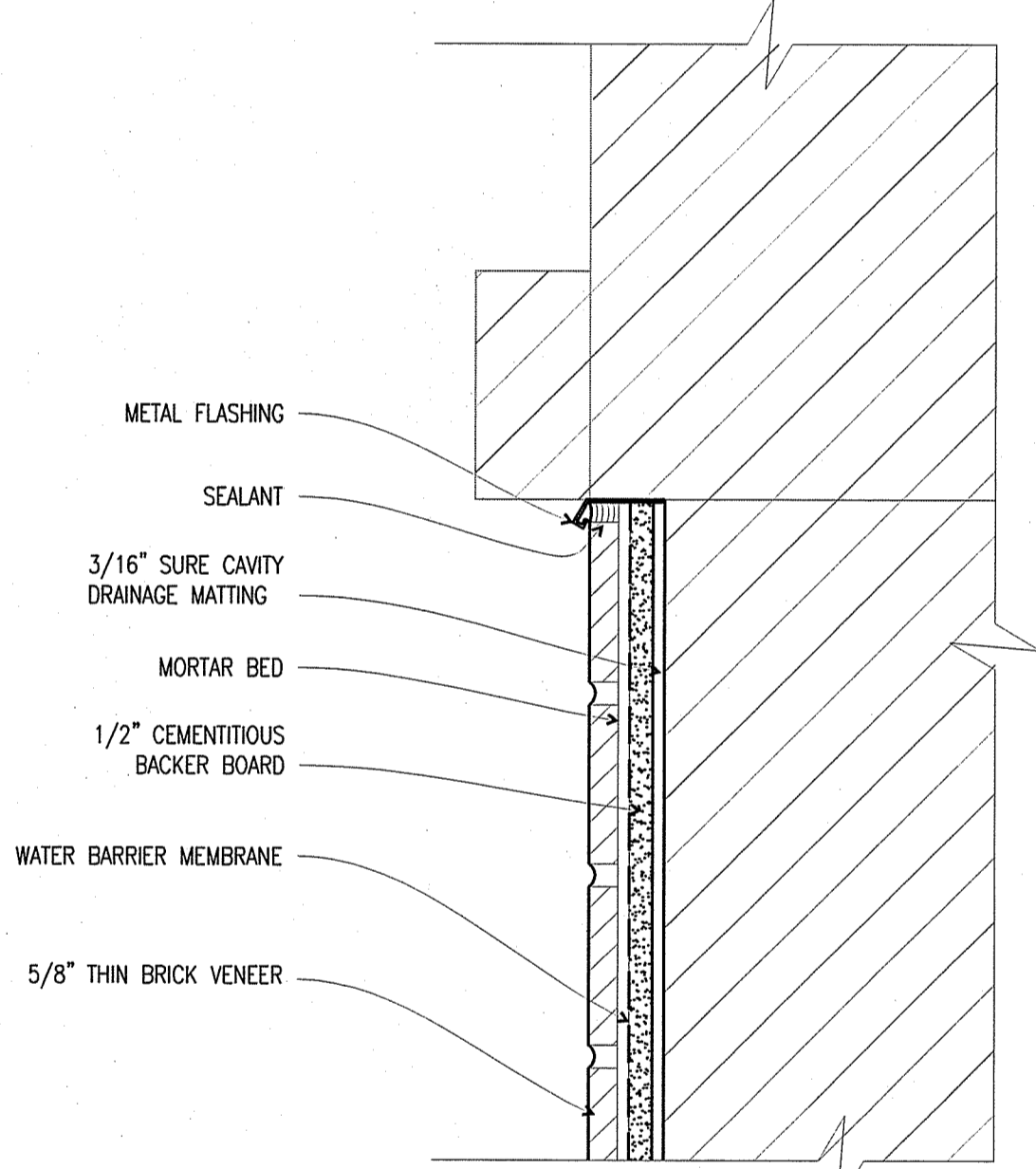

**B** FLAT HEAD

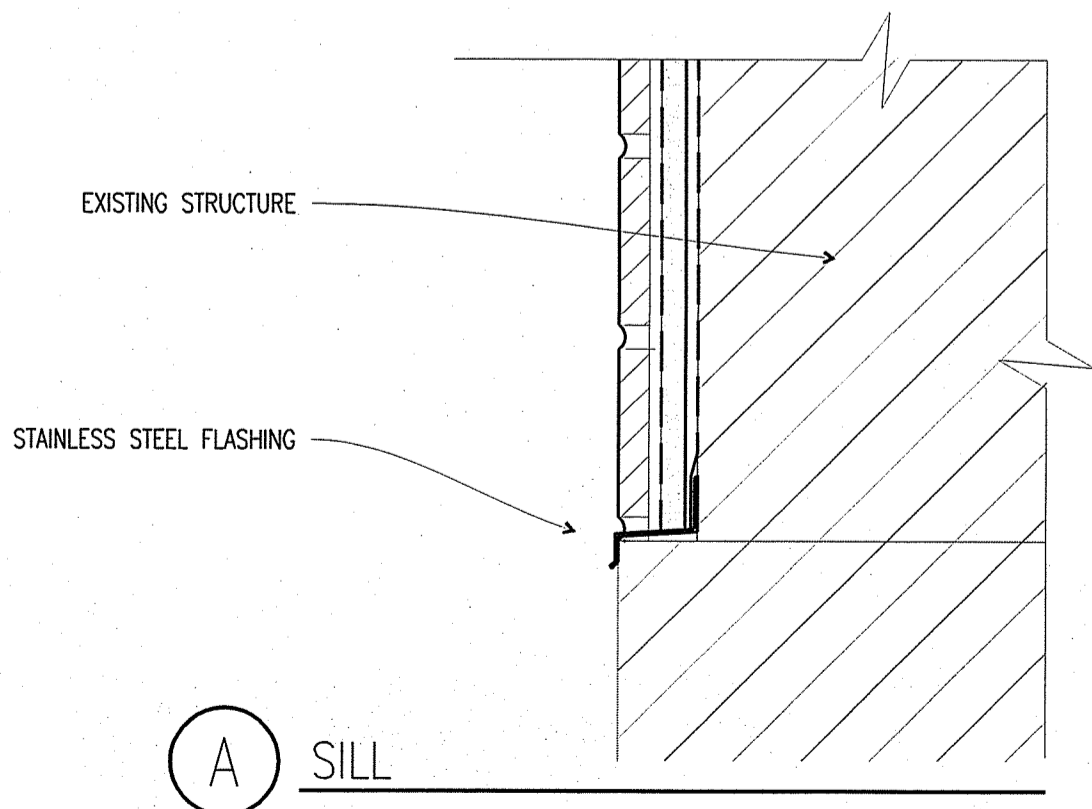

**A** SILL

**A9** THIN BRICK INFILL  
3'-1'-0"

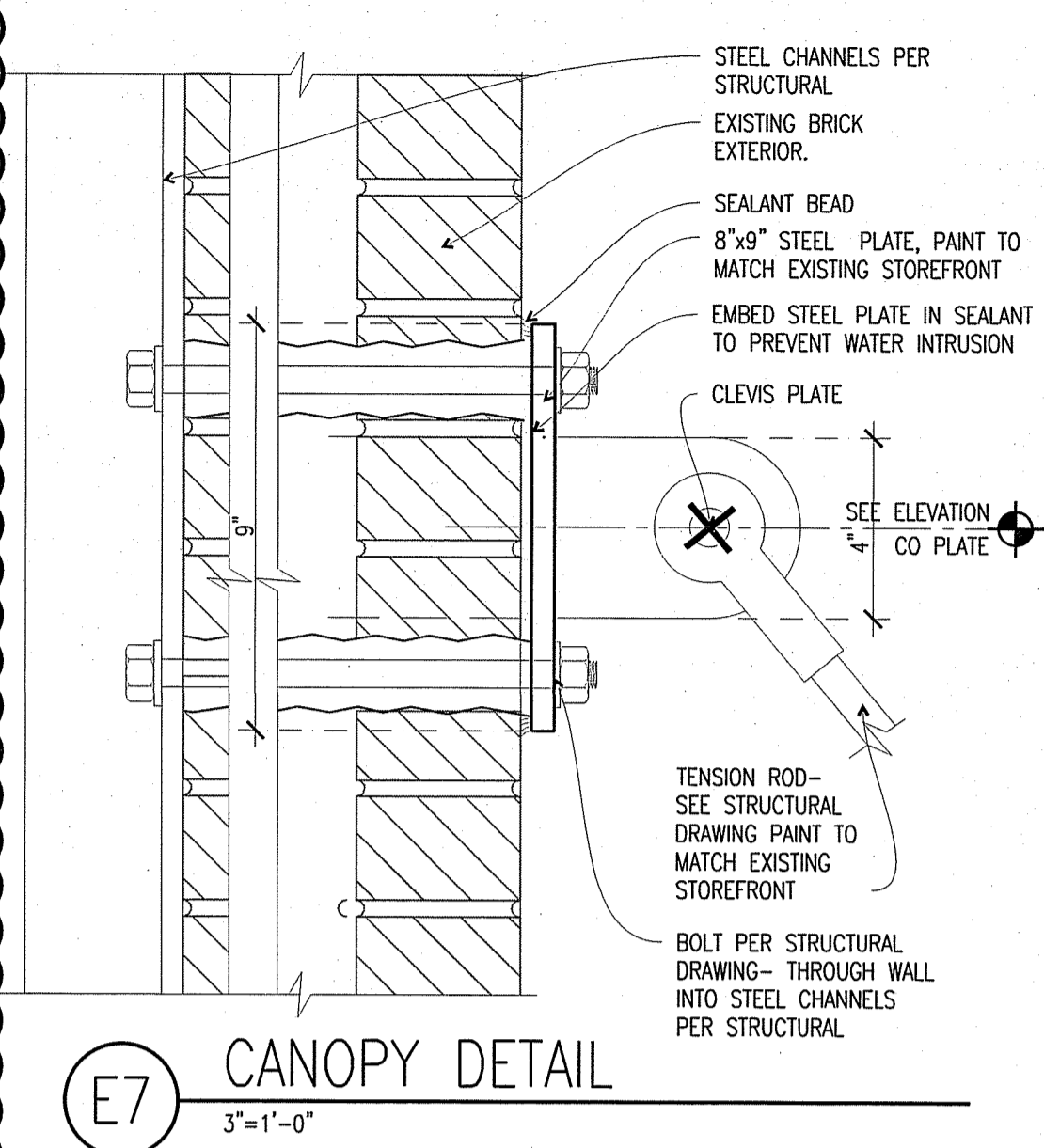

**E7** CANOPY DETAIL  
3'-1'-0"

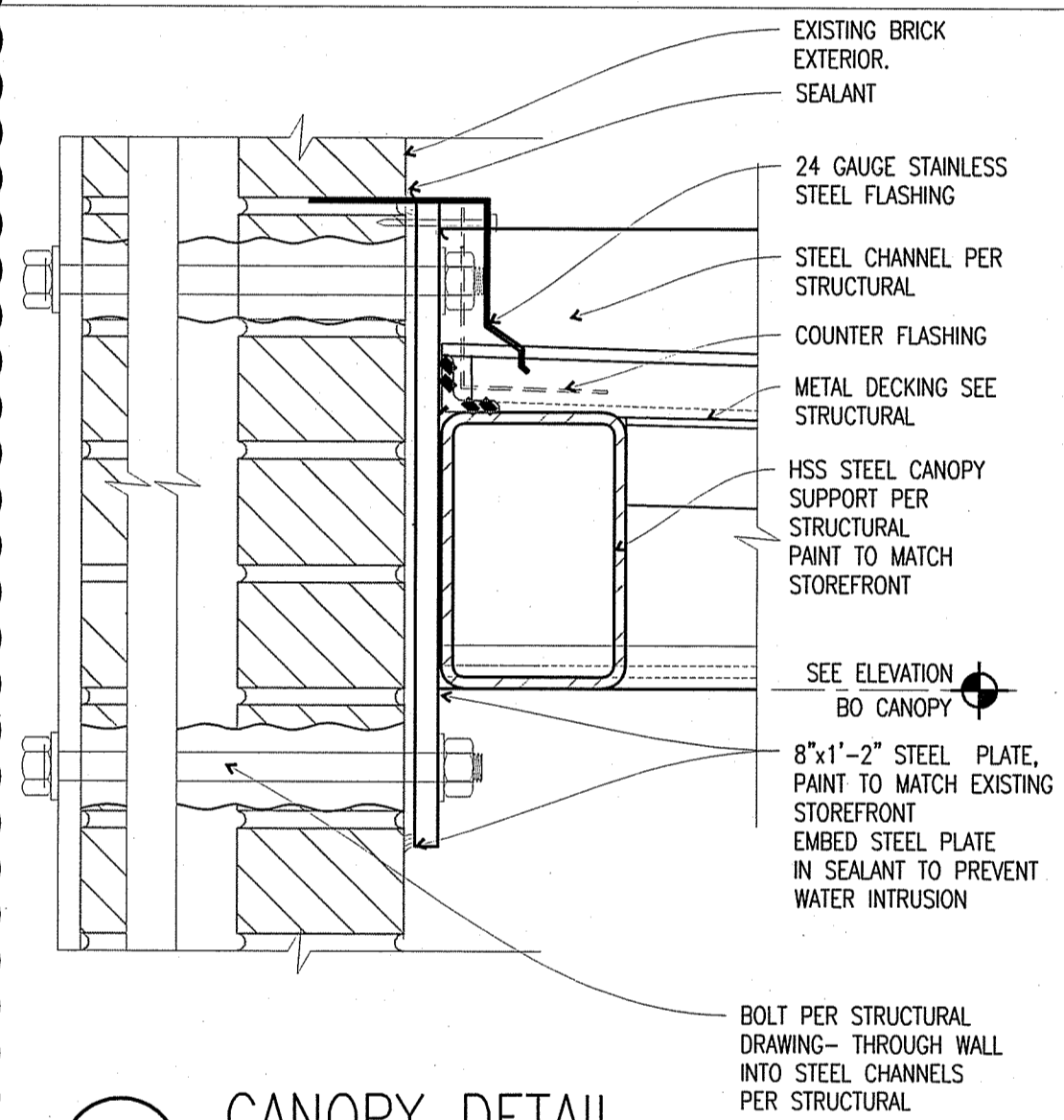

**C7** CANOPY DETAIL  
3'-1'-0"

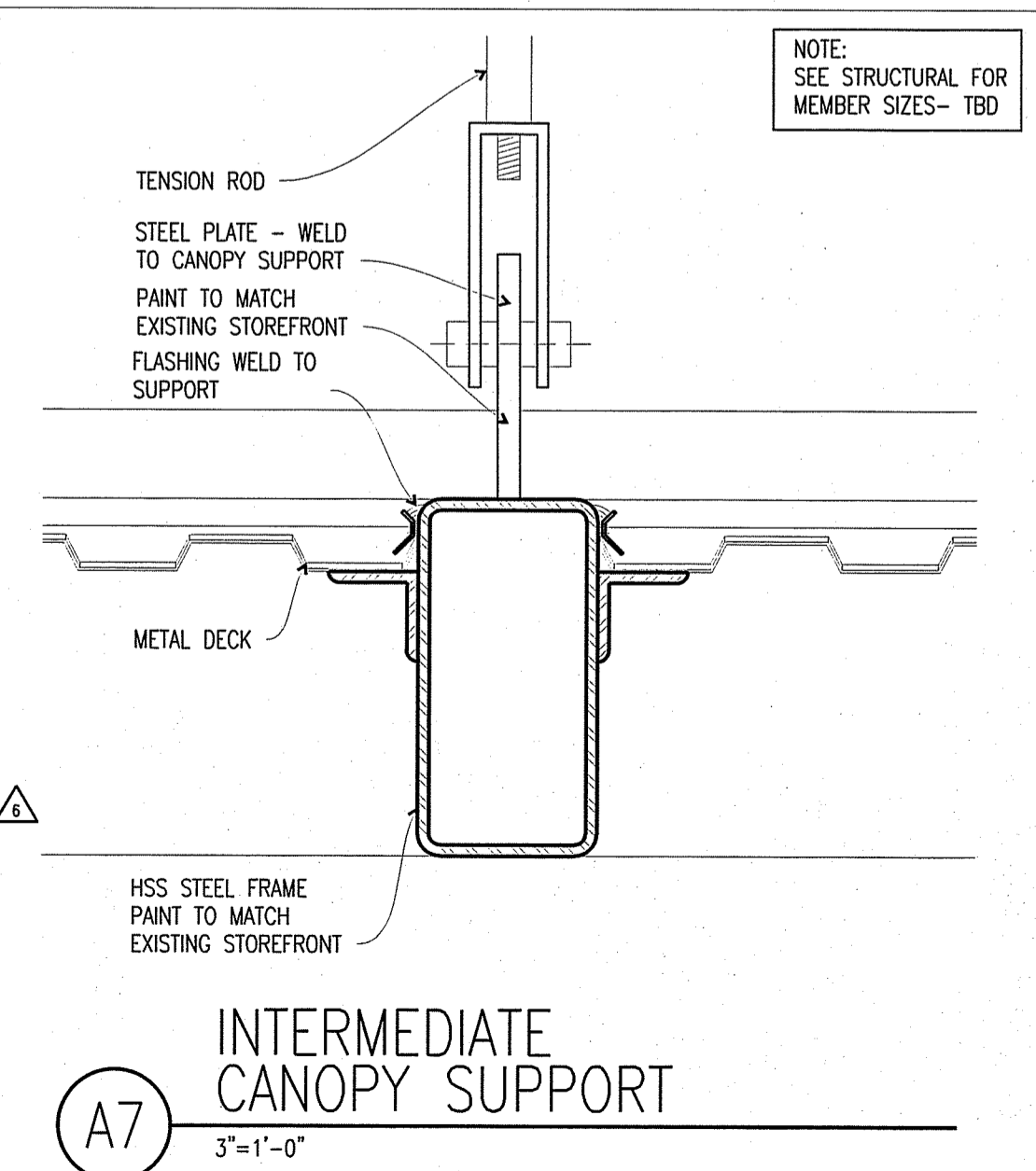

**A7** INTERMEDIATE CANOPY SUPPORT  
3'-1'-0"

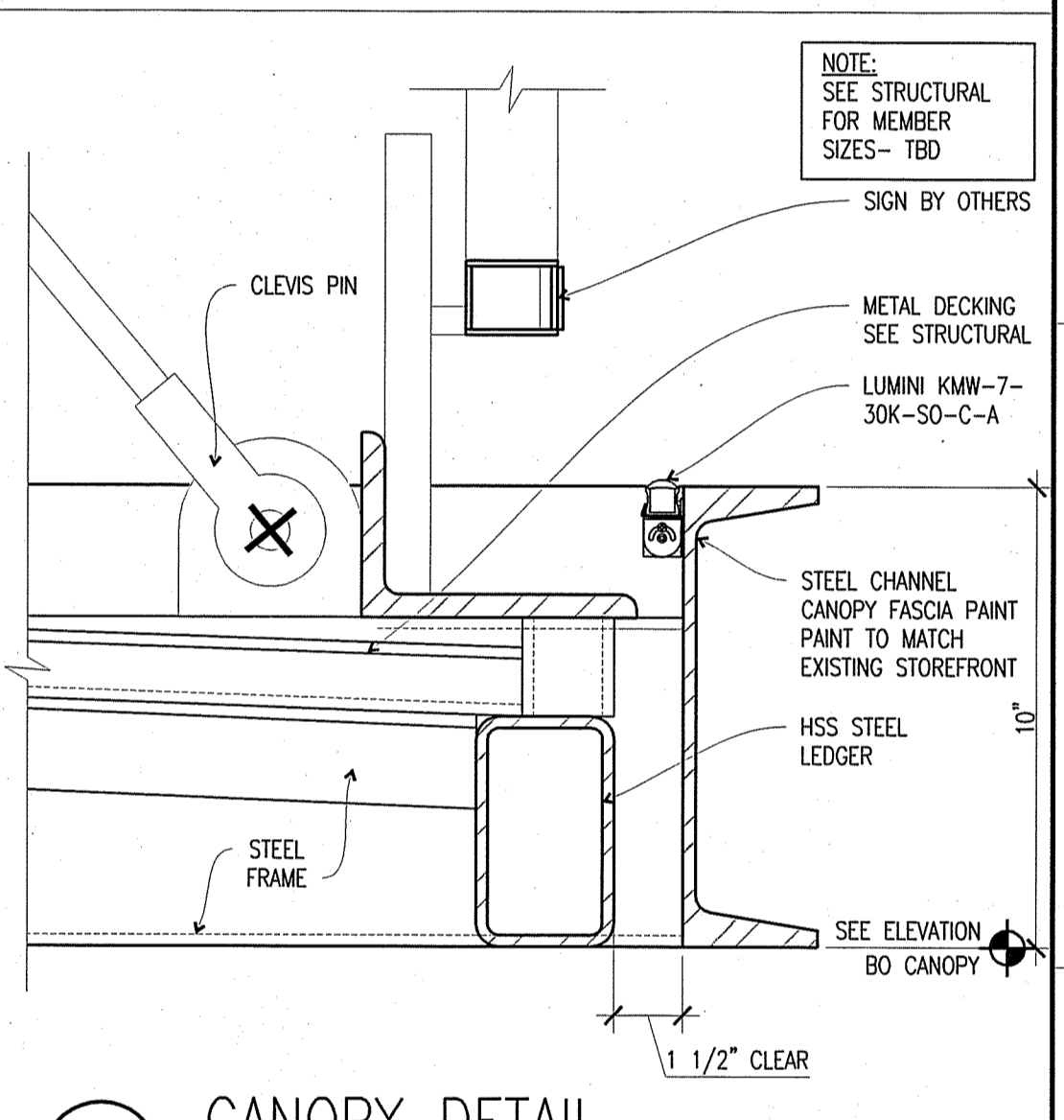

**C9** CANOPY DETAIL  
3'-1'-0"

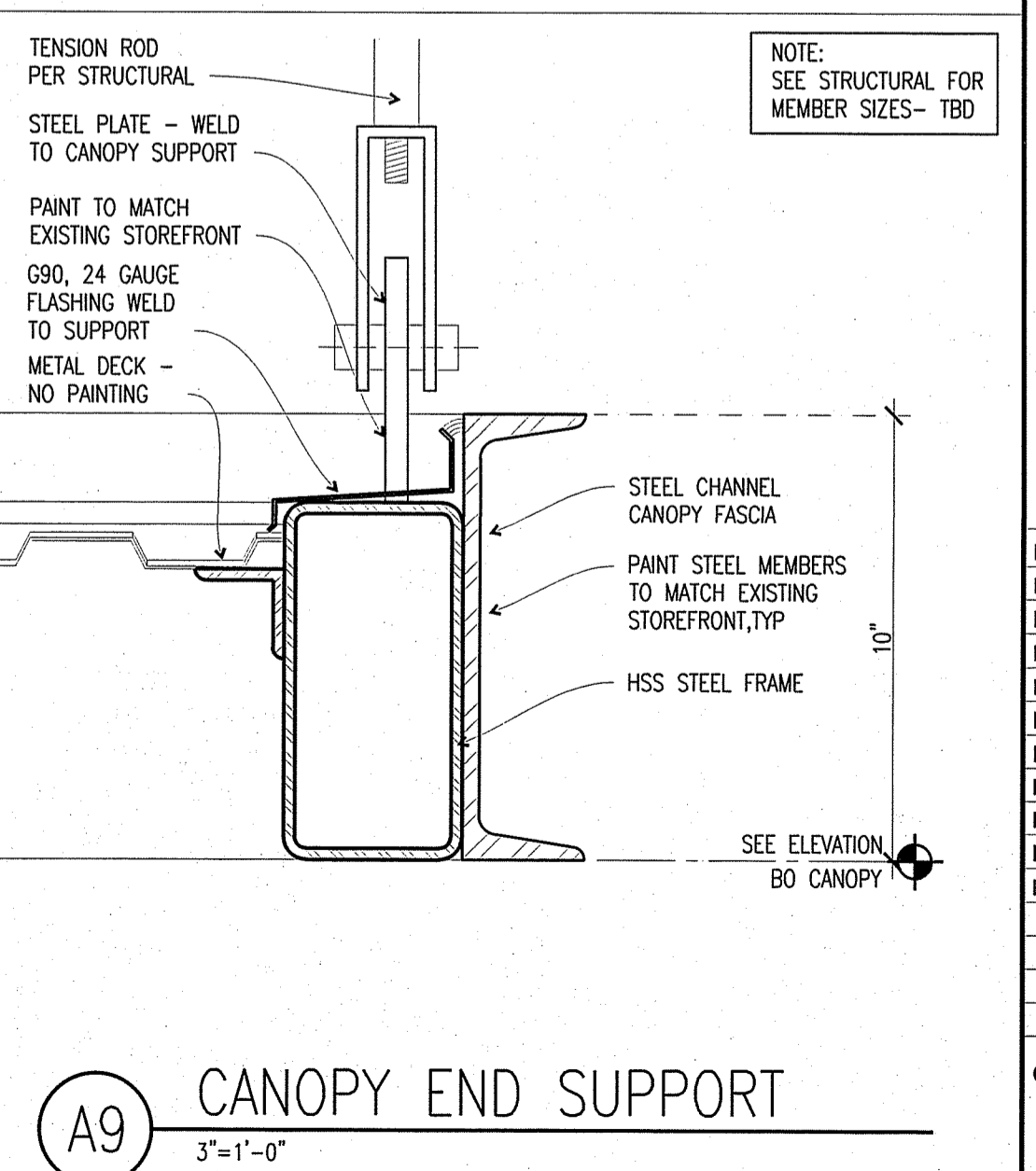

**A9** CANOPY END SUPPORT  
3'-1'-0"

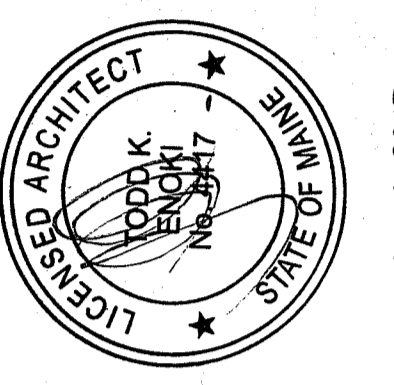

**CALLISONRTKL**  
A DESIGN CONSULTANCY OF ARCADIS  
CALLISONRTKL, INC.  
www.callisonrtkl.com

**west elm**  
Downtown Portland  
164 Middle Street  
Portland, ME 04101  
PROJECT #006-160335.00

ISSUED / REVISED	DATE
PRELIMINARY SET	09/08/16
LL COORDINATION SET	11/08/16
LL/PERMIT SET	11/21/16
HP REVIEW SET	01/11/17
BID SET	01/26/17
PERMIT CORRECTIONS	03/22/17
PERMIT CORRECTIONS-2	04/06/17
PERMIT ADDENDUM	05/05/17
HP REVIEW	05/24/17
PERMIT ADDENDUM 2	06/15/17

CANOPY DETAILS

**A-501**

OWNER:  
**WILLIAMS-SONOMA, INC.**  
3250 Van Ness Avenue  
San Francisco, CA 94109  
T 415 616 8602  
F 415 439 8164  
www.williams-sonoma.com

JUN 12 2017