

F

E

D

C

B

A

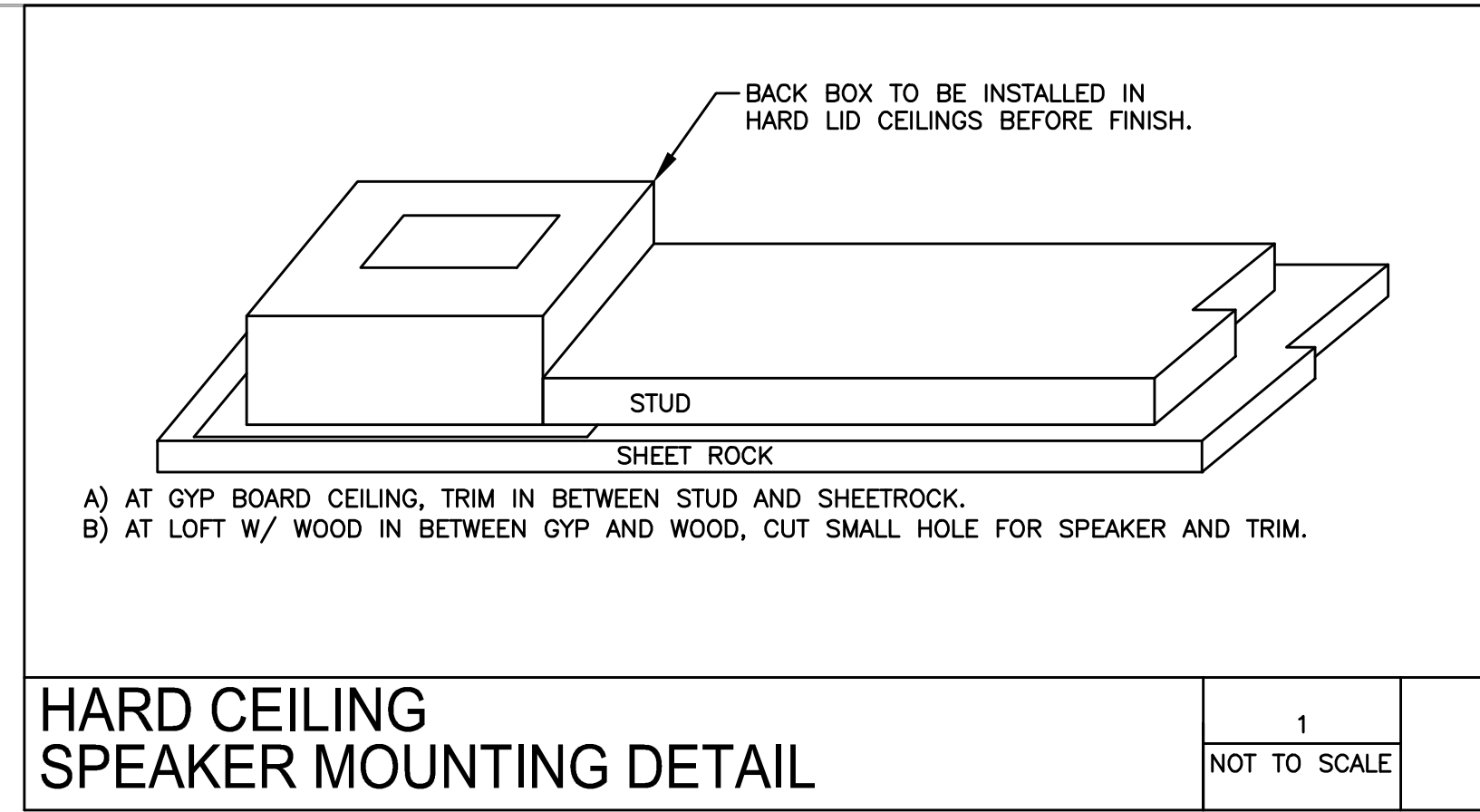

**HARD CEILING SPEAKER MOUNTING DETAIL**

	1	
NOT TO SCALE		

- | SOUND SYSTEM DETAILS |  |
|----------------------|--|
| 1.                   | SEE DETAIL #2, SHEET E-205. SEE DETAILS #1, 2, AND 4 SHEET E-206.          |
| 2.                   | VERIFY THE SPEAKER WIRING WITH SPEAKER VENDOR (SONOS) BEFORE INSTALLATION. |

**SOUND SYSTEM NOTES:**

**GENERAL SHEET NOTES:**

1. USE 16/2 OFHC NON-PLENUM BLACK JACKET CABLE (#1307 A OR 5200UP) FOR ALL 70V LINE SPEAKER RUNS AS INDICATED ON PLANS.
2. USE 14/4 OFHC NON-PLENUM BLACK JACKET CABLE (#1310 A OR 5102UP) FOR ALL SUB WOOFER RUNS AS INDICATED ON PLANS.
3. USE CAT5 CABLE FOR VOLUME CONTROL AND MUSIC ON HOLD.
4. ALL SPEAKER CABLING HOME RUNS SHALL BE RUN TO AUDIO EQUIPMENT RACK BACK PAN LOCATION. CABLE RUNS SHALL BE PARALLEL WITH BUILDING GRID LINES, WITH RIGHT ANGLES, AND DROPS PARALLEL TO VERTICAL. CABLING SHALL BE RUN NEATLY ATTACHED TO STRUCTURE, WITH MINIMAL CABLE SAG.
5. AUDIO EQUIPMENT TO BE INSTALLED IN WALL MOUNTED EQUIPMENT RACK AT LOCATION INDICATED ON THE PLANS.
6. ELECTRICAL CONTRACTOR SHALL INSTALL ALL CABLING INDICATED ON THE PLANS.
7. SOUND SYSTEM VENDOR SHALL FURNISH SPEAKER WIRING (EXCEPT CAT5), BACK CANS (AS REQUIRED), SPEAKERS, SPEAKER YOKES (AS REQUIRED), AND INSULATED SPADE LUG. SOUND SYSTEM VENDOR SHALL BE RESPONSIBLE FOR INSTALLATION OF AUDIO EQUIPMENT IN EQUIPMENT RACK, AND CONNECTION OF ALL HOME RUNS TO AUDIO EQUIPMENT, ANGLE SETTING OF ADJUSTABLE SPEAKERS, TESTING, ALIGNMENT AND TUNING OF AUDIO SYSTEM.
8. GENERAL CONTRACTORS RESPONSIBLE FOR SECURING ALL EQUIPMENT ON SITE.
9. ELECTRICAL CONTRACTOR SHALL INSTALL INSULATED SPADE LUGS AT EACH SPEAKER TERMINATION IN ACCORDANCE WITH THE SOUND SYSTEM VENDOR REQUIREMENTS.

**ELECTRICAL CONTRACTOR RESPONSIBILITIES:**

1. LABEL WIRES ACCORDING TO PLANS AND THE SPEAKER LAYOUT DIAGRAM. PLEASE BE AWARE- IT IS EXTREMELY IMPORTANT THAT ALL WIRES ARE LABELLED DESIGNATION WILL HAVE TO BE TRACED AND CORRECTED BY SOUND SYSTEM VENDOR, AND ADDITIONAL LABOR WILL BE BACK CHARGED TO THE ELECTRICAL CONTRACTOR AT A RATE OF \$75.00 PER HOUR.
2. ELECTRICAL CONTRACTOR TO INSTALL ALL SPEAKERS PER LAYOUT. RUN 70V WIRING AND HOME RUNS AS PER THE WIRING PLAN. CONNECT WIRES TO SPEAKERS AS PER WIRING PLAN/DRAWING/INSTRUCTION AND INSTALL SPEAKERS IN ALL HARD-CEILING AREAS.
3. ANY SPEAKERS NOT WORKING OR INCORRECTLY WIRED WILL HAVE TO BE REPAIRED BY THE ELECTRICAL CONTRACTOR. IF ELECTRICAL CONTRACTOR CANNOT REPAIR DUE TO TIME CONSTRAINTS, SOUND SYSTEM VENDOR WILL REPAIR AND BACK CHARGE THE ELECTRICAL CONTRACTOR AT A RATE OF \$75.00 PER HOUR.

**ELECTRICAL CONTRACTOR RESPONSIBILITIES CONTINUED:**

5. ELECTRICAL CONTRACTOR SHALL PROVIDE CATEGORY 5 CABLING FOR VOLUME CONTROLS
6. ELECTRICAL CONTRACTOR SHALL INSTALL ALL SPEAKER WIRING IN ACCORDANCE WITH THE PLANS.
7. ELECTRICAL CONTRACTOR SHALL INSTALL INSULATED SPADE LUGS AT EACH SPEAKER AND PROVIDE TERMINATION IN ACCORDANCE WITH THE SOUND SYSTEM VENDOR REQUIREMENTS. PROVIDE FINAL TERMINATIONS TO SPEAKER.
8. ELECTRICAL CONTRACTOR SHALL PROVIDE RECEPTACLE, JUNCTION BOX, AND VOICE OUTLET ROUGH-IN WITHIN THE EQUIPMENT RACK BACKPAN.
9. ELECTRICAL CONTRACTOR SHALL CLEAN SOUND SYSTEM EQUIPMENT CABINET FROM DUST AND DEBRIS PRIOR TO SOUND SYSTEM TECHNICIAN ARRIVING ON SITE.

**GENERAL CONTRACTOR RESPONSIBILITIES:**

1. INSTALLATION OF AUDIO EQUIPMENT RACK BACK PAN TO WALL. BACK PROVIDED BY SOUND SYSTEM VENDOR.
2. SECURING ALL EQUIPMENT AND SUPPLIES. ALL MISSING/STOLEN EQUIPMENT WILL BE BACK CHARGED TO THE GENERAL CONTRACTOR.
3. PROVIDING SCHEDULE DELIVERY DATE TO SOUND SYSTEM VENDOR.
4. ENSURING THAT VOLUME CONTROL WIRE HAS BEEN RUN TO CASH WRAP. SPEAKERS ARE INSTALLED. AUDIO EQUIPMENT RACK BACK PAN IS INSTALLED. POWER REQUIREMENTS ARE MET. ALL THIS MUST BE COMPLETED BEFORE SOUND SYSTEM VENDOR TECHNICIAN ARRIVES TO INSTALL AUDIO EQUIPMENT. BE AWARE THAT IF THE TECHNICIAN ARRIVES PER SCHEDULE AND CANNOT COMPLETE THE INSTALLATION THE ELECTRICIAN/GENERAL CONTRACTOR WILL BE BACK CHARGED AT A RATE OF \$75.00 PER HOUR. ADDITIONAL TRAVEL CHARGES WILL ALSO BE BACK CHARGED AT COST.

**SOUND SYSTEM VENDOR RESPONSIBILITIES:**

1. PROVIDING SPEAKER LAYOUT DESIGN AND WIRING SCHEDULE.
2. PROVIDE INSTALLATION INSTRUCTIONS.
3. MAINTAIN COMMUNICATION WITH JOB SITE TO ENSURE TIMELY DELIVERY OF PRODUCTS SUPPLIED.
4. MAINTAIN TECHNICAL SUPPORT FOR INSTALLATION QUESTIONS AND ISSUES.
5. INSTALLATION OF AUDIO EQUIPMENT AND TERMINATION OF WIRES TO EQUIPMENT.
6. ALIGNMENT OF SYSTEM THROUGHOUT STORE. LOCATION WITH ARCHITECTURAL. ACCORDING TO THE WIRING PLAN. ANY WIRES MISLABELED OR MISSING AND "MUSIC ON HOLD", INCLUDING TERMINATIONS.

OWNER:  
**WILLIAMS-SONOMA, INC.**  
 3250 Van Ness Avenue  
 San Francisco, CA 94109  
 T 415 616 8602  
 F 415 439 8164  
 www.williams-sonoma.com



EEA Consulting Engineers  
 6615 Yaught Ranch Road, Suite 200  
 Austin, Texas 78730-2314 USA  
 512.744.4400 main 512.744.4444 fax  
 www.eeac.com

State of Registration: MAINE  
 Firm Registration No. N/A  
 EEA Project No. 20166538

DRAWN BY: BMW  
 CHECKED BY: SMR

**west elm**  
 Downtown Portland  
 164 Middle Street  
 Portland, ME 04101  
 PROJECT #006-160335-00

ISSUED / REVISED	DATE
PRELIMINARY SET	09/08/16
LL COORDINATION SET	11/08/16
LL/PERMIT SET	11/21/16

**SOUND SYSTEM**  
**E-005**