



Submittal

Prepared For:
All Bidders

Date: November 18, 2016

Customer P.O. Number:
Customer Project Number:

Sold To:

Job Number:
Job Name:
HVAC Services - Rob - Retail B

Trane U.S. Inc. dba Trane is pleased to provide the enclosed submittal for your review and approval.

Product Summary

Qty	Product
2	7.5 Ton R410A PKGD Unitary Gas/Electric Rooftop
1	8.5 Ton R410A PKGD Unitary Gas/Electric Rooftop
1	10 Ton R410A PKGD Unitary Gas/Electric Rooftop

The attached information describes the equipment we propose to furnish for this project, and is submitted for your approval.

Daniel Broderick
Trane
860 Spring Street, Unit 1
Westbrook, ME 04092
Phone: (207) 828-1777
Cell:
Fax: (207) 828-1511

Table Of Contents

Product Summary	1
3-10 Ton R410A PKGD Unitary Gas/Electric Rooftop (Items A1 - A4)	3
Tag Data	3
Product Data	3
Mechanical Specifications	4
Unit Dimensions	7
Weight, Clearance & Rigging Diagram.....	14
Accessory	19
Field Wiring	26
Field Installed Options - Part/Order Number Summary	27
3-10 Ton R410A PKGD Unitary Gas/Electric Rooftop.....	27

Tag Data - 3-10 Ton R410A PKGD Unitary Gas/Electric Rooftop (Qty: 4)

Item	Tag(s)	Qty	Description	Model Number
A1	No Tag	1	7.5 Ton R410A PKGD Gas/Electric	YHC092F3RLA--C001A20001A0000000000
A2	No Tag	1	7.5 Ton R410A PKGD Gas/Electric	YHC092F3RLA--C001A2A001A0000000000
A3	No Tag	1	8.5 Ton R410A PKGD Gas/Electric	YHC102F3RLA--C001A20001A0000000000
A4	No Tag	1	10 Ton R410A PKGD Gas/Electric	YHC120F3RLA--C001A20001A0000000000

Product Data - 3-10 Ton R410A PKGD Unitary Gas/Electric Rooftop**All Units**

DX cooling, gas heat
 High efficiency
 Convertible configuration
 Major design sequence
 208-230/60/3
 Microprocessor controls 3ph
 Low gas heat 3ph
 Economizer Dry Bulb 0-100%
 Standard condenser coil w/hail guard
 Through the base electrical 3ph
 Circuit breaker
 Froststat 3ph
 Roof curb (Fld)
 Power exhaust (Fld)
 Return air smoke detector 3ph

Item: A1 Qty: 1

7.5 Ton Dual compressor

Item: A2 Qty: 1

7.5 Ton Dual compressor
 Unpowered convenience outlet (3ph units)

Item: A3 Qty: 1

8.5 Ton

Item: A4 Qty: 1

10 Ton

Mechanical Specifications - 3-10 Ton R410A PKGD Unitary Gas/Electric Rooftop**Item: A1 - A4 Qty: 4****General**

The units shall be convertible airflow. The operating range shall be between 115°F and 0°F in cooling as standard from the factory for units with microprocessor controls. Operating range for units with electromechanical controls shall be between 115°F and 40°F. Cooling performance shall be rated in accordance with ARI testing procedures. All units shall be factory assembled, internally wired, fully charged with R-410A, and 100 percent run tested to check cooling operation, fan and blower rotation, and control sequence before leaving the factory. Wiring internal to the unit shall be colored and numbered for simplified identification. Units shall be cULus listed and labeled, classified in accordance for Central Cooling Air Conditioners.

Casing

Unit casing shall be constructed of zinc coated, heavy gauge, galvanized steel. Exterior surfaces shall be cleaned, phosphatized, and finished with a weather-resistant baked enamel finish. Unit's surface shall be tested 672 hours in a salt spray test in compliance with ASTM B117. Cabinet construction shall allow for all maintenance on one side of the unit. Service panels shall have lifting handles and be removed and reinstalled by removing two fasteners while providing a water and air tight seal. All exposed vertical panels and top covers in the indoor air section shall be insulated with a cleanable foil-faced, fire-retardant permanent, odorless glass fiber material. The base of the unit shall be insulated with 1/8 inch, foil-faced, closed-cell insulation. All insulation edges shall be either captured or sealed. The unit's base pan shall have no penetrations within the perimeter of the curb other than the raised 1 1/8 inch high downflow supply/return openings to provide an added water integrity precaution, if the condensate drain backs up. The base of the unit shall have provisions for forklift and crane lifting, with forklift capabilities on three sides of the unit.

Unit Top

The top cover shall be one piece construction or, where seams exist, it shall be double-hemmed and gasket-sealed. The ribbed top adds extra strength and enhances water removal from unit top.

Filters

Throwaway filters shall be standard on all units. Optional 2-inch MERV 8 and MERV 13 filters shall also be available.

Compressors

All units shall have direct-drive, hermetic, scroll type compressors with centrifugal type oil pumps. Motor shall be suction gas-cooled and shall have a voltage utilization range of plus or minus 10 percent of unit nameplate voltage. Internal overloads shall be provided with the scroll compressors.

Dual compressors are outstanding for humidity control, light load cooling conditions and system back-up applications. Dual compressors are available on 7½-10 ton models and allow for efficient cooling utilizing 3-stages of compressor operation for all high efficiency models.

Notes:

Crankcase heaters are optional on YSC (036, 048, 060, 072, 090, 102, 120); standard on YHC (036, 048, 060, 072, 092, 102, 120).

Indoor Fan

The following units shall be equipped with a direct drive plenum fan design (T/YSC120F, T/YHC074F, T/YHC092F, T/YHC102F, 120F). Plenum fan design shall include a backward-curved fan wheel along with an external rotor direct drive variable speed indoor motor. All plenum fan designs will have a variable speed adjustment potentiometer located in the control box.

3 to 5 ton units (high efficiency 3-phase with optional motor) are belt driven, FC centrifugal fans with adjustable motor sheaves. 3 to 5 ton units (standard and high efficiency 3-phase) have multispeed, direct drive motors. All 6 to 8½ ton units (standard efficiency) shall have belt drive motors with an adjustable idler-arm assembly for quick-adjustment to fan belts and motor sheaves. All motors shall be thermally protected. All 10 tons, 6 ton (074), 7½ to 8½ (high efficiency) units have variable speed direct drive motors. All indoor fan motors meet the U.S. Energy Policy Act of 1992 (EPACT).

Outdoor Fans

The outdoor fan shall be direct-drive, statically and dynamically balanced, draw-through in the vertical discharge position. The fan motor shall be permanently lubricated and shall have built-in thermal overload protection.

Evaporator and Condenser Coils

Internally finned, 5/16" copper tubes mechanically bonded to a configured aluminum plate fin shall be standard. Evaporator coils are standard for all 3 to 10 ton standard efficiency models. Microchannel condenser coils are standard

for all 3 to 10 ton standard efficiency models and 4,5,6, 7.5, 8.5 ton high efficiency models. The microchannel type condenser coil is not offered on the 4 and 5 ton dehumidification model. Due to flat streamlined tubes with small ports, and metallurgical tube-to-fin bond, microchannel coil has better heat transfer performance. Microchannel condenser coil can reduce system refrigerant charge by up to 50% because of smaller internal volume, which leads to better compressor reliability. Compact all-aluminum microchannel coils also help to reduce the unit weight. These all aluminum coils are recyclable. Galvanic corrosion is also minimized due to all aluminum construction. Strong aluminum brazed structure provides better fin protection. In addition, flat streamlined tubes also make microchannel coils more dust resistant and easier to clean. Coils shall be leak tested at the factory to ensure the pressure integrity. The evaporator coil and condenser coil shall be leak tested to 600 psig. The assembled unit shall be leak tested to 465 psig. The condenser coil shall have a patent pending 1+1+1 hybrid coil designed with slight gaps for ease of cleaning. A plastic, dual-sloped, removable and reversible condensate drain pan with through-the-base condensate drain is standard.

Tool-less Hail Guards

Tool-less, hail protection quality coil guards are available for condenser coil protection.

Controls

Unit shall be completely factory-wired with necessary controls and contactor pressure lugs or terminal block for power wiring. Unit shall provide an external location for mounting a fused disconnect device. A choice of microprocessor or electromechanical controls shall be available. Microprocessor controls provide for all 24V control functions. The resident control algorithms shall make all heating, cooling, and/or ventilating decisions in response to electronic signals from sensors measuring indoor and outdoor temperatures. The control algorithm maintains accurate temperature control, minimizes drift from set point, and provides better building comfort. A centralized microprocessor shall provide anti-short cycle timing and time delay between compressors to provide a higher level of machine protection. 24-volt electromechanical control circuit shall include control transformer and contactor

High Pressure Control

All units include High Pressure Cutout as standard.

Phase monitor

Phase monitor shall provide 100% protection for motors and compressors against problems caused by phase loss, phase imbalance, and phase reversal. Phase monitor is equipped with an LED that provides an ON or FAULT indicator. There are no field adjustments. The module will automatically reset from a fault condition.

Refrigerant Circuits

Each refrigerant circuit offer thermal expansion valve as standard. Service pressure ports, and refrigerant line filter driers are factory-installed as standard. An area shall be provided for replacement suction line driers.

Gas Heating Section

The heating section shall have a progressive tubular heat exchanger design using stainless steel burners and corrosion resistant steel throughout. An induced draft combustion blower shall be used to pull the combustion products through the firing tubes. The heater shall use a direct spark ignition (DSI) system. On initial call for heat, the combustion blower shall purge the heat exchanger for 20 seconds before ignition. After three unsuccessful ignition attempts, the entire heating system shall be locked out until manually reset at the thermostat/zone sensor. Units shall be suitable for use with natural gas or propane (field-installed kit) and also comply with the California requirement for low NOx emissions (Gas/Electric Only).

Powered or Unpowered Convenience Outlet

This is a GFCI, 120v/15amp, 2 plug, convenience outlet, either powered or unpowered. When the convenience outlet is powered, a service receptacle disconnect will be available. The convenience outlet is powered from the line side of the disconnect or circuit breaker, and therefore will not be affected by the position of the disconnect or circuit breaker. This option can only be ordered when the Through the Base Electrical with either the Disconnect Switch or Circuit Breaker option is ordered.

Plenum Fan

The following unit shall be equipped with a direct drive plenum fan design (all 10 tons and 7.5-8.5 ton high efficiency units). Plenum fan design shall include a backward-curved fan wheel along with an external rotor direct drive variable speed indoor motor. All plenum fan designs will have a variable speed adjustment potentiometer located in the control box.

Economizer

This accessory shall be available with or without barometric relief. The assembly includes fully modulating 0-100 percent motor and dampers, minimum position setting, preset linkage, wiring harness with plug, spring return actuator

and fixed dry bulb control. The barometric relief shall provide a pressure operated damper that shall be gravity closing and shall prohibit entrance of outside air during the equipment off cycle. Optional solid state or differential enthalpy control shall be available for either factory or field installation. The economizer arrives in the shipping position and shall be moved to the operating position by the installing contractor.

Through the Base Electrical Access

An electrical service entrance shall be provided allowing electrical access for both control and main power connections inside the curb and through the base of the unit. Option will allow for field installation of liquid-tight conduit and an external field-installed disconnect switch.

Through the Base Electrical with Circuit Breaker

This option is a thermal magnetic, molded case, HACR Circuit Breaker with provisions for through the base electrical connections. The circuit breaker will be installed in a water tight enclosure in the unit with access through a swinging door. Wiring will be provided from the switch to the unit high voltage terminal block. The circuit breaker will provide overcurrent protection, be sized per NEC and UL guidelines, and be agency recognized by UL/CSA.

Supply and/or Return Air Smoke Detector

Smoke detector shall be factory installed photoelectric smoke detector mounted in the return air section (with or without the economizer or motorized damper option), AND/OR in the supply air fan compartment. The detector will be wired for continuous power whenever the unit is energized. Upon detection of smoke, the detector will shut down all unit operations. Local codes may dictate the location of detectors. Note: Due to the shipping position of the economizer or motorized damper, the return air smoke detector will not be completely factory installed. The wiring harness for the detector will be routed and tied off in the fan compartment for shipping. The smoke detector and barometric damper hood will also be installed in a shipping position in the fan compartment.

Frostat

This option is to be utilized as a safety device. The Frostat opens when temperatures on the evaporator coil fall below 10°F. The temperature will need to rise to 50°F before closing. This option should be utilized in low airflow or high outside air applications. (Cooling with Electric Heat Only.)

Accessory - Powered Exhaust

The powered exhaust shall provide exhaust of return air, when using an economizer, to maintain better building pressurization.

Accessory - Roof Curb

The roof curb shall be designed to mate with the unit's downflow supply and return and provide support and a water tight installation when installed properly. The roof curb design shall allow field fabricated rectangular supply/return ductwork to be connected directly to the curb. Curb design shall comply with NRCA requirements. Curb shall be shipped knocked down for field assembly and shall include wood nailer strips.

Frostat

This option is to be utilized as a safety device. The Frostat opens when temperatures on the evaporator coil fall below 10°F. The temperature will need to rise to 50°F before closing. This feature should be utilized in low airflow or high outside air applications (cooling only).

Supply, Return, and Plenum Air Smoke Detector

With this option installed, if smoke is detected, all unit operation will be shut down. Reset will be manual at the unit. In order for the supply air smoke detector or return air smoke detector to properly sense smoke in the supply air stream or the return air stream, the air velocity entering the smoke detector unit must be between 500 - 4000 feet per minute. Equipment covered in this manual will develop an airflow velocity that falls within these limits over the entire airflow range specified in the evaporator fan performance table. Supply and/or Return Smoke Detectors may not be used with the Plenum Smoke Detector.

Unit Dimensions - 3-10 Ton R410A PKGD Unitary Gas/Electric Rooftop
Item: A1 - A3 Qty: 3

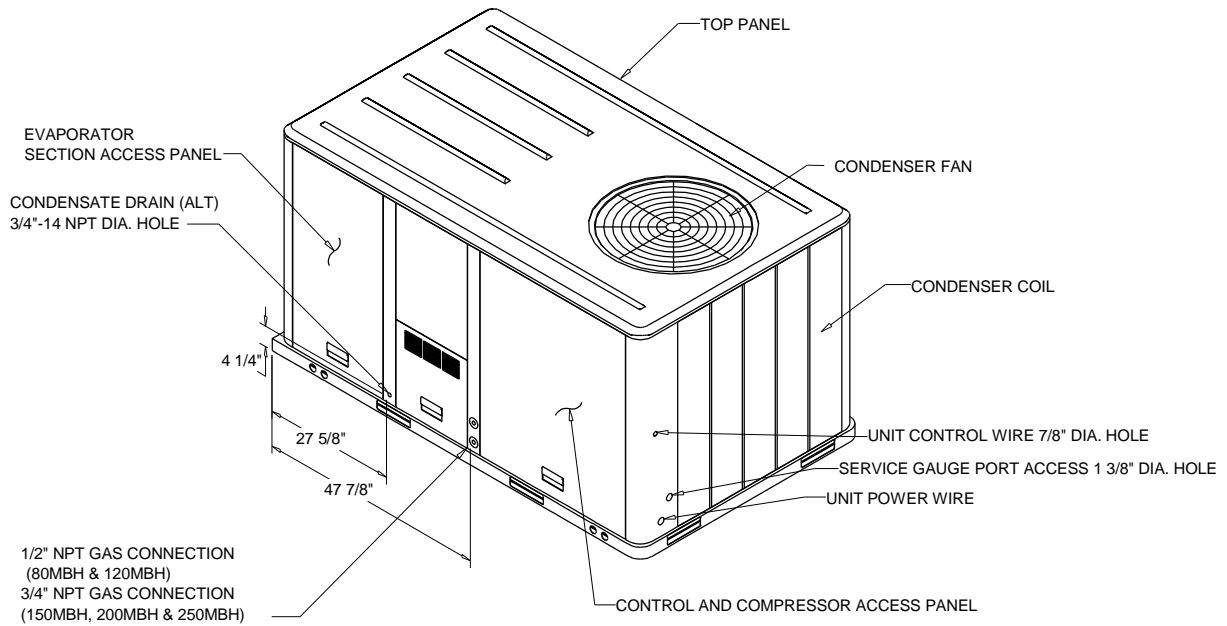

PACKAGED GAS / ELECTRICAL

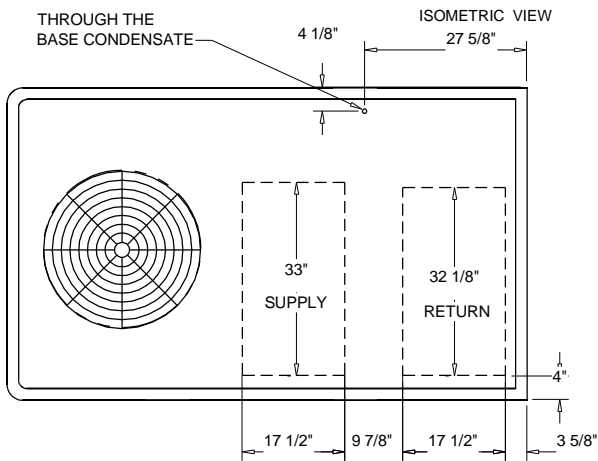

- NOTES:
 1. THRU -THE -BASE ELECTRICAL IS NOT STANDARD ON ALL UNITS.
 2. VERIFY ALL DIMENSIONS WITH INSTALLER DOCUMENTS BEFORE INSTALLATION.

PLAN VIEW UNIT

DIMENSION DRAWING

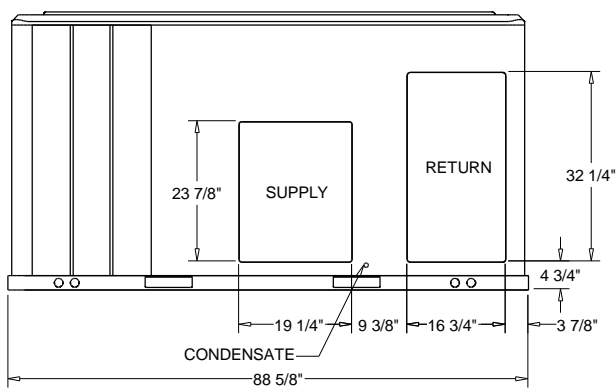

PACKAGED GAS / ELECTRICAL

DIMENSION DRAWING

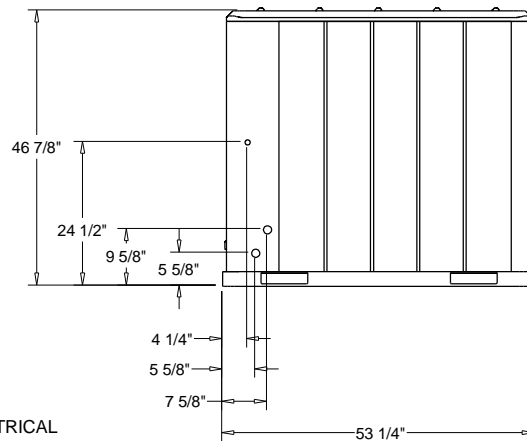

Unit Dimensions - 3-10 Ton R410A PKGD Unitary Gas/Electric Rooftop
Item: A1, A2 Qty: 2

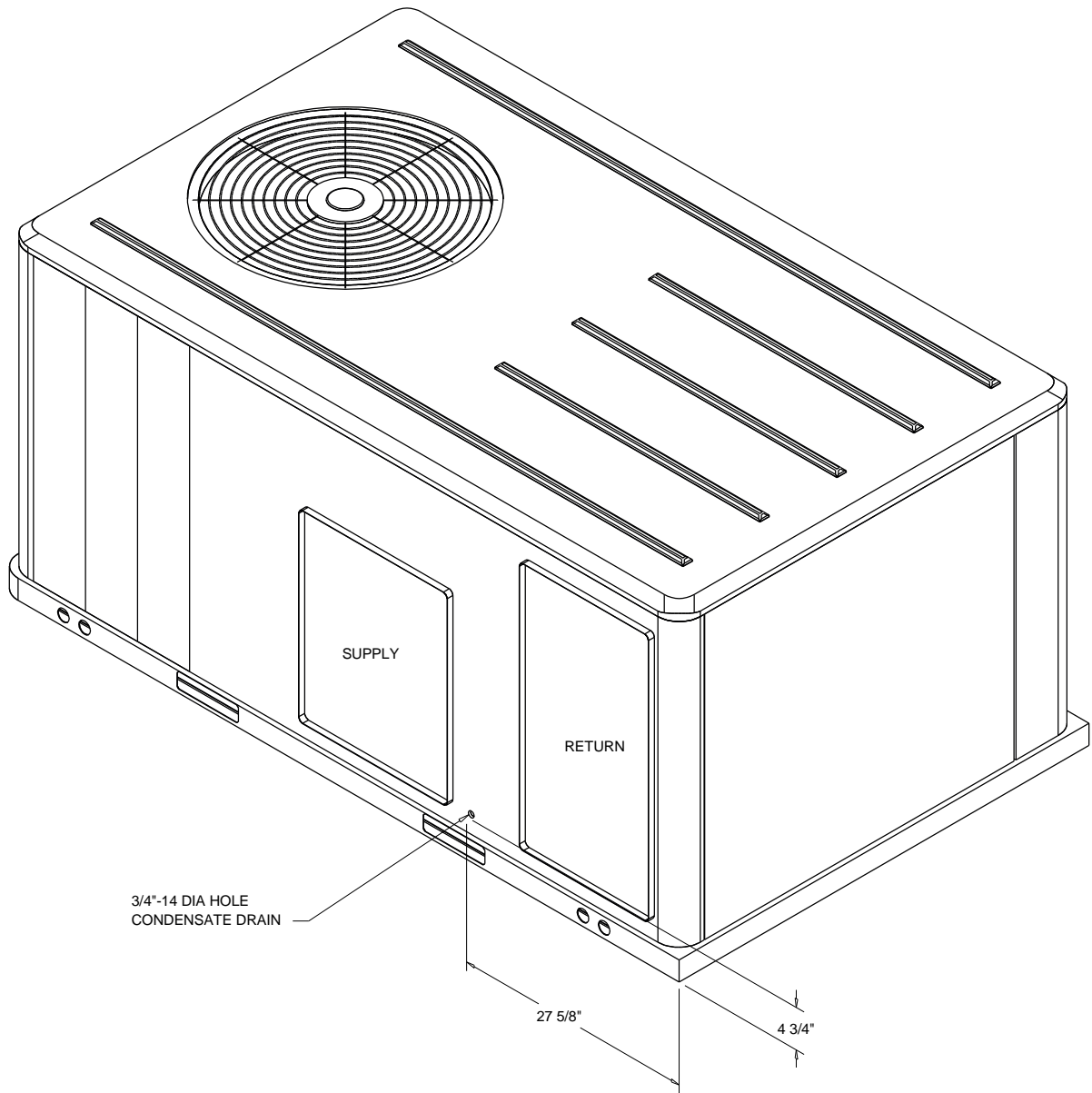

ISOMETRIC-PACKAGED COOLING

Unit Dimensions - 3-10 Ton R410A PKGD Unitary Gas/Electric Rooftop

Item: A1 - A3 Qty: 3

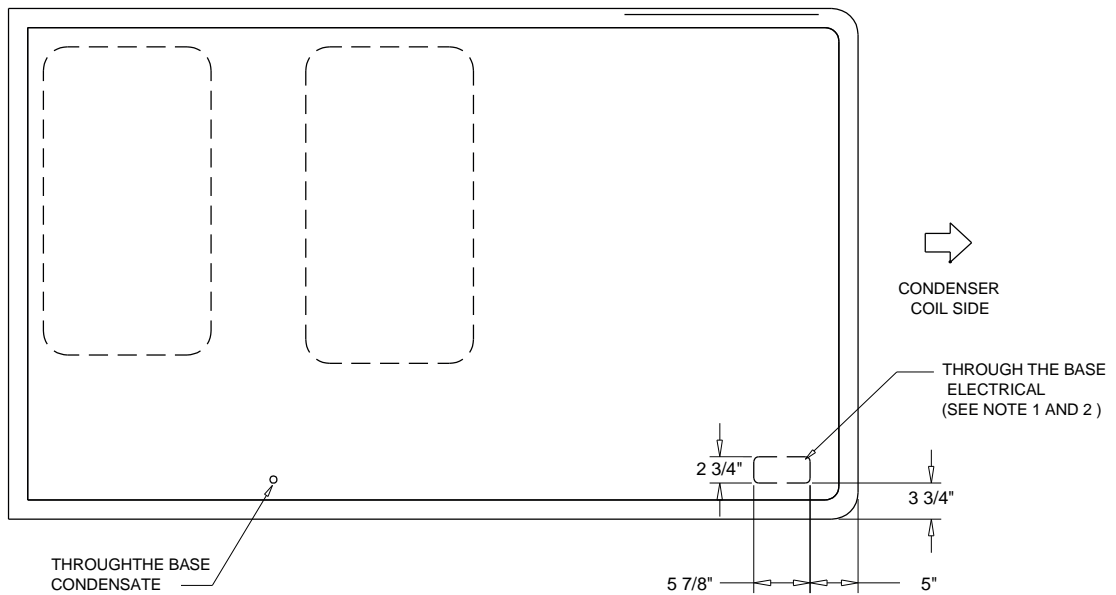
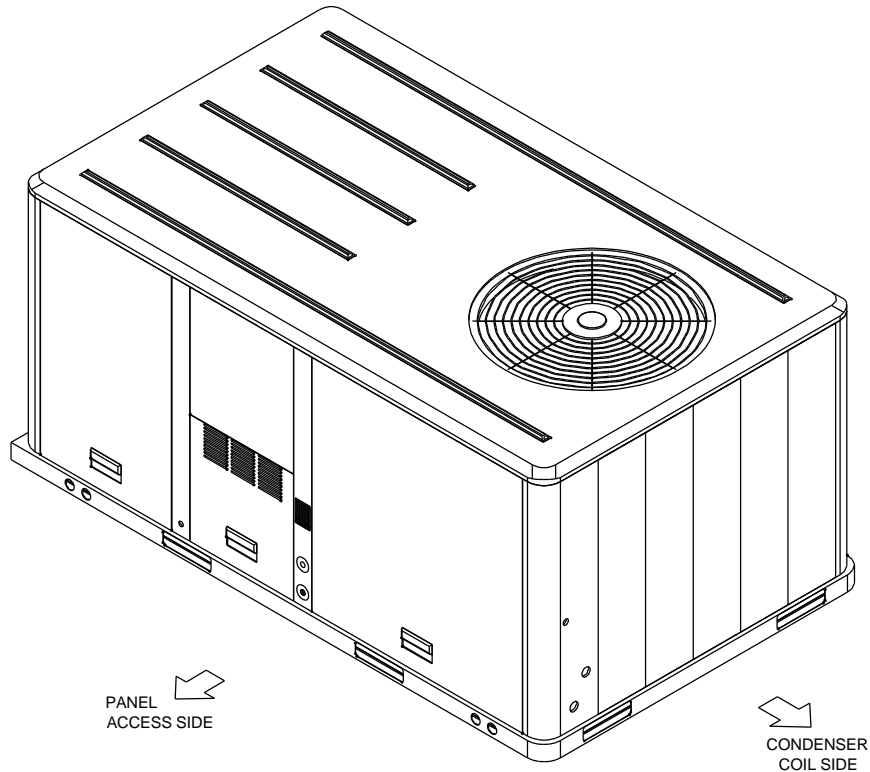

- NOTES:
1. THRU -THE -BASE GAS AND ELECTRICAL IS NOT STANDARD. VERIFY OPTION IN PRODUCT DATA IN THIS DOCUMENT.
 2. VERIFY WEIGHT, CONNECTION, OPTION CONFIGURATION AND ALL DIMENSION WITH INSTALLER DOCUMENTS BEFORE INSTALLATION

THRU THE BASE ELECTRICAL
 PLAN / ISO VIEW DRAWING

Unit Dimensions - 3-10 Ton R410A PKGD Unitary Gas/Electric Rooftop
Item: A1, A2 Qty: 2

ELECTRICAL / GENERAL DATA

GENERAL ⁽²⁾⁽⁴⁾⁽⁶⁾ Model: YHC092F Oversized Motor Unit Operating Voltage: 187-253 MCA: N/A Unit Primary Voltage: 208 MFS: N/A Unit Secondary Voltage: 230 MCB: N/A Unit Hertz: 60 Unit Phase: 3 EER Standard Motor MCA: 42.4 MCA: N/A MFS: 50.0 MFS: N/A MCB: 50.0 MCB: N/A		HEATING PERFORMANCE HEATING - GENERAL DATA Heating Model: Low Heating Input (BTU): 120,000 Heating Output (BTU): 96,000 No. Burners: 3 No. Stages: 1 Gas Inlet Pressure Natural Gas (Min/Max): 4.5/14 LP (Min/Max): 11.0/14.0 Gas Pipe Connection Size: 1/2"	
INDOOR MOTOR Standard Motor Oversized Motor Field Installed Oversized Motor Number: 1 Number: N/A Number: N/A Horsepower: 3.8 Horsepower: N/A Horsepower: N/A Motor Speed (RPM): -- Motor Speed (RPM): N/A Motor Speed (RPM): N/A Phase: 3 Phase: N/A Phase: N/A Full Load Amps: 8.5 - 8.5 Full Load Amps: N/A Full Load Amps: N/A Locked Rotor Amps: -- Locked Rotor Amps: N/A Locked Rotor Amps: N/A			
COMPRESSOR Circuit 1/2 Number: 2 Horsepower: 4.1/2.4 Phase: 3 Rated Load Amps: 15.9/10.0 Locked Rotor Amps: 110.0/71.0		OUTDOOR MOTOR Number: 1 Horsepower: 0.75 Motor Speed (RPM): 1100 Phase: 1 Full Load Amps: 4.0 Locked Rotor Amps: 9.3	
POWER EXHAUST ACCESSORY ⁽³⁾ (Field Installed Power Exhaust) Phase: 1 Horsepower: 0.87 Motor Speed (RPM): 1075 Full Load Amps: 5.7 Locked Rotor Amps: 13.6	FILTERS Type: Throwaway Furnished: Yes Number: 4 Recommended: 20"x25"x2"		REFRIGERANT ⁽²⁾ Type: R-410 Factory Charge Circuit #1: 5.5 lb Circuit #2: 4.2 lb

NOTES:

- 1. Maximum (HACR) Circuit Breaker sizing is for installations in the United States only.
- 2. Refrigerant charge is an approximate value. For a more precise value, see unit nameplate and service instructions.
- 3. Value does not include Power Exhaust Accessory.
- 4. Value includes oversized motor.
- 5. Value does not include Power Exhaust Accessory.
- 6. EER is rated at AHRI conditions and in accordance with DOE test procedures.

Unit Dimensions - 3-10 Ton R410A PKGD Unitary Gas/Electric Rooftop
Item: A3 Qty: 1

ELECTRICAL / GENERAL DATA

GENERAL ⁽²⁾⁽⁴⁾⁽⁶⁾ Model: YHC102F Oversized Motor Unit Operating Voltage: 187-253 MCA: N/A Unit Primary Voltage: 208 MFS: N/A Unit Secondary Voltage: 230 MCB: N/A Unit Hertz: 60 Unit Phase: 3 EER Standard Motor MCA: 42.0 MCA: N/A MFS: 50.0 MFS: N/A MCB: 50.0 MCB: N/A		HEATING PERFORMANCE HEATING - GENERAL DATA Heating Model: Low Heating Input (BTU): 120,000 Heating Output (BTU): 96,000 No. Burners: 3 No. Stages: 1 Gas Inlet Pressure Natural Gas (Min/Max): 4.5/14 LP (Min/Max): 11.0/14.0 Gas Pipe Connection Size: 1/2"					
INDOOR MOTOR Standard Motor Number: 1 Horsepower: 3.8 Motor Speed (RPM): -- Phase: 3 Full Load Amps: 8.5 - 8.5 Locked Rotor Amps: --				Oversized Motor Number: N/A Horsepower: N/A Motor Speed (RPM): N/A Phase: N/A Full Load Amps: N/A Locked Rotor Amps: N/A		Field Installed Oversized Motor Number: N/A Horsepower: N/A Motor Speed (RPM): N/A Phase: N/A Full Load Amps: N/A Locked Rotor Amps: N/A	
COMPRESSOR Circuit 1/2 Number: 2 Horsepower: 4.5/2.4 Phase: 3 Rated Load Amps: 15.6/10.0 Locked Rotor Amps: 110.0/71.0		OUTDOOR MOTOR Number: 1 Horsepower: 0.75 Motor Speed (RPM): 1100 Phase: 1 Full Load Amps: 4.0 Locked Rotor Amps: 9.3					
POWER EXHAUST ACCESSORY ⁽³⁾ (Field Installed Power Exhaust) Phase: 1 Horsepower: 0.87 Motor Speed (RPM): 1075 Full Load Amps: 5.7 Locked Rotor Amps: 13.6		FILTERS Type: Throwaway Furnished: Yes Number: 4 Recommended: 20"x25"x2"		REFRIGERANT ⁽²⁾ Type: R-410 Factory Charge Circuit #1: 6.3 lb Circuit #2: 4.9 lb			

NOTES:

1. Maximum (HACR) Circuit Breaker sizing is for installations in the United States only.
2. Refrigerant charge is an approximate value. For a more precise value, see unit nameplate and service instructions.
3. Value does not include Power Exhaust Accessory.
4. Value includes oversized motor.
5. Value does not include Power Exhaust Accessory.
6. EER is rated at AHRI conditions and in accordance with DOE test procedures.

Unit Dimensions - 3-10 Ton R410A PKGD Unitary Gas/Electric Rooftop
Item: A4 Qty: 1

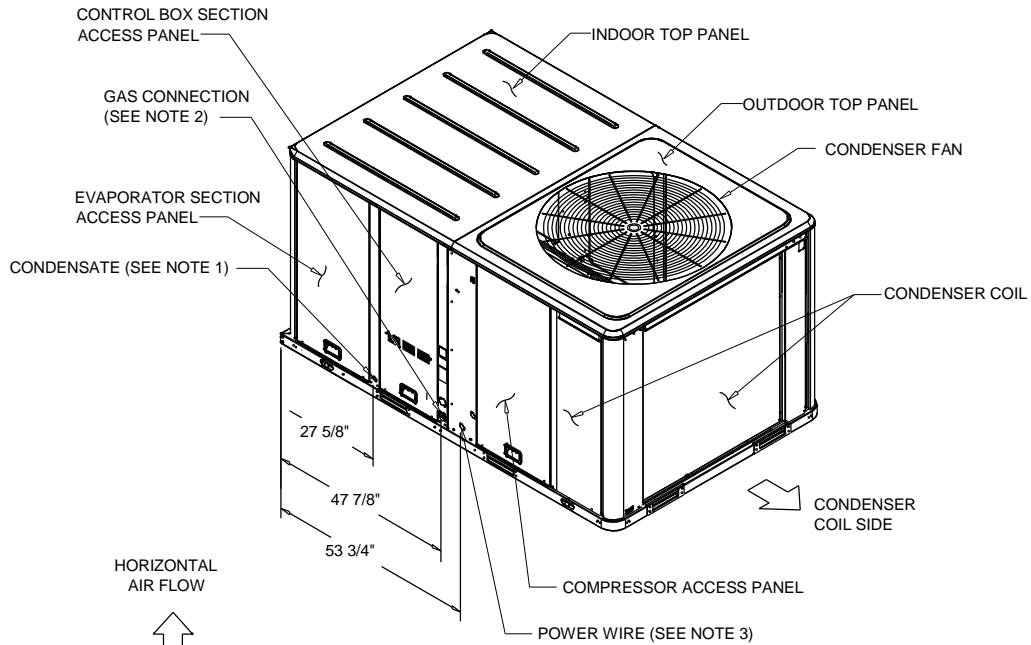

PACKAGED GAS / ELECTRICAL

ISOMETRIC VIEW

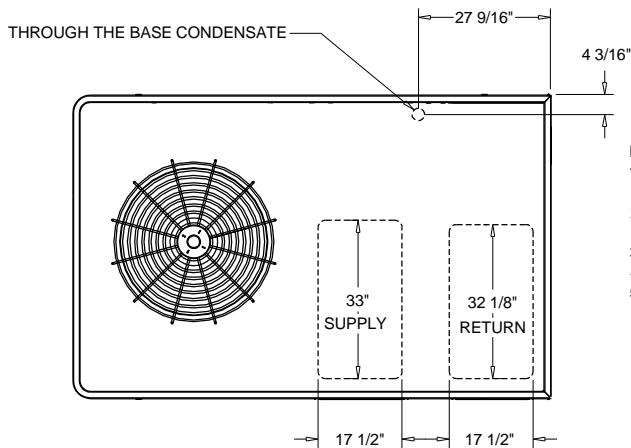

NOTES:

1. ALTERNATE CONDENSATE DRAIN CONNECTION 3/4" - 14 NPT DIA. HOLE
2. 1/2" NPT GAS CONNECTION (80 mbh, 120 mbh) ; 3/4" NPT GAS CONNECTION (150mbh, 200mbh, 250mbh)
3. UNIT POWER WIRE 1 3/8" DIA. HOLE.
4. THRU -THE -BASE ELECTRICAL AND GAS IS NOT STANDARD ON ALL UNITS.
5. VERIFY WEIGHT, CONNECTION, AND ALL DIMENSION WITH INSTALLER DOCUMENTS BEFORE INSTALLATION

PLAN VIEW UNIT

DIMENSION DRAWING

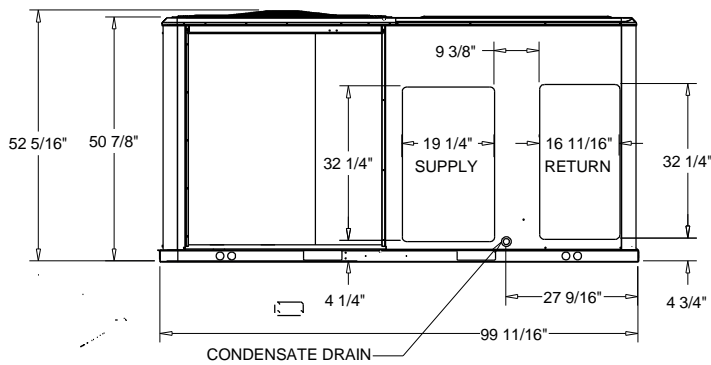

PACKAGED GAS / ELECTRICAL

DIMENSION DRAWING

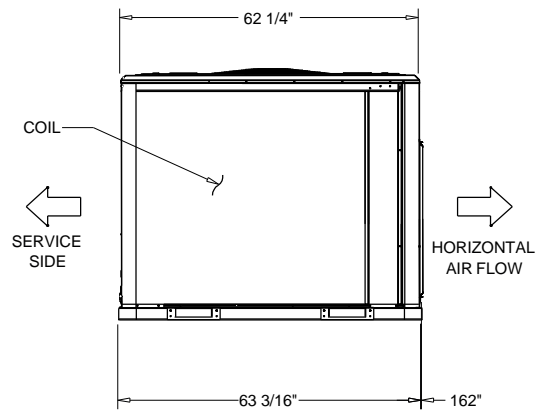

Unit Dimensions - 3-10 Ton R410A PKGD Unitary Gas/Electric Rooftop
Item: A4 Qty: 1

ELECTRICAL / GENERAL DATA

GENERAL ⁽²⁾⁽⁴⁾⁽⁶⁾ Model: YHC120F Oversized Motor Unit Operating Voltage: 187-253 MCA: N/A Unit Primary Voltage: 208 MFS: N/A Unit Secondary Voltage: 230 MCB: N/A Unit Hertz: 60 Unit Phase: 3 EER Standard Motor MCA: 46.1 MCA: N/A MFS: 60.0 MFS: N/A MCB: 60.0 MCB: N/A		HEATING PERFORMANCE HEATING - GENERAL DATA Heating Model: Low Heating Input (BTU): 150,000/105,000 Heating Output (BTU): 120,000/84,000 No. Burners: 3 No. Stages: 2 Gas Inlet Pressure Natural Gas (Min/Max): 4.5/14 LP (Min/Max): 10.0/14.0 Gas Pipe Connection Size: 3/4"	
INDOOR MOTOR Standard Motor Number: 1 Horsepower: 3.8 Motor Speed (RPM): -- Phase: 3 Full Load Amps: 8.5 - 8.5 Locked Rotor Amps: -- Oversized Motor Number: N/A Horsepower: N/A Motor Speed (RPM): N/A Phase: N/A Full Load Amps: N/A Locked Rotor Amps: N/A Field Installed Oversized Motor Number: N/A Horsepower: N/A Motor Speed (RPM): N/A Phase: N/A Full Load Amps: N/A Locked Rotor Amps: N/A			
COMPRESSOR Circuit 1/2 Number: 2 Horsepower: 5.1/3.0 Phase: 3 Rated Load Amps: 19.6/10.4 Locked Rotor Amps: 136.0/73.0		OUTDOOR MOTOR Number: 1 Horsepower: 0.75 Motor Speed (RPM): 1100 Phase: 3 Full Load Amps: 2.7 Locked Rotor Amps: 9.8	
POWER EXHAUST ACCESSORY ⁽³⁾ (Field Installed Power Exhaust) Phase: 1 Horsepower: 0.87 Motor Speed (RPM): 1075 Full Load Amps: 5.7 Locked Rotor Amps: 13.6	FILTERS Type: Throwaway Furnished: Yes Number: 3 / 2 Recommended: 20"x25"x2" 20"x30"x2"		REFRIGERANT ⁽²⁾ Type: R-410 Factory Charge Circuit #1: 7.1 lb Circuit #2: 5.0 lb

NOTES:

1. Maximum (HACR) Circuit Breaker sizing is for installations in the United States only.
2. Refrigerant charge is an approximate value. For a more precise value, see unit nameplate and service instructions.
3. Value does not include Power Exhaust Accessory.
4. Value includes oversized motor.
5. Value does not include Power Exhaust Accessory.
6. EER is rated at AHRI conditions and in accordance with DOE test procedures.

Weight, Clearance & Rigging Diagram - 3-10 Ton R410A PKGD Unitary Gas/Electric Rooftop
 Item: A1, A2 Qty: 2

INSTALLED ACCESSORIES NET WEIGHT DATA

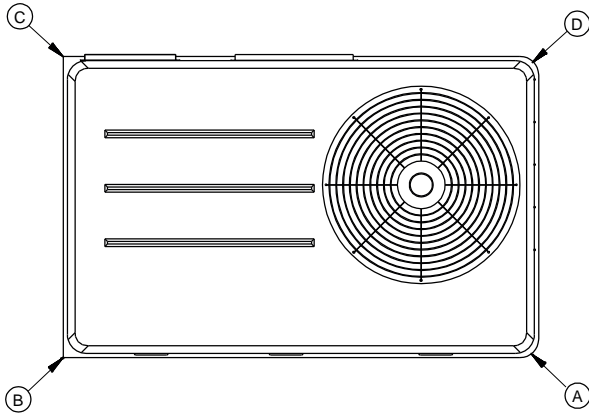

PACKAGED GAS / ELECTRICAL
 CORNER WEIGHT

ACCESSORY		WEIGHTS			
ECONOMIZER		36.0 lb			
MOTORIZED OUTSIDE AIR DAMPER					
MANUAL OUTSIDE AIR DAMPER					
BAROMETRIC RELIEF					
OVERSIZED MOTOR					
BELT DRIVE MOTOR					
POWER EXHAUST		80.0 lb			
THROUGH THE BASE ELECTRICAL/GAS (FIOPS)		13.0 lb			
UNIT MOUNTED CIRCUIT BREAKER (FIOPS)		5.0 lb			
UNIT MOUNTED DISCONNECT (FIOPS)					
POWERED CONVENIENCE OUTLET (FIOPS)					
HINGED DOORS (FIOPS)					
HAIL GUARD		20.0 lb			
SMOKE DETECTOR, SUPPLY / RETURN		7.0 lb			
NOVAR CONTROL					
STAINLESS STEEL HEAT EXCHANGER					
REHEAT					
ROOF CURB		78.0 lb			
BASIC UNIT WEIGHTS		CORNER WEIGHTS		CENTER OF GRAVITY	
SHIPPING	NET	(A)	(C)	(E) LENGHT	(F) WIDTH
1124.0 lb	1026.0 lb	(B) 233.0 lb	(D) 204.0 lb	41"	23"

NOTE:

1. All weights are approximate.
2. Weights for options that are not list refer to Installation guide.
3. The actual weight are listed on the unit nameplate.
4. Refer to unit nameplate and installation guide for weights before scheduling transportation and installation of unit.
5. The weight shown represents the typical unit operating weight for the configuration selected. Estimated at +/- 10 % of the nameplate weight. .
6. Verify weight, connection, and all dimension with installer documents before installation.
7. Corner weights are given for information only.
8. Net/Shipping weight of optional accessories should be added to unit weight when ordering factory or field installed accessories.

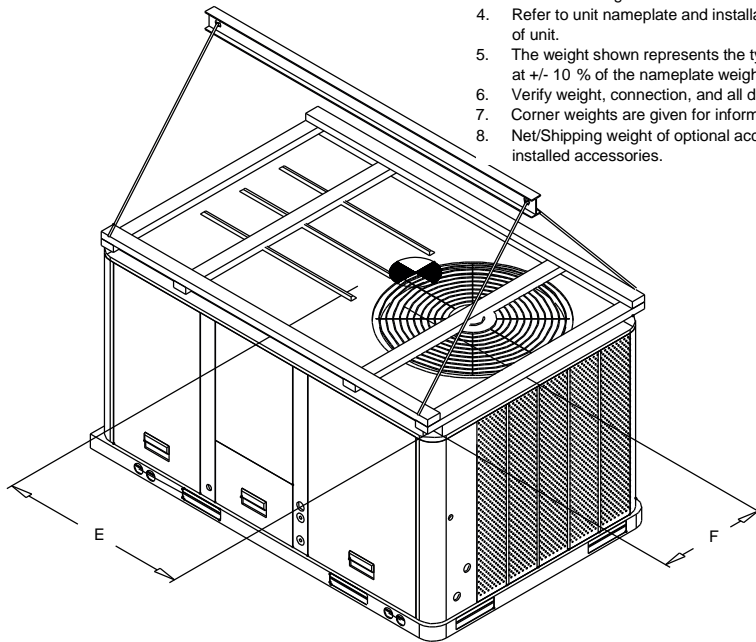

PACKAGED GAS / ELECTRICAL
 RIGGING AND CENTER OF GRAVITY

Weight, Clearance & Rigging Diagram - 3-10 Ton R410A PKGD Unitary Gas/Electric Rooftop
Item: A1 - A3 Qty: 3

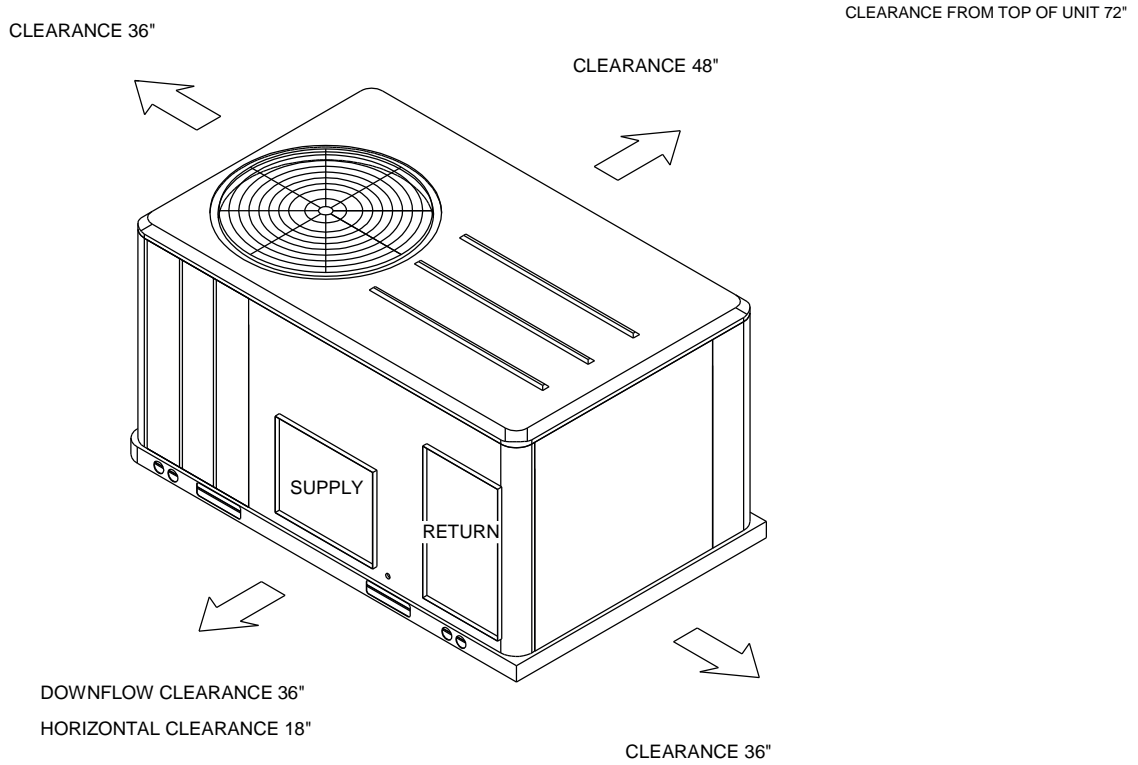

PACKAGED GAS / ELECTRIC

CLEARANCE

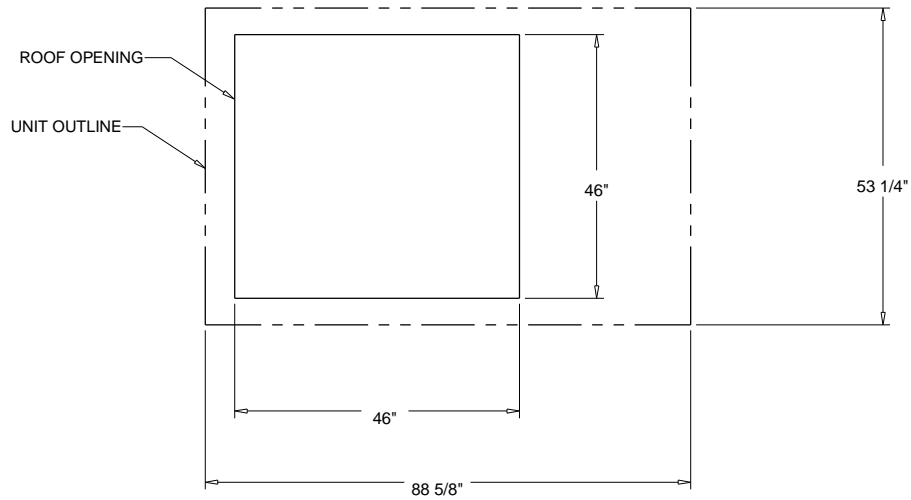

PACKAGED GAS / ELECTRIC

DOWNFLOW TYPICAL ROOF OPENING

Weight, Clearance & Rigging Diagram - 3-10 Ton R410A PKGD Unitary Gas/Electric Rooftop
Item: A3 Qty: 1

INSTALLED ACCESSORIES NET WEIGHT DATA

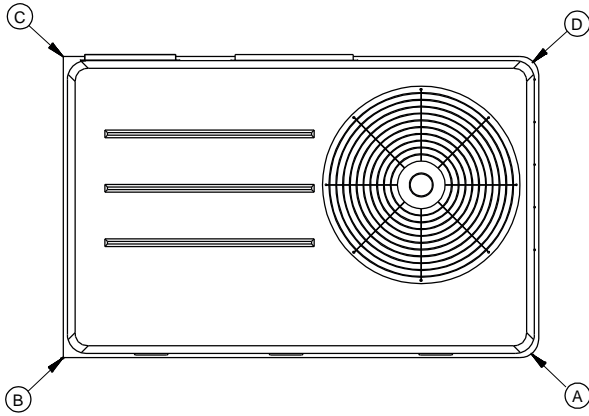

PACKAGED GAS / ELECTRICAL
 CORNER WEIGHT

ACCESSORY		WEIGHTS			
ECONOMIZER		36.0 lb			
MOTORIZED OUTSIDE AIR DAMPER					
MANUAL OUTSIDE AIR DAMPER					
BAROMETRIC RELIEF					
OVERSIZED MOTOR					
BELT DRIVE MOTOR					
POWER EXHAUST		80.0 lb			
THROUGH THE BASE ELECTRICAL/GAS (FIOPS)		13.0 lb			
UNIT MOUNTED CIRCUIT BREAKER (FIOPS)		5.0 lb			
UNIT MOUNTED DISCONNECT (FIOPS)					
POWERED CONVENIENCE OUTLET (FIOPS)					
HINGED DOORS (FIOPS)					
HAIL GUARD		30.0 lb			
SMOKE DETECTOR, SUPPLY / RETURN		7.0 lb			
NOVAR CONTROL					
STAINLESS STEEL HEAT EXCHANGER					
REHEAT					
ROOF CURB		89.0 lb			
BASIC UNIT WEIGHTS		CORNER WEIGHTS		CENTER OF GRAVITY	
SHIPPING	NET	(A)	(C)	(E) LENGHT	(F) WIDTH
1133.0 lb	1035.0 lb	(B) 236.0 lb	(D) 205.0 lb	49"	23"

NOTE:

1. All weights are approximate.
2. Weights for options that are not list refer to Installation guide.
3. The actual weight are listed on the unit nameplate.
4. Refer to unit nameplate and installation guide for weights before scheduling transportation and installation of unit.
5. The weight shown represents the typical unit operating weight for the configuration selected. Estimated at +/- 10 % of the nameplate weight. .
6. Verify weight, connection, and all dimension with installer documents before installation.
7. Corner weights are given for information only.
8. Net/Shipping weight of optional accessories should be added to unit weight when ordering factory or field installed accessories.

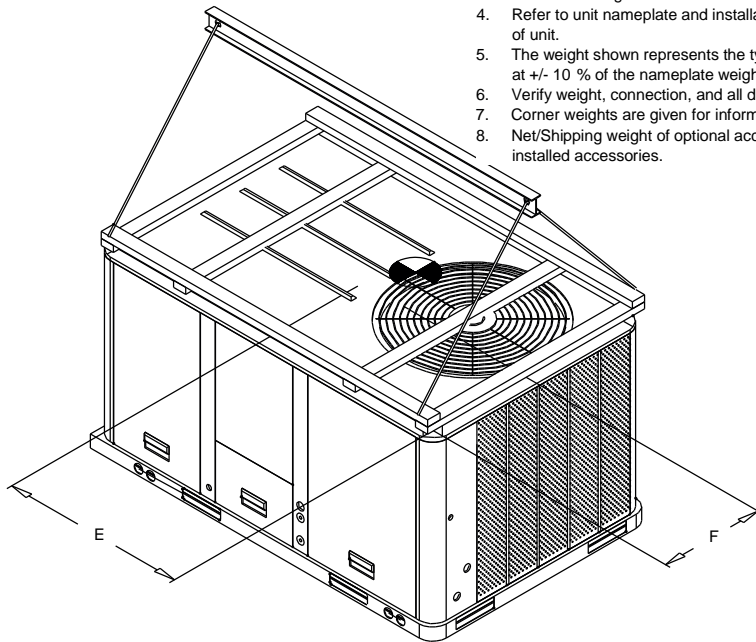

PACKAGED GAS / ELECTRICAL
 RIGGING AND CENTER OF GRAVITY

Weight, Clearance & Rigging Diagram - 3-10 Ton R410A PKGD Unitary Gas/Electric Rooftop
 Item: A4 Qty: 1

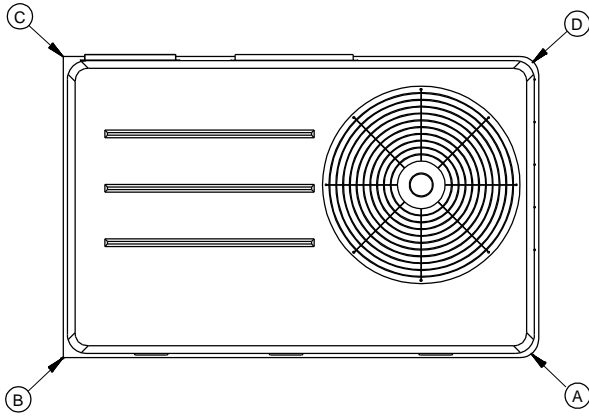

PACKAGED GAS / ELECTRICAL
 CORNER WEIGHT

INSTALLED ACCESSORIES NET WEIGHT DATA

ACCESSORY		WEIGHTS			
ECONOMIZER		36.0 lb			
MOTORIZED OUTSIDE AIR DAMPER					
MANUAL OUTSIDE AIR DAMPER					
BAROMETRIC RELIEF					
OVERSIZED MOTOR					
BELT DRIVE MOTOR					
POWER EXHAUST		80.0 lb			
THROUGH THE BASE ELECTRICAL/GAS (FIOPS)		13.0 lb			
UNIT MOUNTED CIRCUIT BREAKER (FIOPS)		5.0 lb			
UNIT MOUNTED DISCONNECT (FIOPS)					
POWERED CONVENIENCE OUTLET (FIOPS)					
HINGED DOORS (FIOPS)					
HAIL GUARD		30.0 lb			
SMOKE DETECTOR, SUPPLY / RETURN		7.0 lb			
NOVAR CONTROL					
STAINLESS STEEL HEAT EXCHANGER					
REHEAT					
ROOF CURB		89.0 lb			
BASIC UNIT WEIGHTS		CORNER WEIGHTS		CENTER OF GRAVITY	
SHIPPING	NET	(A)	(C)	(E) LENGHT	(F) WIDTH
1453.0 lb	1259.0 lb	(B) 371.0 lb	(D) 242.0 lb	54"	27"

NOTE:

1. All weights are approximate.
2. Weights for options that are not list refer to Installation guide.
3. The actual weight are listed on the unit nameplate.
4. Refer to unit nameplate and installation guide for weights before scheduling transportation and installation of unit.
5. The weight shown represents the typical unit operating weight for the configuration selected. Estimated at +/- 10 % of the nameplate weight. .
6. Verify weight, connection, and all dimension with installer documents before installation.
7. Corner weights are given for information only.
8. Net/Shipping weight of optional accessories should be added to unit weight when ordering factory or field installed accessories.

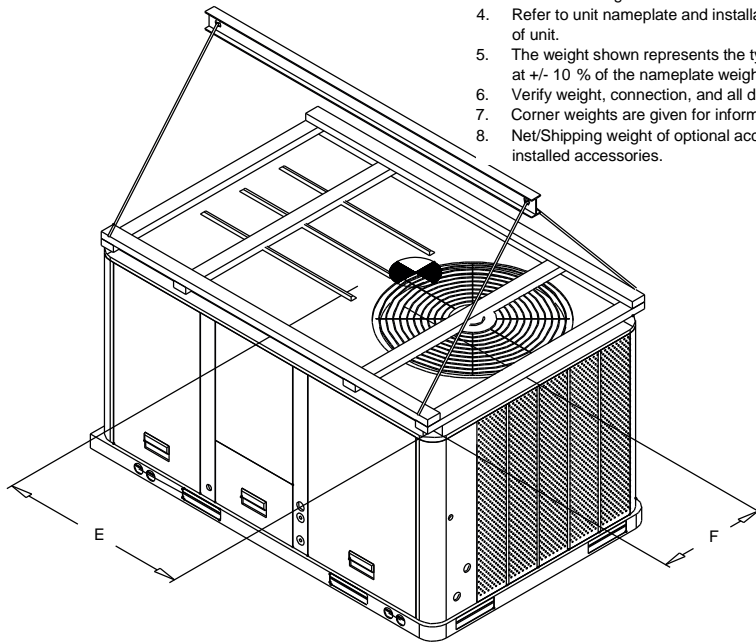

PACKAGED GAS / ELECTRICAL
 RIGGING AND CENTER OF GRAVITY

Weight, Clearance & Rigging Diagram - 3-10 Ton R410A PKGD Unitary Gas/Electric Rooftop
Item: A4 Qty: 1

CLEARANCE FROM TOP OF UNIT 72"

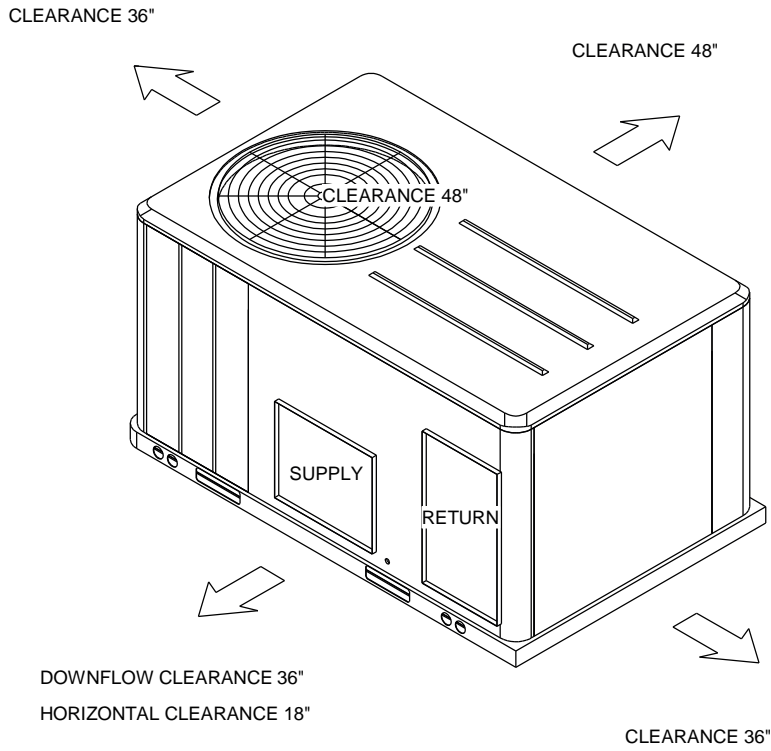

PACKAGED GAS / ELECTRIC

CLEARANCE

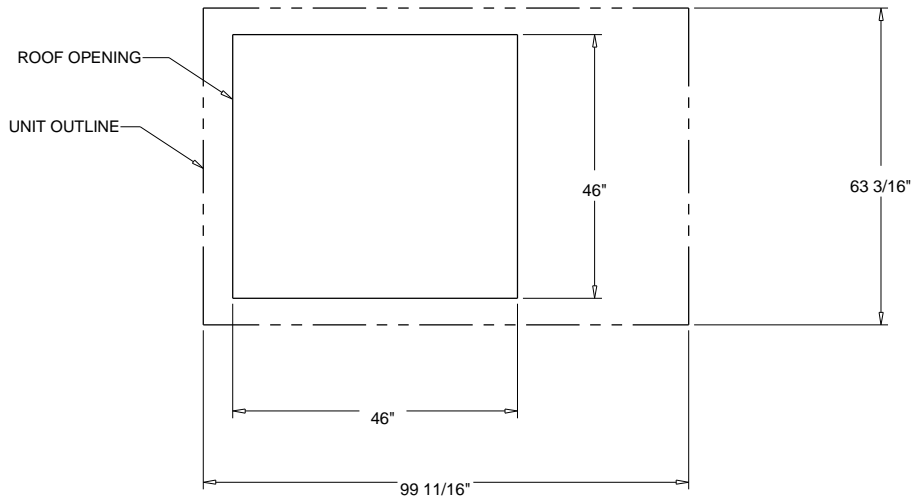

PACKAGED GAS / ELECTRIC

DOWNFLOW TYPICAL ROOF OPENING

Accessory - 3-10 Ton R410A PKGD Unitary Gas/Electric Rooftop
Item: A1 - A3 Qty: 3

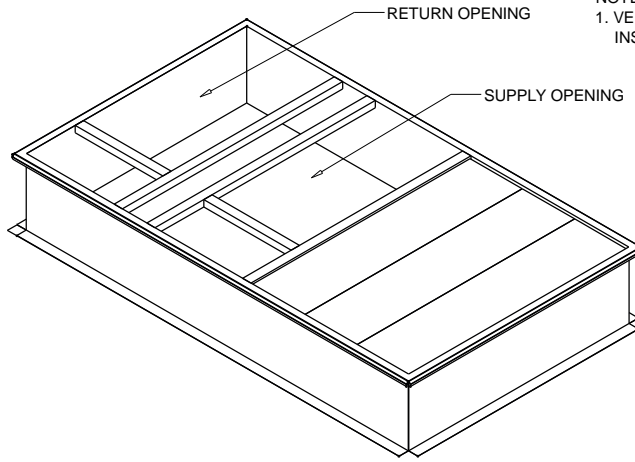

NOTES:
1. VERIFY WEIGHT, CONNECTION, AND ALL DIMENSION WITH
INSTALLER DOCUMENTS BEFORE INSTALLATION

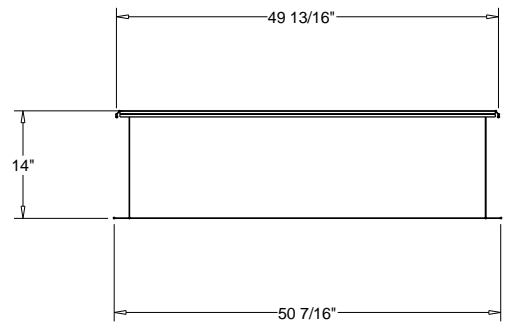
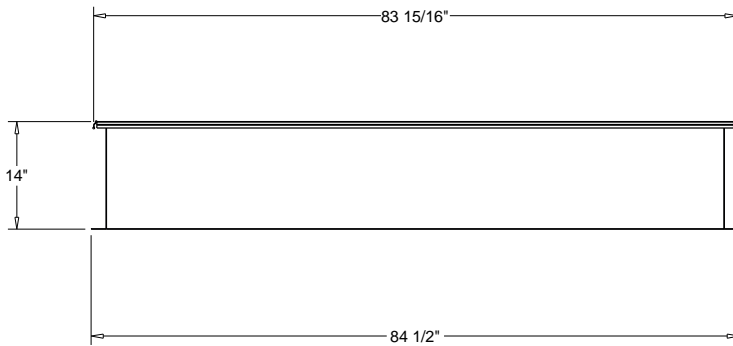
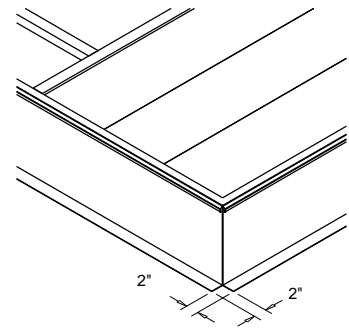
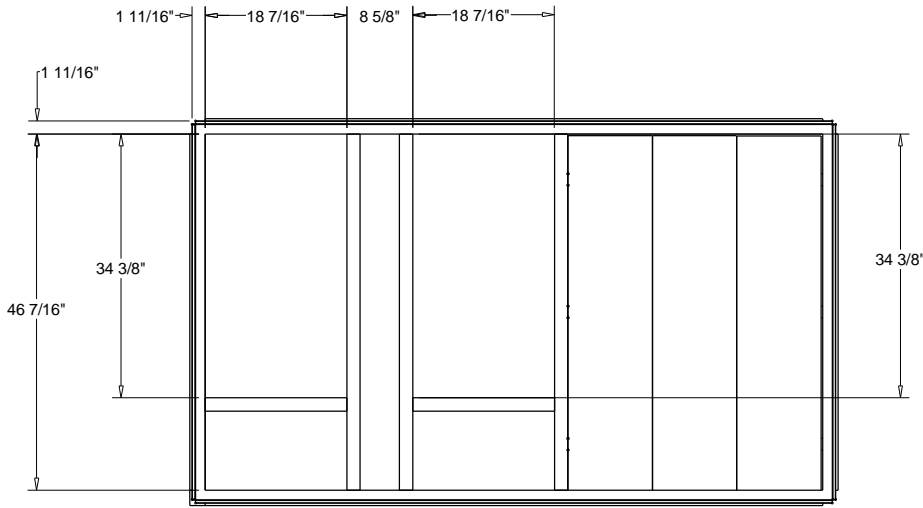

ROOF TOP CURB (BAYCURB043)
ACCESSORY

Accessory - 3-10 Ton R410A PKGD Unitary Gas/Electric Rooftop
Item: A1 - A3 Qty: 3

Downflow Duct Connections - Field Fabricated
All Flanges - 1 1/4"

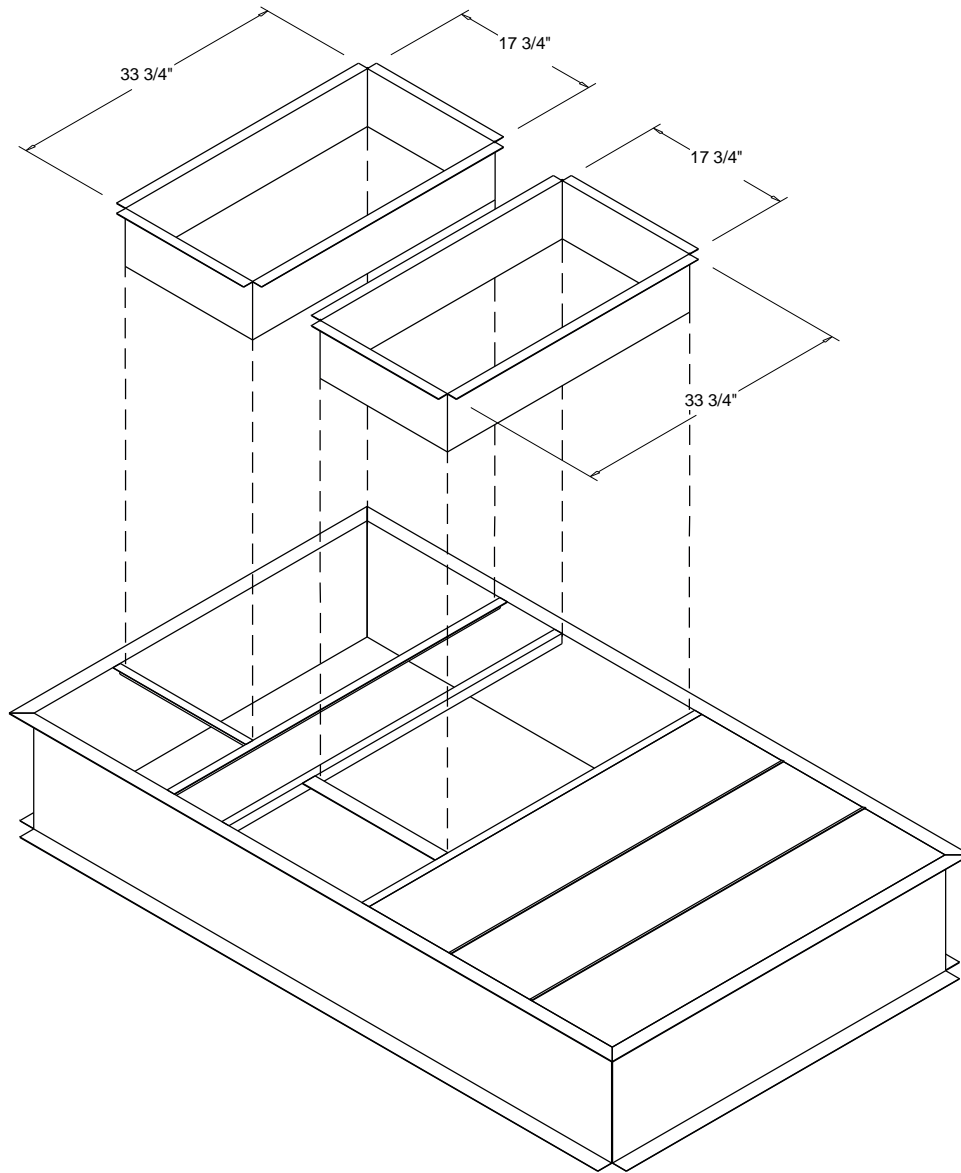

ACCESSORY - DUCT CONNECTIONS

Accessory - 3-10 Ton R410A PKGD Unitary Gas/Electric Rooftop
Item: A1 - A3 Qty: 3

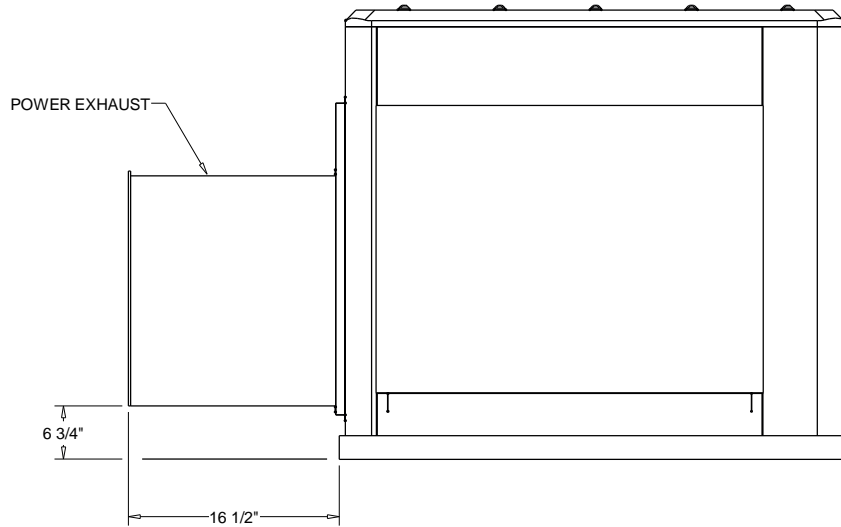
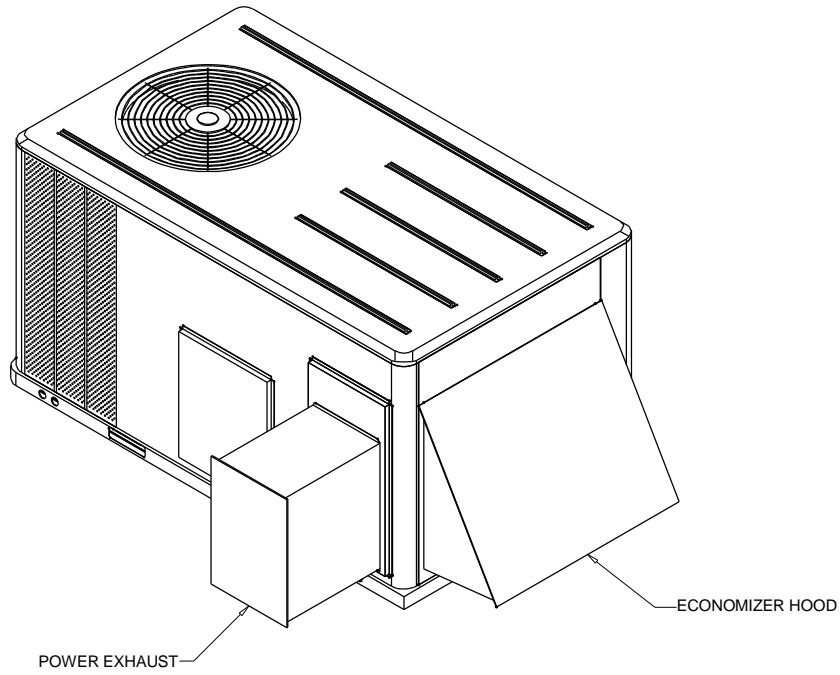

POWER EXHAUST AND HOOD
ACCESSORY

Accessory - 3-10 Ton R410A PKGD Unitary Gas/Electric Rooftop
Item: A1 - A3 Qty: 3

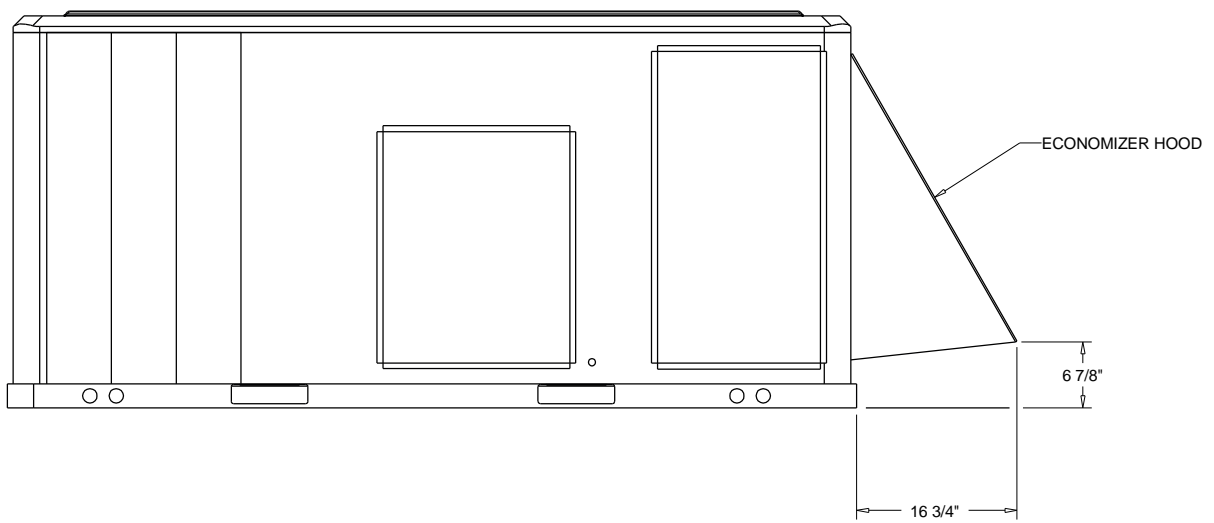
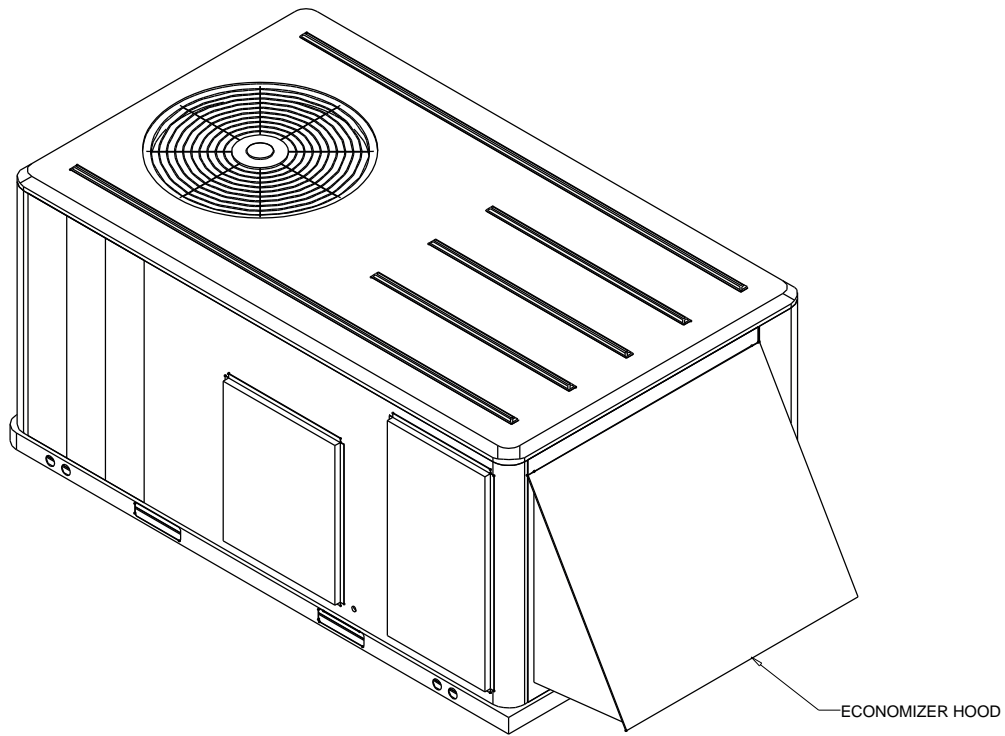

ACCESSORY - ECONOMIZER HOOD

Accessory - 3-10 Ton R410A PKGD Unitary Gas/Electric Rooftop

Item: A4 Qty: 1

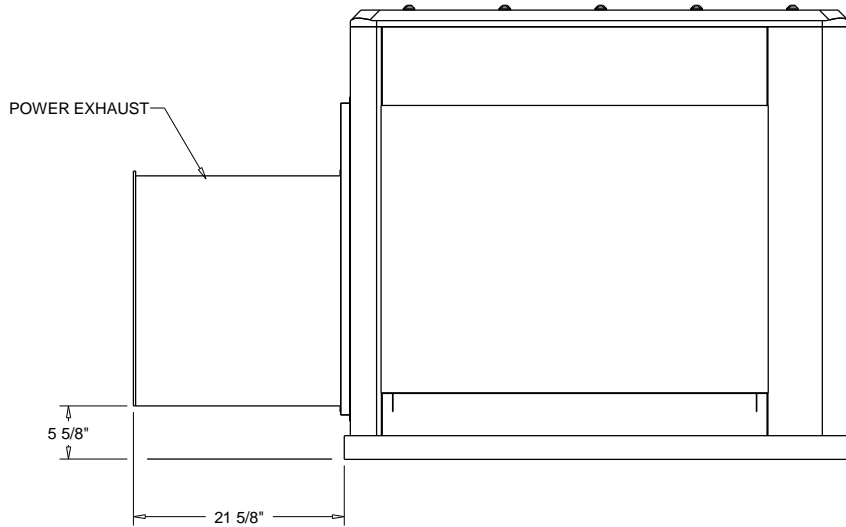
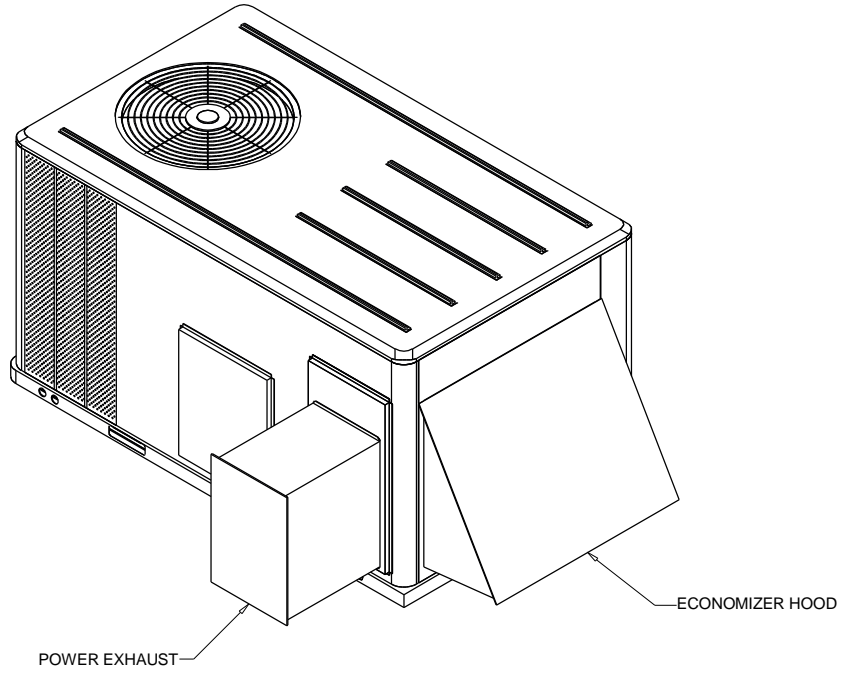

POWER EXHAUST AND HOOD

ACCESSORY

Accessory - 3-10 Ton R410A PKGD Unitary Gas/Electric Rooftop
Item: A4 Qty: 1

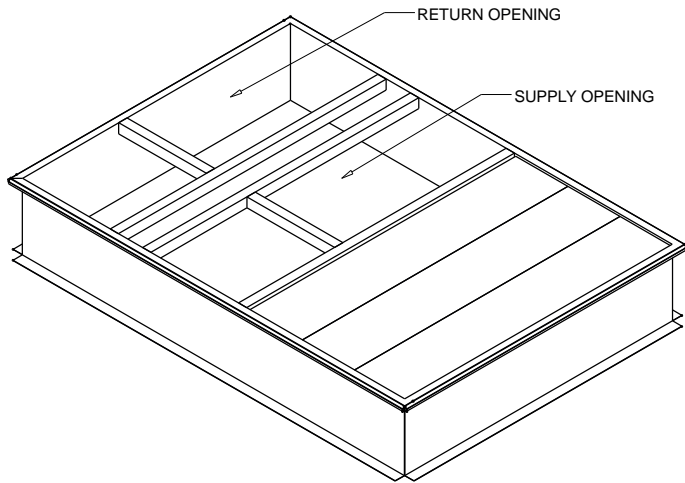

NOTES:
1. VERIFY WEIGHT, CONNECTION, AND ALL DIMENSION WITH
INSTALLER DOCUMENTS BEFORE INSTALLATION

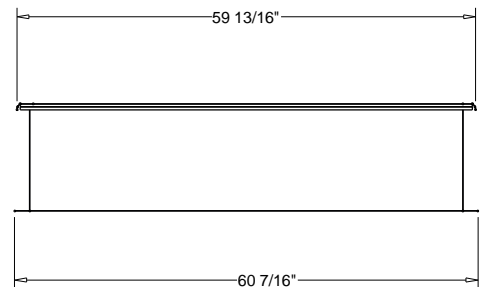
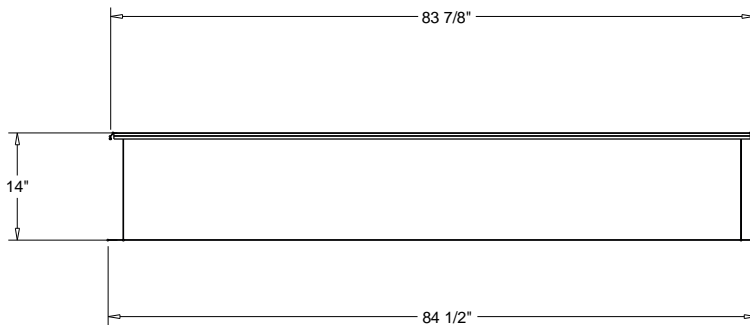
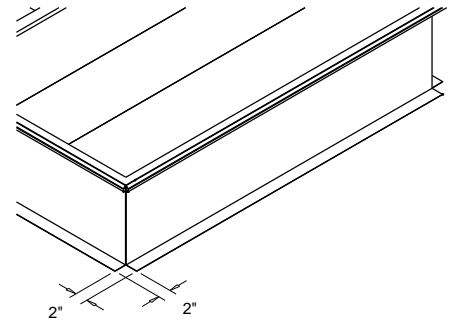
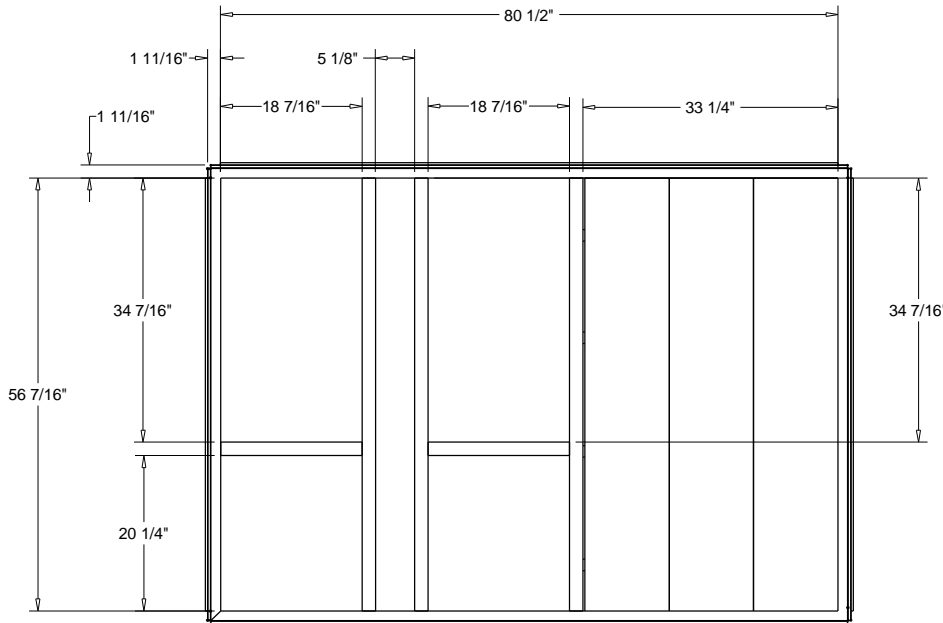

ROOF TOP CURB (BAYCURB044)
ACCESSORY

Accessory - 3-10 Ton R410A PKGD Unitary Gas/Electric Rooftop
Item: A4 Qty: 1

Downflow Duct Connections - Field Fabricated
All Flanges - 1 1/4"

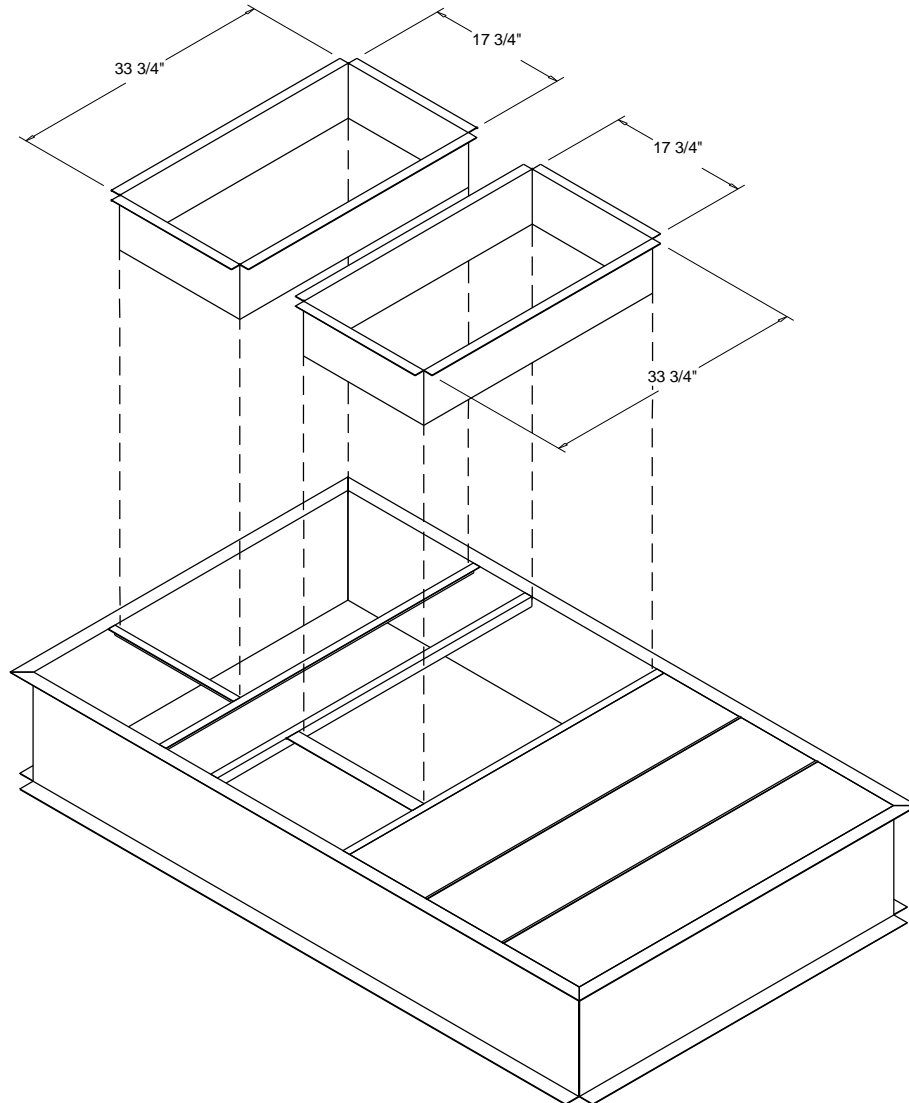

DUCT CONNECTIONS

ACCESSORY

Field Wiring - 3-10 Ton R410A PKGD Unitary Gas/Electric Rooftop
Item: A1 - A4 Qty: 4

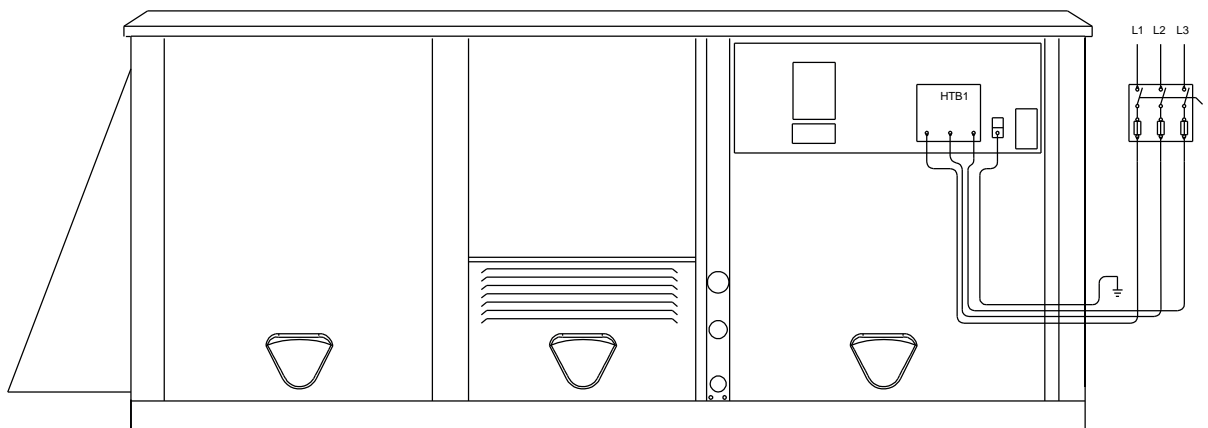

ZONE SENSOR WIRE TABLE

WIRE SIZE	MAXIMUM WIRE LENGTH
22 GAUGE	1800"
20 GAUGE	3000"
18 GAUGE	4500"
16 GAUGE	7200"
14 GAUGE	11700"

NOTE:

1. All wiring and devices shown dashed to be supplied and installed by the customer in accordance with national and local electrical codes.
2. Low voltage control wiring must not be run in conduit with power wiring.

Field Installed Options - Part/Order Number Summary

This is a report to help you locate field installed options that arrive at the jobsite. This report provides part or order numbers for each field installed option, and references it to a specific product tag. It is NOT intended as a bill of material for the job.

Product Family - 3-10 Ton R410A PKGD Unitary Gas/Electric Rooftop

Item	Tag(s)	Qty	Description	Model Number
A1	No Tag	1	7.5 Ton R410A PKGD Unitary Gas/Electric	YHC092F3RLA--C 001A20001A00000 00000000000
A2	No Tag	1	7.5 Ton R410A PKGD Unitary Gas/Electric	YHC092F3RLA--C 001A2A001A0000 00000000000
A3	No Tag	1	8.5 Ton R410A PKGD Unitary Gas/Electric	YHC102F3RLA--C 001A20001A00000 00000000000

Field Installed Option Description	Part/Ordering Number
Power exhaust	BAYPWRX026A
Roof curb	BAYCURB043A

Item	Tag(s)	Qty	Description	Model Number
A4	No Tag	1	10 Ton R410A PKGD Unitary Gas/Electric	YHC120F3RLA--C 001A20001A00000 00000000000

Field Installed Option Description	Part/Ordering Number
Roof curb	BAYCURB044A
Power exhaust	BAYPWRX026A