

PARTITION LEGEND

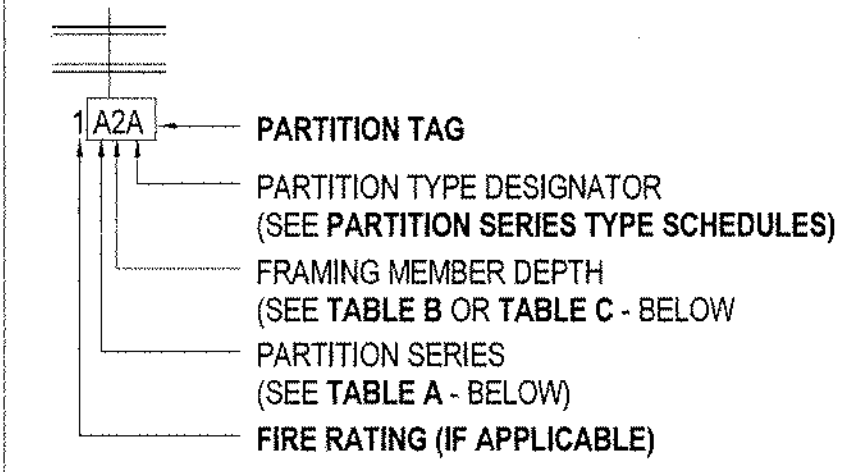

TABLE A - PARTITION SERIES CONSTRUCTION ASSEMBLY

SERIES	SHEATHING	FRAMING MEMBERS	SHEATHING
A	1-LAYER	METAL C-STUD	1-LAYER
B	2-LAYERS	METAL C-STUD	2-LAYERS
C	1-LAYER	METAL C-STUD	2-LAYERS
D	1-LAYER	METAL C-STUD	NONE
E	2-LAYERS	METAL C-STUD	NONE
F	1-LAYER	MTL HAT CHANNEL	NONE
G	1-LAYER	NONE	NONE
H	1-LAYER	METAL C-H STUD	LINER PANEL
J	2-LAYERS	METAL C-H STUD	LINER PANEL
K	1-LAYER	(2) METAL C-STUDS	1-LAYER
L	2-LAYERS	(2) METAL C-STUDS	2-LAYERS
M	NONE	CMU	NONE
N-U	RESERVED FOR FUTURE EXPANSION		
V-Z	CUSTOM	NA	NA

TABLE B - FRAMING DEPTH SCHEDULE

TAG NUMBER	MTL STUD DEPTH	MTL C-H STUD DEPTH	WOOD STUD DEPTH
-	NO FRAMING		
0	7/8" FURRING CHANNEL	N/A	
1	1 5/8"	N/A	
2	2 1/2"	2 1/2"	
3	3 5/8"	N/A	
4	4"	4"	3 1/2"
6	6"	6"	5 1/2"
8	8"	N/A	7 1/4"
10	10"	N/A	9 1/4"

TABLE C - MASONRY WIDTH SCHEDULE

TAG NUMBER	CMU WIDTH
4	3 5/8"
6	5 5/8"
8	7 5/8"
10	9 5/8"
12	11 5/8"

STEEL SHEET THICKNESS FOR STUDS AND RUNNERS

GAGE*	MIN. STEEL BASE METAL THICKNESS (UNCOATED)	INCH	MILS	MM
12	0.1017		97	X
14	0.0713		68	X
16	0.0566		54	1.34
18	0.0451		43	1.09
20	0.0312		30	0.84
22	0.0270		27	0.68
25	0.0179		18	0.45

*GAGE 16, 18 USED FOR STRUCTURAL FRAMING; 20, 22, AND 25 USED FOR NON-STRUCTURAL FRAMING
 *USE OF DIMPLED STEEL STUDS ACCEPTABLE PROVIDED CONTRACTOR SUPPLIES DOCUMENTATION PROVING THE EQUIVALENT MINIMUM BASE METAL THICKNESS IS ACHIEVED
GENERAL NOTES
 GN-01. PARTITION TYPES ARE NOT SEQUENTIAL.
 GN-02. ALL PARTITION SHEATHING TO BE 5/8" GYPSUM BOARD UNLESS OTHERWISE NOTED.
 GN-03. REFER TO A00.410 SERIES FOR TOP OF PARTITION AND A00.420 SERIES FOR BOTTOM OF PARTITION CONDITIONS LISTED IN PARTITION SCHEDULE.
 GN-04. ALL PARTITIONS SHALL BE COORDINATED WITH SCHEDULED FINISHES FOR PARTITION LAYOUT AND REQUIRED CLEARANCES.
 GN-05. PROVIDE BLOCKING IN PARTITIONS FOR ARTWORK HANGING AS INDICATED. SEE CONSTRUCTION PLAN(S) AND/OR INTERIOR ELEVATIONS FOR LOCATIONS.
 GN-06. FOR INTERIOR FRAMING LIMITING HEIGHTS REFER TO S5MA TABLES FOR INTERIOR NON-STRUCTURAL NON-COMPOSITE PARTITIONS
 GN-07. CONTRACTOR TO RE-CONFIRM STUD SIZING AND SUBMIT SELECTION CRITERIA FOR REVIEW INCLUDING DELINEATION OF SLAB TO UNDERSIDE OF SLAB INFORMATION

PARTITION TYPE MARK	FRAMING			DETAILS		ATTEN THK	FIRE RTG	TESTED ASSEMBLY	STC RTG	SHEET NOTES
	THK (IN)	DEPTH	SPACING	TOP	BOT					
B3F	3 5/8"	16" OC	B-T0	B-B0	2	1		2		

3 B SERIES PARTITION TYPES
SCALE: 3" = 1'-0"

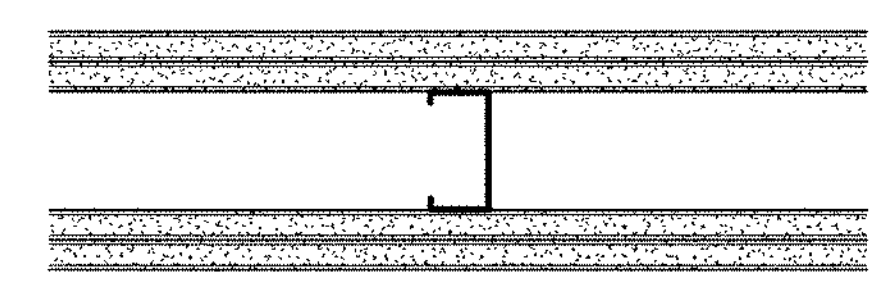

PARTITION TYPE MARK	FRAMING			DETAILS		ATTEN THK	FIRE RTG	TESTED ASSEMBLY	STC RTG	SHEET NOTES
	THK (IN)	DEPT H	SPACING	TOP	BOT					
D2A	2 1/2"		D-T0	D-B0	3	1				
D3A	3 5/8"		D-T0	D-B0	3	1				
D3B	3 5/8"		D-T0	D-B0	2	1				

2 D SERIES PARTITION TYPES
SCALE: 3" = 1'-0"

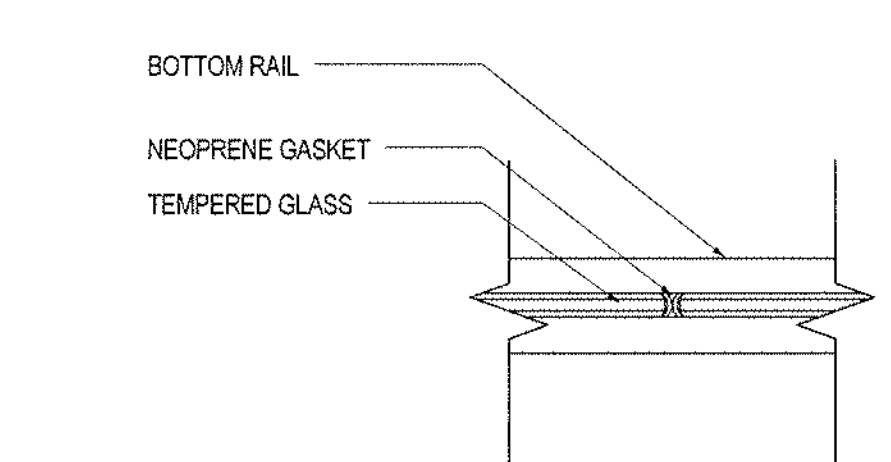
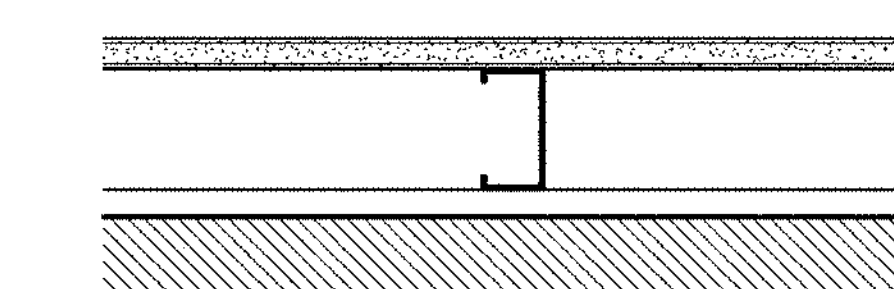

6 GL-2 SERIES PARTITION
SCALE: 3" = 1'-0"

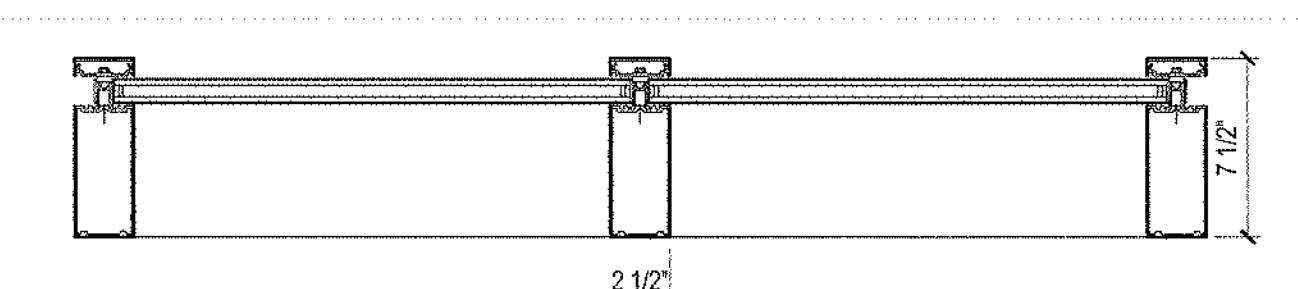

5 GL-1 SERIES PARTITION
SCALE: 1 1/2" = 1'-0"

PARTITION TYPE MARK	FRAMING			DETAILS		ATTEN THK	FIRE RTG	TESTED ASSEMBLY	STC RTG	SHEET NOTES
	THK (IN)	DEPT H	SPACING	TOP	BOT					
A2		2 1/2"								
A3		3 5/8"								
A3A	.027	3 5/8"	16" OC	A-T03	A-B01	3-5/8"				
A3B	.027	3 5/8"	16" OC	A-T02	A-B01	3-5/8"				
A6A		6"	16" OC	A-T03	A-B01	6"				

1 A SERIES PARTITION TYPES
SCALE: 3" = 1'-0"

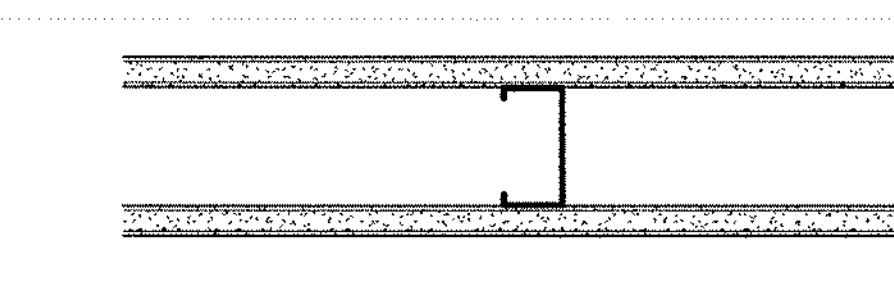

ciee
 Council on International Educational Exchange
 300 Fore Street
 Portland, ME

Gensler
 One Beacon Street
 Third Floor
 Boston MA 02108
 (617) 619-5700
 (617) 619-5701

Date & Issue Description	By	Check
09/16/16 ISSUED FOR PERMIT	ACH	AQ GL

Seal/Signature

Project Name
 CIEE HQ Renovations

Project Number
 11.7086.000

Description
 PARTITION TYPES AND TYPICAL DETAILS

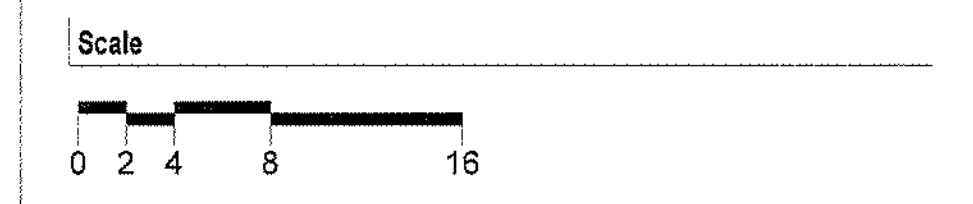

A09.100

© 2016 Gensler