

Franklin
7-17-06

ISSUE:
05/24/06 ISSUED FOR PRICING
07/11/06 ISSUED FOR PERMIT

CUSTOM HOUSE SQUARE
300 FORE STREET
PORTLAND, MAINE
THIRD FLOOR TENANT FIT-UP PLAN

PROJECT ARCHITECT: MW
DRAWN BY: SO
PROJECT #: 300506

A8.3

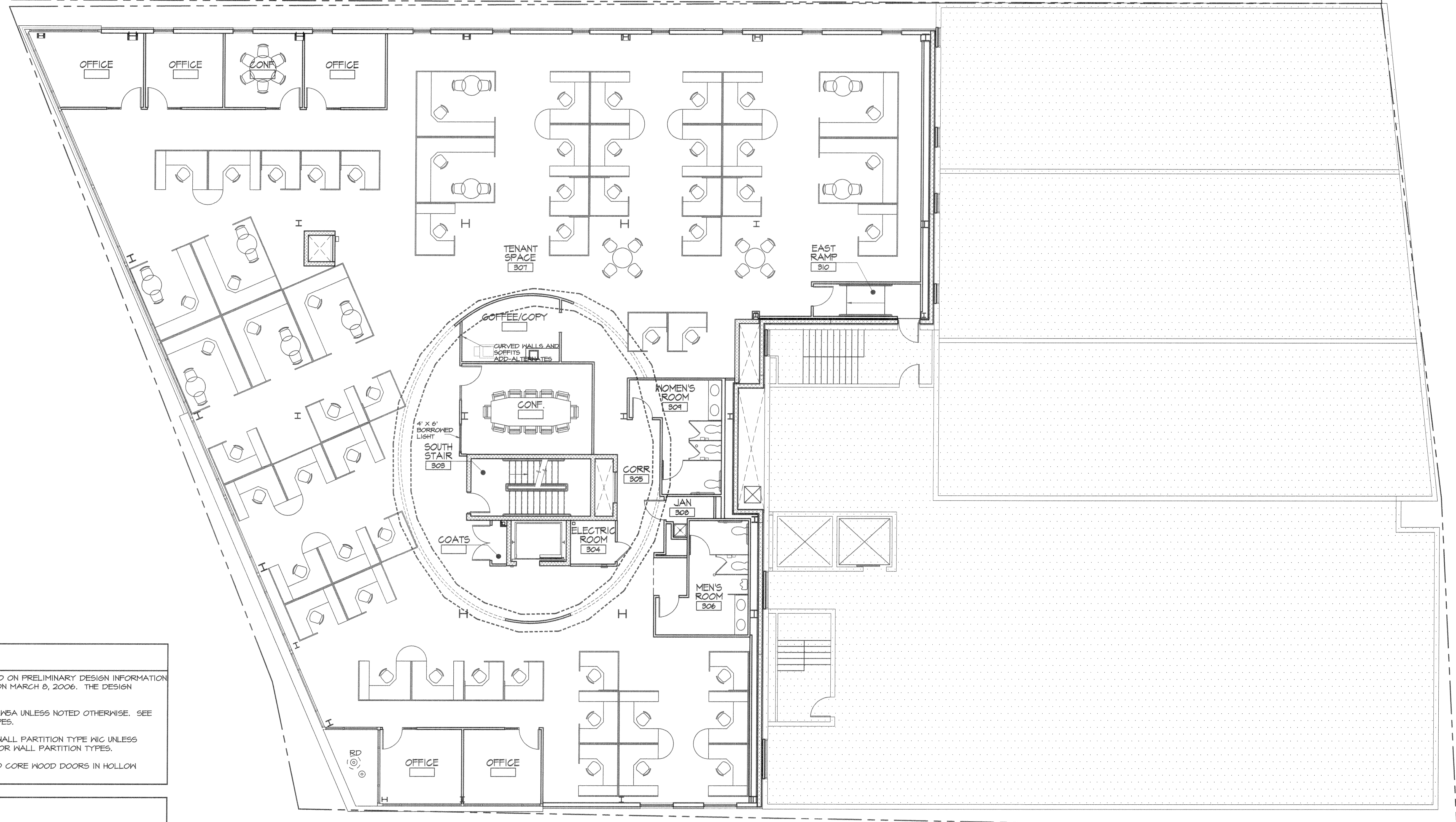

TENANT NOTES

1. TENANT LAYOUT INFORMATION IS BASED ON PRELIMINARY DESIGN INFORMATION PROVIDED BY McMAHON ARCHITECTS ON MARCH 8, 2006. THE DESIGN HAS NOT BEEN FINALIZED.
2. TENANT WALL PARTITIONS TO BE TYPE W5A UNLESS NOTED OTHERWISE. SEE SHEET A4.60 FOR WALL PARTITION TYPES.
3. TENANT STORAGE ROOMS ARE TO BE WALL PARTITION TYPE WIC UNLESS NOTED OTHERWISE. SEE SHEET A4.60 FOR WALL PARTITION TYPES.
4. TENANT DOORS ARE TO BE FLAT SOLID CORE WOOD DOORS IN HOLLOW METAL FRAMES.

GENERAL NOTES

1. FIELD VERIFY ALL DIMENSIONS AND CONDITIONS. PROMPTLY NOTIFY THE ARCHITECT OF ANY ERRORS, OMISSIONS, INCONSISTENCIES OR OTHER PROBLEMS IMMEDIATELY UPON DISCOVERY, AND BEFORE PROCEEDING WITH THE WORK.
2. ALL INDICATIONS AND NOTATIONS ON THE DRAWINGS APPLYING TO ONE AREA, COMPONENT OR CONDITIONS, SHALL APPLY TO ALL OTHER SIMILAR AREAS, COMPONENTS UNLESS CLEARLY INDICATED OTHERWISE.
3. DIMENSIONS ARE TAKEN FROM COLUMN CENTER LINE AND FROM PARTITION CENTER LINE. CLEAR DIMENSIONS ARE TO THE FINISHED FACE OF NEW CONSTRUCTION AND SHALL TAKE PRECEDENCE OVER ANY OTHER DIMENSION.
4. FOR ENLARGED COMMON/CORE AREA PLANS REFER TO SHEETS A2.1 - A2.4.
5. REFER TO SHEETS A4.60 - A4.61 FOR WALL PARTITION TYPES AND RATED ASSEMBLIES.
6. VC.J INDICATES VERTICAL CONTROL JOINTS. ALL JOINTS AT INSIDE CORNERS SHOULD BE PARALLEL WITH THE LENGTH OF THE BUILDING.

NOTE:
TYPICAL LIGHTING IS T5/T8 DIRECT/INDIRECT PENDANT LIGHTING FIXTURES. CONFERENCE AND TRAINING ROOMS SHALL HAVE UPGRADED LIGHTING WITH CAN LIGHTS/ WALL WASHERS AND DIMMER SWITCHES.

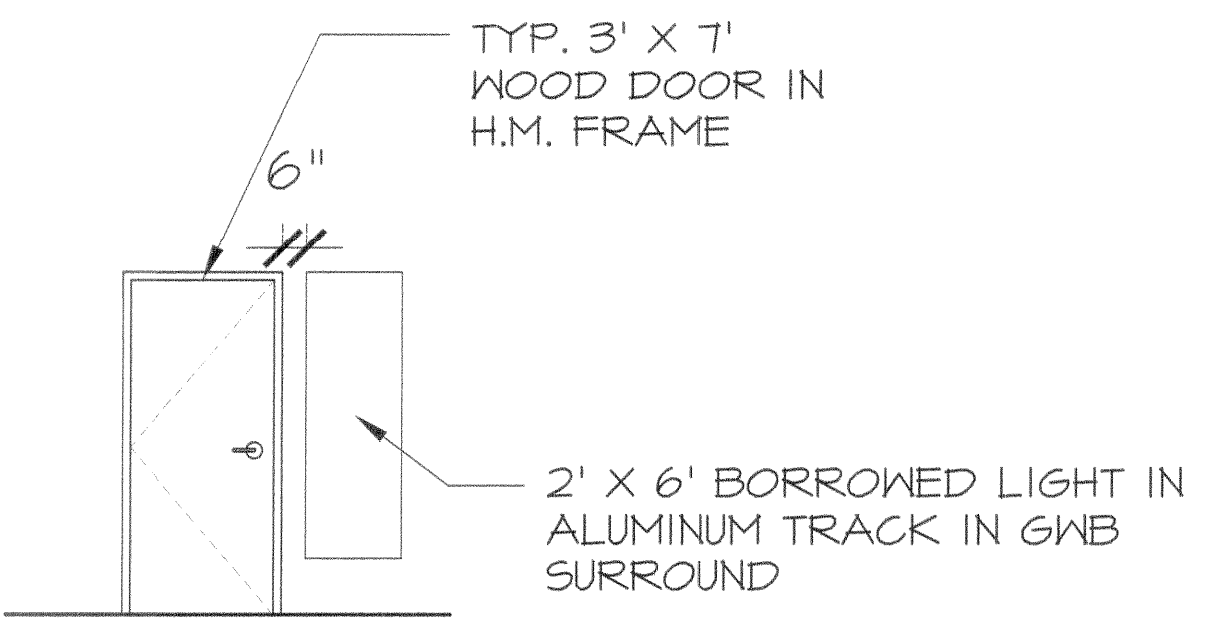

TYPICAL OFFICE/CONFERENCE ENTRANCE

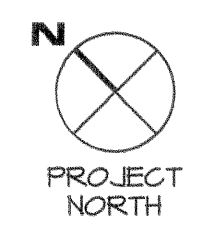

THIRD FLOOR TENANT FIT-UP PLAN

SCALE: 1/8" = 1'-0"