

ABBREVIATIONS, LINE TYPES & SYMBOLS

I40	I40 DEG F HOT WATER	IE	INVERT ELEVATION	---	SANITARY / WASTE PIPING BELOW SLAB
@	AT	IDW	INDIRECT WASTE	---	SANITARY / WASTE PIPING ABOVE SLAB
A	AMPS, AQUASTAT	IM	ICE MAKER	---	INDIRECT WASTE PIPING ABOVE SLAB
ADA	AMERICANS WITH DISABILITIES ACT	LV	LAVATORY	---	VENT PIPING ABOVE SLAB
AFF	ABOVE FINISHED FLOOR	MB	MOP BASIN	---	VENT PIPING BELOW SLAB
BFP	BACKFLOW PREVENTER	MTD	MOUNTED	---	COLD WATER PIPING
BLV	BALL VALVE	MV	MIXING VALVE	---	COLD WATER PIPING BELOW SLAB
BV	BALANCE VALVE	NB	NICKEL BRONZE	---	TRAP PRIMER PIPING
CNTR	COUNTER	OD	OUTSIDE DIAMETER	---	TRAP PRIMER PIPING BELOW SLAB
CO	CLEANOUT	PC	PLUMBING CONTRACTOR	---	120 HOT WATER PIPING
CONT	CONTINUATION	PDI	PLUMBING & DRAINAGE INSTITUTE	---	HOT WATER RETURN PIPING
CORD	COORDINATION	PRV	PRESSURE REDUCING VALVE	---	140 HOT WATER PIPING
COG	CLEANOUT TO GRADE	PSI	POUNDS PER SQUARE INCH	---	GAS PIPING
CW	COLD WATER	PSI	POUNDS PER SQUARE INCH	---	RADON PIPING BELOW SLAB
CHW	COLD & HOT WATER	PW	PUMPED WASTE	---	
DAW	DROP AT WALL	RAW	RISE AT WALL	---	
DCP	DOMESTIC CIRCULATING PUMP	RH	RIGHT HAND	---	BALL VALVE
DIC	DROP IN CHASE	RIG	RISE IN CHASE	---	VERTICAL BALL VALVE
DIW	DROP IN WALL	RIW	RISE IN WALL	---	BALANCING VALVE
DN	DOWN	RUC	RUN UNDER COUNTER	---	CHECK VALVE
DN.	DOWN AND UP	RUFF	RUN UNDER FLOOR	---	BACKFLOW PREVENTER
DNAW	DOWN AT WALL	R	RELIEF VALVE	---	VACUUM RELIEF VALVE
DNIC	DOWN IN CHASE	SA	SANITARY WASTE	---	RELIEF VALVE
DNW	DOWN IN WALL	S	SHOCK ABSORBER	---	PRESSURE REDUCING VALVE
DO	DRAWOFF	SH	SHOWER	---	THERMOMETER
DW	DISHWASHER	SK	SINK	---	PRESSURE GAUGE
EA	EACH	SS	STAINLESS STEEL	---	TRAP PRIMER
ET	EXPANSION TANK	T	THERMOMETER	---	TYPICAL
FCO	FLOOR CLEANOUT	TP	TRAP PRIMER	---	DROP/RISE IN LINE
FD	FLOOR DRAIN	TYP	TYPICAL	---	LINE UP TO FLOOR ABOVE
FFE	FINISHED FLOOR ELEVATION	UIC	UP IN CHASE	---	TEE -DROP
G	GAS (FUEL)	U&DNIC	UP & DOWN IN WALL	---	SHOCK ABSORBER
GAL	GALLONS	UW	UP IN WALL	---	UNION
GC	GENERAL CONTRACTOR	UR	URINAL	---	MIXING VALVE
GHT	GARDEN HOSE THREAD	V	VENT	---	FLOOR CLEANOUT
GPF	GALLONS PER FLUSH	VB	VACUUM BREAKER	---	FLOOR DRAIN
GPM	GALLONS PER MINUTE	VC	VITREOUS CHINA	---	WALL CLEANOUT
GV	GATE VALVE	VIF	VERIFY IN FIELD	---	VENT THROUGH ROOF
HB	HOSE BIB	VRV	VACUUM RELIEF VALVE	---	HOSE BIB
HC	HEATING CONTRACTOR	VTR	VENT THRU ROOF	---	PLUMBING FIXTURE/EQUIPMENT NUMBER TAG
HW	HOT WATER	W	WASTE	---	
HWB	HOT WATER RETURN	W	WASTE	---	
		WB	WATER (SUPPLY) BOX	---	
		WC	WATER CLOSET, WATER COLUMN	---	
		WCO	WALL CLEANOUT	---	

PLUMBING FIXTURE SCHEDULE

TAG	FIXTURE	COLD WATER	120° WATER	SAN/WASTE	VENT	REMARKS	MOUNTING HEIGHT
DW-1	DISHWASHER UNDER COUNTER		1/2"	1-1/2"	1-1/2"	APPLIANCE BY OTHERS	
IM-1	ICE MAKER	1/2"		IDW		WATER SUPPLY BOX	
LV-1	LAVATORY, WALL MTD ADA	1/2"	1/2"	1-1/4" x 1-1/2"	1-1/2"	VC, SINGLE HANDLE FAUCET WALL CARRIER	RIM 34"
LV-2	LAVATORY, COUNTERTOP ADA	1/2"	1/2"	1-1/4" x 1-1/2"	1-1/2"	OVAL VC, SINGLE HANDLE FAUCET	COUNTER 34" VIF
MB-1	MOP BASIN	1/2"	1/2"	3"	1-1/2"	FLOOR MTD, MOLDED STONE 24"x24"x10", VB FAUCET	FLOOR
SK-2	SINK, DOUBLE BOWL ADA	1/2"	1/2"	1-1/2"	1-1/2"	S.S. UNDERMOUNT KITCHEN FAUCET W/ PULL OUT SPRAY	COUNTER 34" VIF
UR-1	URINAL, FLUSH VALVE, WALL MTD	1"	2"	1-1/2"		0.125 GPF, VC	RIM 24"
WB-1	WATER SUPPLY BOX	1/2"				FOR WATER DISPENSER REFRIGERATOR AND COFFEE MAKER	AS NEEDED
WC-1	WATER CLOSET, TANK FLOOR MTD	1/2"		4"	2"	1.6 GPF, VC, 15" TO RIM	FLOOR
WC-2	WATER CLOSET, TANK FLOOR MTD - ADA	1/2"		4"	2"	1.6 GPF, VC, 16-1/8" TO RIM	FLOOR
WC-3	WATER CLOSET, RH TANK FLOOR MTD - ADA	1/2"		4"	2"	1.6 GPF, VC, 16-1/8" TO RIM, RIGHT HAND HANDLE	FLOOR

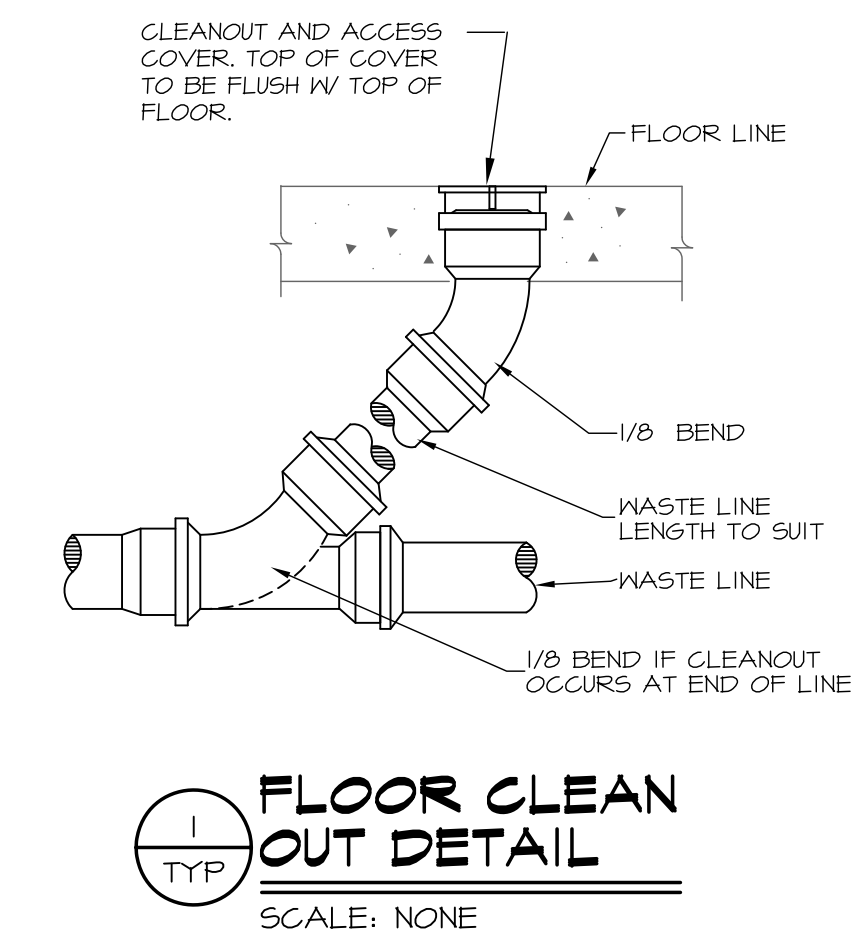

PUMP SCHEDULE

TAG	ITEM	SERVICE	GPM	HEAD FT	HP	RPM	VOLTS	REMARKS
DCP-1	DOMESTIC RECIRC PUMP	120° HW RECIRC LOOP	3	5	1/40	-	115	3/4" BRONZE ELEG. BY DIV. 16

WATER SPEC. SCHEDULE

TAG	ITEM	CW	HW	OUTLET	REMARKS
MV-1	MASTER MIXING VALVE	3/4"	3/4"	3/4"	120°
SA-1	SHOCK ABSORBER	1/2" OR 3/4"	-	-	P.D.I. A
TP-1	TRAP SEAL PRIMER W/ SPLITTER AS REQUIRED	1/2"	-	SAME	

DRAIN SPEC. SCHEDULE

TAG	ITEM	WASTE	VENT	REMARKS
FCO-1	ROUND - FINISHED AREAS FLOOR CLEANOUT	SIZE OF PIPE	-	
FD-1	GENERAL ROUND FLOOR DRAIN	3"	1-1/2"	
FD-2	RECESSED GRATE ROUND FLOOR DRAIN	3"	1-1/2"	

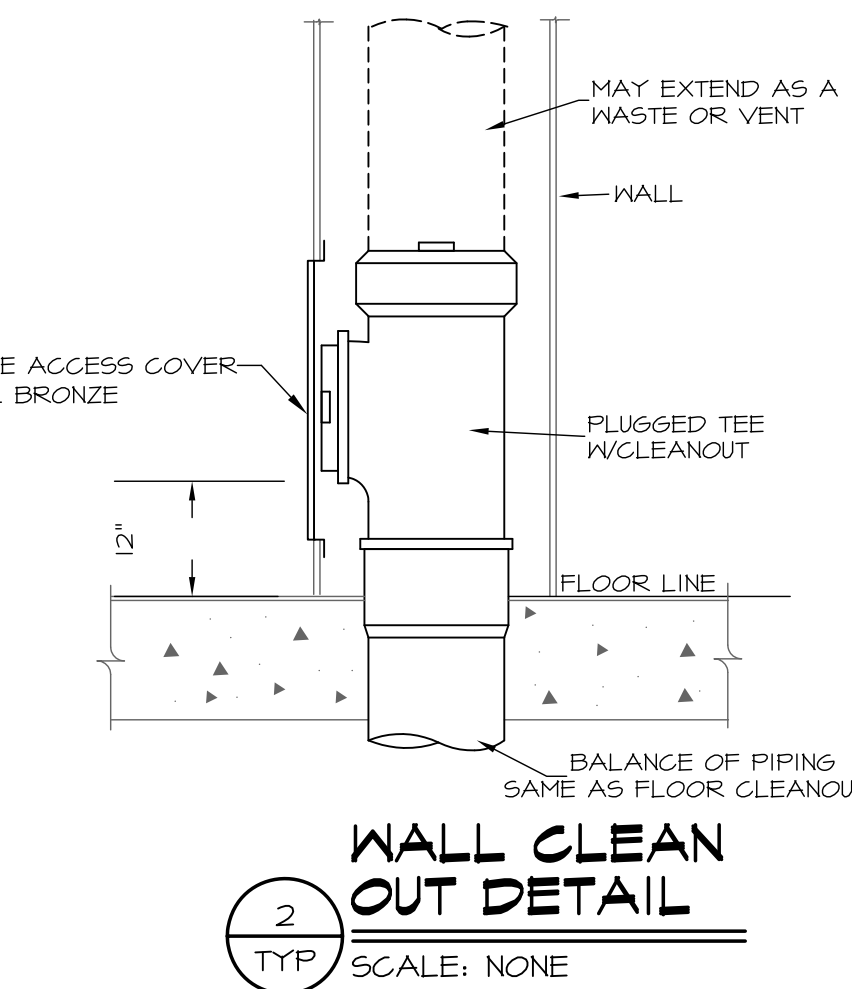
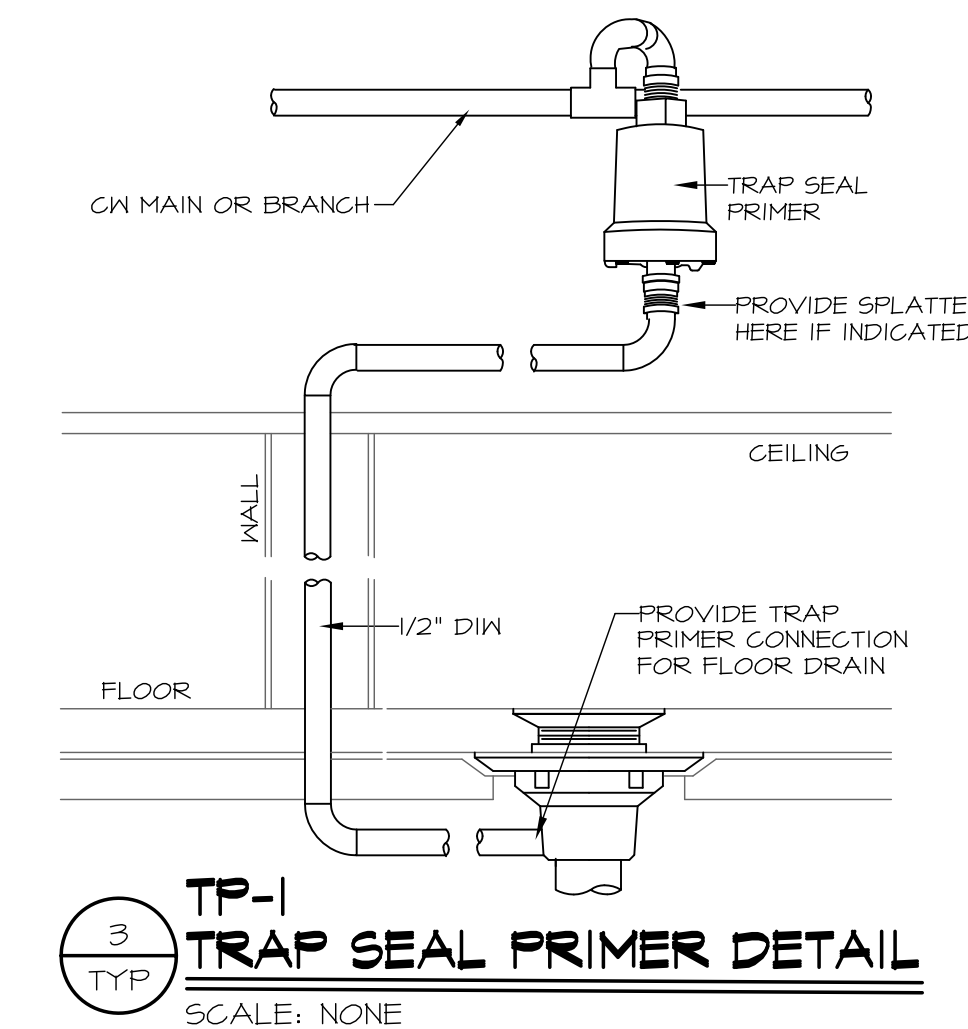

WINTON SCOTT ARCHITECTS
5 Milk Street
Portland, Maine 04101
207 774 4811
www.wintonscott.com

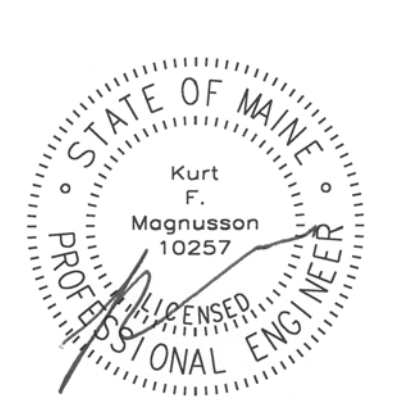

Branding / Bank Branch Interior Design:
THE ELEMENT GROUP
125 Brewery Lane
Suite #9
Portsmouth, NH 03801
T. 603.319.8951

Structural Engineering:
STRUCTURAL INTEGRITY ENGINEERS
77 Oak Street
Portland, ME 04101
T. 207.774.4614

HVAC & plumbing Engineering:
MECHANICAL SYSTEMS ENGINEERS
Royal River Center, Unit 10B
10 Forest Falls Drive
Yarmouth, ME 04096
T. 207.846.1441

Electrical Engineering:
SWIFT CURRENT ENGINEERING
Royal River Center, Unit 4B
10 Forest Falls Drive
Yarmouth, ME 04096
T. 207.847.9280



Portland Branch
27 Pearl Street
1st Floor Tenant Space
Portland, Maine

FOR CONSTRUCTION
March 04, 2015

PLUMBING SCHEDULES

Scale: NONE

P3

MECHANICAL SYSTEMS ENGINEERS
ROYAL RIVER CENTER, UNIT #10B
10 FOREST FALLS DRIVE
YARMOUTH, MAINE 04096
FACEBOOK: MECHANICAL SYSTEMS ENGINEERS
207-846-1441
M.S.E. Proj. 1437
© COPYRIGHT 2015

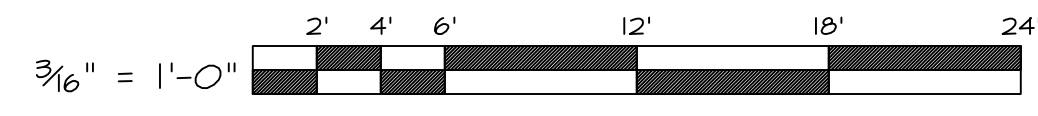

March 05, 2015 - 11:36 am
\\MESEFS1\shared\Projects\1437 - Northeast Bank\Drawings\1437-P1-P3.dwg