

DISPLAY THIS CARD ON PRINCIPAL FRONTAGE OF WORK

CITY OF PORTLAND

BUILDING INSPECTION PERMIT

Please Read
Application And
Notes, If Any,
Attached

PERMIT ISSUED
Permit Number: 070014
FEB - 1 2007
CITY OF PORTLAND

This is to certify that RSB LIMITED LIABILITY COMPANY /National Air & R

has permission to Install additional 12ft hood and vent to rear of building

AT 129 COMMERCIAL ST

BL 029 D001001

provided that the person or persons, firm or corporation accepting this permit shall comply with all of the provisions of the Statutes of Maine and of the Ordinances of the City of Portland regulating the construction, maintenance and use of buildings and structures, and of the application on file in this department.

Apply to Public Works for street line and grade if nature of work requires such information.

Notification of inspection must be given and written permission procured before this building or part thereof is opened or otherwise closed-in. 24 HOUR NOTICE IS REQUIRED.

A certificate of occupancy must be procured by owner before this building or part thereof is occupied.

OTHER REQUIRED APPROVALS

Fire Dept. _____

Health Dept. _____

Appeal Board _____

Other _____
Department Name

Jeanne Bouk 2/1/07
Director - Building & Inspection Services

PENALTY FOR REMOVING THIS CARD

Scanned



CITY OF PORTLAND, MAINE
Department of Building Inspections

_____ 20 07

Received from Commercial Air Products

Location of Work 107 Commercial St.

Cost of Construction \$ 3000

Permit Fee \$ 50

Building (IL) Plumbing (I5) Electrical (I2) Site Plan (U2)

Other Wood

CBL: 09 P 001

Check #: 752 Total Collected \$ 3050

THIS IS NOT A PERMIT

No work is to be started until PERMIT CARD is actually posted upon the premises. Acceptance of fee is no guarantee that permit will be granted. PRESERVE THIS RECEIPT. In case permit cannot be granted the amount of the fee will be refunded upon return of the receipt less \$10.00 or 10% whichever is greater.

WHITE - Applicant's Copy
YELLOW - Office Copy
PINK - Permit Copy

City of Portland, Maine - Building or Use Permit Application

389 Congress Street, 04101 Tel: (207) 874-8703, Fax: (207) 874-8716

Permit No: 07-0014	Issue Date:	CBL: 029 D001001
-----------------------	-------------	---------------------

Location of Construction: 129 COMMERCIAL ST	Owner Name: RSB LIMITED LIABILITY COMP	Owner Address: 32 PYA RD	Phone:
Business Name:	Contractor Name: National Air & Ref.	Contractor Address: 173 Indian Village Road Shapliegh	Phone 2076152891
Lessee/Buyer's Name	Phone:	Permit Type: Alterations - Commercial	Zone: B3

Past Use: Commercial / Restaraunt - <i>Roby's</i> <i>Crab Louie's</i>	Proposed Use: Commercial / Restaraunt install additional 12ft hood and vent to rear of bldg.	Permit Fee:	Cost of Work: \$0.00	CEO District: 1
		FIRE DEPT: <input checked="" type="checkbox"/> Approved <input type="checkbox"/> Denied <i>To NFPA 96</i>	INSPECTION: Use Group: <i>A1</i> Type: <i>Hood</i>	

Proposed Project Description: Install additional 12ft hood and vent to rear of bldg.	Signature: <i>Greg Cross</i>	Signature: <i>JMB 2/1/07</i>
PEDESTRIAN ACTIVITIES DISTRICT (P.A.D.)		
Action: <input type="checkbox"/> Approved <input type="checkbox"/> Approved w/Conditions <input type="checkbox"/> Denied		
Signature: _____ Date: _____		

Permit Taken By: dmartin	Date Applied For: 01/04/2007	Zoning Approval
-----------------------------	---------------------------------	------------------------

- This permit application does not preclude the Applicant(s) from meeting applicable State and Federal Rules.
- Building permits do not include plumbing, septic or electrical work.
- Building permits are void if work is not started within six (6) months of the date of issuance. False information may invalidate a building permit and stop all work..

Special Zone or Reviews <input type="checkbox"/> Shoreland <input type="checkbox"/> Wetland <input type="checkbox"/> Flood Zone <input type="checkbox"/> Subdivision <input type="checkbox"/> Site Plan Maj <input type="checkbox"/> Minor <input type="checkbox"/> MM <input type="checkbox"/> Date: <i>1/14/07</i> <i>AM</i>	Zoning Appeal <input type="checkbox"/> Variance <input type="checkbox"/> Miscellaneous <input type="checkbox"/> Conditional Use <input type="checkbox"/> Interpretation <input type="checkbox"/> Approved <input type="checkbox"/> Denied Date: _____	Historic Preservation <i>yes</i> <input type="checkbox"/> Not in District or Landmark <input type="checkbox"/> Does Not Require Review <input type="checkbox"/> Requires Review <input type="checkbox"/> Approved <input checked="" type="checkbox"/> Approved w/Conditions <input type="checkbox"/> Denied Date: <i>D. Andrews</i> <i>1/19/07</i>
--	---	--

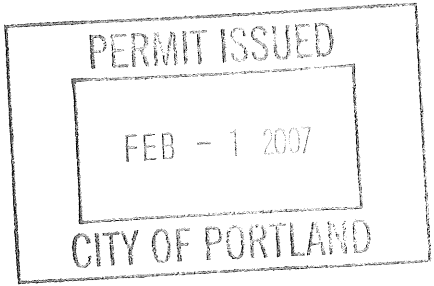

CERTIFICATION

I hereby certify that I am the owner of record of the named property, or that the proposed work is authorized by the owner of record and that I have been authorized by the owner to make this application as his authorized agent and I agree to conform to all applicable laws of this jurisdiction. In addition, if a permit for work described in the application is issued, I certify that the code official's authorized representative shall have the authority to enter all areas covered by such permit at any reasonable hour to enforce the provision of the code(s) applicable to such permit.

SIGNATURE OF APPLICANT	ADDRESS	DATE	PHONE
RESPONSIBLE PERSON IN CHARGE OF WORK, TITLE		DATE	PHONE

BUILDING PERMIT INSPECTION PROCEDURES

Please call 874-8703 or 874-8693 to schedule your inspections as agreed upon

Permits expire in 6 months, if the project is not started or ceases for 6 months.

The Owner or their designee is required to notify the inspections office for the following inspections and provide adequate notice. Notice must be called in 48-72 hours in advance in order to schedule an inspection:

By initializing at each inspection time, you are agreeing that you understand the inspection procedure and additional fees from a "Stop Work Order" and "Stop Work Order Release" will be incurred if the procedure is not followed as stated below.

A Pre-construction Meeting will take place upon receipt of your building permit.

- Footing/Building Location Inspection: Prior to pouring concrete
- Re-Bar Schedule Inspection: Prior to pouring concrete
- Foundation Inspection: Prior to placing ANY backfill
- Framing/Rough Plumbing/Electrical: Prior to any insulating or drywalling
- Final/Certificate of Occupancy: Prior to any occupancy of the structure or use. NOTE: There is a \$75.00 fee per inspection at this point.

Certificate of Occupancy is not required for certain projects. Your inspector can advise you if your project requires a Certificate of Occupancy. All projects **DO** require a final inspection

If any of the inspections do not occur, the project cannot go on to the next phase, **REGARDLESS OF THE NOTICE OR CIRCUMSTANCES.**

N/A **CERIFICATE OF OCCUPANICES MUST BE ISSUED AND PAID FOR, BEFORE THE SPACE MAY BE OCCUPIED**

Signature of Applicant/Designee

Date

Signature of Inspections Official

Date

CBL: 29-D-1

Building Permit #: 07-0075 & 07-0014

City of Portland, Maine - Building or Use Permit

389 Congress Street, 04101 Tel: (207) 874-8703, Fax: (207) 874-8716

Permit No: 07-0014	Date Applied For: 01/04/2007	CBL: 029 D001001
------------------------------	--	----------------------------

Location of Construction: 129 COMMERCIAL ST	Owner Name: RSB LIMITED LIABILITY COMP	Owner Address: 32 PYA RD	Phone:
Business Name:	Contractor Name: National Air & Ref.	Contractor Address: 173 Indian Village Road Shapliegh	Phone: (207) 615-2891
Lessee/Buyer's Name	Phone:	Permit Type: Hood Systems, Commerical	

Proposed Use: Commercial / Restaurant install additional 12ft hood and vent to rear of bldg.	Proposed Project Description: Install additional 12ft hood and vent to rear of bldg.
--	--

Dept: Historic **Status:** Approved with Conditions **Reviewer:** Deborah Andrews **Approval Date:** 01/19/2007
Note: **Ok to Issue:**

- 1) * New vent to align vertically with the existing vent at rear of building and be framed in same way as existing.

Dept: Zoning **Status:** Approved with Conditions **Reviewer:** Ann Machado **Approval Date:** 01/04/2007
Note: **Ok to Issue:**

- 1) ANY exterior work requires a separate review and approval thru Historic Preservation. This property is located within an Historic District.
2) This permit is being approved on the basis of plans submitted. Any deviations shall require a separate approval before starting that work.

Dept: Building **Status:** Approved with Conditions **Reviewer:** Jeanine Bourke **Approval Date:** 02/01/2007
Note: **Ok to Issue:**

- 1) Fire rated ceiling tile specs must be submitted prior to the installation
2) Permit approved based on the plans submitted and reviewed w/owner/contractor, with additional information as agreed on and as noted on plans.

Dept: Fire **Status:** Approved with Conditions **Reviewer:** Cptn Greg Cass **Approval Date:** 01/22/2007
Note: **Ok to Issue:**

- 1) Install shall comply with NFPA 96

Comments:

1/31/2007-jmb: Mike Iosha came in to give more details on plans, still have questions

2/1/2007-jmb: Spoke w/ Mike I. As noted on plans, ok to issue

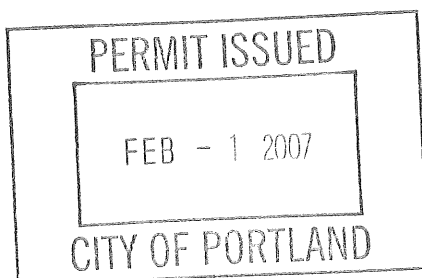



General Building Permit Application

If you or the property owner owes real estate or personal property taxes or user charges on any property within the City, payment arrangements must be made before permits of any kind are accepted.

Location/Address of Construction: <u>127 Commercial (Rubys)</u>		
Total Square Footage of Proposed Structure	Square Footage of Lot	
Tax Assessor's Chart, Block & Lot Chart# Block# Lot# <u>X 29 D 001</u>	Owner: <u>Mike Keon</u>	Telephone: <u>978 886 0873</u>
Lessee/Buyer's Name (If Applicable) <u>Mike Keon</u>	Applicant name, address & telephone: <u>NATIONAL AIR + REF 173 Indian Village Shapleigh Me</u>	Cost Of Work: \$ <u>3000.-</u> Fee: \$ _____ C of O Fee: \$ _____
Current Specific use: <u>RESTAURANT (Rubys)</u> If vacant, what was the previous use? _____ Proposed Specific use: _____		
Project description: <u>INSTALL additional 12' Hood and vent to REAR OF BUILDING</u>		
Contractor's name, address & telephone: <u>MIKE LOSCA NATIONAL AIR + REF 173 Indian Village Shapleigh Me 04076</u> Who should we contact when the permit is ready: Mailing address: _____ Phone: <u>207-615-2891</u>		

Please submit all of the information outlined in the Commercial Application Checklist. Failure to do so will result in the automatic denial of your permit.

In order to be sure the City fully understands the full scope of the project, the Planning and Development Department may request additional information prior to the issuance of a permit. For further information visit us on-line at www.portlandmaine.gov, stop by the Building Inspections office, room 315 City Hall or call 874-8703.

I hereby certify that I am the Owner of record of the named property, or that the owner of record authorizes the proposed work and that I have been authorized by the owner to make this application as his/her authorized agent. I agree to conform to all applicable laws of this jurisdiction. In addition, if a permit for work described in this application is issued, I certify that the Code Official's authorized representative shall have the authority to enter all areas covered by this permit at any reasonable hour to enforce the provisions of the codes applicable to this permit.

[Handwritten Signature]
Signature of applicant:

Date: 1-4-07

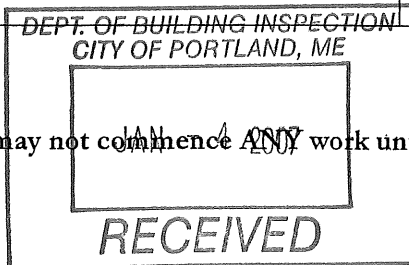

This is not a permit; you may not commence ANY work until the permit is issued.

[Handwritten Signature]

Ceiling to 2nd Floor Empty space
 2 layers of sheet rock on second floor floor joists

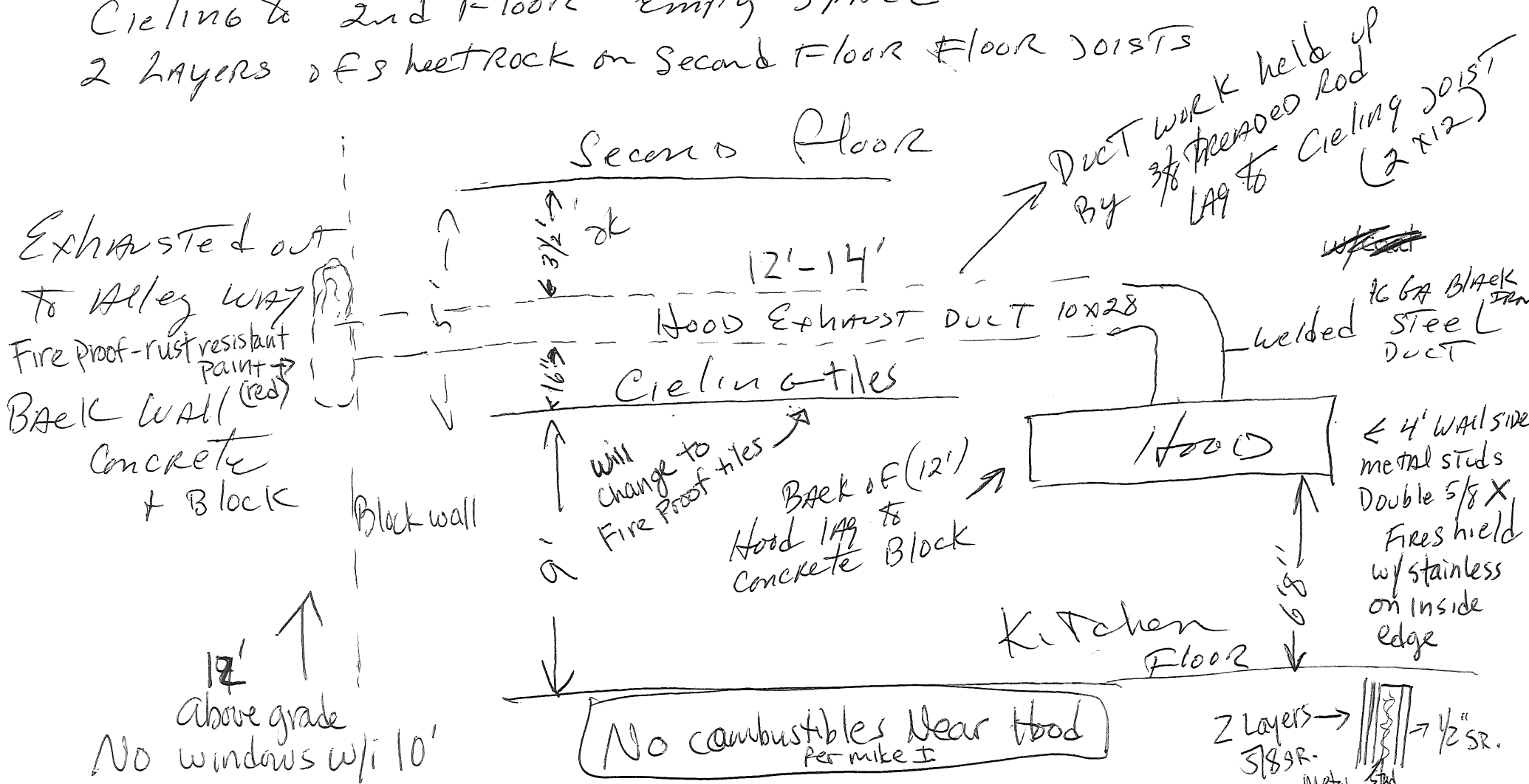

Hood hung with 6-1/2" Threaded Rod 5/16 x 4 1/2" LAGS INTO Ceiling joist THAT ARE 2x12

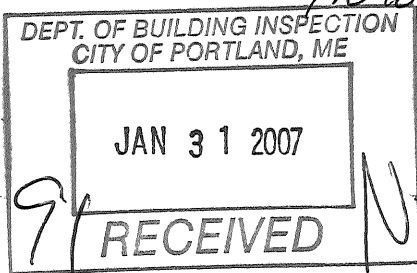

Mike - 615-2891 Notes per Mike Fosha 2/1/07

MIKE 615-2891²⁰⁷
NATIONAL AIR + SEA

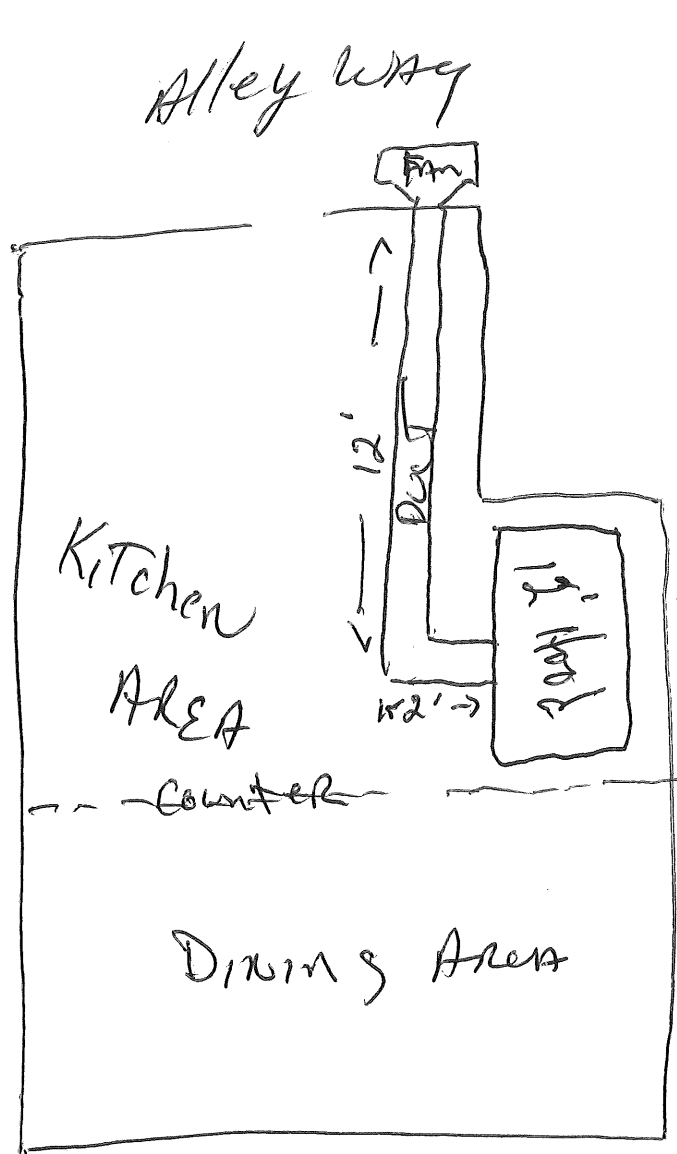

All Ducts Hung
on Threaded Rod

Hood Lagged to
non Combustible wall
Also 6 1/2" threaded Rod Hangers
off of Top of Hood

Rubys
127 Commercial St



PORTLAND MAINE

Strengthening a Remarkable City, Building a Community for Life • www.portlandmaine.gov

Lee Urban- Director of Planning and Development
Michael J. Nugent- Inspections Division Director

Kitchen Exhaust System Checklist and Code Provisions

Dear Applicant,

The following is a checklist to assist you in filing for a permit for a Kitchen Exhaust system. The applicable Mechanical Code provisions have also been attached. Please complete this and submit job specific construction documents that demonstrate compliance with the attached information.

Type of System:

Type I Type II

(Type I systems are systems that vent fryers, grills, broilers, ovens or woks. Type II systems are systems that vent steamers and other non grease producing appliances)

Type of Materials:

Is the hood Stainless steel or other type of steel? yes If Other, what Type? _____

Is the duct work Stainless steel or other type of steel? BLACK IRON If Other, what type? _____

Thickness of the steel for the hood 16 GA

Thickness of the duct for the hood 16 GA

Type of Hood and Duct supports 1/2" Threaded Rod

Type of seams and Joints all MIG welded

Grease Gutters provided? yes

Hood Clearance from Combustibles materials _____

Duct Clearance from Combustibles materials 12"

Vibration Isolation System:

Air Velocity within the duct system 3000 CFM

Grease accumulation prevention system

Cleanouts 1

Grease Duct enclosure _____

Exhaust Termination OUTSIDE wall

Fire Suppression system Done by others

Exhaust fan mounting and clearance from the roof or wall
Factory supplied wall kit

Exhaust fan distance from other vents or openings 2' FROM Kitchen Exhaust
ALREADY EXISTING

Exhaust fan height above adjoining grade _____

Hood Specs

Style of hood CAPITIVE AIR PSP-F

Type of Filter: STAINLESS STEEL Baffle

Height of filter above nearest cooking surface: _____

Capacity of hood in CFM 3000

Make up Air system description and capacity
90° MAKE-UP AIR
model NSAU-1

THE HOOD MAY BE INSTALLED WITH A 0 INCH CLEARANCE TO COMBUSTIBLE MATERIALS IF CONSTRUCTED IN ONE OF THE FOLLOWING METHODS:

- 3" UNINSULATED STANDOFF
- 1" INSULATED STANDOFF
- 1" INSULATED BACKSPASH
- BACK RETURN SUPPLY PLENUM

TABLE 1

ETL LISTING DESCRIPTION
THE CAPTIVE AIRE MODEL

ND-2 HAS BEEN E.T.L. TESTED, LISTED, AND APPROVED TO EXHAUST A MINIMUM OF 200 CFM PER LINEAR FOOT OVER 600 DEGREE COOKING EQUIPMENT

1. ALL ELECTRICAL "FIELD" CONNECTIONS AND RELATED INTERCONNECTIONS BY ELECTRICAL CONTRACTORS.
2. ALL PLUMBING "FIELD" CONNECTIONS AND RELATED INTERCONNECTIONS BY PLUMBING CONTRACTORS.
3. ALL ASSOCIATED HANGER MATERIALS BY INSTALLING CONTRACTORS.
4. 8" LONG FACTORY LOCATED AND WELDED HANGER BRACKETS AS SHOWN ON PLANS.
5. ALL CONNECTIONS FROM CAPTIVE-AIRE DUCT PER THE PLANS BY MECHANICAL CONTRACTORS.
6. ALL LIGHTS SHOWN INSTALLED BY CAPTIVE-AIRE, ARE FACTORY PREWIRED PER THE PLANS, INTERCONNECTIONS BETWEEN HOODS AND TO SWITCHES BY ELECTRICAL CONTRACTOR.
7. LAMPS FOR LIGHT FIXTURES BY INSTALLING CONTRACTORS.
8. SEISMIC RESTRAINTS ARE RESPONSIBILITY OF INSTALLING CONTRACTOR.
9. INSTALLING CONTRACTORS ASSUME ALL RELATED RESPONSIBILITY FOR VERIFICATION OF DIMENSIONAL DATA CONTAINED ON THESE DOCUMENTS FOR ACCURACY, INTEGRATION, AND ADMINISTRATION OF CODE REQUIREMENTS IN EFFECT PRIOR TO ANY RELEASE FOR PRODUCTION OF EQUIPMENT SHOWN.
10. SIGNED AND "APPROVED" COPIES OF THIS DOCUMENT MUST BE RECEIVED BY THE FACTORY PRIOR TO COMMENCEMENT OF FABRICATION.
11. NOMINAL HOOD DIMENSIONS AS SHOWN ON DRAWINGS.

GENERAL NOTES

IT IS THE RESPONSIBILITY OF THE ARCHITECT/OWNER TO ENSURE THAT THE HOOD CLEARANCE FROM LIMITED-COMBUSTIBLE AND COMBUSTIBLE MATERIALS IS IN COMPLIANCE WITH LOCAL CODE REQUIREMENTS

1/2" DIA. ALL THREAD ROD CONNECTED TO ROOF JOIST THROUGH ANOTHER HANGING ANGLE
1/2" DIA. HEAVY DUTY NUT ONE ABOVE AND ONE BELOW HANGING ANGLE

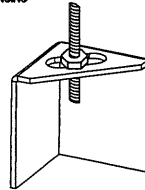

*ROD AND NUTS TO BE SUPPLIED BY INSTALLING CONTRACTOR HANGING ANGLE IS PRE-PUNCHED AT FACTORY

ND-2 HANGING ANGLE DETAIL

$$\begin{aligned} \text{EXHAUST CFM} &= \text{LENGTH OF HOOD} \times \text{CFM/LIN.FT. (LOAD)} \\ \text{SUPPLY CFM} &= \text{EXHAUST CFM} \times \text{PERCENTAGE REQUIRED} \\ \text{TOTAL DUCT AREA} &= 144 \times \frac{\text{CFM}}{\text{FMP}(\ast)} \\ \text{DUCT LENGTH} &= \frac{\text{TOTAL DUCT AREA}}{\text{DUCT DEPTH}} \end{aligned}$$

*CAPTIVE-AIRE VENTILATOR DUCT SIZES ARE CALCULATED USING AN EXHAUST VELOCITY OF 1800-1800 FPM AND A SUPPLY VELOCITY OF 1000 FPM. PLEASE CONSULT FACTORY FOR MAXIMUM ALLOWABLE DUCT SIZES

CALCULATIONS UTILIZED

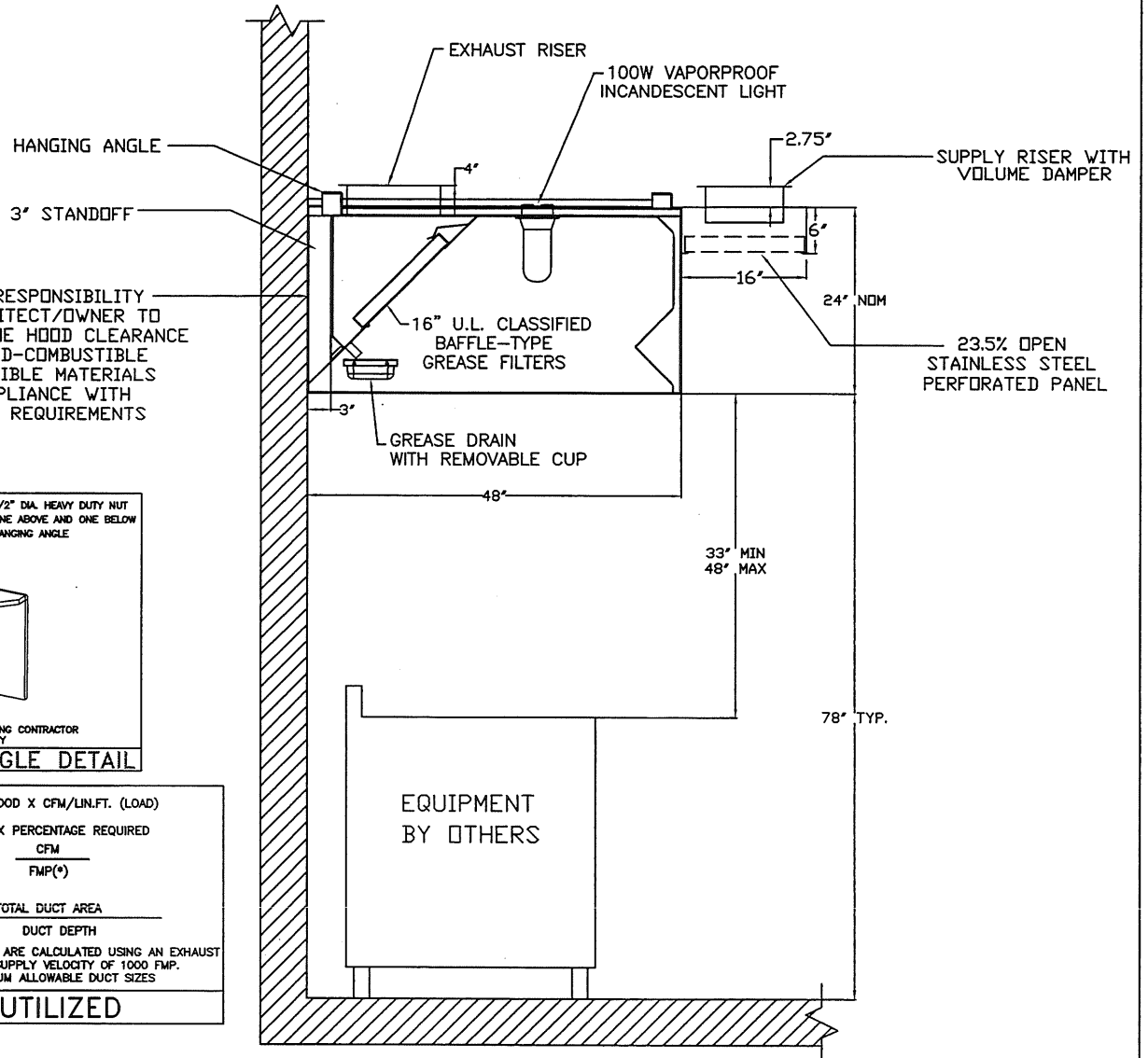

SECTION VIEW - MODEL 4824-ND-2 with PSP Accessory

CUSTOMER APPROVAL TO MANUFACTURE:

Approved as Noted

Approved with NO Exception Taken

Revise and Resubmit

SIGNATURE _____

Your Title _____ Date _____



JOB Ruby's	
LOCATION	
DATE 12/22/2006	JOB # 534369
DWG # Ruby's	DRAWN BY BFC
REV. 1.00	SCALE 8.5" x 11"

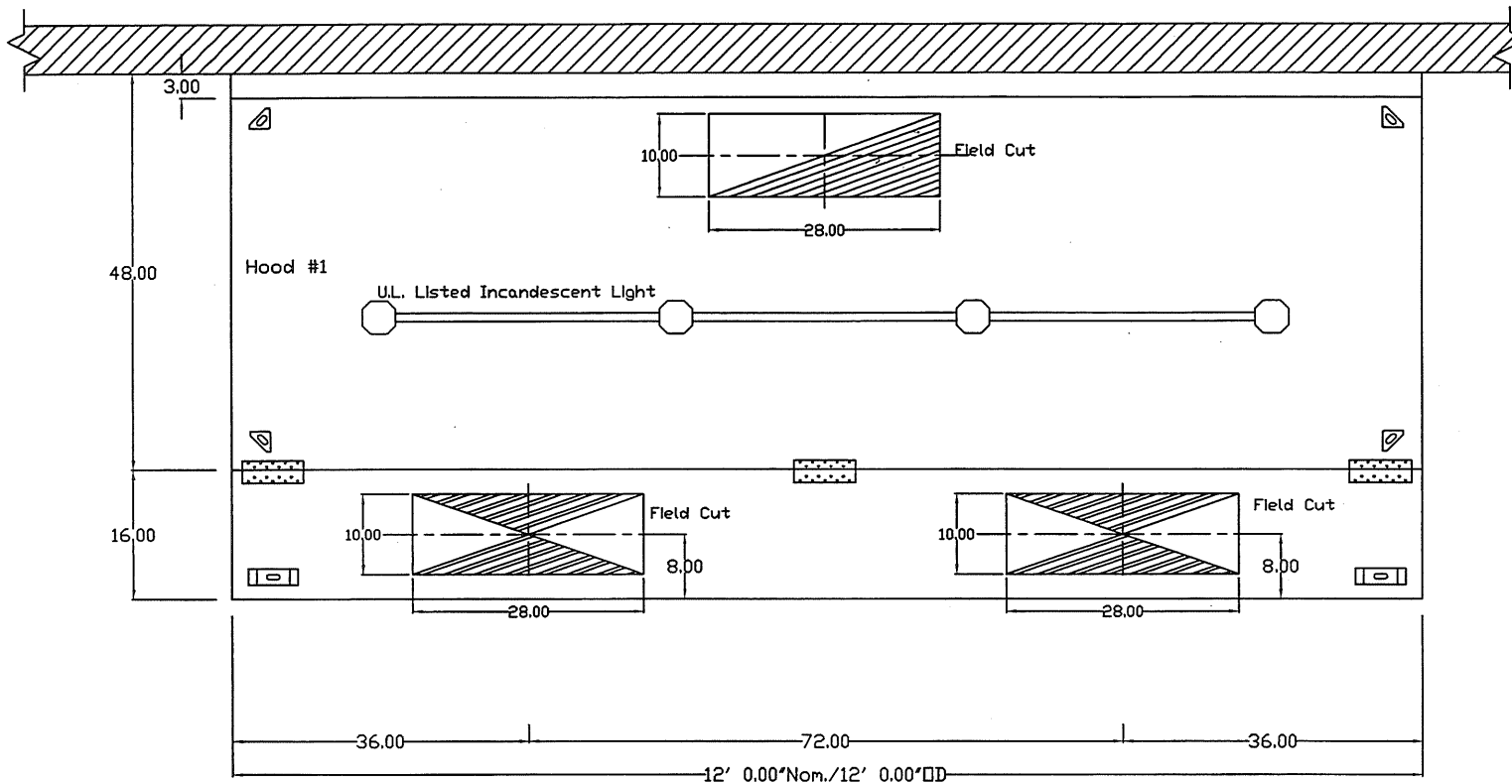

PLAN VIEW - 12' 0.00" LONG 4824ND-2-PSP-F

CUSTOMER APPROVAL TO MANUFACTURE:

- Approved as Noted
- Approved with NO Exception Taken
- Revise and Resubmit

SIGNATURE _____

Your Title _____ Date _____



JOB Ruby's	
LOCATION	
DATE 12/22/2006	JOB # 534369
DWG # Ruby's	DRAWN BY BFC
REV. 1.00	SCALE 8.5" x 11"

FAN INFORMATION

FAN UNIT NO.	FAN UNIT MODEL #	EXHAUST FAN										SUPPLY FAN									
		MODEL	TAG	CFM	S.P.	RPM	H.P.	Ø	VOLT	FLA	BLOWER	HOUSING	TAG	CFM	S.P.	RPM	H.P.	Ø	VOLT	FLA	
1	NCA16FA	NCA16FA		3000	0.750	1007	1.000	1	115	14.0											
2	NSAU1-G10										G10	NSAU.1		2100	0.250	728	0.750	1	115	12.0	

FAN OPTIONS

FAN NO.	OPTION (Qty. - Descr.)
1	1 - Grease Box
	1 - Wallmount 27.5 sq. x 2'
2	1 - Gravity Backdraft Damper for Size 1 Housing
	1 - Wall Mount Option for Size 1 Untempered Fan

FAN ACCESSORIES

FAN UNIT NO.	FAN UNIT TAG	EXHAUST			SUPPLY			
		GREASE CUP	GRAVITY DAMPER	WALL MOUNT	SIDE DISCHARGE	GRAVITY DAMPER	MOTORIZED DAMPER	WALL MOUNT
1		YES		YES				
2					YES	YES		YES

CUSTOMER APPROVAL TO MANUFACTURE:

Approved as Noted

Approved with NO Exception Taken

Revise and Resubmit

SIGNATURE _____

Your Title _____ Date _____



JOB Ruby's

LOCATION

DATE 12/22/2006

JOB # 534369

DWG # Ruby's

DRAWN BY BFC

REV. 1.00

SCALE 8.5" x 11"

NCAFA SERIES UPBLAST EXHAUST FANS (UL762)

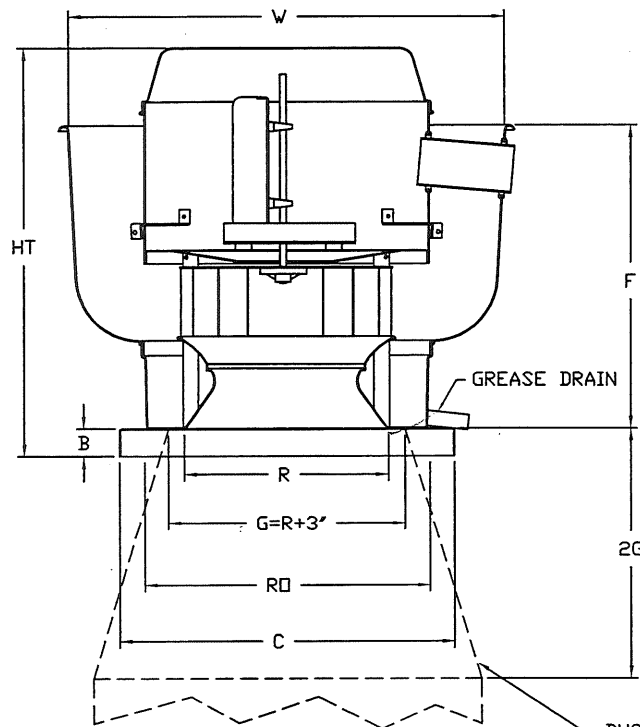

FEATURES:

- ROOF MOUNTED FANS
- RESTAURANT MODEL
- UL762
- AMCA SOUND AND AIR CERTIFIED
- WIRING FROM MOTOR TO DISCONNECT SWITCH
- WEATHERPROOF DISCONNECT
- HIGH HEAT OPERATION 300°F (149°C)
- GREASE CLASSIFICATION TESTING

NORMAL TEMPERATURE TEST

EXHAUST FAN MUST OPERATE CONTINUOUSLY WHILE EXHAUSTING AIR AT 300°F (149°C) UNTIL ALL FAN PARTS HAVE REACHED THERMAL EQUILIBRIUM, AND WITHOUT ANY DETERIORATING EFFECTS TO THE FAN WHICH WOULD CAUSE UNSAFE OPERATION.

ABNORMAL FLARE-UP TEST

EXHAUST FAN MUST OPERATE CONTINUOUSLY WHILE EXHAUSTING BURNING GREASE VAPORS AT 600°F (316°C) FOR A PERIOD OF 15 MINUTES WITHOUT THE FAN BECOMING DAMAGED TO ANY EXTENT THAT COULD CAUSE AN UNSAFE CONDITION.

OPTIONS:

- GREASE BOX

NCAFA BELT DRIVE
CENTRIFUGAL UP-BLAST EXHAUST FANS DIMENSIONAL DATA

DUCTWORK BETWEEN
EXHAUST RISER ON HOOD
AND FAN (BY OTHERS)

FAN MODEL	HT	W	B	C	F	R	RD	WEIGHT LB
NCA16FA	33 3/4	38	2	28	23 1/2	16 1/2	24 1/2	190

CUSTOMER APPROVAL TO MANUFACTURE:

Approved as Noted

Approved with NO Exception Taken

Revise and Resubmit

SIGNATURE _____

Your Title _____ Date _____



JOB Ruby's	
LOCATION	
DATE 12/22/2006	JOB # 534369
DWG # Ruby's	DRAWN BY BFC
REV. 1.00	SCALE 8.5" x 11"

WALL MOUNT BRACKET

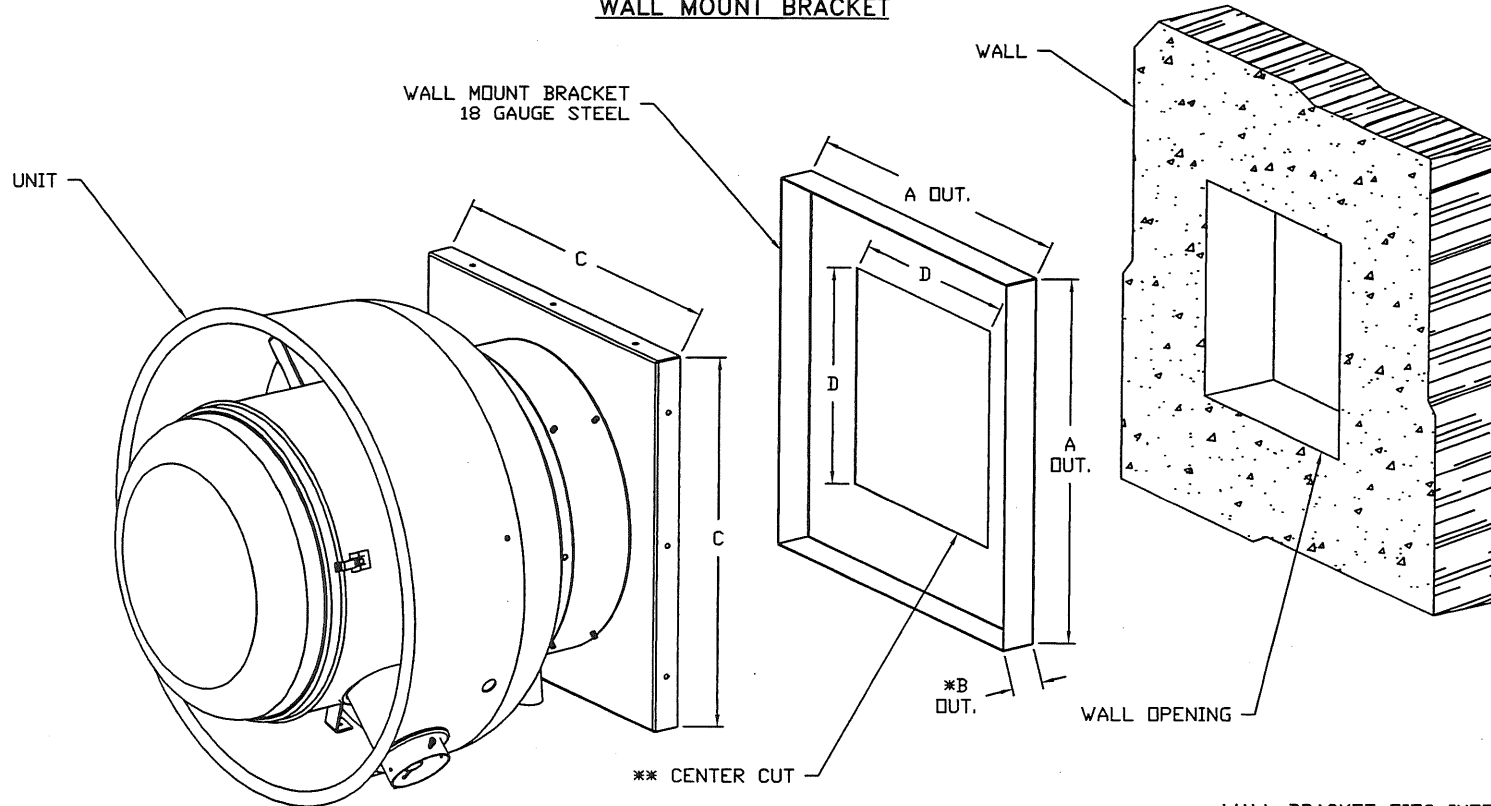

** CENTER CUT

A OUT.	B OUT.	C	D
18 1/2	2	19	13
20 1/2	2	21	16
21 1/2	2	22	16
24 1/4	2	24 3/4	20
25 1/2	2	26	20
→ 27 1/2	2	28	24
32 1/2	2	33	28

WALL BRACKET FITS INTO BASE OF FAN

SELF DRILLING SCREWS SHOULD BE USED
FOR UNIT ATTACHMENT TO WALL MOUNT BRACKET

* 'B' DIMENSION = 5' WHEN USED WITH DAMPER
** CENTERED IN WALL MOUNT

CUSTOMER APPROVAL TO MANUFACTURE:

Approved as Noted

Approved with NO Exception Taken

Revise and Resubmit

SIGNATURE _____

Your Title _____ Date _____

CAPTIVE AIR

JOB Ruby's

LOCATION

DATE 12/22/2006

JOB # 534369

DWG # Ruby's

DRAWN BY BFC

REV. 1.00

SCALE 8.5" x 11"

NSAU-1 AND NSAU-2 SERIES SIDE DISCHARGE SUPPLY FANS



SUPPLY AIR UNIT DIMENSIONAL DATA

MODEL	BLOWER	HP RANGE	A	B	C	D	E	F	FILTER QTY.	FILTER SIZE	WEIGHT
NSAU-1	G-10	.33 - 2	26	32	28	20	20	26	2	16' X 20'	175 LBS
NSAU-2	G-12	.33 - 3	36	40	35	28.5	25	29	2	20' X 25'	275 LBS
	G-15	.75 - 5						53.75	3	20' X 25'	315 LBS

CURB/BLOWER DIMENSIONAL DATA

MODEL	BLOWER	G	H	J	K	L	M
NSAU-1	G-10	23	14	11-3/4	13-1/2	13	6-1/4
NSAU-2	G-12	32.5	14	13-3/4	15-7/8	18	10
	G-15			16-1/8	18-7/8	18	6-1/2

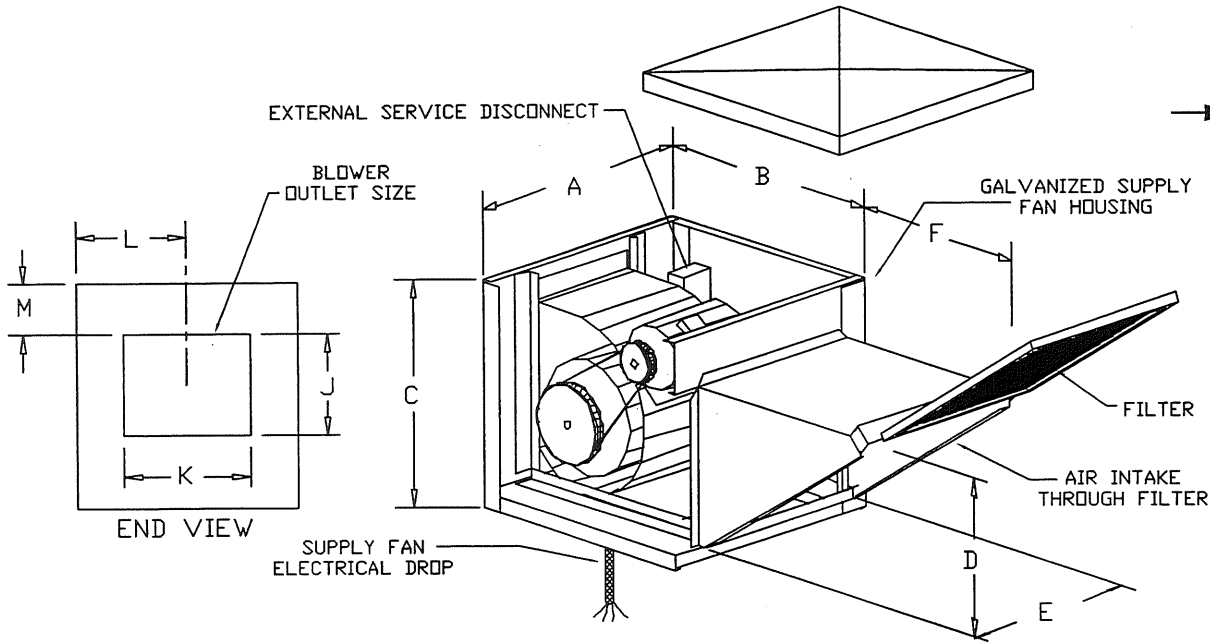

CAPTIVE-AIRE SYSTEMS, INC. RESERVES THE RIGHT TO MODIFY THE DESIGN, MATERIALS AND/OR SPECIFICATIONS AS A RESULT OF CODE REQUIREMENTS OR PRODUCT ENHANCEMENTS RESULTING FROM ONGOING RESEARCH AND DEVELOPMENT.

CUSTOMER APPROVAL TO MANUFACTURE:

Approved as Noted

Approved with NO Exception Taken

Revise and Resubmit

SIGNATURE _____

Your Title _____ Date _____

CAPTIVE-AIRE

JOB Ruby's	
LOCATION	
DATE 12/22/2006	JOB # 534369
DWG # Ruby's	DRAWN BY BFC
REV. 1.00	SCALE 8.5" x 11"

Untempered Supply Fan Wall Mount Bracket Detail

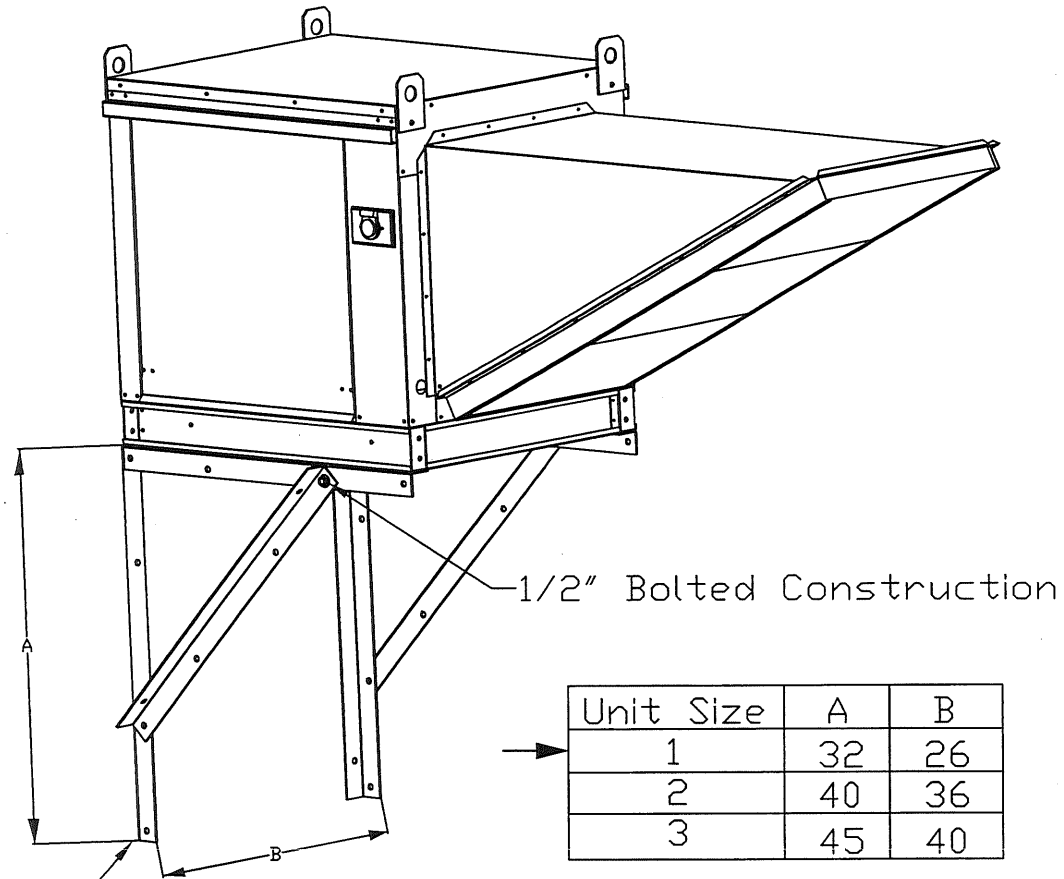

2" x 2" 10 GA Galv Angle

Unit Size	A	B
1	32	26
2	40	36
3	45	40

CUSTOMER APPROVAL TO MANUFACTURE:

Approved as Noted

Approved with NO Exception Taken

Revise and Resubmit

SIGNATURE _____

Your Title _____ Date _____

CAPTIVE AIRE

JOB Ruby's

LOCATION

DATE 12/22/2006

JOB # 534369

DWG # Ruby's

DRAWN BY BFC

REV. 1.00

SCALE 8.5" x 11"

ELECTRICAL PACKAGES

NO.	TAG	PACKAGE #	LOCATION	SWITCHES		ROOFTOP STARTERS	OPTION	FANS CONTROLLED				
				LOCATION	QUANTITY			TYPE	Ø	H.P.	VOLT.	FLA
1		11111002	Wall Mount In SS Box	SS Wall Mount Box	1 Light 1 Fan		Exhaust In Fire	Exhaust	1	1.000	115	14.0
								Supply	1	0.750	115	12.0

DETAIL OF REMOTE S/S BOX

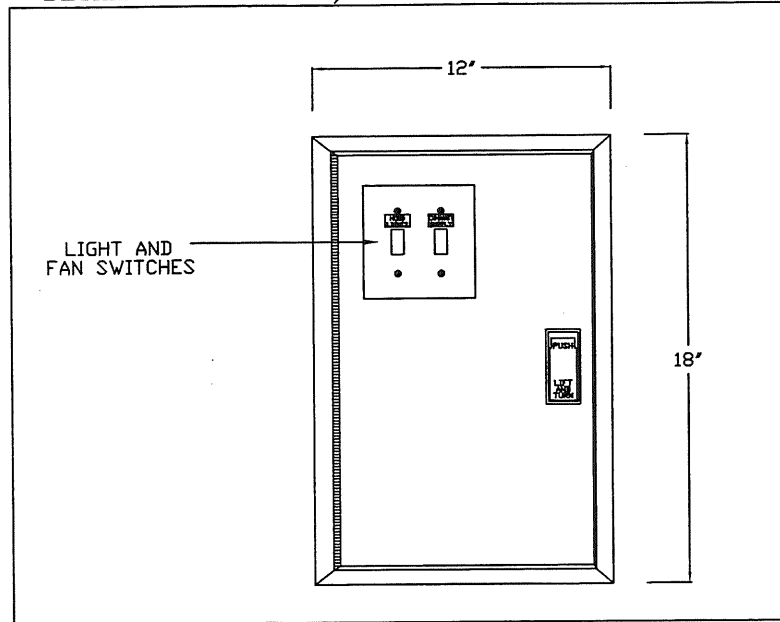

CUSTOMER APPROVAL TO MANUFACTURE:

Approved as Noted

Approved with NO Exception Taken

Revise and Resubmit

SIGNATURE _____

Your

Date _____

CAPTIVE AIRE

JOB Ruby's	
LOCATION	
DATE 12/22/2006	JOB # 534369
DWG # Ruby's	DRAWN BY BFC
REV. 1.00	SCALE 8.5" x 11"

ELECTRICAL PREWIRE PACKAGE

JOB NAME

DATE

DRAWING NUMBER 11111002

JOB NUMBER

DRAWN BY

CONTROL INPUT 120VAC H1=LINE, N1=NEUTRAL 15A BKR

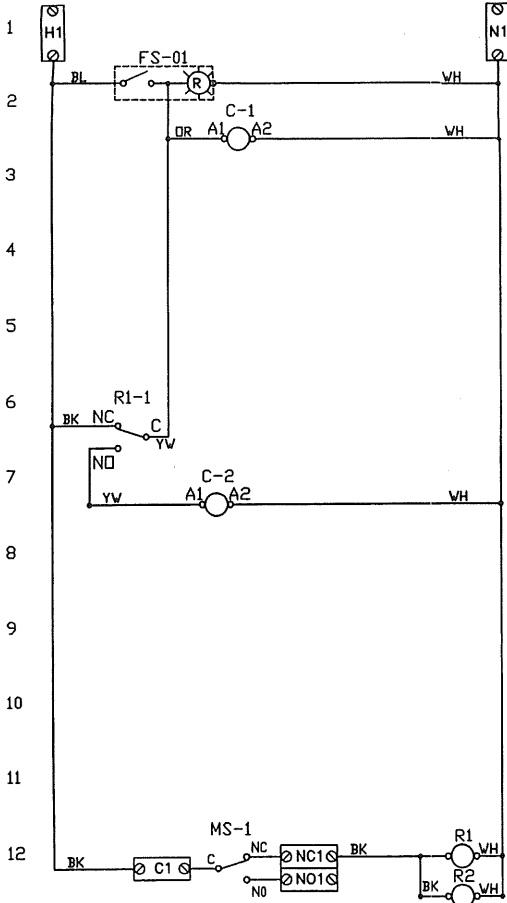

Electrical Package Description

120V/1Ph, W/ 1 Exhaust Fan, 1 Supply Fan, Exhaust in Fire

Component Identification

Label	Description
ST	Starter
FS	Fan Switch (Lighted)
MS	MicroSwitch (Ansul or PyroChem)
R1	Relay DPDT
LS	Light Switch
L	Hood Light(s)
GP	General Purpose Relay DPDT
TX	Transformer
C	Contactor
G	Ground
AF	Air Flow Switch

Spare Relay Contacts	MS-1, MS-2 MicroSwitch	
	Ansul	Pyrochem
C-RD	C-RD	C-RD
NO-BL	NO-BK	NO-BK
NC-PR	NC-BR	NC-BR

1	NC	3
4	NO	6
7	COM	9
A	COIL	B

SPARE RELAY CONTACTS CAN BE USED TO CONTROL ITEMS REQUIRING SHUT DOWN WHEN THE FIRE SYSTEM DISCHARGES, SUCH AS SHUNT TRIP, SIGNALS, ETC..

R1-R5 RELAY TERMINATIONS

Spare Relay Contacts

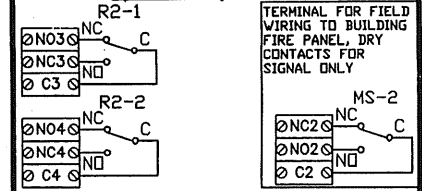

LIGHT INPUT 120VAC H2-H5=LINE, N2-N5=NEUTRAL 15A BKR

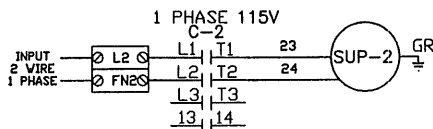
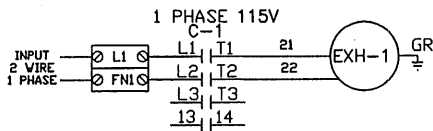
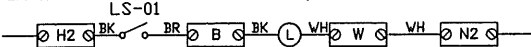

Motor	Type	PH	Volt	HP	FLA	BREAKER
Exh-1	Exh	1	115			
Sup-2	Sup	1	115			

NOTES

----- DENOTES FIELD WIRING
 _____ DENOTES INTERNAL WIRING

WIRE COLOR

BK - BLACK
 BL - BLUE
 BR - BROWN
 DR - DRANGE
 RD - RED
 WH - WHITE
 YW - YELLOW
 GY - GRAY
 PR - PURPLE
 DR/BL - DRANGE/BLUE (STRIPE)
 BL/RD - BLUE/RED (STRIPE)
 RD/GN - RED/GREEN (STRIPE)

DRAWING SHOWN DE-ENERGIZED

NOTE: IF WALL MOUNT PREWIRE, OR FIELD INSTALLED FIRE SYSTEM MICROSWITCH, THE TERMINALS SHOWING FACTORY WIRING MUST BE FIELD WIRED.

12 x 18 x 6 Box Size

HOOD INFORMATION

HOOD NO.	MODEL	LENGTH	MAX. COOKING TEMP.	EXHAUST PLENUM					SUPPLY PLENUM					HOOD CONSTRUCTION	HOOD CONFIG.		
				TOTAL EXH. CFM	RISER(S)				TOTAL SUP. CFM	RISER(S)					END TO END	ROW	
					WIDTH	LENG.	DIA.	CFM		S.P.	WIDTH	LENG.	DIA.				CFM
1	4824 ND-2-PSP-F	12' 0.00"Nom. 12' 0.00"DD	600 Deg.	3000	10"	28"		3000	-0.561"	2100					430 SS Where Exposed	ALONE	N/A

HOOD INFORMATION

HOOD NO.	FILTER(S)				LIGHT(S)			UTILITY CABINET(S)						FIRE SYSTEM PIPING	HOOD WEIGHT	
	TYPE	QTY.	HEIGHT	LENGTH	QTY.	TYPE	WIRE GUARD	LOCATION	FIRE SYSTEM		ELECTRICAL	SWITCHES				
									TYPE	SIZE	MODEL #	QUANTITY	LOCATION			
1	Alum. Baffle w/ Handle	4	16"	16'	4	Incandescent Light	NO								NO	424 LBS.

PERFORATED SUPPLY PLENUM(S)

HOOD NO.	POS.	LENGTH	WIDTH	HEIGHT	RISER(S)				
					WIDTH	LENG.	DIA.	CFM	S.P.
1	Front	144"	16'	6'	10"	28"		1050	0.133'
					10"	28"		1050	0.133'

CAPTIVE-AIRE HOODS ARE BUILT IN COMPLIANCE WITH



NFPA #96

NSF

UL 710 & ULC710 STANDARDS

E.T.L. LISTED 3054804-001

CUSTOMER APPROVAL TO MANUFACTURE:

Approved as Noted

Approved with NO Exception Taken

Revise and Resubmit

SIGNATURE _____

Your Title _____ Date _____



JOB Ruby's	
LOCATION	
DATE 12/22/2006	JOB # 534369
DWG # Ruby's	DRAWN BY BFC
REV. 1.00	SCALE 8.5" x 11"