



the power of possibilities™

NICHIHA ARCHITECTURAL WALL PANELS
INSTALLATION GUIDE
AWP-1818

NICHIHA ARCHITECTURAL WALL PANELS
INSTALLATION GUIDE
AWP-1818

TABLE OF CONTENTS

<i>Basics</i>	3
Limitations, Technical Reviews, Special Applications	4
Safety	4
Framing & Sheathing	5
Continuous Insulation	6
Weather Resistive Barriers	6
Storage & Handling	6
Fasteners	7
<i>Hardware & Accessories</i>	8
<i>Planning & Layout</i>	10
<i>Installing the Starter Track</i>	11
<i>General Panel & Accessory Basics</i>	12
Panel Selection	12
Sealing Cut Panel Edges	12
Cutting Ultimate Clips	13
Finish Clip Usage	14
Sealant	15
Sealant Joints/Caulking	15
<i>Panel Installation</i>	16
Structural Insulating Panels	18
Pre-Engineered Metal Buildings	18
<i>Inside Corners, Windows, & Doors</i>	19
Inside Corners	19
Window Sills	20
Window/Door Jambs	21
Window/Door Headers	22
Outside Corners	22
<i>Vertical Control/Expansion Joints</i>	25
<i>Horizontal/Compression Joints</i>	26
<i>Garage Doors & Other Openings</i>	27
<i>Penetrations, Railings, & Signage</i>	27
<i>Last Course</i>	28
<i>Gable & Overhang</i>	28
<i>Sloped Grade/Panels Below</i>	29
<i>Cleaning Panels</i>	30
<i>Paint Touch-Up</i>	30
<i>Removal of Exterior Acrylic Latex Paint</i>	30
<i>Other Paint & Graffiti Removal</i>	31
<i>Repairing Minor Damage</i>	31
<i>Panel Replacement</i>	32

GENERAL

This guide is intended to provide the key information needed to successfully install Nichiha's 1818mm Architectural Wall Panels (AWP-1818). Further installation information and technical resources such as animated instructional videos, Technical Bulletins, three-part specifications, product testing and certifications, architectural details in AutoCAD, Revit, and PDF versions, and other technical documents are available on our website: Nichiha.com/resources.

Install products in accordance with the latest installation guidelines and all applicable building codes and other laws, rules, regulations and ordinances. Review all installation instructions and other applicable product documents before installation.

PRODUCT INSPECTION

Inspect all products thoroughly prior to installation. Do not install any product which may have been damaged in shipment or appears to have a damaged or irregular finish. Should you have a question or problem with your order, contact your local dealer or Nichiha Customer Service, toll-free, at 1.866.424.4421. *Keep the products dry prior to installation. It is best to store the products indoors.*

BASICS OF THE AWP-1818 SYSTEM

Nichiha AWP-1818 dimensions are 455mm (h) x 1,818 (l) x 16, 18, or 21mm(t). It is important to keep in mind the actual metric dimensions when considering panel layout, placement of control and compression joints, and with respect to sizing window and door openings. Imperial equivalent dimensions of AWP-1818 are 17-7/8 inches (h) x 71-9/16 inches (l) x 5/8, 3/4 or 7/8 inch (t).

(Fig. 1)

Panel edges are shiplapped and a factory sealant gasket is included on the top and right edges of AWP-1818. When the panels fit together, all factory joints are sealed. AWP attachment hardware engages the top and bottom panel edges, holding the panels off the substrate surface by 10mm (~3/8") and creating a closed-joint, drained/back-ventilated rainscreen system with concealed fastening. When accounting for the overall thickness of the AWP system, add this 10mm plus the thickness of the panel (16, 18, or 21mm) for a total system thickness of 26, 28, or 31mm.

AWP-1818 must only be installed horizontally.

Fig. 1

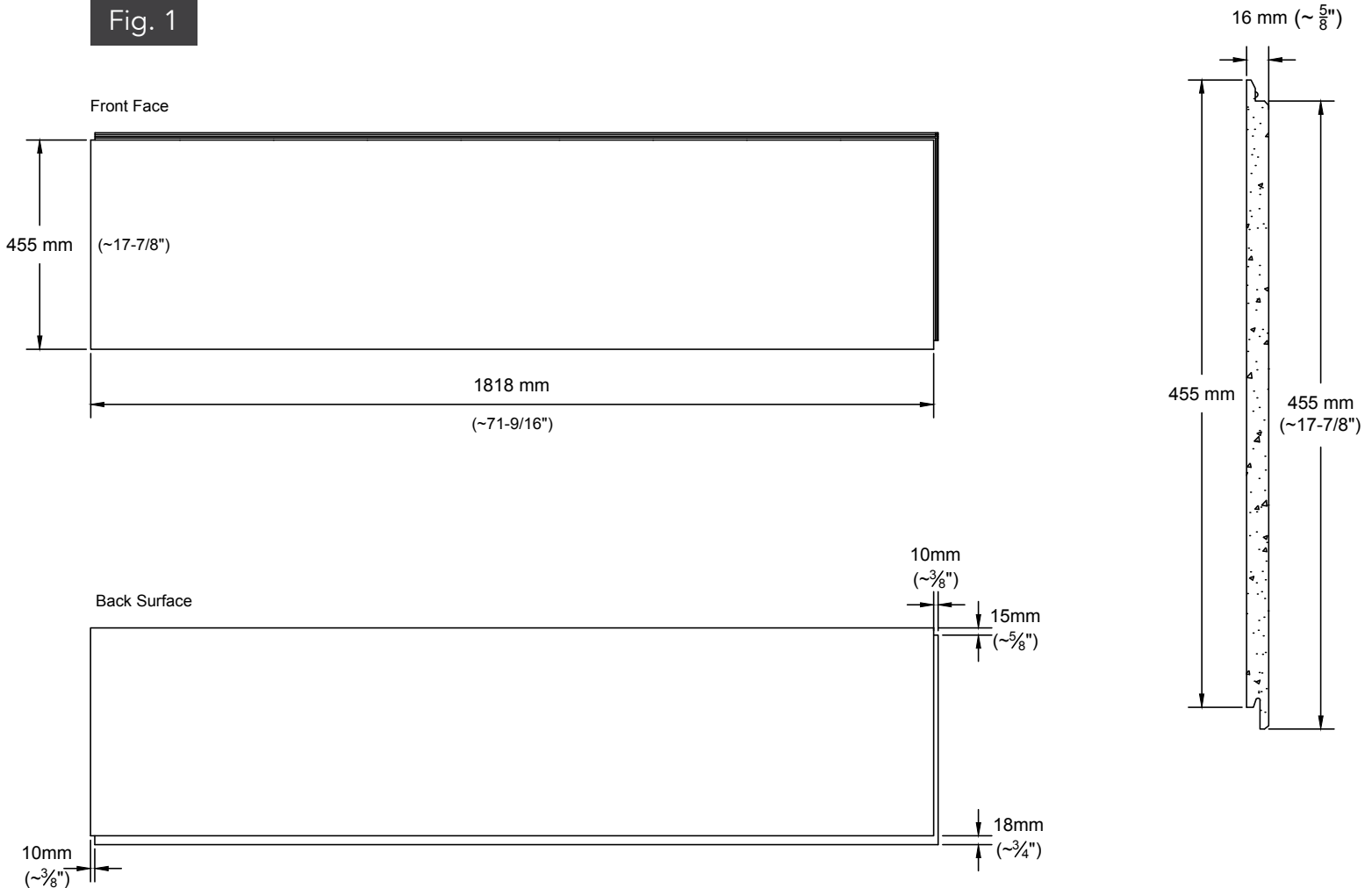

AWP-1818 GENERIC PANEL DETAIL
SCALE: 1" = 1'-0"

SCALE: 3" = 1'-0"

LIMITATIONS, TECHNICAL REVIEWS & SPECIAL APPLICATIONS

Natural limitations on product usage are inherent to any cladding product's design, physical characteristics, and attachment system. Nichiha AWP are intended as a low-to-mid-rise cladding product and are not for use on high-rise buildings.

Any project of more than three stories or 45 feet, as well as those located in high wind coastal areas (Exposure Categories C and D with Basic Wind Speed in excess of 130 mph), or those with any wall assembly not described in *Framing & Sheathing Requirements*, require a technical review by Nichiha to evaluate feasibility via our Technical Review and Special Application Form (SAF) process.

By evaluating a project's unique criteria and design, we can reference independently test-derived and calculated wind load performance data for our products to determine whether and how the panels can safely be installed on the project. Contact your local rep or Nichiha technical department for details or to initiate an SAF.

AWP are not to be used in any applications/uses not specified or described in this installation guide or other Nichiha technical documents. Any such use shall not be backed by the manufacturer's product warranty. Do not use AWP on open screen walls or Insulated Concrete Forms (ICFs). Installation of AWP products on modular structures that are factory-constructed and then transported to a final site are not approved; and further, excluded from the Limited Product Warranty, per Section 2.F. Please contact Nichiha Technical Services for assistance.

SAFETY

As with any natural stone, masonry, or concrete based product, when cutting, drilling, sawing, sanding, or abrading fiber cement cladding, proper safety measures must be taken due to the potential for airborne silica dust, an OSHA-identified hazardous substance that can pose serious medical risks.

Always wear safety glasses and a NIOSH/OSHA approved respirator with a rating of N, O, or P 100. Carefully follow the respirator manufacturer's instructions as well as applicable governmental safety regulations concerning silica. Refer to Nichiha's SDS for more information.

Always cut fiber cement panels outside and with a dust-collecting HEPA system. Do not cut the products in an enclosed area.

Use a dust-reducing circular saw with diamond-tipped or carbide-tipped fiber cement saw blades.

Always clean panels after cutting. Fiber cement dust can potentially bind to the panel finish.

FRAMING & SHEATHING REQUIREMENTS

Nichiha AWP cladding may be installed on vertical walls only. No tilted/sloped walls, soffits, or ceilings. Wood or steel framing, concrete/masonry with furring, Structural Insulating Panels (SIP), and pre-engineered metal buildings (PEMB) must meet the following requirements:

Prior to Nichiha installation, closely inspect exterior wall substrate and correct any problems. Walls that are out of plumb, for example, can negatively impact the installation quality of AWP. Nichiha Spacer may be used in conjunction with panel attachment hardware if necessary to ensure an even substrate.

Refer to PEI-PER 14088 for wind load data.

Wood Studs

Size: minimum 2x4 studs

Spacing: 16" o.c max

Sheathing: exterior grade minimum 7/16" plywood/OSB (APA rated), 1/2" or 5/8" gypsum

Metal Studs

Gauge: minimum 18

Spacing: 16" o.c max

Sheathing: exterior grade minimum 7/16" plywood/OSB (APA rated), 1/2" or 5/8" gypsum

Concrete/Masonry

Furring is required for installation of AWP over concrete and masonry structures.

Wood Furring: pressure treated lumber 2x4 or 5/4x4's, oriented vertically, spaced 16" o.c. max

Metal Furring: hat channel, c-stud, or z-furring, minimum 18 gauge with 1-2" flanges, oriented vertically, spaced 16" o.c. max

Structural Insulating Panels (SIP)

SIPs should be installed in accordance with manufacturer's instructions and local building codes. Additional special Nichiha installation requirements for SIPs are discussed in the *Fasteners* and *Installing the First Course* sections to follow. For installations greater than one story, contact Technical Department for assistance.

Pre-Engineered Metal Buildings (PEMB)

Metal buildings must be new construction. No retrofits/remodels.



Photo Credit: Nucor Building Systems

Metal siding/skin deflection limit of L/120.

50 ksi metal panels must have ribs spaced no more than 12" O.C. with metal gauge determined by allowable wind design pressures:

Metal Panel Gauge	Allowable Pressure
24 gauge	-31.41 psf
22 gauge	-39.29 psf

Projects with allowable design pressures in excess of the table values may not utilize AWP directly over PEMB metal panels.

Additional special installation requirements for PEMBs are discussed in the *Fasteners*, *Installing the Starter Track*, and *AWP-1818 Panel Installation* sections to follow.

CONTINUOUS INSULATION

Where exterior/continuous insulation is used, AWP may be installed directly over up to 1" of foam plastic insulation on wood or gypsum sheathing. Greater amounts require a structural solution to provide attachment points for AWP such as a furring grid or third-party specialized system. Mineral wool c.i. of any thickness requires a furring.

Refer to the Technical Bulletin: Continuous Insulation and AWP available at Nichiha.com/resources/technical-bulletins.

Please contact Nichiha technical department for further assistance.

WEATHER RESISTIVE BARRIERS

A weather resistive barrier (WRB) is required when installing Nichiha panels over stud walls and SIPs. For CMU/concrete assemblies, Nichiha defers to local code requirements. Use an approved WRB as defined by the 2015 IBC. Refer to local building codes. Fluid applied WRBs are acceptable.

A breathable WRB is highly recommended when installing Nichiha panels for residential applications.

A breathable WRB is required for all commercial applications.

All openings must have appropriate flashing to prevent moisture penetration.

Follow manufacturer's guidelines and all local building codes.

STORAGE AND HANDLING

AWP are a finished product and care must be taken to protect them against damage prior to and during installation. Panels must be stored flat and kept dry. Refer to storage information included on product pallets.

Ensure panels are completely dry before installing. Panels **MUST** be carried on edge. Do not carry or lift panels flat. Improper handling may cause cracking or panel damage.

Direct contact between the panels and the ground must be avoided at all times. It is necessary to keep panels clean during installation process.

The custom color finish of Illumination Series panels requires 30 days to fully cure and extra care must be taken to avoid damage to the paint during the installation process.

Cut the panels with the face down. **ALWAYS CLEAN PANELS WITH A CLEAN, SOFT, DRY CLOTH AFTER CUTTING. DUST CAN BIND TO THE FINISH.**

WHEN SIDEWALKS ARE POURED AFTER AWP INSTALLATION, TAKE STEPS TO COVER/PROTECT PANELS NEAR GRADE. CEMENT DRIED ON AWP CANNOT BE REMOVED.



FASTENERS ALL APPLICATIONS

Fasteners must be corrosion resistant.

Stainless steel or corrosion resistant screws such as hot-dipped zinc or ceramic coated are recommended. Comply with all local building codes for fastener requirements.

Number 10 - 16, pan-head screws (HD .365") were used as clip fasteners for AWP wind load testing. The minimum size for clip fasteners is #8.

Number 7 finish screws with a bugle or flat head (min. head diameter 0.255") are appropriate for *face fastening* locations. These must penetrate framing per the minimum requirements below. Refer to the *Last Course* section on page 28 for face fastening best practices.

WOOD STUDS

Fasteners must penetrate solid structure by a minimum of 1".

METAL STUDS

Screws must penetrate solid structure by a minimum of 1/2". Three threads are needed for effective grab.

CONCRETE/ MASONRY

Furring to Masonry: Fastener type, size, and spacing to be determined under direction of an engineer and in accordance with local building codes.

AWP to Furring: Screws must penetrate wood furring a minimum of 1" or steel by 1/2".

STRUCTURAL INSULATING PANELS (SIP)

One inch, full-thread, corrosion resistant wood screws must be used.

Fasten starter track every 16" max.

Double fastening per each Nichiha clip (minimum of 4 screws per JEL777/787 clip) is required as there are fewer or no studs to secure the system.

PRE-ENGINEERED METAL BUILDINGS (PEMB)

PEMB wind load/panel gauge table (see *Framing & Sheathing Requirements*) contingent upon use of #10-16 x 1" pan head, S/D screws.

Fasteners must be spaced at no more than 12" o.c. into metal panel ribs.

INSTALLATION HARDWARE & ACCESSORIES



ULTIMATE HORIZONTAL STARTER TRACK

Horizontal Starter Track serves as the foundational support for the AWP system while also providing faster and greater ease of installation.

Horizontal Panels (AWP-1818): Starter Track **FA 700**



ULTIMATE CLIP

Ultimate Clips sit on the panel shiplaps, securing AWP to the wall and distributing dead loads to the structure. Together, Ultimate Clips and Starter Track hold the back surface of the panels off the substrate to create a 10mm (3/8") rainscreen space.

JEL 777 Clip Compatible with 16mm (5/8") AWP

JEL 787 Clip Compatible with 18 & 21mm (3/4" & 7/8") AWP



Joint Tab Attachments are included with Ultimate Clips and must be secured within a clip at the bottom of each AWP-1818 vertical joint to support panel lateral stability. Fasteners are included for use with the Joint Attachments only.



FINISH CLIP (OPTIONAL)

The Finish Clip provides an alternative to face fastening of AWP at certain termination points where the panel shiplaps are removed. Install over 5mm Spacer. Refer to *Finish Clip Usage* section for general instructions.

JE 310 Finish Clip – Compatible with all AWP



CORRUGATED SPACER

At termination points where Panel Clips cannot be used, Nichiha Corrugated Spacer is required to maintain the rainscreen space and prevent panel deflection at face fastening locations such as window sills and headers.

FS 1005 Spacer - 5mm

FS 1010 Spacer – 10mm

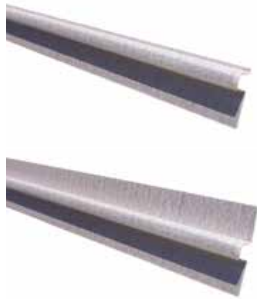

SEALANT BACKERS

Nichiha Sealant Backers provide exact spacing for expansion and termination joints and the recommended depth of sealant (75-80%). They provide faster installation than a foam backer rod and require less sealant. **At sealant joints, use a sealant that complies with ASTM C920, Class 35 (min.).** Refer to the *Sealant* section on page 15 for more information.

Single Flange Sealant Backer: FHK 1015 – 10 mm

Double Flange Sealant Backer: FH 1015 – 10 mm



NICHIHA CORNERS

Nichiha Corners are manufactured mitered panel corners available in the same finishes as all horizontally oriented AWP. Corners have 3-1/2" returns (face dimension).



METAL TRIM OPTIONS

Nichiha metal trim provides aesthetically pleasing design options for corners, openings, and transitions, as well as vertical joints.

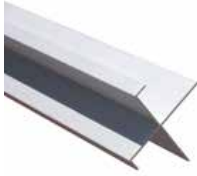

TRIM**	APPLICATIONS
Corner Key	Outside Corners
H-Mold	Vertical Joints
Open Outside Corner	Outside Corners
J-Mold	Terminations

**These trims are only compatible with 16mm thick panels.

ESSENTIAL FLASHING SYSTEM	APPLICATIONS
Starter*	Base/Clearance Concealment
Compression Joint	Horizontal/Compression Joints
Overhang*	Fascia-to-Soffit Transitions

*Inside and outside corner segments are available.

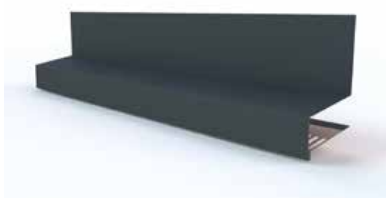

PLANNING & PANEL LAYOUT

To ensure a successful installation, it is important to first plan how the panels will be laid out, where compression and control joints will be located, and line of sight regarding inside corners decided.

Reminder: AWP-1818 actual dimensions are metric: 455mm (h) x 1,818mm (l). Imperial equivalents: 17-7/8" (h) x 71-9/16" (l).

Layout: AWP-1818 can be installed in a stacked bond or a staggered bond application. Refer to *Figures 36, 37* on Page 18.

Vertical Control/Expansion Joints

(Page 25): 10mm (3/8") sealant joints account for thermal expansion in the lateral dimension. These are often, where possible, aligned with window or door jambs, downspouts, or other features in order to minimize their appearance. *Depending on sheathing type, additional framing, furring, or blocking may be required.*

Horizontal/Compression Joints (Page 26): 1/2" (min.) horizontal, flashed break detail to allow for building compression at floor lines.

Inside Corner Line of Sight (Page 19): Sealant joints at inside corners can be placed out of view from the primary line of sight of a wall. Place the sealant joint on the less-viewed corner wall.

Cut Panels: In general, it is best to avoid cutting AWP to short or narrow strips and segments of less than 9". Specifically, when an individual panel is wider than a window or other opening and is used over the head or under the sill, do not cut it to less than 9" in height. (see image A)
When an opening is wider than an individual panel and two or more are needed to cap over the header or cup the sill, do not cut the panel to less than 4" in height. (see image B)

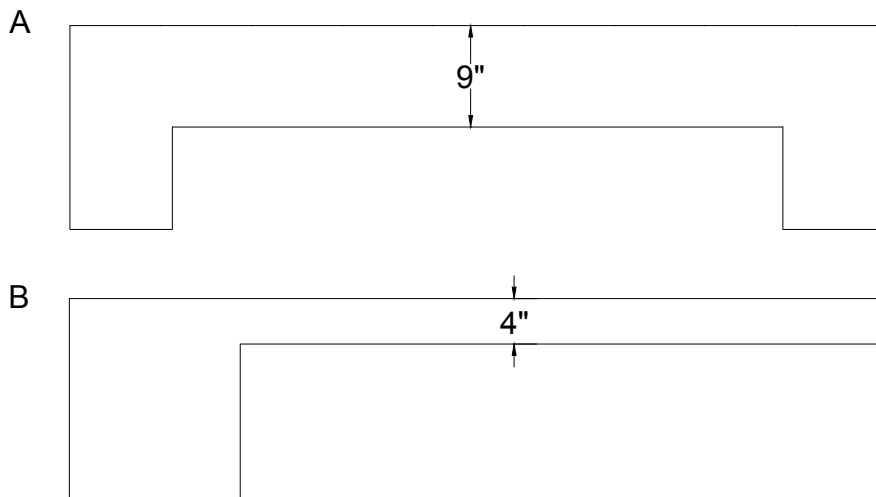

AWP-1818: INSTALLING THE HORIZONTAL ULTIMATE STARTER TRACK

ALL APPLICATIONS

The Horizontal Ultimate Starter Track must be level and attached at a minimum of 6" above finished soil grade or per local building codes (use a laser level to verify). When installing over a hard surface such as driveways or sidewalks, a 2" clearance is acceptable.

Essential Starter Flashing may be installed prior to the Starter Track to conceal the clearance gap above hardscape and decking. Beginning with outside and inside corner segments, fasten Flashing at each stud location or every 10" o.c. to sill plate. Fasten Flashing inside and outside corner segment to framing on both sides, keeping at least 1" from vertical edges. Main segments will slide into/overlap the corner segments. The AWP bottom face edge will extend 3/4" below the Starter Track. Position Flashing and/or Starter Track to leave 1/4" clearance between the panel edge and Flashing.



The Starter Track must be installed using corrosion resistant fasteners. Locate and mark the studs.

WOOD & METAL STUDS OR FURRING

Starter Track must be secured at every stud line.

CONCRETE/MASONRY

When installing over concrete construction, the wall must be furred out with pressure treated lumber or metal hat channel. Starter Track must be secured at each furring location.

STRUCTURAL INSULATING PANELS (SIP)

Secure Starter Track every 16" o.c. max.

PRE-ENGINEERED METAL BUILDINGS (PEMB)

Fasten Starter Track at every metal panel rib at 12" o.c. max.



Fig. 22

GENERAL PANEL & ACCESSORY BASICS

All trim, Single and Double Flange Sealant Backer should be installed before panels. Refer to *Inside Corners, Doors, & Windows* and *Vertical Expansion Joints* sections respectively.

PANEL SELECTION

Nichiha AWP-1818 are packaged with two panels in a pack, which are placed on pallets consisting of two stacks. Due to alternating patterns of texture and color between individual panels as well as how the panels are manufactured and packaged, it is best to install all panels from each individual stack before taking and installing panels from the second stack on the same pallet. Do not alternate installing from one stack and the second, which may result in undesirable patterns.

SEALING CUT PANEL EDGES

When cutting AWP, it is best to cut with the panel *face down*, except when cutting brick finish panels as it is easier to follow the simulated mortar lines on their face.

Cut and exposed panel edges must be primed or sealed with fiber cement sealer (e.g. DryLock®) or latex paint such as Kilz Premium® or Kilz Max®. Do not use Illumination touch up paint for edge sealing as there will not be sufficient supply for larger projects. **Be sure to clean panels with a clean, dry soft cloth after cutting to prevent dust from bonding to the finish.**

Fig. 23

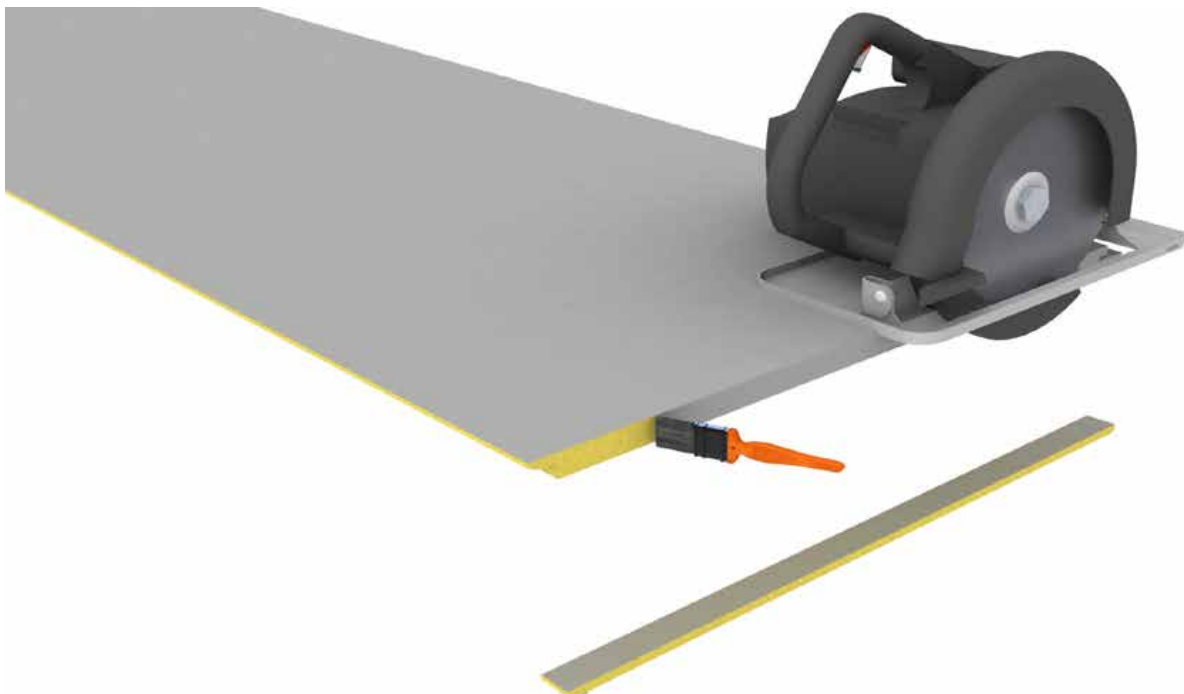

CUTTING ULTIMATE CLIPS

JEL777/787 Panel Clips are 26" long. Where full length clips can be used, they are required. However, there may be conditions where clips must be cut to accommodate panels or corner pieces in smaller areas or segments such as narrow columns, pilasters, or insets, recessed openings, or small areas between windows.

Notches on the upward panel engagement flanges indicate where clips can be cut evenly into thirds. These $\frac{1}{3}$ segments can be further reduced evenly into two or four pieces each with weep holes serving as dividing points. The smallest segment must include at least one downward panel engagement flange. Always use the widest clip segment possible.

Cut with a non-ferrous saw blade on a band or chop saw.

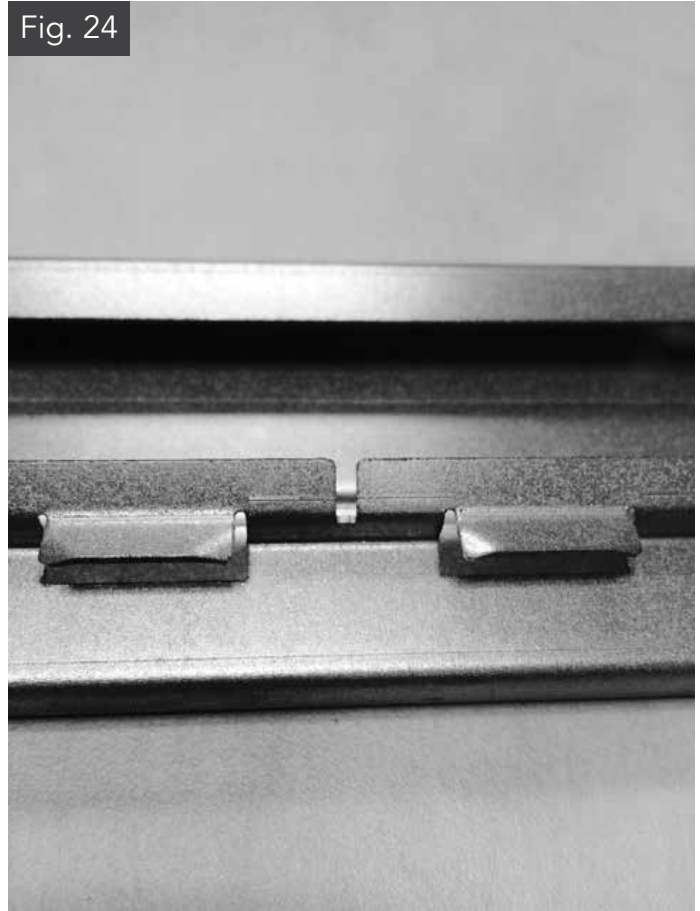
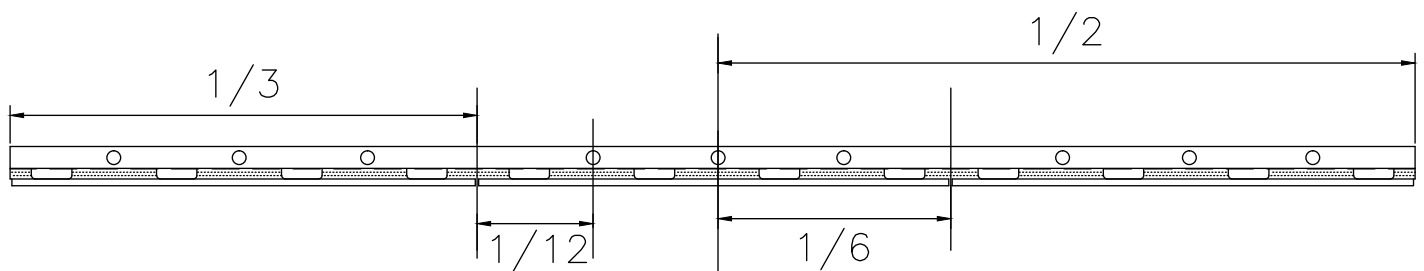

Fig. 25



FINISH CLIP USAGE

The Finish Clip requires added preparation of the panels with the use of a biscuit joiner:

1. To route grooves into the top edge of a panel, use a biscuit/plate joiner, such as Makita's PJ7000. A carbide blade is recommended.
2. Set the biscuit joiner's angle guide at zero degrees and height to $\frac{1}{4}$ ".
3. Set the depth of groove for a size 20 biscuit to ensure the grooves are wide and deep enough for JE310 clips to seat properly, $\frac{1}{4}$ " from the back/unfinished face of the panel.
4. Route the cut edge with the unfinished panel surface facing up, lining the grooves up with stud locations (16" o.c. maximum).
5. The clip should fit snug but not too tightly when placed on the panel. Cut, routed panel edges must be sealed with 100% acrylic latex primer or paint. Use 5mm Spacer with JE310 Finish Clips.



Fig. 26

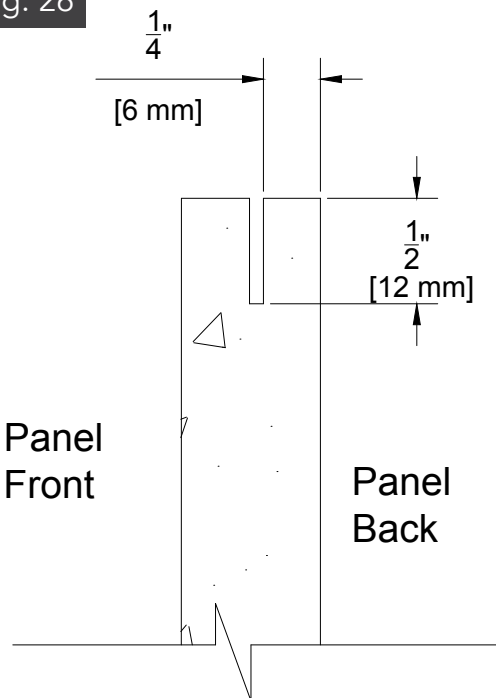

SEALANT

Sealants to be used with AWP must match the following requirements:

- Comply with ASTM C920
- Have a Class of 35, 50, or 100/50 (minimum 35% joint movement)
- Be a polyurethane, polyurethane hybrid, or Adfast Adseal 4580
- Provide two-sided adhesion at joints

OSI® QUAD® MAY NOT BE USED FOR NICHIIHA EXPANSION JOINTS

- It is a class 25 product.
- QUAD® MAX is acceptable since it is a Class 50.

Refer to the Technical Bulletin: Sealants available at Nichiha.com/resources/technical-bulletins.

SEALANT JOINTS/CAULKING

Fasten Single Flange Sealant Backers at inside corners (one wall at corner), along window and door jambs, and transition points with other cladding. Fasten to framing, blocking or plywood/OSB sheathing at 12-14" o.c. with the 3/8" bump/sealant portion butting the corner or jamb.

Sealant complying with ASTM C920, Class 35 (min.) is required where Single and/or Double Flange Sealant Backer is used.

Refer to the sealant manufacturer's instructions or requirements.

Fig. 30

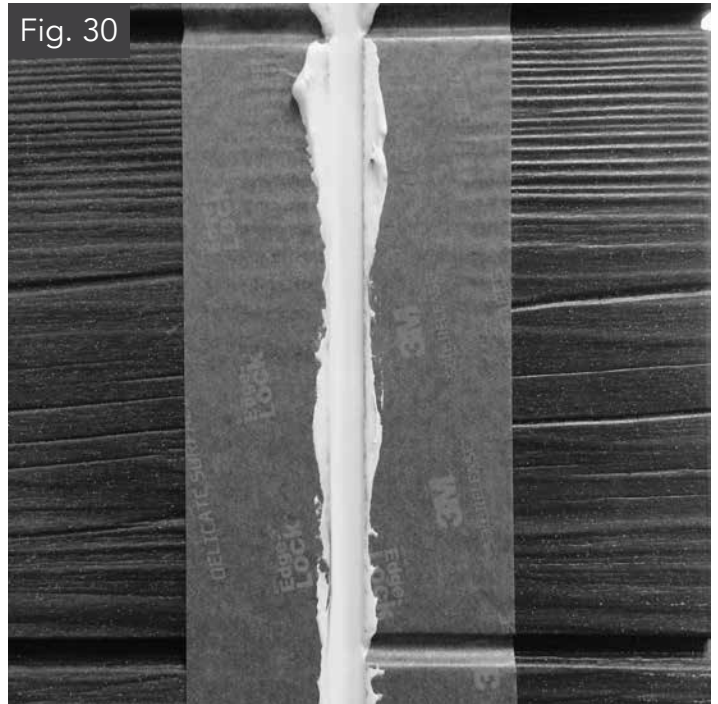

Place low-adhesive tape (masking or painter's) over the panel along the areas requiring sealant joints for a clean caulk line.

Fill the gap between the panels with a color-matched/coordinating sealant which complies with the ASTM C920, Class 35 (min.) standard. Nichiha Sealant Backers allow for the proper depth of sealant (75-80%).

Before removing tape, press the surface of the sealant with a caulk spatula or similar tool to ensure an even surface. Remove masking tape before sealant cures. If excess sealant adheres to panel, remove completely using a putty knife or soft cloth.

AWP-1818 PANEL INSTALLATION

AWP installation proceeds by working from left to right.

Wood, Metal, Concrete/Masonry with Furring

For AWP-1818, trim off the left side ship-lapped edge so the panel will fit tightly against an already installed inside corner spacer, Sealant Backer, or outside corner trim. If starting at an inside corner, predetermine which wall will include the Single Flange Sealant Backer for an inside corner detail. Consider the location to minimize the visibility of the sealant joint line. Clad the higher visibility wall without the sealant joint first so that the adjoining wall panels can terminate to it with the Single Flange Sealant Backer detail.

Set first panel into the Starter Track and secure the top edge with a Panel Clip, placing the first clip about one inch from the left edge of the panel. Fasten clip at each stud location the clip reaches. Every clip will cover 2-3 studs and must be fastened to each. *(Figure 31-32)*

Proceed along the panel to the right, placing another clip 3-4 inches from the end of the previously installed clip so that the second clip is roughly centered over the panel middle but DO NOT skip any studs. Fasten clip at each stud location.

Place the second panel next to the first, making sure the shiplap joint fits tightly together.

A rubber mallet or block of wood may be used to seat the panels firmly in place and tighten to the left. Do not hammer directly anywhere on the panels as direct contact may cause cracks, gouges, or chipping. *(Figure 33)*

Place a clip on top of this vertical joint. Vertical joints must be spanned with a clip covering the top edge of where the panels meet. Fasten clip to each stud it reaches, again not skipping any studs. Each long panel edge should be supported by about 2.5 clips. *(Figure 34)*

Verify the first course of panels is level. Large commercial buildings require checking level around the entire building.

Start the second row in the same fashion as the first, but, in addition to the previous steps, add the **Vertical Joint Tab Attachment** against the bottom right hand corner of each panel. The Attachment seats inside the panel clip, with tabs that fit on clip's rainscreen flange. Fasten the Attachment to the panel clip with the provided fastener. *(Figure 35)*

Fit panels tightly together on both horizontal and vertical joints, ensuring the panel edges are properly butted together.

Complete the second and remaining non-terminal rows in the same way, with the Vertical Joint Tab Attachments at the base of each vertical joint. Terminal rows such as under **Compression Joints** or at the **Last Course** are covered in subsequent sections of this guide.

Fig. 31



Fig. 32



Fig. 33

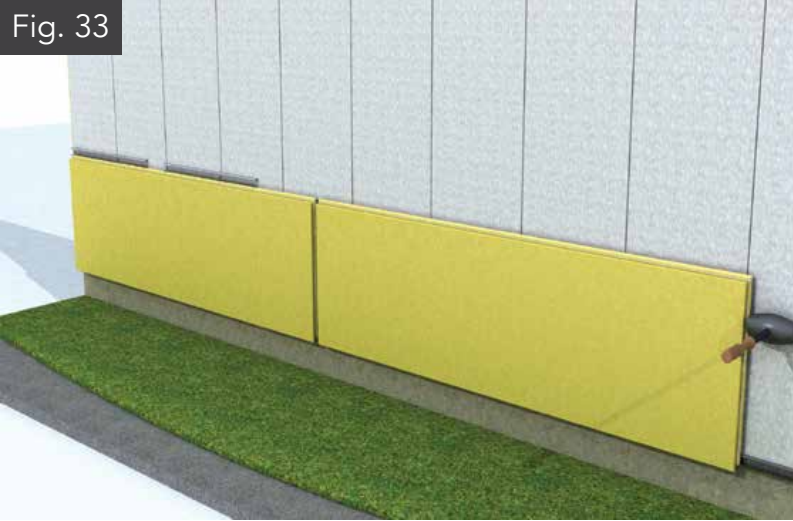

Fig. 34



Fig. 35



STRUCTURAL INSULATING PANELS (SIP)

In general, the steps mirror those for stud wall applications. However, double fastening per each panel clip (minimum of 4 screws per clip) is required as there are fewer or no studs to secure the system.

There must be about 2.5 clips per AWP-1818 edge, with vertical joints spanned by Panel Clips and the Joint Tab Attachment seated in and fastened to the Panel Clip at the lower right corner of each panel.

PRE-ENGINEERED METAL BUILDINGS (PEMB)

Refer again to general requirements concerning PEMB installations in the *Framing and Sheathing Requirements* section.

With metal panel ribs spaced no more than 12" o.c., install AWP in the same manner as with stud wall applications but with Panel Clips fastened to each rib they reach. Screws (#10x1") applied at no more than 12" o.c.

There must be about 2.5 clips per AWP-1818 edge, with vertical joints spanned by Panel Clips and the Joint Tab Attachment seated in and fastened to the clip at the lower right corner of each panel.

STACKED AND STAGGERED PANEL LAYOUTS

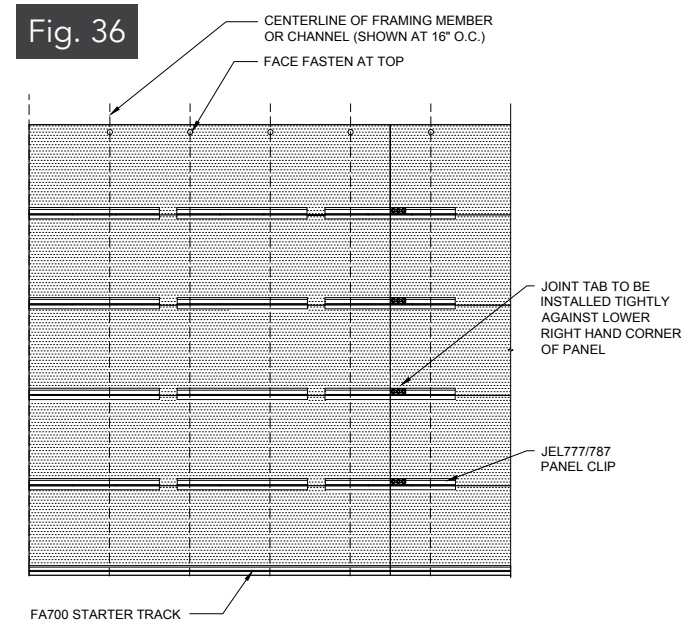

26" CLIP PLACEMENT FOR STACKED PANEL LAYOUT

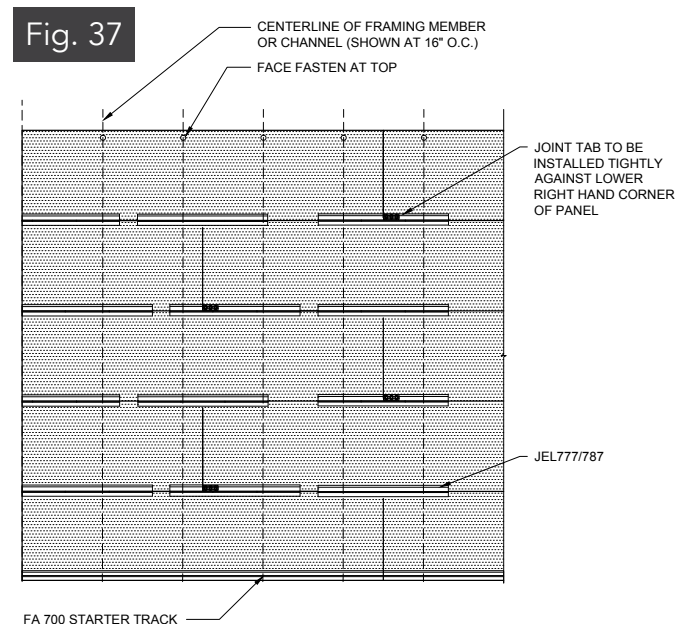

26" CLIP PLACEMENT FOR STAGGERED PANEL LAYOUT

INSIDE CORNERS, WINDOWS, & DOORS ALL APPLICATIONS

Appropriate flashing and moisture management best practices must be used to prevent moisture penetration at all inside corners, doors, and windows. Refer to window/door manufacturer requirements and local building codes. Cut and exposed panel edges must be primed or sealed with fiber cement sealer or paint.

Fig. 38



Fig. 39



INSIDE CORNERS

SINGLE FLANGE SEALANT BACKER

Decide primary line of sight in order to minimize visibility of the sealant joint. Install the panel (ship-lapped edges at the joint will need to be cut off) on the front wall (more visible) first. Ensure panel is butted up tight to the inside corner wall. Fasten the Single Flange Sealant Backer onto the side wall right up against the front wall panel's edge at 12-14" o.c.

Install side wall panel directly against the sealant backer and secure with Panel Clips. Fill space with sealant. (Fig. 38-40)

TRIM BOARDS

Install trim boards at inside corner first and butt cut panel edges to Single Flange Sealant Backer. Add ASTM C920, Class 35 (min.) compliant sealant to the gap.

Fig. 40

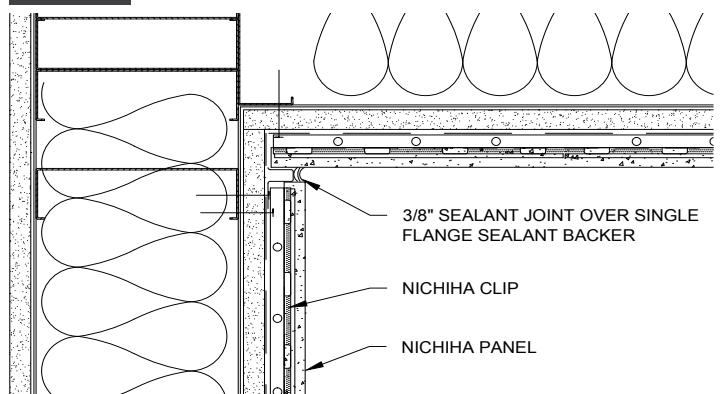

WINDOW SILLS

JE310 FINISH CLIP

For recessed windows, add a flashing where the panels will terminate so the top edges are covered or capped at the sill.

Remove the top ship-lapped edge of the panel at the window sill, cutting the panel to the required height, and route grooves into panel top at appropriate width to coincide with framing members. (Refer to *Finish Clip Usage* for biscuit joiner info.) Clean any dust off the panel. For windows narrower than a panel, only remove the portion of the panel edge directly under the window but accounting for a minimum 1/4" gap at both jambs.

Cut, routed panel edges must be sealed with 100% acrylic latex primer or paint, such as Kilz Premium or Kilz Max. Panel edge should be spaced a minimum 3/8" below a flush or overhanging window sill to accommodate the Finish Clip.

Fasten FS1005 Corrugated Spacer (5mm) at stud locations before setting panel into place. Seat Finish Clips into grooves and fasten at each stud location, through Spacer, to secure panel into place.

If the top edge of the panel is fully sheltered under the sill, it is not necessary to seal the 3/8" gap. For better system performance, Nichiha recommends the vented approach. (Figure 41)

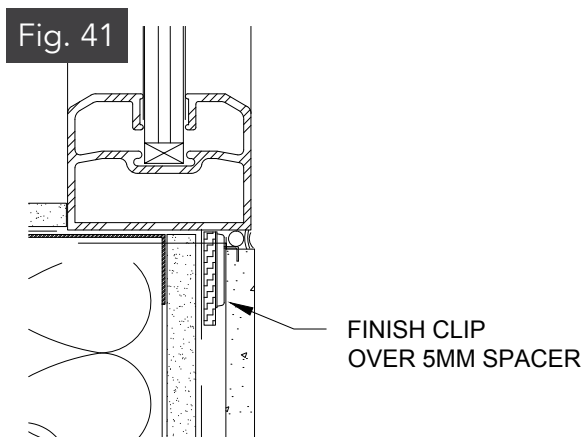

FACE FASTENING (J-MOLD OPTIONAL)

For recessed windows, add a flashing where the panels will terminate so that the top edges are covered or capped at the sill. As needed to match the window width, remove panel top ship-lapped edge, cutting the panel to the required height to fit below the window sill, leaving a 1/4" gap between the top of the cut panel edge and the window sill or trim board.

Cut, routed panel edges must be sealed with 100% acrylic latex primer or paint, such as Kilz Premium or Kilz Max. Clean any dust off the panel with a clean, soft, dry cloth.

Add FS1010 Corrugated Spacer (10mm) at stud locations, set the panel on the clips of the panel(s) below, and then face fasten top, cut edge of panel at the sill. Keep screws 1" below panel edge. This will avoid cracking or breaking the panel. A best practice is to pre-drill the panel before fastening.

If the top edge of the panel is fully sheltered under the sill, it is not necessary to seal the 1/4" gap. For better system performance, Nichiha recommends the vented approach. (Figure 42)

J-Mold or other trim channels can be included at a sill but must be placed on the panel edge prior to face fastening panel so that the trim is fastened simultaneously.



WINDOW/DOOR JAMBS

A minimum gap of 1/4" is required when butting panels into windows, doors, and trim boards. Refer to window/door manufacturer guidelines for spacing trims around openings.

SINGLE FLANGE SEALANT BACKER:

Install the Single Flange Sealant Backer first, butting to the door/window jamb or trim pieces prior to installing the panels.

The Single Flange Sealant Backer must be fastened a minimum of 12" to 14" o.c. to studs, blocking, or structural sheathing.

Cut panel to appropriate width, at least removing ship-lapped edge. Remember to clean freshly cut panels with a soft, *dry* cloth.

Install panels and fill gap with ASTM C920, Class 35 (min.) compliant sealant. (Figure 43)

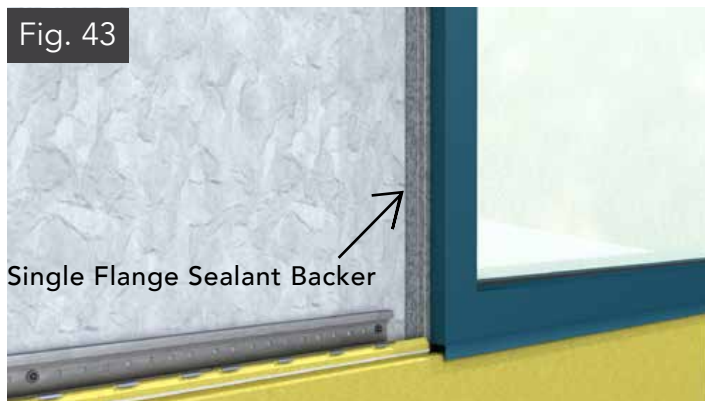

J-MOLD: Pre-install J-Mold trim with a 1/4" gap between it and the window/door jamb, or per window manufacturer instructions. Panels must fit completely within trim, with no exposed panel edges, but leaving a 1/8" space between panel edge and J-Mold.

Lastly, add closed-cell foam backer rod and sealant to the gap between the J-mold and jamb, if applicable.

NICHIHA CORNERS AT RECESSED JAMBS:

Nichiha Corners can be used to wrap recessed window jambs. Corners have returns of 3-1/2" (face dimension). Cut the pieces as needed for shallower returns but it must be of sufficient depth for use of a clip segment.

Wrap the base of the jamb with cut pieces of Starter Track (or FS1010 Spacer if face fastening). Install Corner pieces at jamb prior to main panels using cut Panel Clips (refer to *Cutting Panel Clips* section). Cut clips must retain at least one downward panel engagement flange.

Install Single Flange Sealant Backer with the sealant bump against the Corner piece, fastening at 12" - 14" o.c. along the fastening flange. (Figure 44)

Where Corner pieces meet the termination point at the window, leave a minimum 1/4" gap and add 1/2" closed-cell backer rod and sealant.

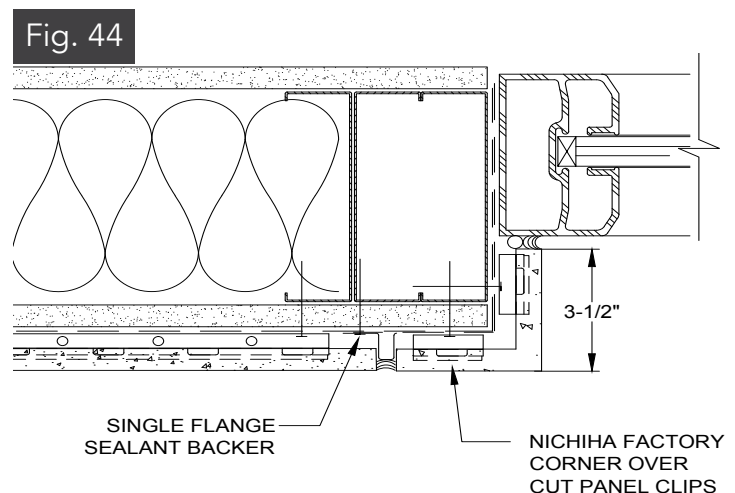

WINDOW/DOOR HEADERS

STARTER TRACK:

When starting a course of whole panels above a window or door, add flashing and Horizontal Starter Track at the header, installed with fasteners at each framing member. Add flashing tape to seal flashing to the WRB. (Figure 45)



FACE FASTENING:

When adding a cut panel above the opening, install flashing and corrugated Spacer first and then face fasten panels at each framing member. Add flashing tape to seal flashing to the WRB. Keep fasteners a min. 1" from edge. (Figure 46)

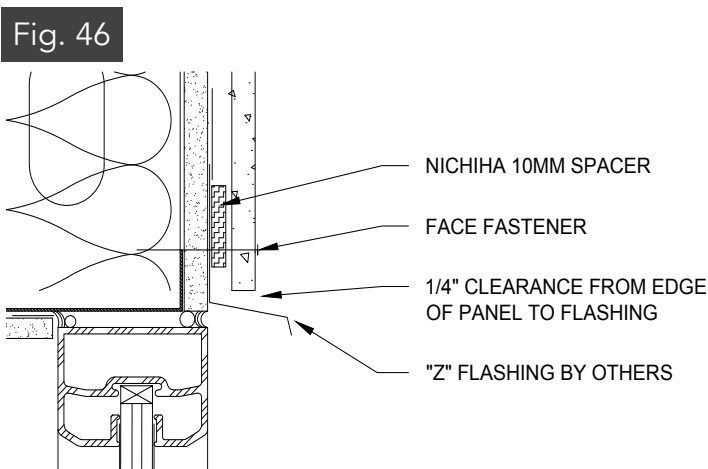

OUTSIDE CORNERS

There are several Nichiha recommended outside corner installation options:

- Nichiha Corners
- Fiber Cement and PVC Trim Boards
- Metal (Open Outside, Corner Key) and Vinyl Trim

Appropriate flashing must be used as required to prevent moisture penetration on outside corners.

NICHIHA CORNERS:

Install Nichiha Corners prior to panels. *Corners may only be used in vertical applications.*

Set Corner on the Starter Track and secure with two 1-1/2" cut Ultimate Clips that each retain a downward panel engagement flange. Refer to *Cutting Panel Clips* section. Place one clip on each side of the Corner and secure with fasteners into framing/structure.

Place the next Corner on top of the first, fitting the ship-lapped edges together over the clips. Secure the top edge in the same manner with two Ultimate Clip 1-1/2" segments. (Figure A)

Continue up the outside corner, stacking and securing the Corner pieces.

The top Corner will be cut to the appropriate height and face fastened over 10mm Spacer.

Add Double Flange Sealant Backer behind the Corners on both sides, all the way down from the top of the wall section to the Starter Track. Secure Sealant Backer to structure every 12-14" on the exposed fastening flanges. (Figure B)

After all the panels have been installed, apply ASTM C920, Class 35 (min.) compliant sealant to the Sealant Backers.

A

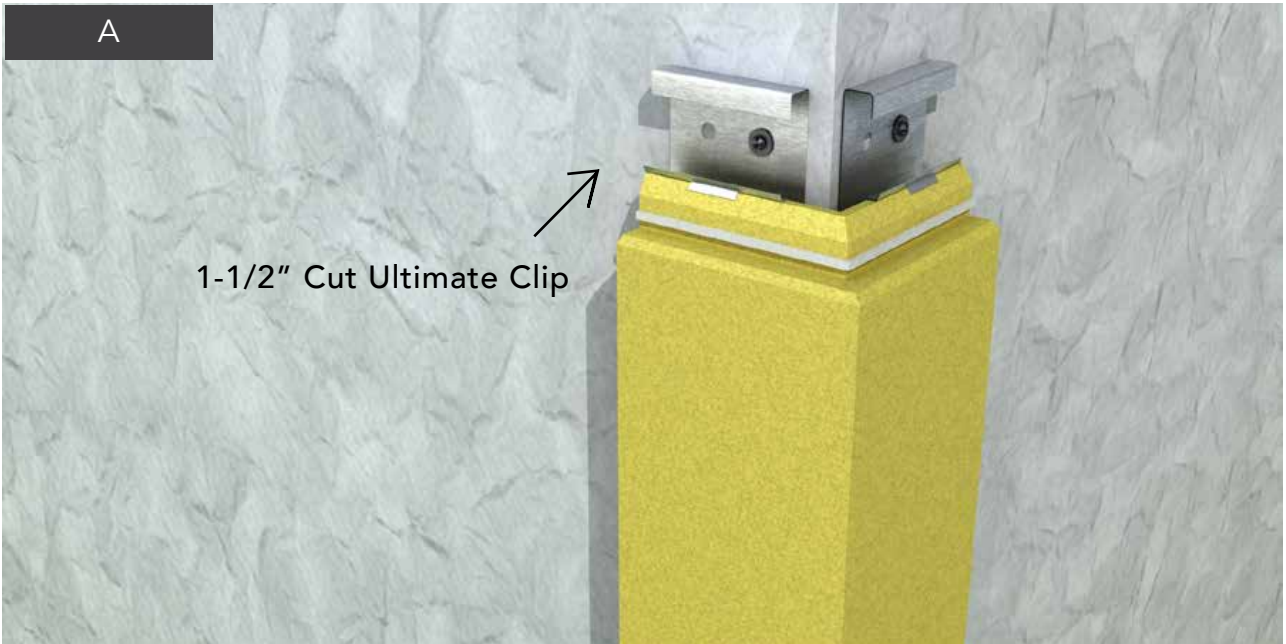

1-1/2" Cut Ultimate Clip

B



Double Flange Sealant Backer

FIBER CEMENT & PVC TRIM BOARDS

Nichiha manufactures a full line of fiber cement trim boards - NichiTrim™, which are available in the Southeast U.S. Refer to Nichiha.com for more information.

When panels are to be butted to fiber cement, wood or other trim pieces, use Nichiha Single Flange Sealant Backer between them.

Apply sealant compliant with ASTM C920, Class 35 (min.).

METAL & VINYL TRIM

Install trim channel, such as Nichiha Corner Key or Open Outside Corner, in accordance with manufacturer's installation instructions. Install prior to panels and fasten with corrosion resistant fasteners through trim flanges every 12-16" into studs or corner blocking. Stagger fasteners on alternating sides.

Cut off terminal panel ship-lapped edge to fit panel into channel trim so that panel edges are not exposed. Leave a 1/8" space between panel edge and center flange of trim.

Refer to *Vertical Control/Expansion Joints*.

Nichiha metal trim pieces are each 10 feet in length. To cut metal trim, a non-ferrous carbide miter saw blade is appropriate. When butting/stacking metal trim pieces, add a bead of polyurethane sealant at the seam/joint.

Metal trim can be pre-finished when purchased to match Illumination Series and some standard panel color(s). Otherwise, for field painting metal trim, use Direct to Metal (DTM) paint. See Tamlyn's XtremeTrim Painting Guide.

(Figure 50)

Fig. 50

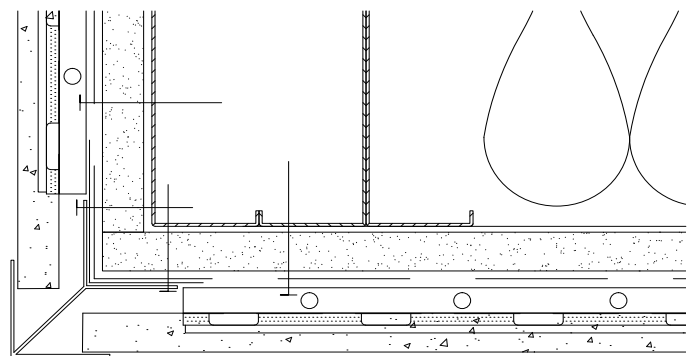

Corner Key Trim

NON-90-DEGREE CORNERS

Corners other than 90 degrees can be achieved with custom metal trim, butting panels to trim board with a minimum ¼" sealant gap, or with the use of Double Flange Sealant Backer (refer to *Vertical Control/Expansion Joint* section) to set cut panel edges at the desired corner angle. Miter cut panel edges as needed to create uniform sealant joint.

The Double Flange Sealant Backer detail can be utilized to accommodate use of AWP on segmented, radius-like walls. Do not attempt to curve AWP. Contact the Nichiha Technical Department for assistance.

VERTICAL CONTROL/ EXPANSION JOINTS ALL APPLICATIONS

Vertical Control/Expansion Joints are required within 2-10 feet of outside corners (on both sides of corner) and approximately every 30 feet thereafter.

Projects using Nichiha Corners (see Figures A and B on page 23) satisfy the 2-10 Rule but still require expansion joints roughly every 30 feet beyond the Corner joints.

For example, a 60-foot wall with two outside corners would require three vertical control joints: one near each outside corner and one towards the center.

Install vertical control joint (Nichiha Double Flange Sealant Backer) to butt up against the panels at a pre-determined joint location and secure the joint to substrate on one side (the right side flange) at 12" - 14" o.c. Double Flange Sealant Backer must be fastened to plywood/OSB sheathing, framing/furring member (added if necessary to pre-planned joint locations), or blocking.

Panel ship-lapped edges must be cut off to achieve a tight fit against the sealant backer.

Install next panel to joint and secure with Panel Clips. (*Figure 51*)

Apply low-adhesive tape along the length of the panel and trim edges to protect panel from sealant and for a smoother look when the sealant is applied and tape removed.

Apply ASTM C920, Class 35 (min.) compliant sealant into the expansion joint, starting at the bottom and pushing sealant into the gap.

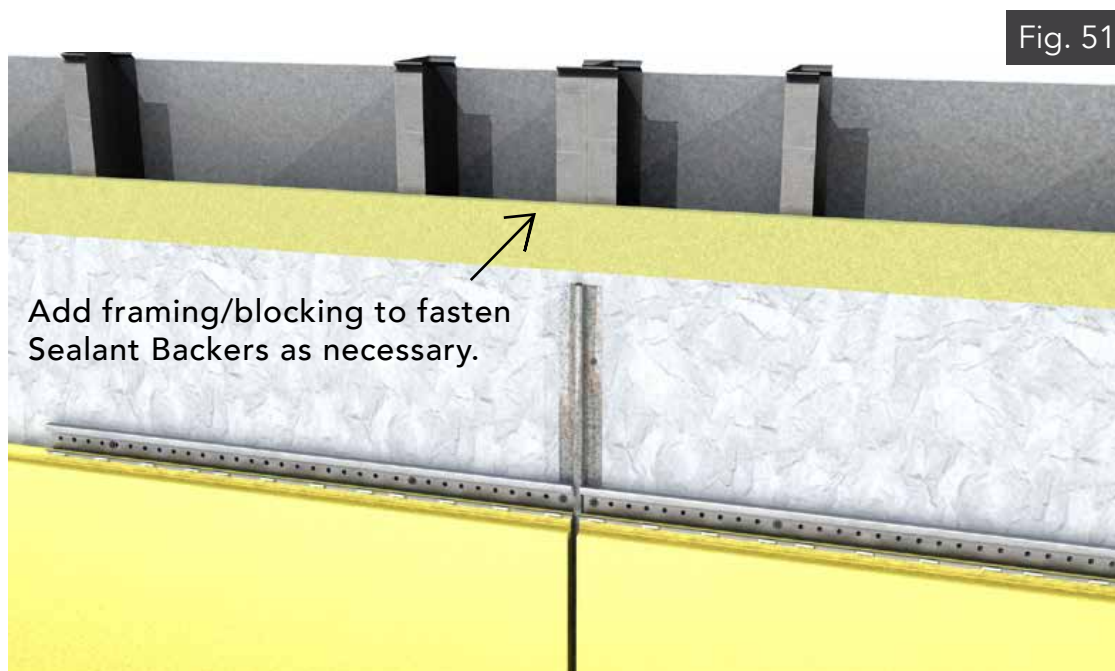

HORIZONTAL/COMPRESSION JOINTS ALL APPLICATIONS

Project designers must account for building compression when planning the cladding layout and incorporate horizontal/compression joints as appropriate. Nichiha is not liable for panel damage due to building compression. In general, Nichiha recommends such joints at each floor level.

With metal framing projects of more than three stories or 45 feet, add a joint approximately every 25 feet.

For wood framing projects of three stories or more, a joint is required at each floor.

Avoid spanning floor lines with panels at joints.

Please contact the Nichiha Technical Department for assistance.

INSTALLING A HORIZONTAL COMPRESSION JOINT

Install Essential Compression Joint Flashing or a heavier gauge z-shaped metal flashing or drip cap over the top edge of the course of panels terminating under the horizontal compression joint location.

Essential Compression Joint Flashing



Fasten Flashing at each stud location. A best practice is to add flashing tape to cover the top edge of the flashing and its fasteners.

The top ship-lapped edge of the bottom panel is cut and secured by face fastening (1" below panel cut edge) or use of the Finish Clip (JE310) with the appropriate Spacer behind: 10mm for face fastening, 5mm for Finish Clip.

Install Starter Track above trim or z-flashing such that the next course of panels sit at least 1/2 inch above the course below it. Remember the bottom ship-lapped edge of panels extend 3/4" below Starter, so the Starter will need to be installed at least 1-1/4" above the edge of the panel course below the joint.

Check for level.
(Figure 52)

Continue to install panels according to these guidelines with compression joints at the appropriate elevation(s).



Fig. 52

GARAGE DOORS & OTHER LARGE OPENINGS ALL APPLICATIONS

Install Starter Track 1" above garage door casing.

Establish a level line from the bottom of the Starter Track out to the side on both ends with a laser level.

Use this line to measure down the wall (each side of garage) to attach the Starter Track so that the panels will meet at the proper height.

Use Spacer (FS 1010) behind the panel at the bottom course (below the starter), which will be scribed to the contour of the surface.

Panels at the bottom course of the garage door opening must be face fastened to the studs.

When face fastening, always fasten at least 1" from all panel edges to avoid panel cracking or breakage. (Figure 53)

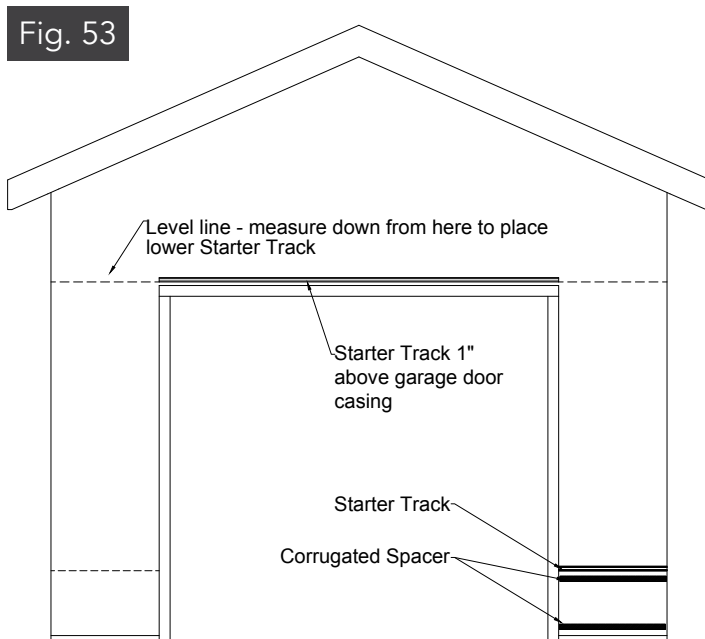

PENETRATIONS, RAILINGS, & SIGNAGE

Openings for small penetrations for pipes or conduits may be cut through a panel with the hole sealed with ASTM C920 compliant sealant. For larger penetrations greater than 1.5", it is best to block or frame out the opening.

Along the jambs of the opening install Single Flange Sealant Backer. Cut panel edge as needed to butt to Sealant Backer and add recommended sealant.

Underneath the opening block out, install FS1010 Spacer as needed for face fastening panel edge at framing locations. Terminate panel with 1/4" gap. Sealant here is optional, depending on the depth of the blocking. Above the penetration, add flashing and install FS1010 Spacer as needed for face fastening panel edge at framing locations. Ensure minimum 1/4" gap between bottom of panel edge and penetration blocking. Keep any face fasteners 1" away from panel edges. (Figure 54)

If installing railings or signage over AWP, ensure fasteners are secured through to framing or other structural support. Do not fasten any attachment only to panels.

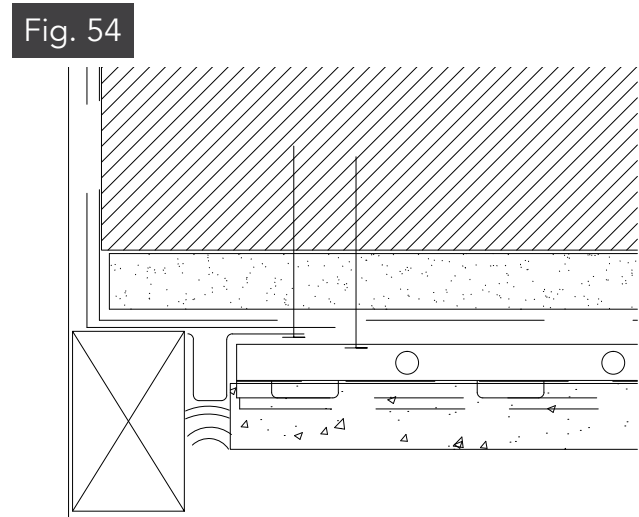

LAST COURSE ALL APPLICATIONS

Fasten Spacer (FS 1010) to studs at the top of the last panel course. This is needed to maintain the rainscreen without using the clips. Cut panels (horizontally) to properly fit at the roof line (or at the proper transition point). Face-fasten panels at the studs and through the green Spacer (FS 1010) all along the top. Apply low adhesive tape to panel at face fastening locations and remove only after applying patch and touch up paint. Pre-drill panels 1" from the top (cut) edge.

Fill counter-sunk fastener holes with exterior cementitious filler, such as MH Ready Patch® and later dab touch-up paint with cotton swabs. Remove painter's tape.

Alternatively, utilize the Finish Clip instead of face fastening. Cut panels horizontally to properly align with the roof line or transition point height. Use biscuit joiner to route notches into this cut edge, spaced to coincide with stud locations. Add 5mm corrugated Spacer (FS 1005) at Finish Clip fastening/stud locations prior to fastening clips. Set panels into place and seat/fasten a clip at each stud location.

Cover top panel row edge with roof cap/coping, where applicable. (Figure 55)

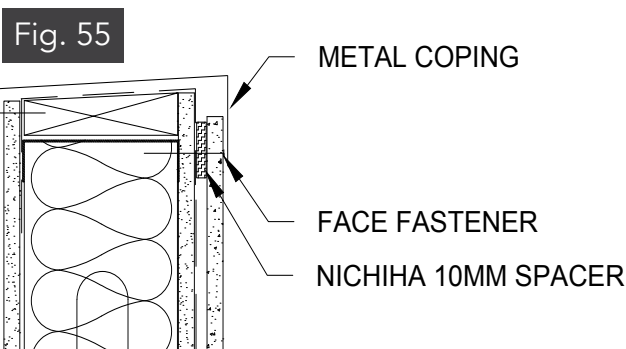

GABLE & OVERHANG

Allow a minimum of 1" clearance (as per local building codes) for AWP above a roof line.

At top, cut the panel to follow the slope of the gable. (Figure 56)

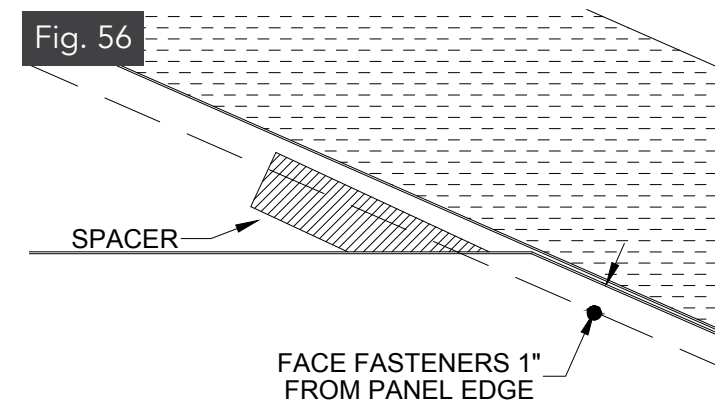

When installing soffit, the wall panels should be installed first, with the soffit installed over the panels.

Panels installed along gable edges must be face fastened. When adding face screws, apply fasteners at least 1" from any panel edge. This will avoid cracking or breaking of the panel.

All face-fastened panels must be shimmed out with FS 1010 Spacer.

Seal all cut panel edges with 100% acrylic primer or paint. Do not leave any panel edges exposed. Clean any cut panels to remove dust.

Essential Overhang Flashing may be used at the base of overhangs/bump-outs or porte-cocheres. Prior to panel installation, fasten Overhang Flashing at each stud location, beginning with corner segments. Main segments will slide under/overlap corner segments.

SLOPED GRADE/ PANELS BELOW STARTER TRACK

(Figure 58)

Where grade is sloped, begin with Starter Track at lowest possible continual level line and install as directed in this guide. To clad below Starter Track and to scribe to angled grade, take the following steps:

Add FS1010 Spacer below Starter Track. Below the Starter, if installing more than one course of panels, install the full-sized course up under the Starter and fasten upside-down Panel Clips underneath, with every framing/furring member covered by a clip. Face fasten top edge through corrugated Spacer. Keep fasteners 1" from panel edge.

Add the next course and fasten upside-down clips unless that panel or row is the final/terminal, cut/scribed panel or row. Face-fasten the bottom/cut course with backing corrugated Spacer. Maintain minimum clearances above grade: 2" above hardscape, 6" above soil. Paint, prime, or otherwise seal all cut, exposed panel edges. Clean panels after cutting with clean, dry cloth to remove dust.

If installing over a masonry/CMU foundation, furring is required. This should be taken into consideration when planning the depth of the exterior wall and cladding above so that the entire wall will have a uniform depth.

Use Joint Clip segments to join main segments together. After first piece is secured, add a Joint Clip, fastening through both it and the first main segment. The next main piece will slide behind the Joint Clip.

Position Overhang Flashing so that its bottom/return flange butts to or overlaps soffit. The bottom return portion must extend beyond the face of the facia substrate (Figure 57).

Essential Overhang Flashing & Joint Clip



Fig. 57

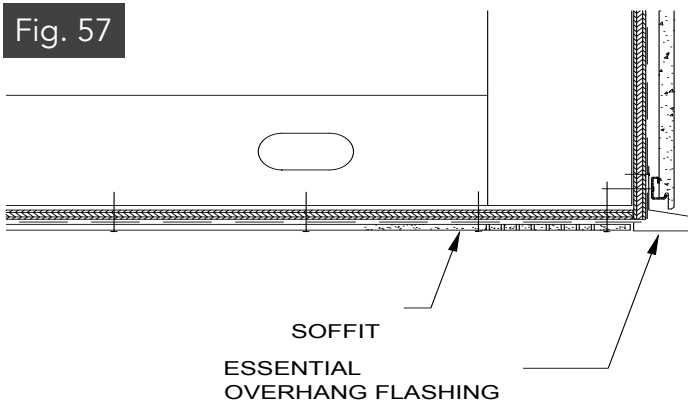
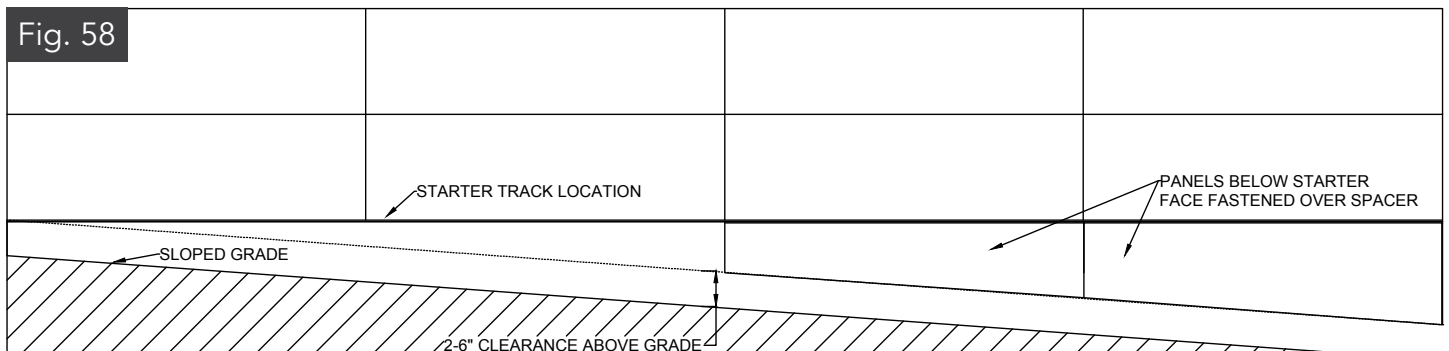

Fig. 58



CLEANING PANELS

After completion of the installation or for periodic maintenance, it may be necessary to clean panels.

When washing panels, use no more than 400 psi of water pressure at 10" to 12" away. **Do not pressure wash Illumination panels.**

To clean heavily soiled areas, a mild household detergent and/or soft bristle brush may be required.

Do not allow any detergent/cleaner to dry on panels. Rise immediately after cleaning.

PAINT TOUCH-UP

Touch up paint must be exterior grade 100% acrylic latex and can be color matched by taking a panel sample to your local paint or home improvement store.

One gallon of Illumination Series touch-up paint is supplied with your custom color panel order.

Apply low adhesive tape to panel face at face fastening locations and remove only after applying patch and touch up paint.

Where face fasteners have been used and patched by cementitious filler, use a cotton swab to lightly dab touch-up paint.

For scratches, use a cotton swab for small ones or 1" foam brush for longer ones, again using a dabbing motion rather than brushing in order to minimize the amount of paint applied.

REMOVAL OF EXTERIOR ACRYLIC LATEX PAINT

Wet Paint Removal - While the paint is still wet, flush the area with clean water. Use mild abrasion with a clean cloth or soft brush.

Semi-Dry Paint Removal - If paint has set, but not dried, flush and clean as above, followed by light scrubbing with alcohol to remove any remaining paint residue. Rinse with water and a clean cloth.

Dry Paint Removal - Please refer to paint removal guide in the next section.

OTHER PAINT & GRAFFITI REMOVAL

The following products have been tested on Nichiha panels* to aid in the removal of graffiti type markings. These citrus-based products can also be used for basic panel cleaning purposes. The panels were sprayed with an indoor/outdoor aerosol spray paint and left to dry overnight, and then the paint removal products were applied following the manufacturer's guidelines.

All products tested achieved good results. However, the outcome may vary depending on the amount of paint that needs to be removed. Be sure to follow all manufacturer's guidelines and first test in an inconspicuous area before working on a larger area.

Do not use these cleaners with Illumination Series.

**Nichiha is not liable for any damage caused by the use of these cleaners.*

Citristrip

www.citristrip.com

Products tested:

Citristrip Striping Gel - One Quart container

Citristrip Striping Aerosol - 18 oz. spray can

Goof Off Graffiti Remover

www.goof-off.com

Products tested:

Goof Off Aerosol - 16 oz. spray can

Goof Off - 22 oz. trigger spray bottle

Tagaway

www.tagaway.com

Product tested:

Tagaway - 32 oz. trigger spray bottle

Zinsser

www.zinsser.com

Product tested:

Zinsser Graffiti Remover and Stripper - 16 oz. trigger spray bottle

REPAIRING MINOR DAMAGE

Isolate the blemish with a low adhesive tape such as painters tape. This will help protect the surrounding area of the panel and aid in creating a more polished, clean repair. Lightly brush/abrade the surface within the taped off area in order to remove any loose material.

Carefully fill and smooth the resultant prepped area with cementitious patching material such as MH Ready Patch. Allow to dry/cure fully.

Gently smooth the patch and then apply touch-up paint to the affected area. Allow touch-up paint to dry and remove the tape.

PANEL REPLACEMENT

Set the depth of the circular saw blade slightly deeper than the panel so the saw blade does not cut into the building wrap or sheathing.

Make additional cuts into the damaged panel and break into pieces for easier removal of the damaged panel.

Remove damaged panel.

Cut 3/16" off the back ship-lapped edge at bottom of panel.*

Cut the right side ship-lapped edge off the panel.

Use a 10mm Corrugated Spacer and place it behind the new panel at bottom, just above exposed Panel Clips or Starter Track.

Prepare to set the new panel in place.

Lift panel into place by prying from the bottom upward. Pre-drill and face fasten panel with a screw into the framing members, 2" from panel bottom.

Fill countersunk screw heads with color-matching polyurethane sealant or cementitious patching material.

*If panel to be replaced is at the top course or under a window, cut top edge of panel as needed and leave bottom shiplap intact. Add Spacer at top of uncovered wall space.

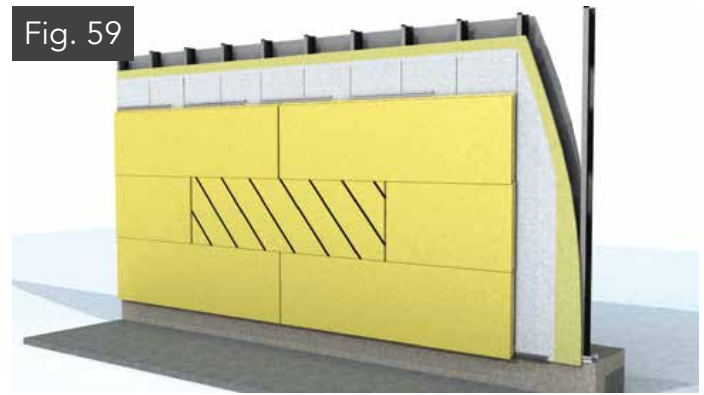

Fig. 60

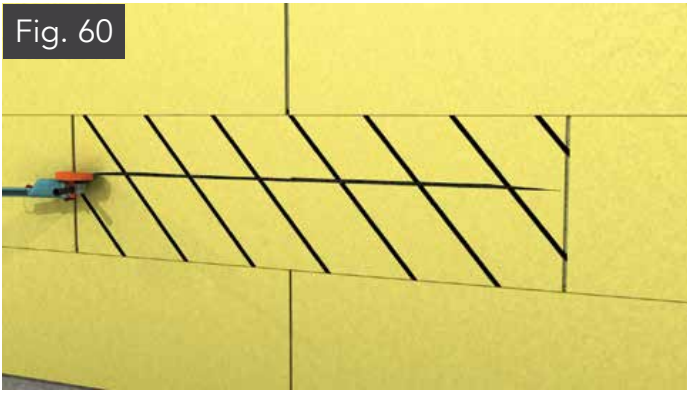

Fig. 61

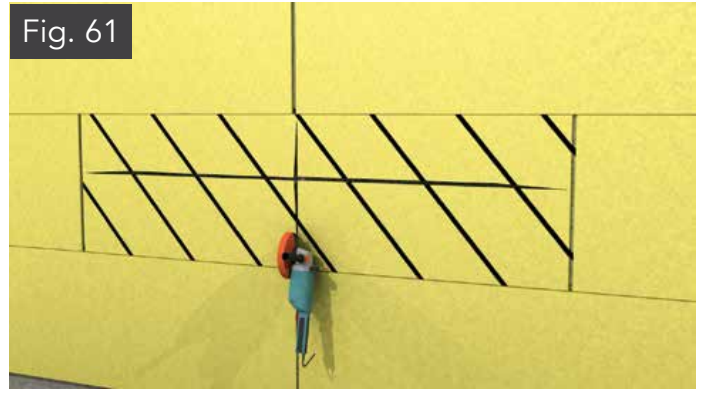

Fig. 62

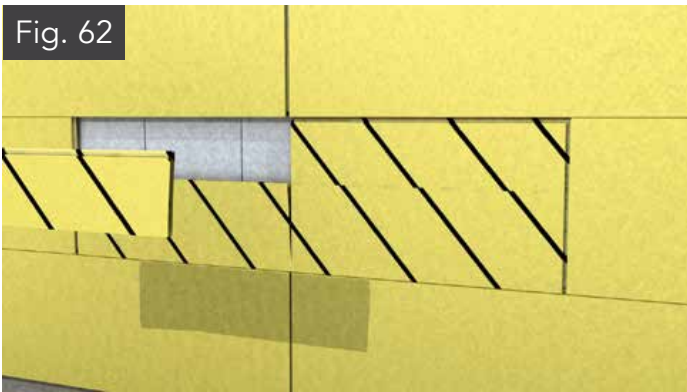

Fig. 63

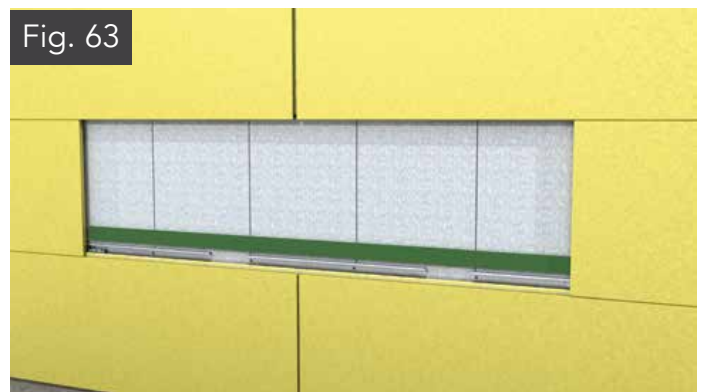

Fig. 64-A

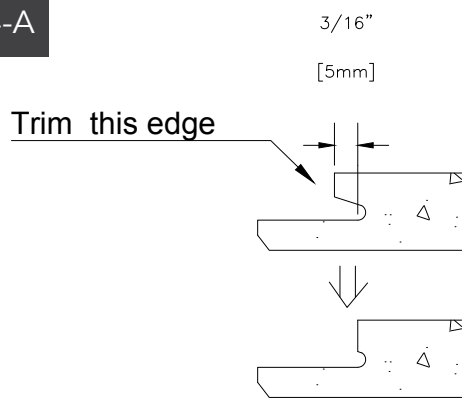

Fig. 65-B

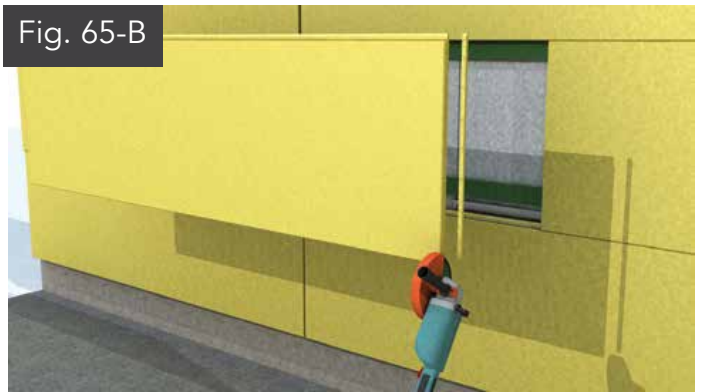

Fig. 66

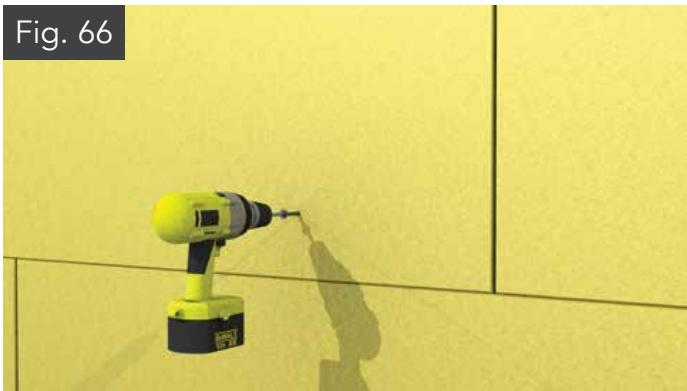

Fig. 67



Behind our Architectural SERIOUS TEC



EASY INSTALLATION:

Timesaving Clip Installation System that reduces construction time and minimizes mistakes.



NO MORTAR, NO MESS:

Prefinished panels that eliminate the need for messy mortar or costly masonry-skilled labor.



LOW MAINTENANCE:

No-fuss products. No ongoing cleaning and regular maintenance needed. Your customers get to create it then enjoy it for a long, long time.



ANY WEATHER PRODUCT:

Products that can be installed all year round.



ENGINEERED FOR PERFORMANCE:

Go beyond our durable panels and discover a meticulously engineered moisture management system that provides a vertical drainage point for air & moisture to exit.



*Watch our installation instructions come to life -
check out our install videos today!*

www.nichiha.com/awp_install_videos



al Wall Panels is some HNOLOGY...



The Ultimate Clip creates a hidden fastening system that all but eliminates face fastening. Installation is quick and easy and never requires specialty subcontractors.

Nichiha Architectural Wall Panels are lightweight, easy to handle and available in a virtually endless color palette and a diverse offering of textural finishes. They're also backed with the industry's strongest warranty.

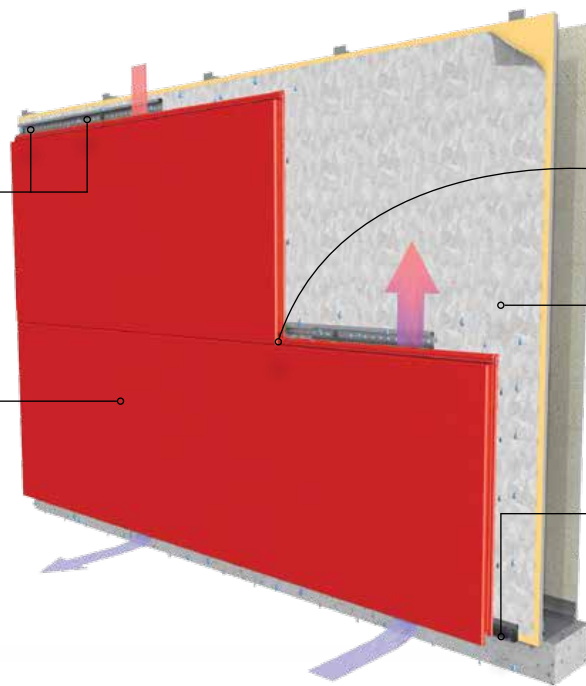

Nichiha's Joint Tab Attachment is designed to support panel lateral stability, helping vertical joints stay tightly closed. The tab fits in place easily and is fastened to the Ultimate Clip with provided screw.

Drained and Back Ventilated Rainscreen design allows water to escape and air to circulate, reducing the risk of mold and water damage inside the building.

The Ultimate Starter Track pulls double-duty. It ensures a fast, level installation and its patented drainage channel directs water out and away from the base of the wall.



LEVEL



RUBBER
Mallet

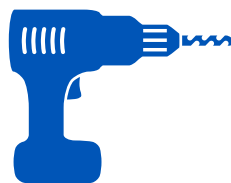

ELECTRIC
DRILL



CORROSION
RESISTANT
FLATHEAD
SCREWS



SAW WITH
FIBER CEMENT
BLADES

Never underestimate the power of really good tools

Whether you're an architect, a builder or a contractor, Nichiha wants to see to it that you have all the information you need to make your project go as smoothly as possible. The way we see it, we're partners.

Our website offers a comprehensive collection of technical information, Architectural details, in depth specifications and everything you'll ever need to know about installing Nichiha products. We invite and encourage you to visit our website at nichiha.com.

And by all means, if you have a troublesome question or comment, our ears are always open. Call us at 1.866.424.4421 or visit us at nichiha.com.

NICHIHA WARRANTIES

- Illumination Series Panels - 15-year limited warranty* on panels, 15-year limited warranty* on finish
- Architectural Wall Panels (Brick, Block, Stone, Wood, Kurastone) - 15-year limited warranty* on panels, 15-year limited warranty* on finish
- Metal Trim: Tamlyn warrants defective-free products for a period of 10 years for the original purchaser. Please visit tamlyn.com for detailed information on terms, conditions, and limitations

*See Nichiha warranties for detailed information on terms, conditions, and limitations. Visit nichiha.com for easy downloadable warranties or call toll-free 1.866.424.4421 for a copy.

Nichiha SDS are also available on our website.

Certification & testing:



Report
PER-14088



Florida Approval
12875



Miami-Dade
NOA No. 16-0404.18



WUI
8140-2029



Report
EC-58

Silica Dust Warning: NICHIHA products may contain some amounts of crystalline silica [a.k.a. sand, silicon dioxide], which is a naturally occurring mineral. The amount will vary from product to product. Inhalation of crystalline silica into the lungs and repeated exposure to silica can cause health disorders, such as silicosis, lung cancer, or death depending upon various factors. To be conservative, Nichiha recommends that whenever cutting, sawing, sanding, sniping or abrading the product, users observe Safety Instructions. For further information or questions, please consult the MSDS, your employer, or visit www.osha.gov/SLTC/silicacrystalline/index.html and www.cdc.gov/niosh/topics/silica. The MSDS for Nichiha products are available at www.nichiha.com, at your local Nichiha dealer or through Nichiha directly at 1.866.424.4421. FAILURE TO ADHERE TO OUR WARNINGS, MSDS, AND OTHER INSTRUCTION MAY LEAD TO SERIOUS PERSONAL INJURY OR DEATH.

9.17 WEB

