

284 5/8"
23'-8 5/8"

94 7/8"

94 7/8"

94 7/8"

15"

RAMBLERS WAY

EST 2009
RAMBLERS
WAY
CLOTHING for A GOOD LIFE
18 3/4"
38"

EST 2009
RAMBLERS
WAY
CLOTHING for A GOOD LIFE
18 3/4"
38"

EST 2009
RAMBLERS
WAY
CLOTHING for A GOOD LIFE
9 3/8"
19"

EST 2009
RAMBLERS
WAY
CLOTHING for A GOOD LIFE
36"
24"



284 5/8"
23'-8 5/8"

94 7/8"

94 7/8"

94 7/8"

15"

RAMBLERS WAY

24"

EST 2009
RAMBLERS
WAY
CLOTHING for A GOOD LIFE

36"

EST 2009
RAMBLERS
WAY
CLOTHING for A GOOD LIFE
18 3/4"
38"

EST 2009
RAMBLERS
WAY
CLOTHING for A GOOD LIFE
18 3/4"
38"

Assembled Marquee Signs

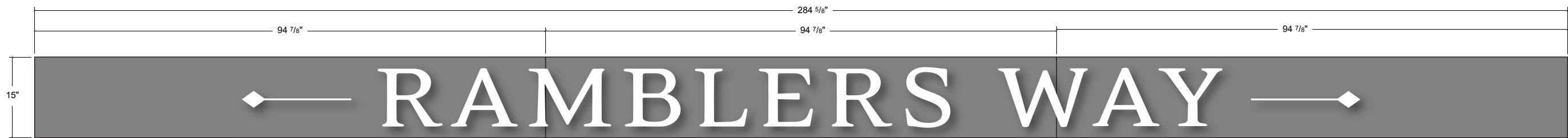

Parts

3/4" MDO with Epoxy sealed and finished edges. Paint all sides with Matthews Satin Acrylic Polyurethane. Color: Ben Moore HC-166 Kendall Charcoal match
 Individual panels mount with 6 concealed "L" brackets. All graphic content is screwed from behind prior to installation. EXCEPTION: "M" and "W" will be stud mounted flush with silicone AFTER panel mounting.



1/2" Solid Sintra PVC. Paint all sides with Matthews Satin Acrylic Polyurethane. Color: Ben Moore AC-41 Acadia White match.
 Shown reversed to indicate mounting holes. All graphic content is screwed from behind prior to installation. EXCEPTION: "M" and "W" will be stud mounted flush with silicone AFTER panel mounting.

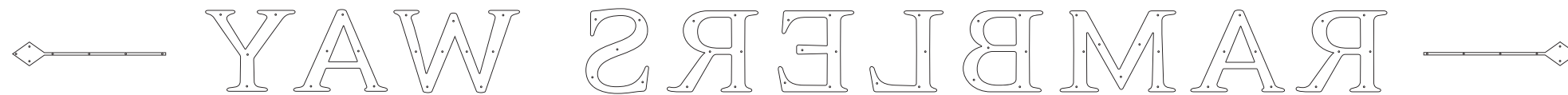

Mounting

Individual panels mount with 6 concealed "L" brackets.

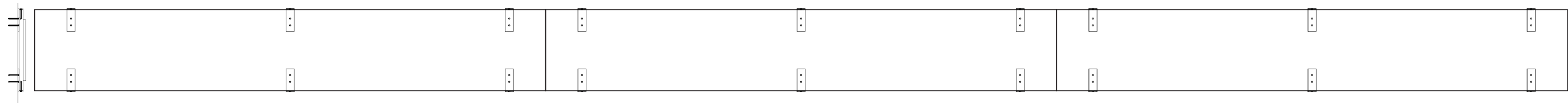

Ramblers Way
 Portland, Maine

Marquee Signs

Date:	Rev/Ver:	Drawn By:
9/22/17	V1.0	MLH



Windows
 Front applied cut vinyl to match
 Ben Moore AC-41 Acadia White
 Cut four sets

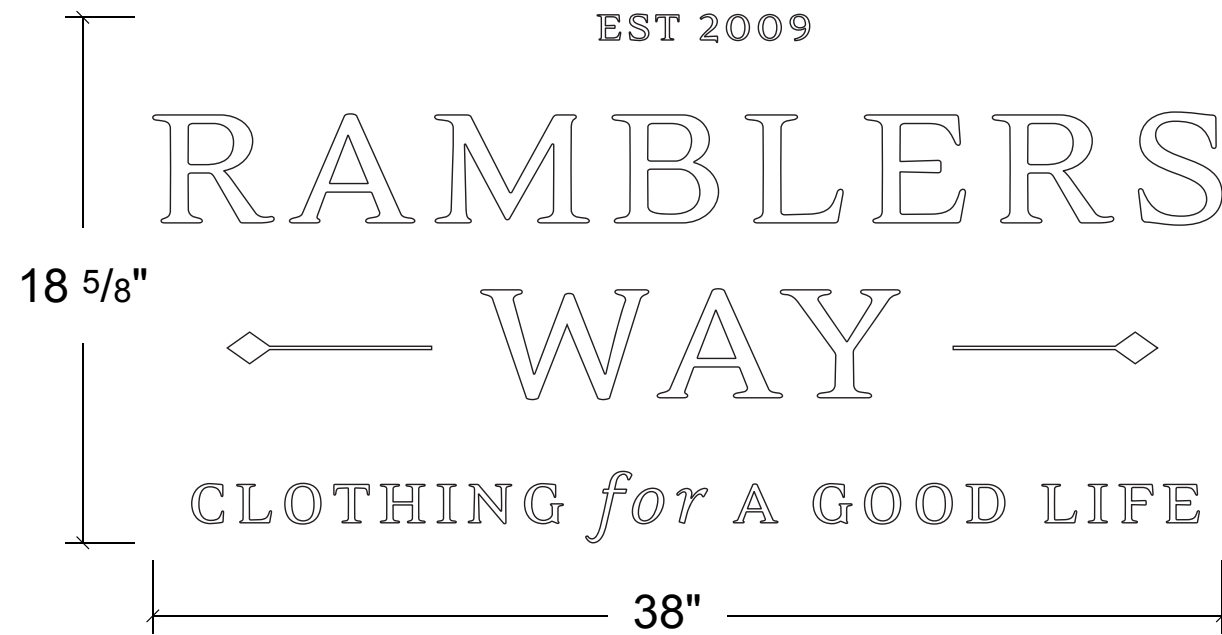

Door
 Front applied cut vinyl to match
 Ben Moore AC-41 Acadia White
 Cut one set



Ramblers Way
 Portland, Maine

Applied Cut Vinyl

Date:	Rev/Ver:	Drawn By:
9/22/17	V1.0	MLH



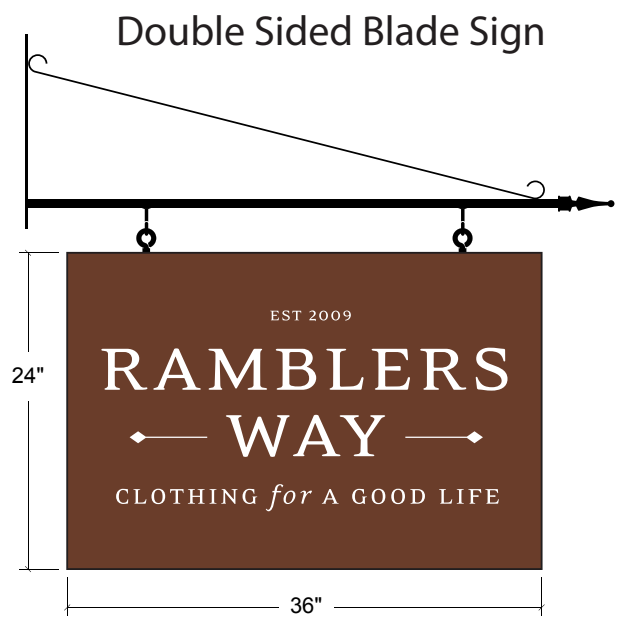

24 gauge Copper Sheet will be aged and clearcoated after Cutting.
Shown from back (cutting surface)

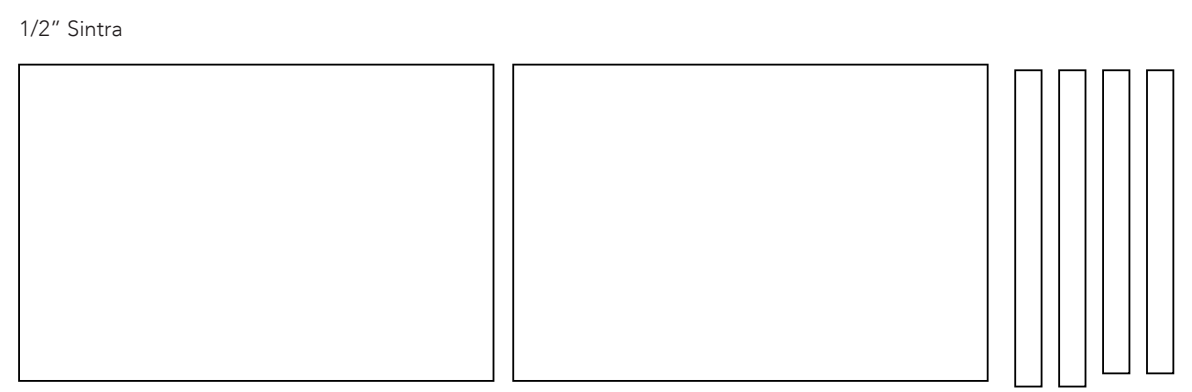
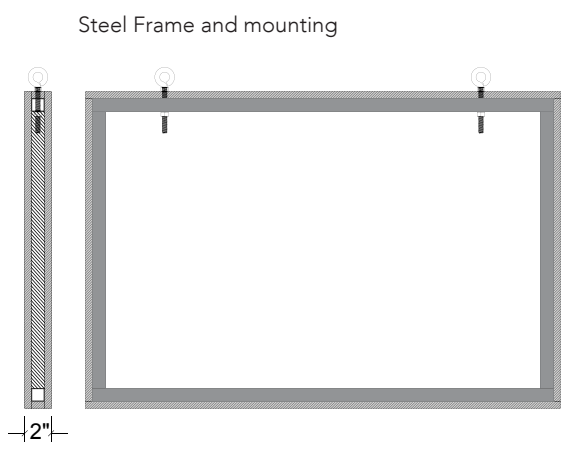
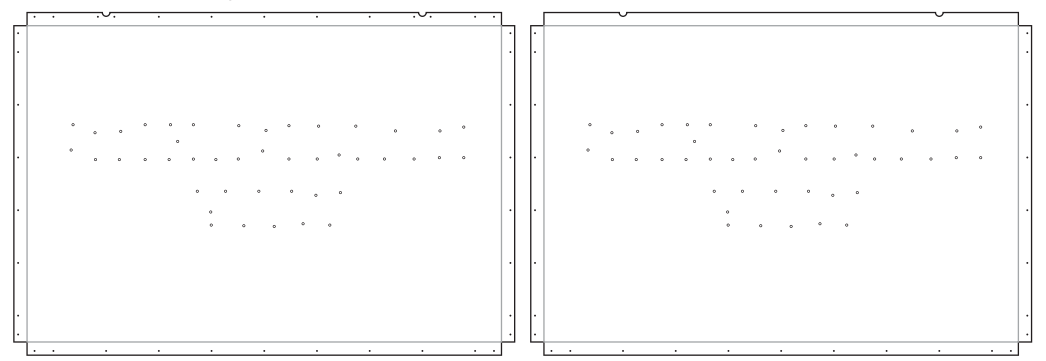

Front applied cut vinyl to match
Ben Moore AC-41 Acadia White
Cut two sets



1/2" Sintra Letters painted Ben Moore AC-41 Acadia White
Stud mount through copper sign face.



Ramblers Way
Portland, Maine

Double Sided Projecting sign

Date:	Rev/Ver:	Drawn By:
9/22/17	V1.0	MLH



1st floor wall sign



24 gauge Copper Sheet (1 sheet)

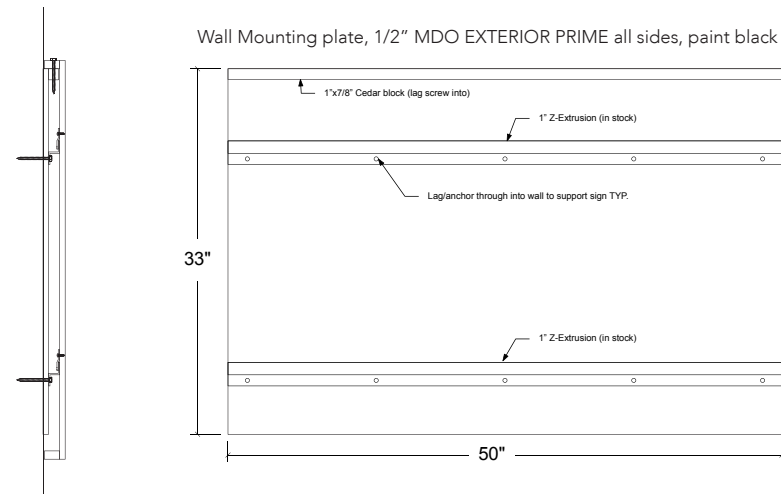
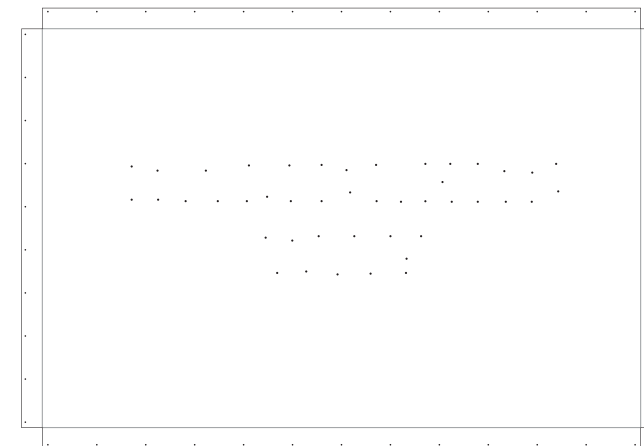

Wall Mounting plate, 1/2" MDO EXTERIOR PRIME all sides, paint black

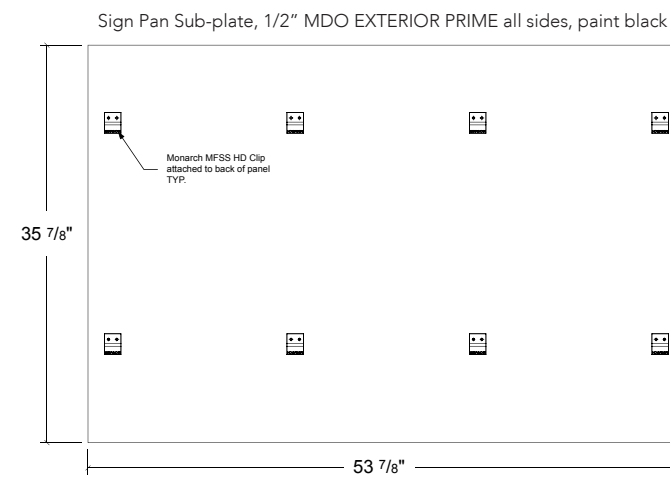

Sign Pan Sub-plate, 1/2" MDO EXTERIOR PRIME all sides, paint black

3/4" MDO Panel Returns

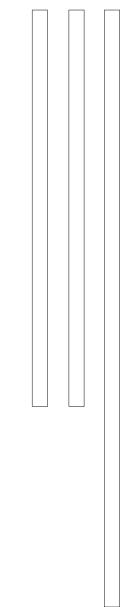

Front applied cut vinyl to match Ben Moone AC-41 Acadia White
Cut one set, align upper left corner.



1/2" Sintra Letters painted Ben Moone AC-41 Acadia White
Stud mount through copper sign face.



Ramblers Way
Portland, Maine

Wall Sign
1st floor

Date:	Rev/Ver:	Drawn By:
9/22/17	V1.0	MLH



Downstairs wall sign

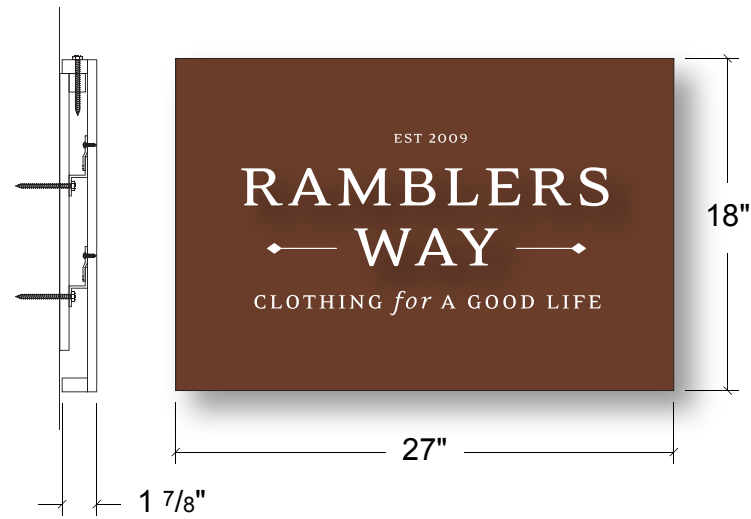

24 gauge Copper Sheet (2 sheets)
FLIP BEFORE CUTTING

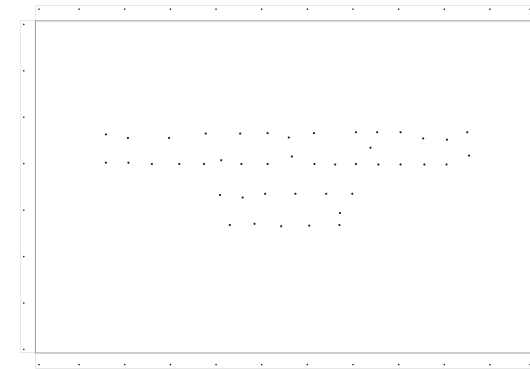

Wall Mounting plate,
1/2" MDO EXTERIOR
PRIME all sides, paint black

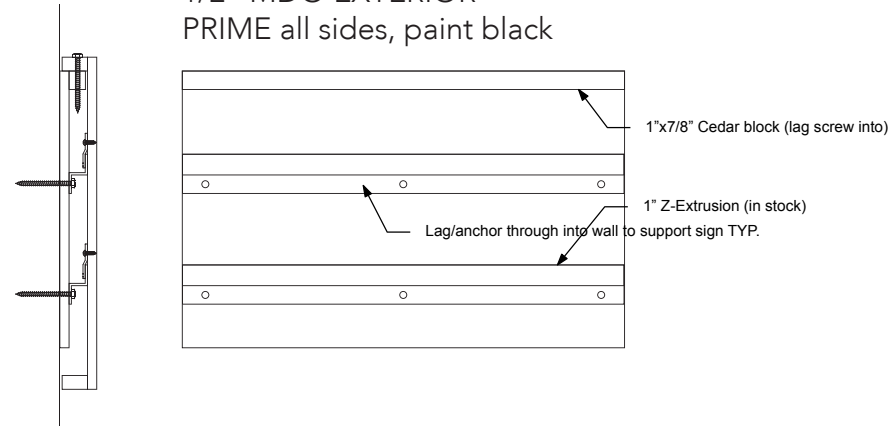

Sign Pan Sub-plate,
1/2" MDO EXTERIOR
PRIME all sides, paint black

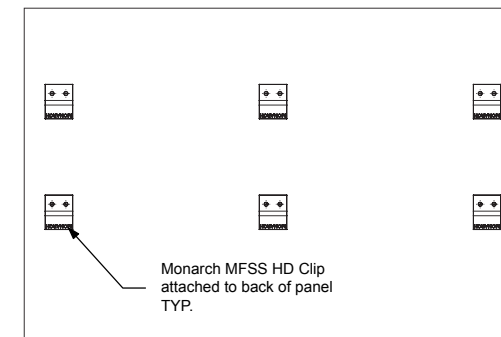

3/4" MDO Panel Returns



Front applied cut vinyl to match
Ben Moone AC-41 Acadia White
Cut one set, align upper left corner.



1/2" Sintra Letters painted
Ben Moone AC-41 Acadia White
Stud mount through copper sign face.



Ramblers Way
Portland, Maine

Wall Sign
Downstairs

Date:	Rev/Ver:	Drawn By:
9/22/17	V1.0	MLH

