

COLUMN SCHEDULE																
COL. NO.	C1	C2	C3	C4	C5	C6	C7	C8	C9	C10	C11	C12	C13	C14	C15	C16
LEVEL																
ROOF EL. VARIES																
THIRD FLOOR																
SECOND FLOOR						M10X33	M10X49	M10X49								
FIRST FLOOR	M10X33	M10X39	M10X45	M10X49	M10X54				M10X45	M10X39	M10X54					
BASE PL. TYPE	A	A	A	A	A	A	A	B	B	B	B					
BASE PL. SIZE "N" x "t" x "B"	16" x 1 1/4" x 1'-4"	16" x 1 1/2" x 1'-4"	16" x 1 1/2" x 1'-4"	16" x 1 1/2" x 1'-4"	16" x 1 1/2" x 1'-4"	16" x 1 1/4" x 1'-4"	16" x 1 1/2" x 1'-4"	18" x 1 3/4" x 1'-6"	18" x 1 3/4" x 1'-6"	18" x 1 3/4" x 1'-6"	18" x 1 3/4" x 1'-6"					

COLUMN SCHEDULE NOTES:
 1. ALL HSS COLUMNS SHALL BE ASTM A500 GRADE B.
 2. ALL WF COLUMNS SHALL BE ASTM A572 GRADE 50.

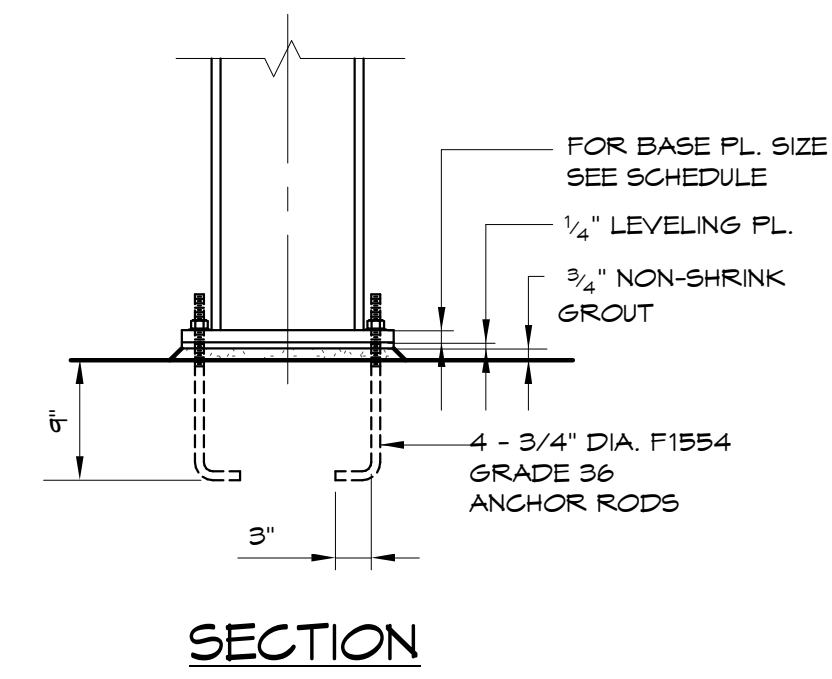

BASE PLATE - TYPE "A"

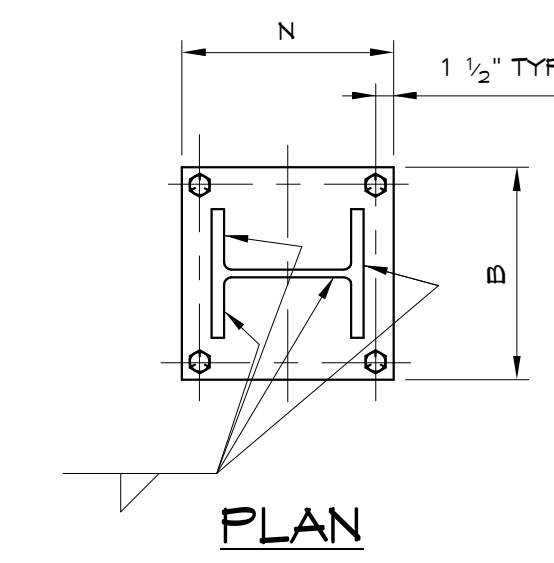
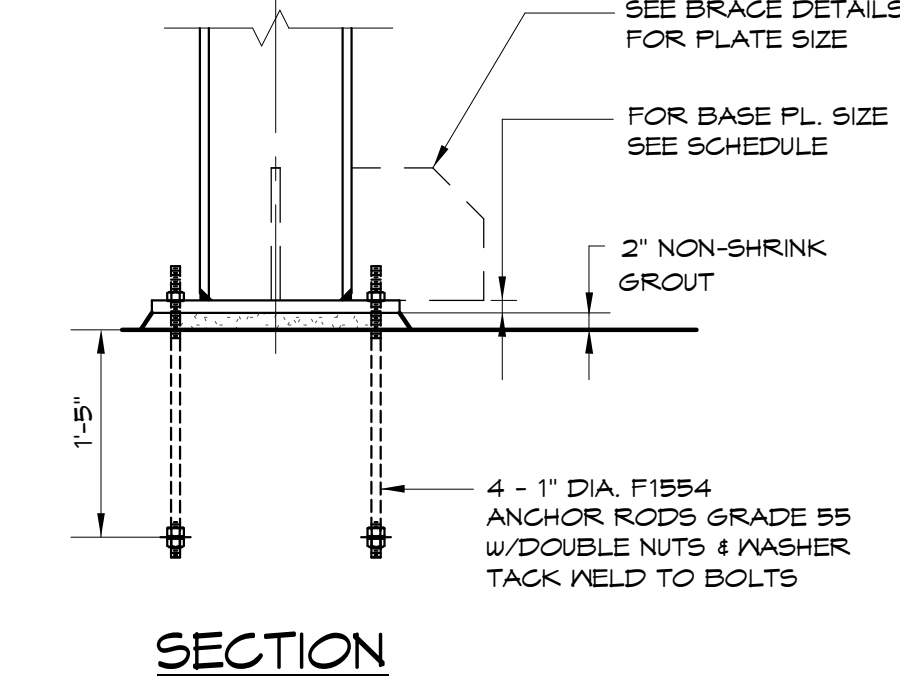
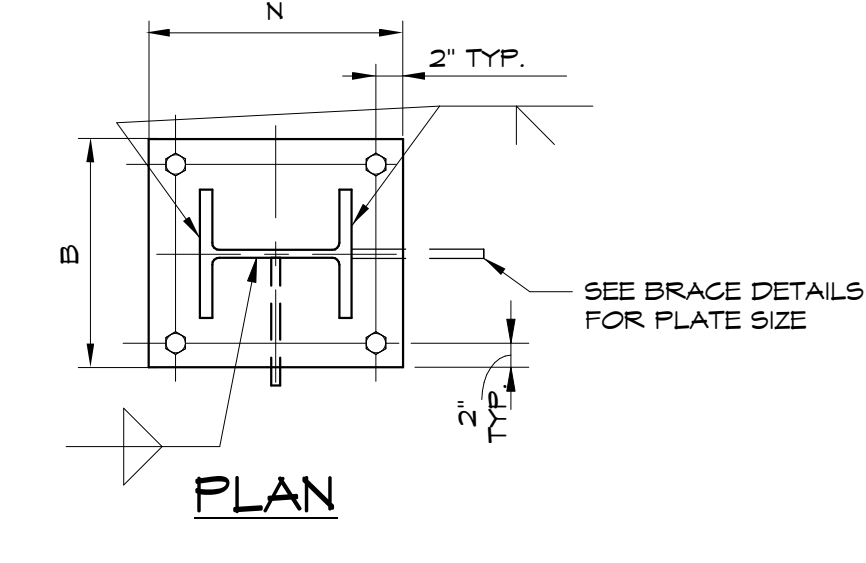

BASE PLATE - TYPE "B"

PIER SCHEDULE				
MARK	TYPE	SIZE "A"X"B"	REINFORCING	TIES
P1	A	24" x 24"	Ø-#8	#4@12"
P2	B	24" x 24"	Ø-#8	#4@12"
P3	C	24" x 24"	Ø-#8	#4@12"
P4				
P5				
P6				
P7				
P8				

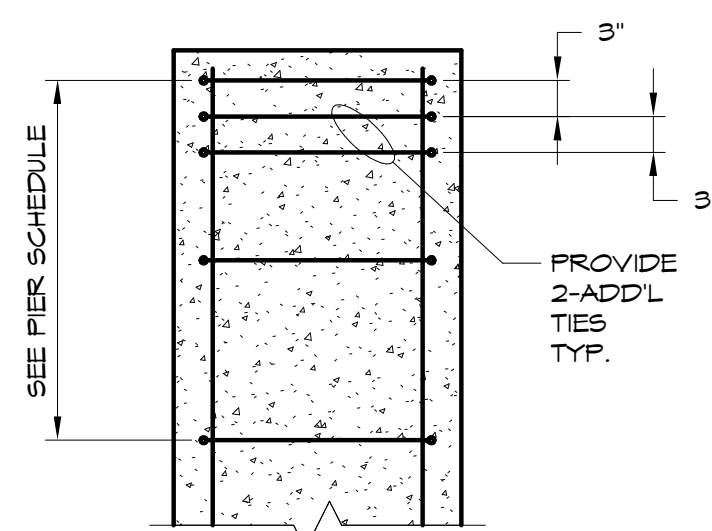

SECTION AT TYPICAL PIER
3/4"=1'-0"

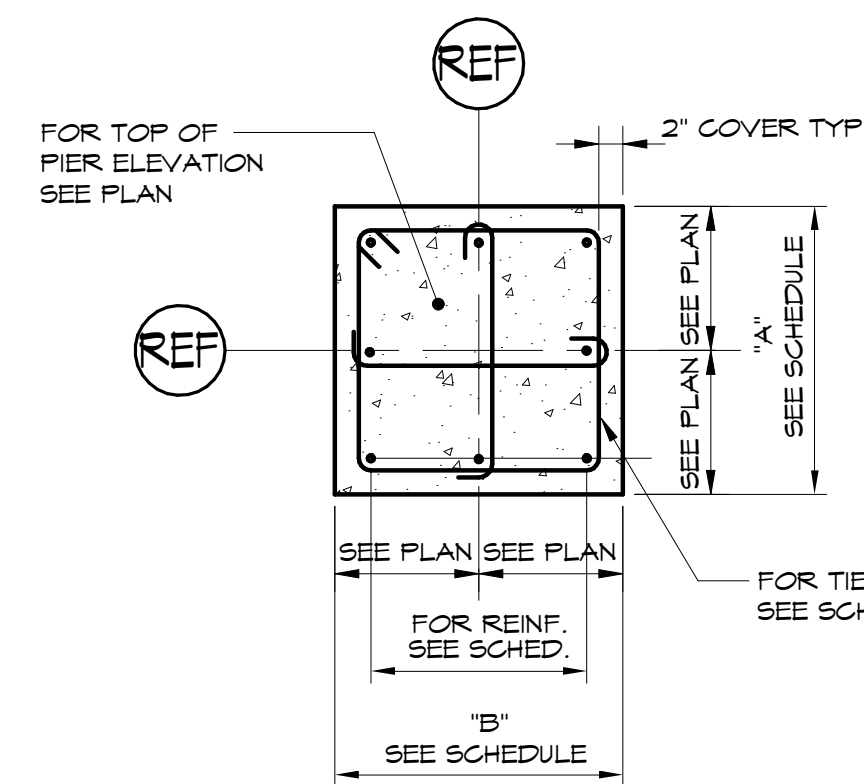

PIER DETAIL TYPE - A

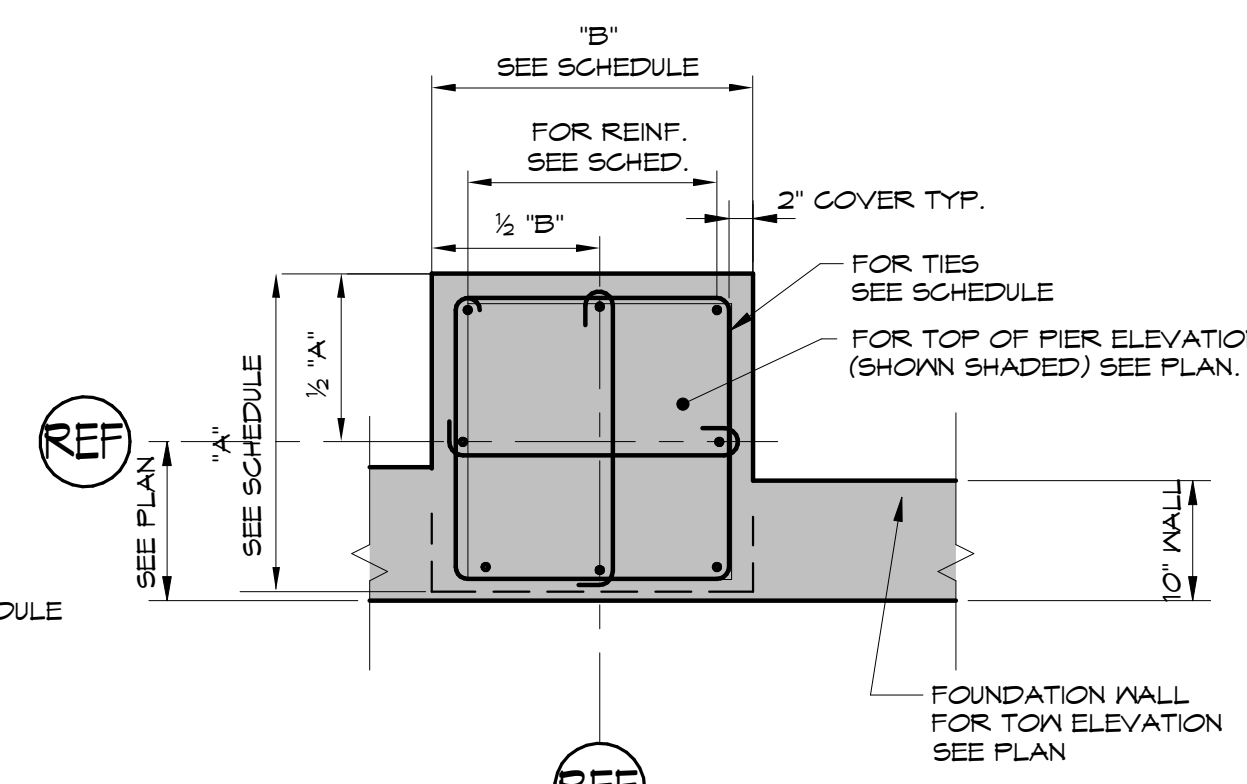

PIER DETAIL TYPE - B

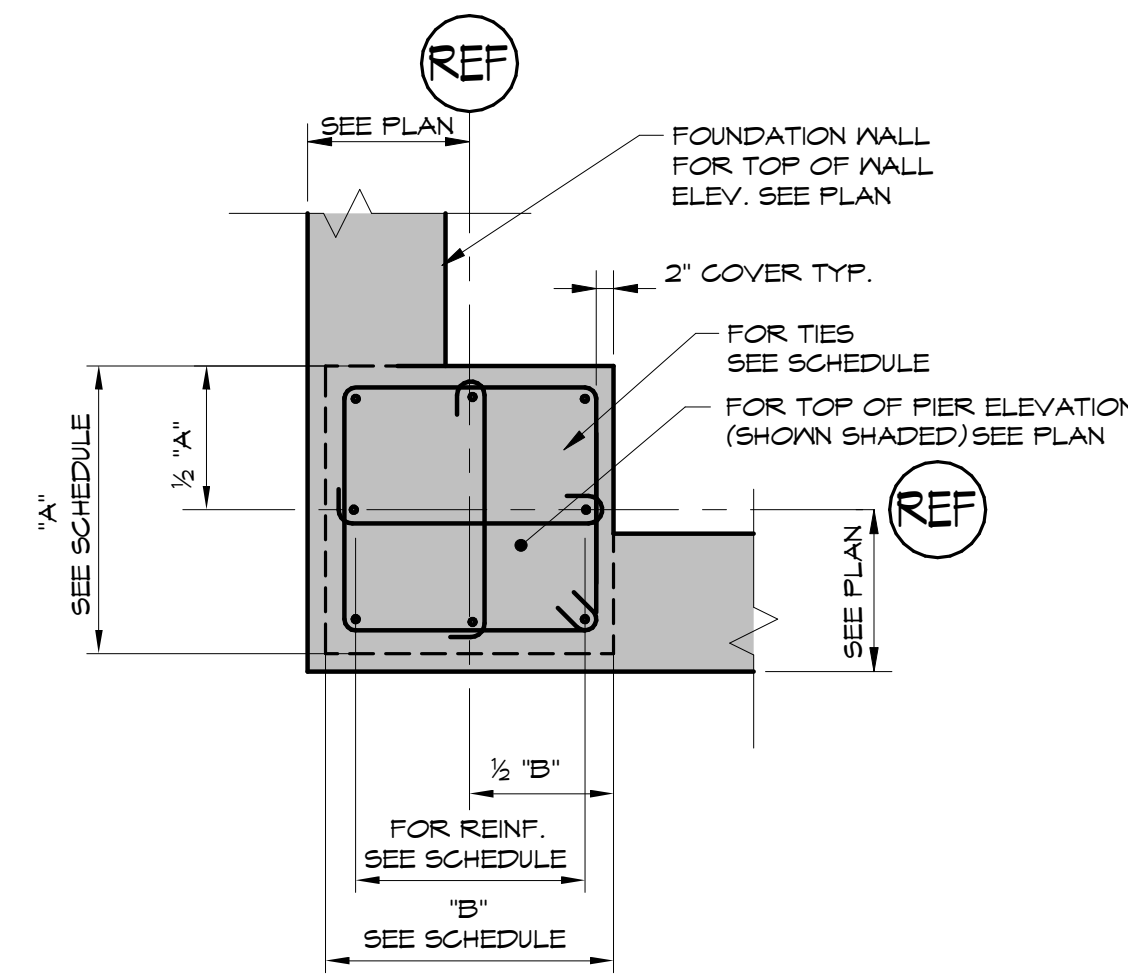

PIER DETAIL TYPE - C

Prepared For:
NewHeight Group
 118 Congress Street, Unit 401
 Portland, Maine

Consulting Engineer:
VEITAS VEITAS
 engineers
 638 Granite Street, Suite 101
 Business: 208.724.2214
 Tel: 208.724.2214 Fax: 208.724.2214

Architect:
ARCHETYPE
 architects
 48 Union Wharf Portland, Maine 04101
 (207) 775-6022 ARCHETYPE@ARCHETYPEPA.COM

Project:
LUMINATO
 Newbury Street Portland, Maine

Revisions:	FOUNDATION PERMIT
05/16/16	80% REVIEW DRAWINGS
06/07/16	100% STRUCTURAL DRAWINGS
06/24/16	100% CONSTRUCTION DRAWINGS
07/20/16	100% CONSTRUCTION DRAWINGS

Date: 04/19/16
 Scale: As indicated
COLUMN SCHEDULE & PIER DETAILS

S301