

13 STAIR WALL DETAIL  
3" = 1'-0"

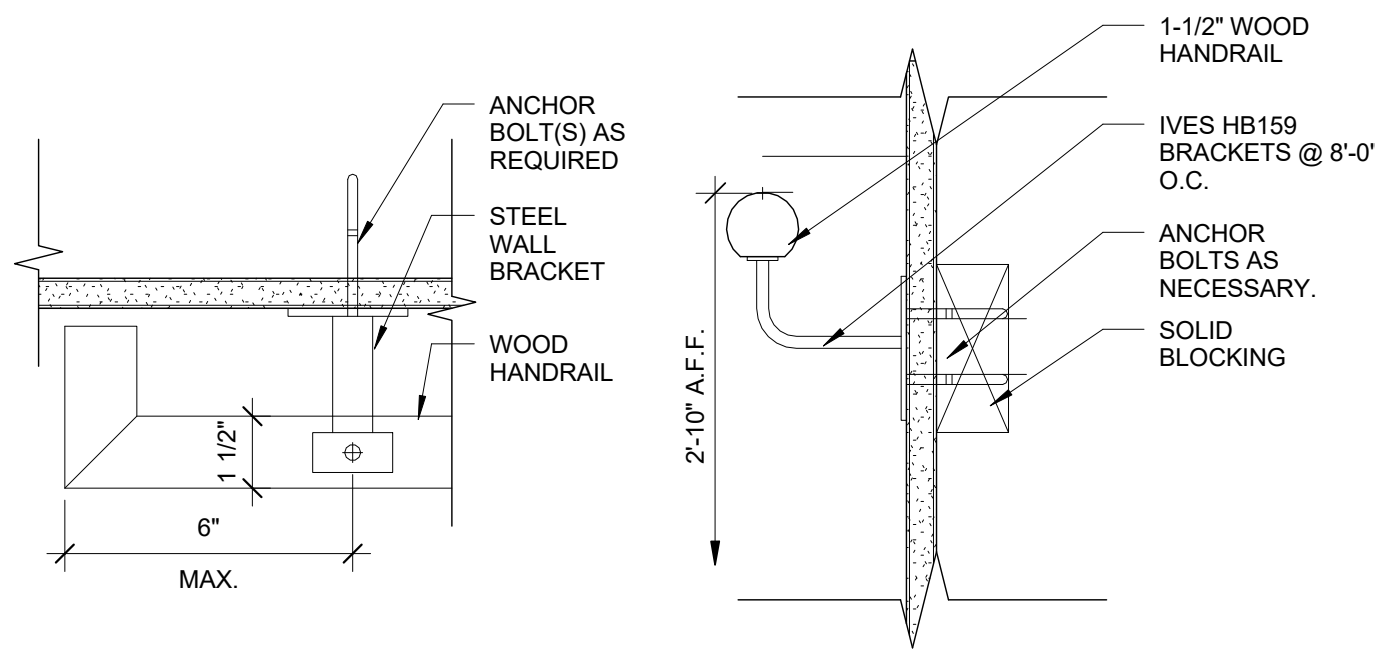

12 STAIR DETAIL - WOOD HANDRAIL  
3" = 1'-0"

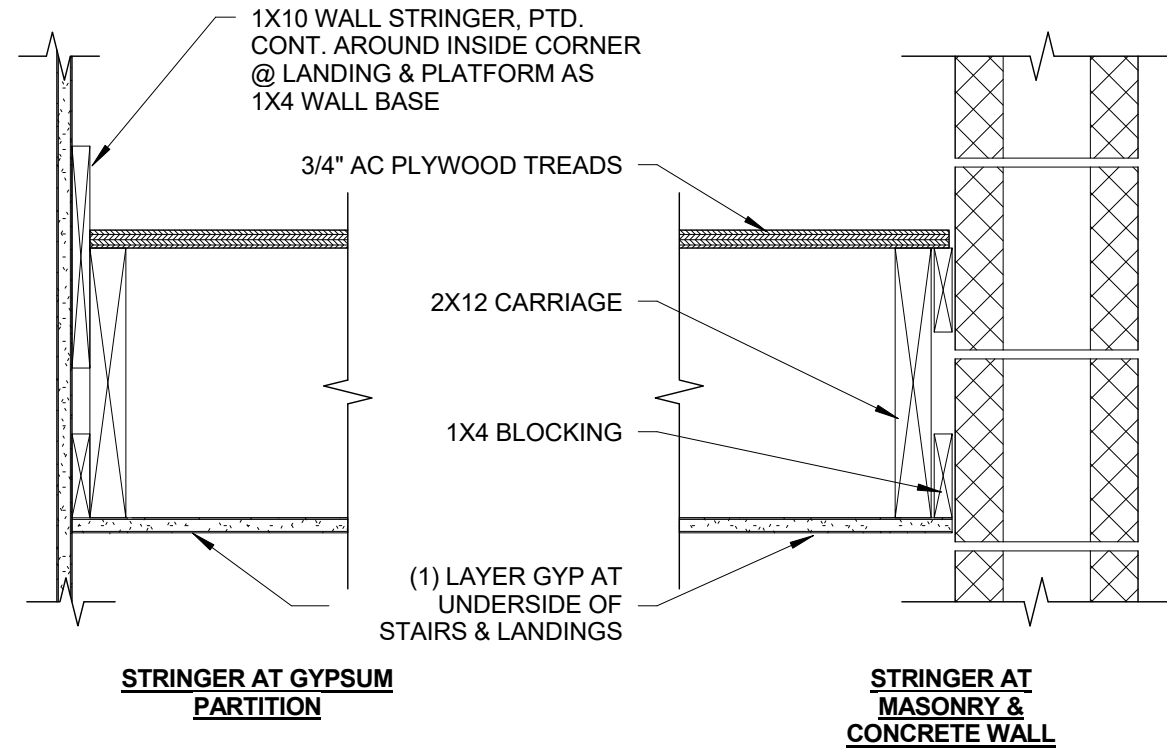

11 STAIR DETAIL - STRINGER DETAIL  
1 1/2" = 1'-0"

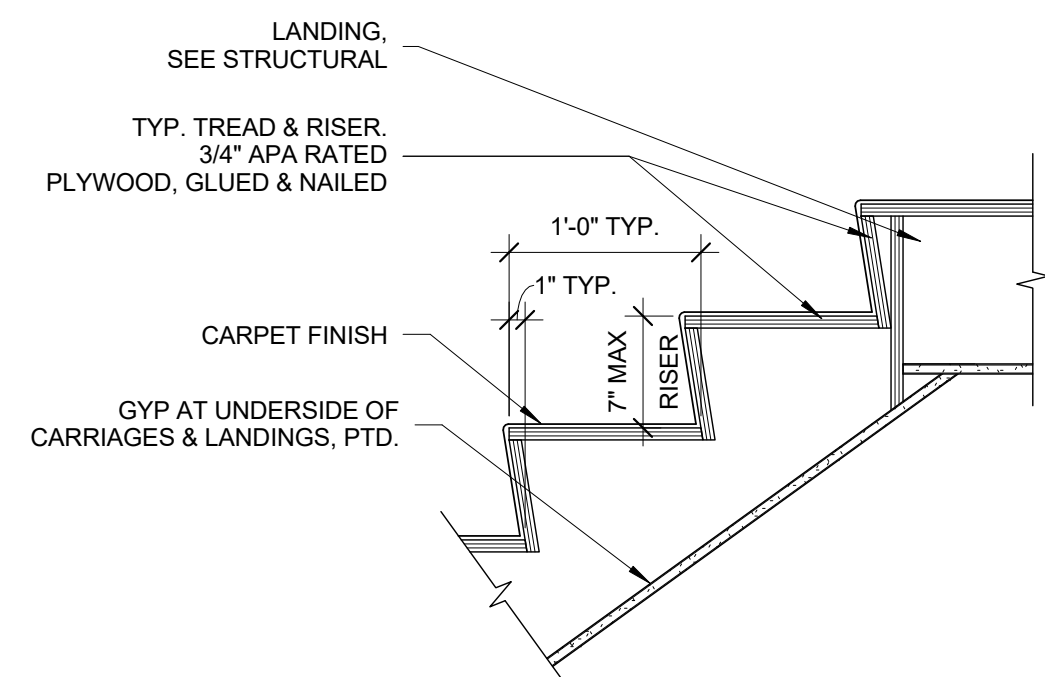

10 STAIR DETAIL - LANDING DETAIL  
1" = 1'-0"

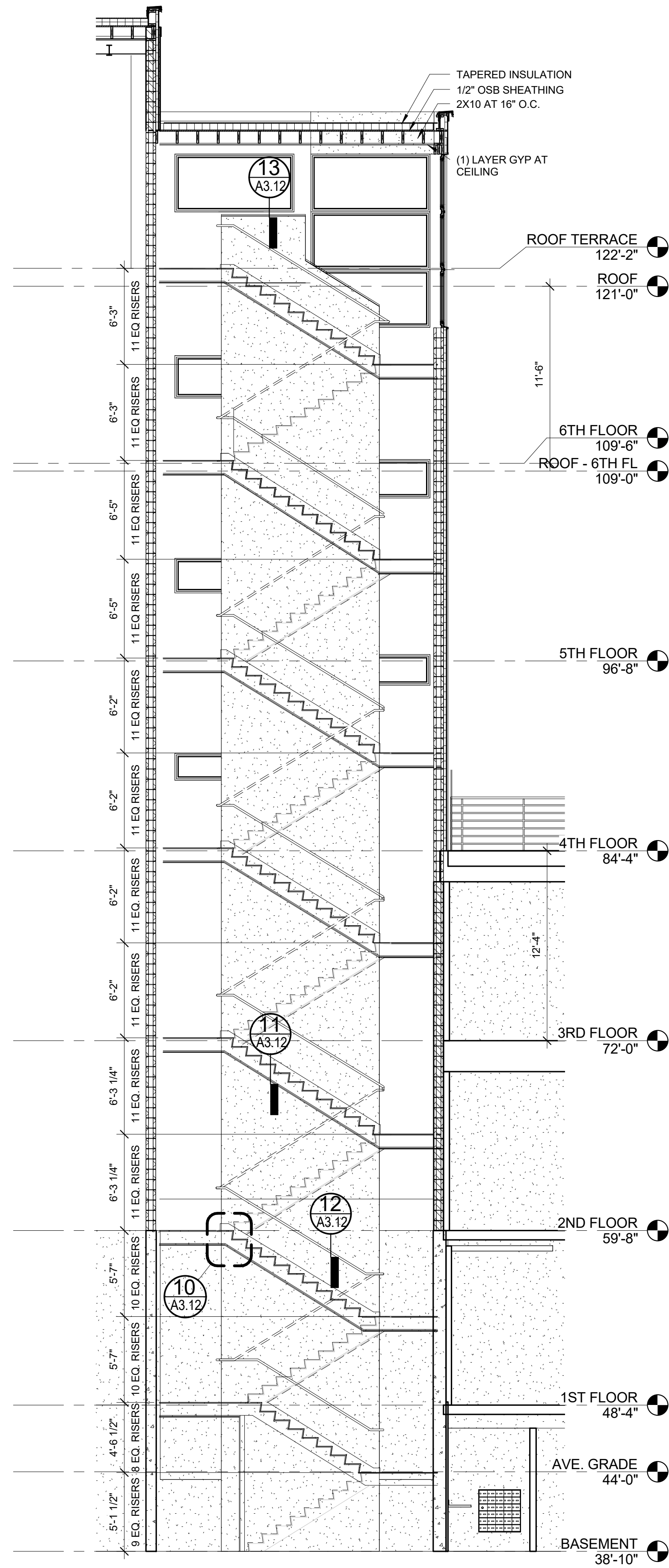

9 STAIR SECTION  
3/16" = 1'-0"

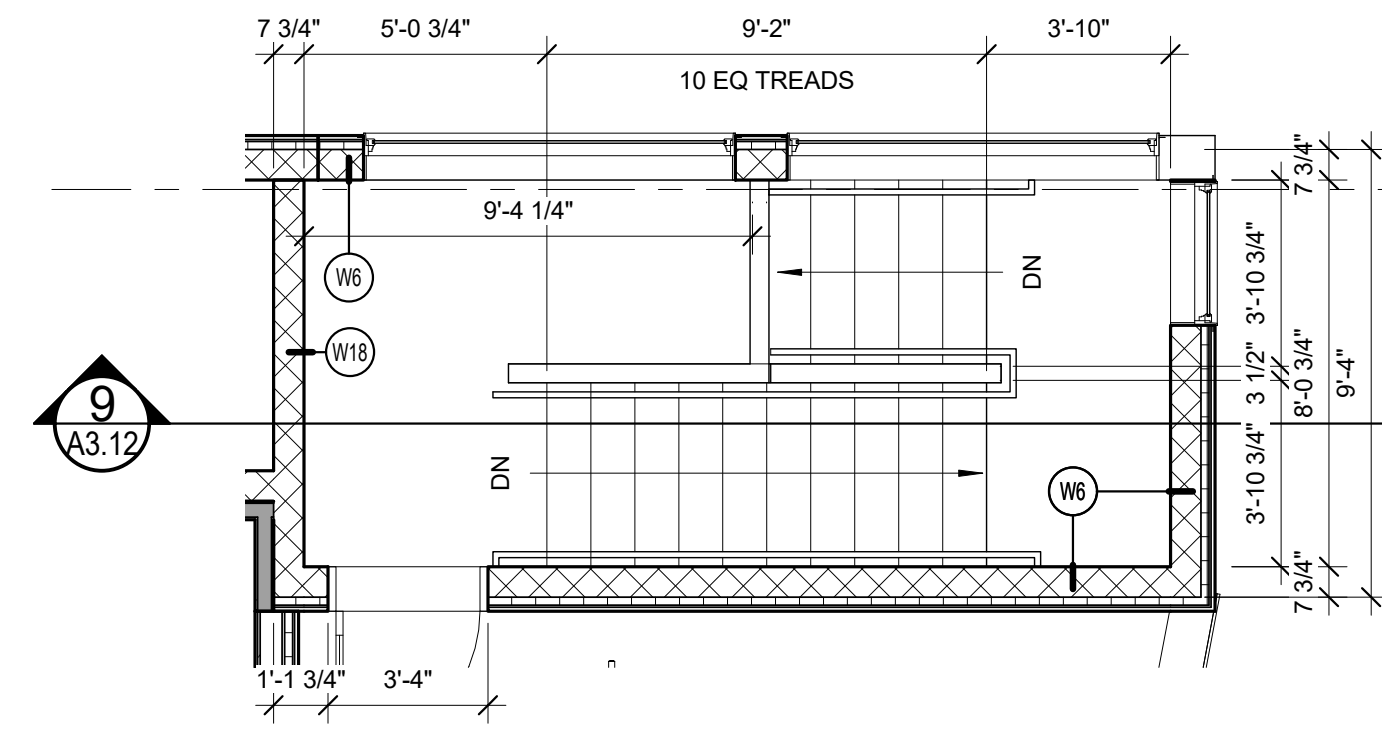

8 STAIR A - ROOF DECK  
1/4" = 1'-0"

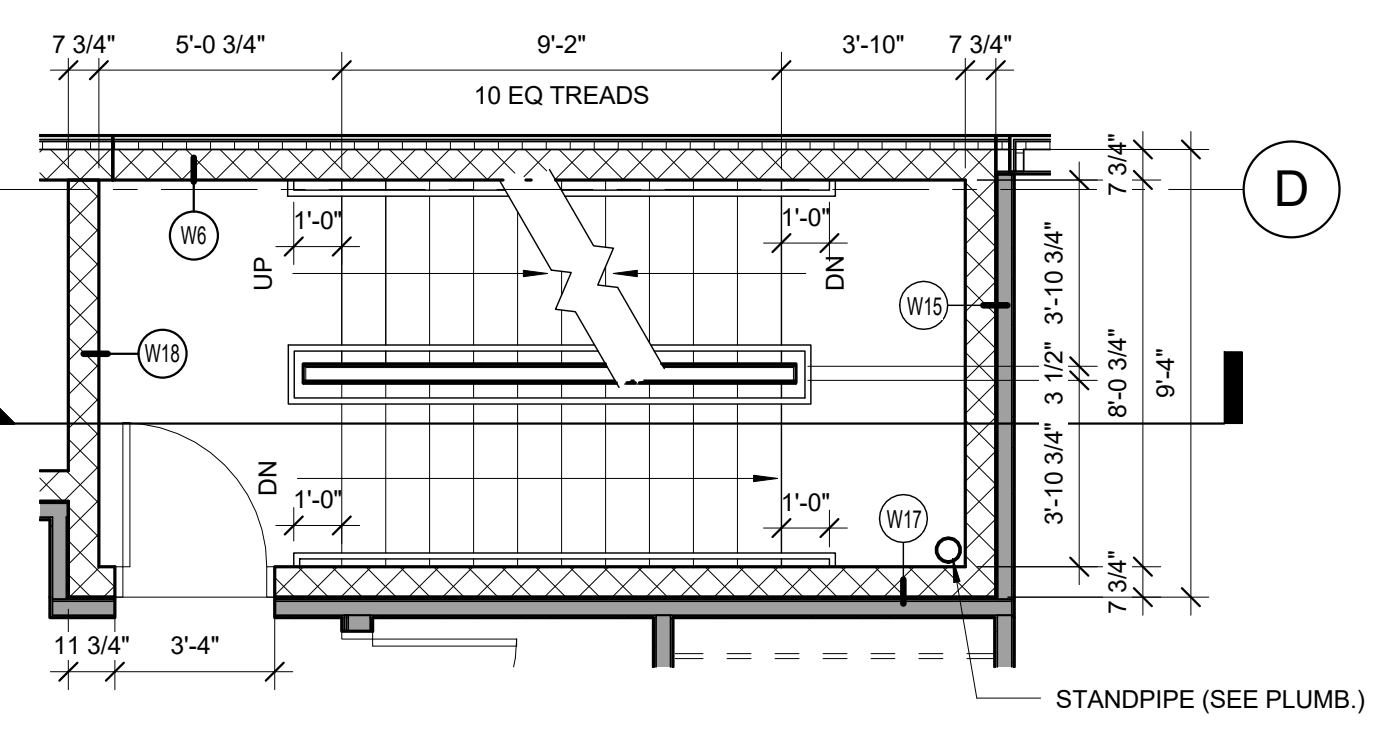

4 STAIR A - 3RD FLOOR  
1/4" = 1'-0"

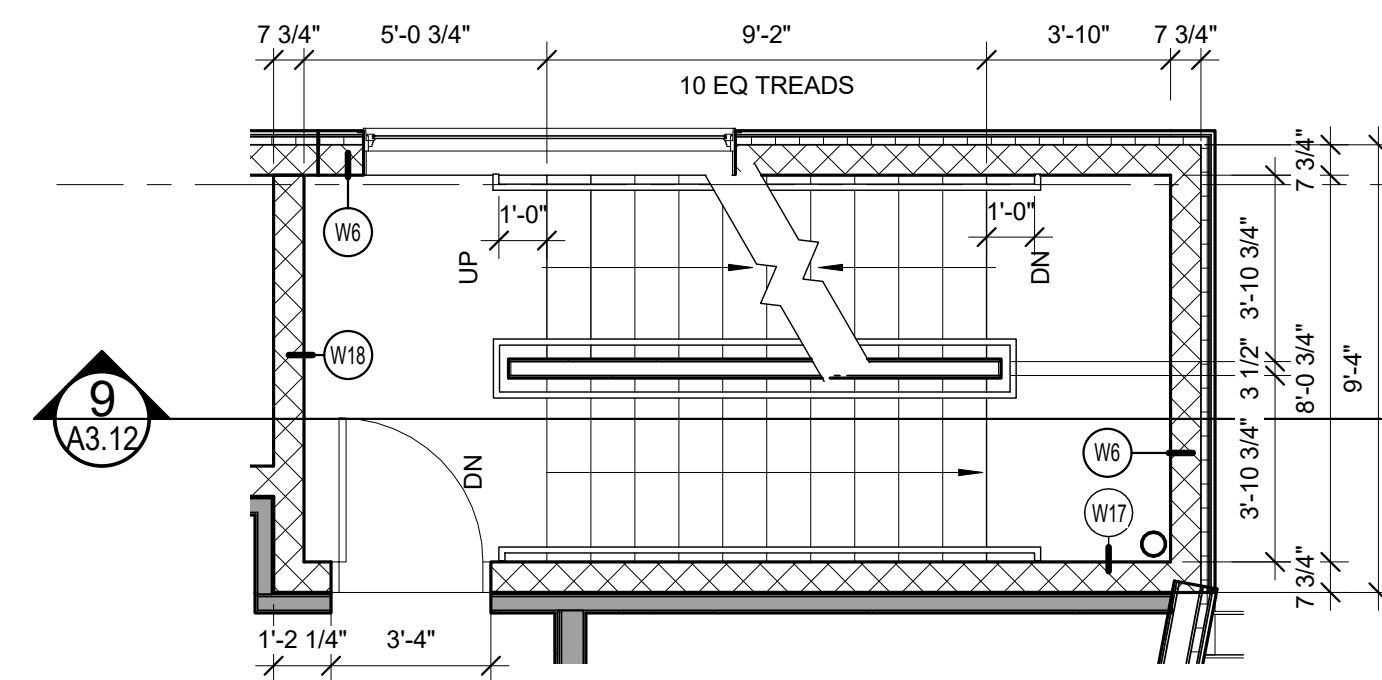

7 STAIR A - 6TH FLOOR  
1/4" = 1'-0"

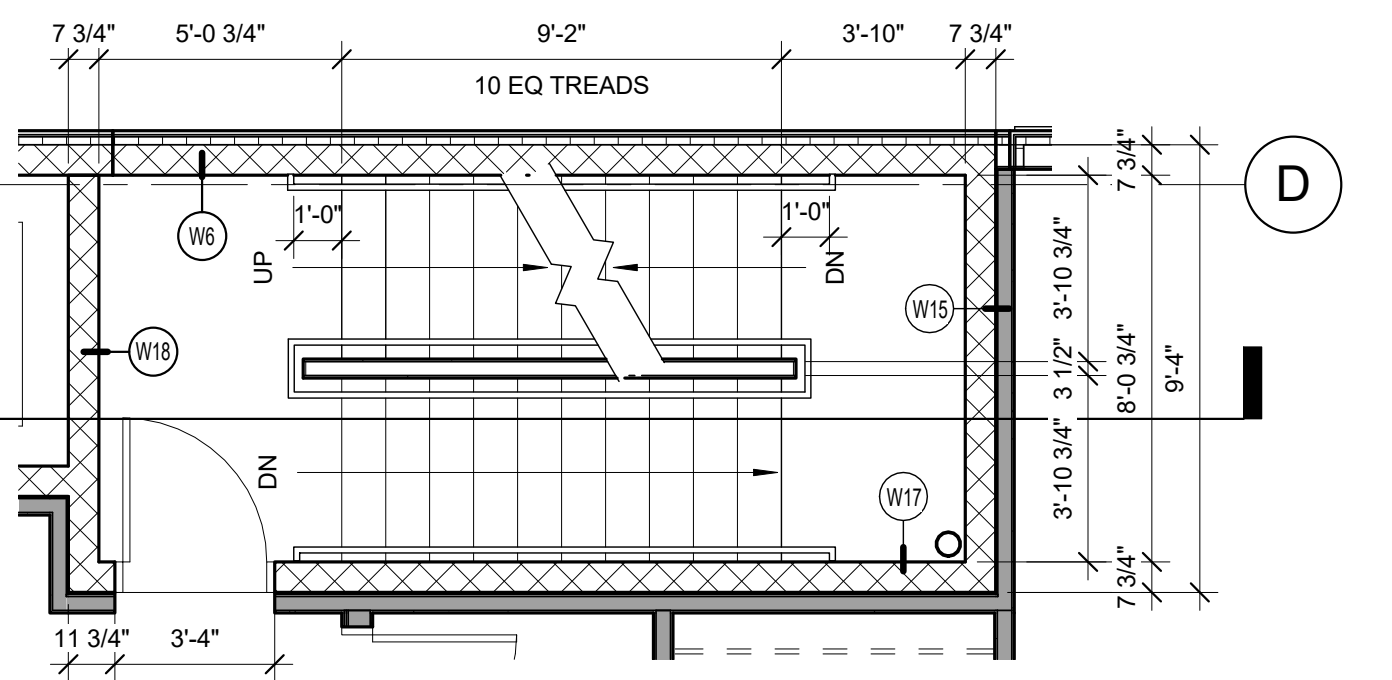

3 STAIR A - 2ND FLOOR  
1/4" = 1'-0"

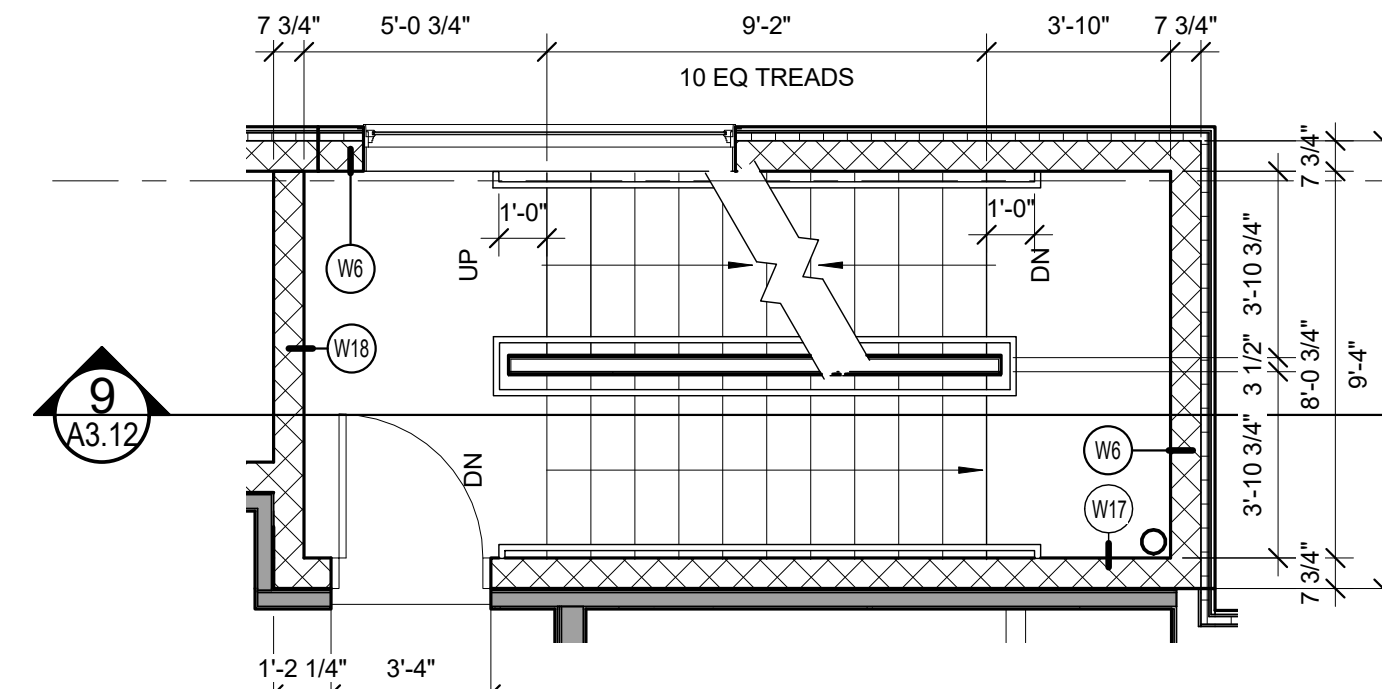

6 STAIR A - 5TH FLOOR  
1/4" = 1'-0"

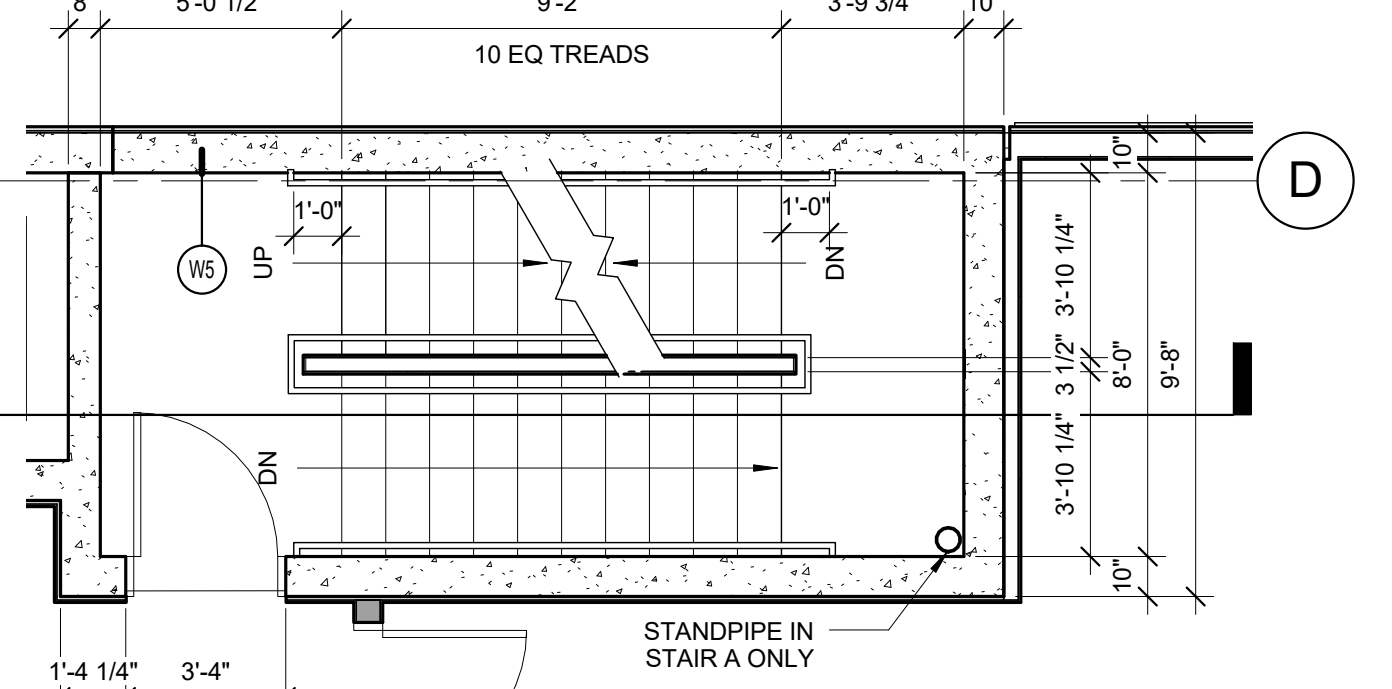

2 STAIR A - 1ST FLOOR  
1/4" = 1'-0"

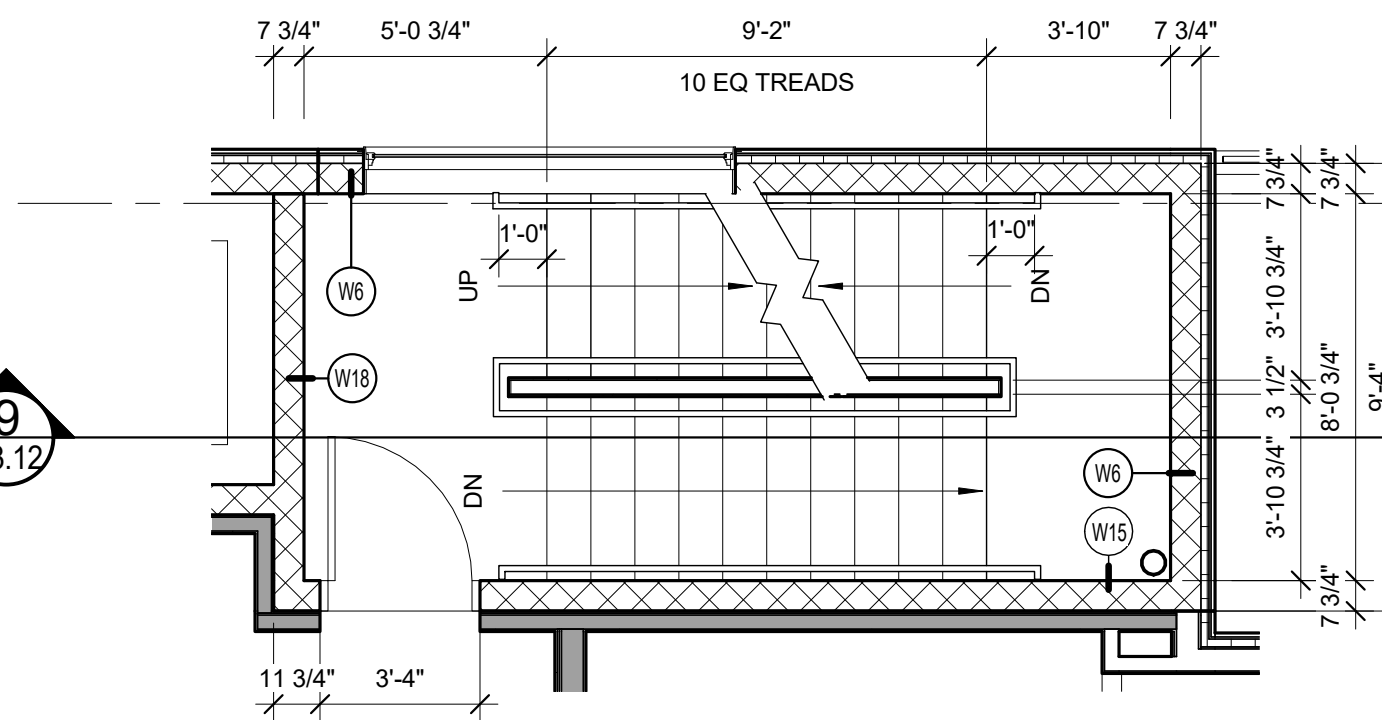

5 STAIR A - 4TH FLOOR  
1/4" = 1'-0"

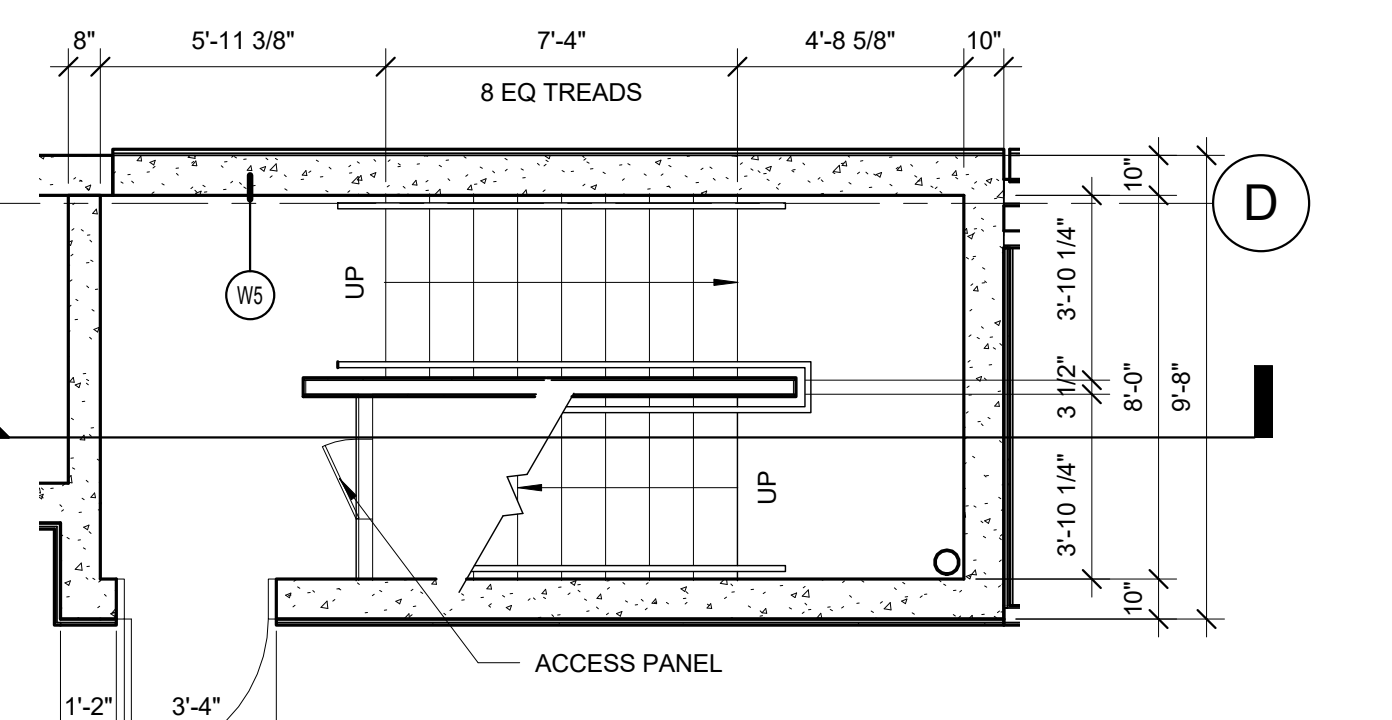

1 STAIR A - BASEMENT  
1/4" = 1'-0"