

1
S2.2
CASTING TYPES 1a and 1b
ELEVATION OF BOTTOM RAIL TAB CASTING
3" = 1'-0" (ON 22 X 34 SHEET)

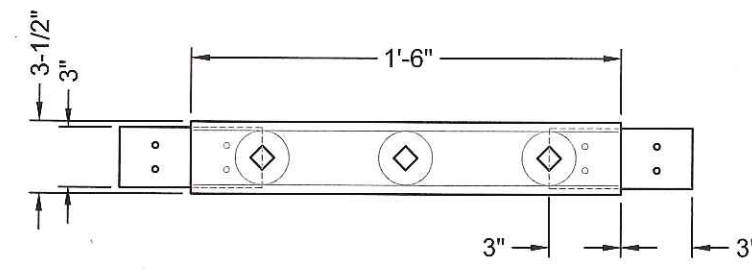

4
S2.2
CASTING TYPE 2
TOP VIEW OF BOTTOM RAIL CASTING
3" = 1'-0" (ON 22 X 34 SHEET)

DIMENSIONS AND SHAPES ARE PROVIDED FOR PRICING PURPOSES ONLY. EACH NEW CASTING TYPE SHALL BE REPLICATED BY CREATING A MOLD FROM AN IN SITU, GOOD CONDITION EXAMPLE. PROPER ALLOWANCES SHALL BE PROVIDED IN MOLDS FOR ANTICIPATED SHRINKAGE OF IRON AS IT COOLS. EACH FINAL CASTING SHALL MATCH ORIGINAL IN DIMENSION, SHAPE, PROFILE AND TEXTURE AND BE ATTACHED AS PRESCRIBED.

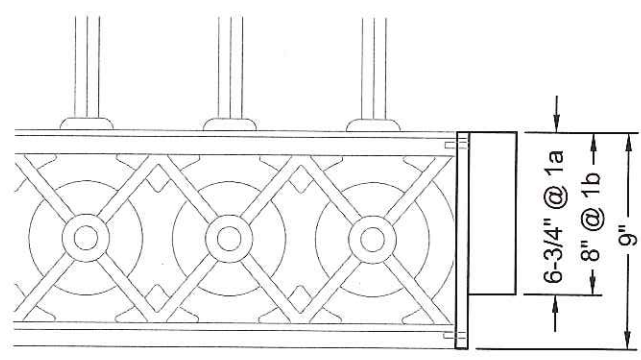

2
S2.2
CASTING TYPES 1a and 1b
ELEVATION OF BOTTOM RAIL TAB CASTING
3" = 1'-0" (ON 22 X 34 SHEET)

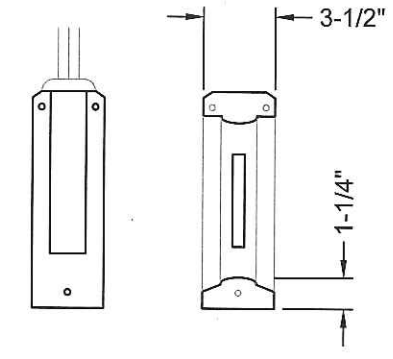

3
S2.2
CASTING TYPES 1a and 1b
SIDES OF TAB CASTING
3" = 1'-0" (ON 22 X 34 SHEET)

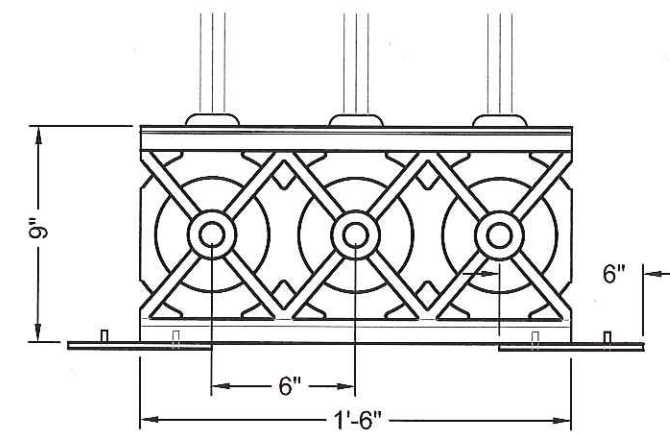

5
S2.2
CASTING TYPE 2
ELEVATION OF ORNAMENTAL BOTTOM RAIL CASTING
3" = 1'-0" (ON 22 X 34 SHEET)

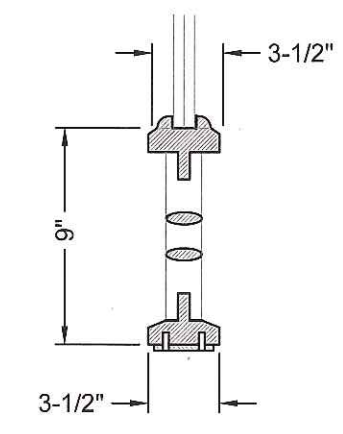

6
S2.2
CASTING TYPE 2
SECTION OF BOTTOM RAIL CASTING
3" = 1'-0" (ON 22 X 34 SHEET)

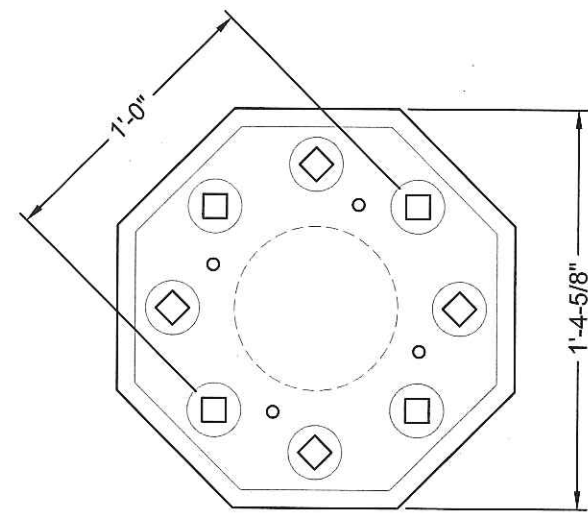

7
S2.2
CASTING TYPE 3
TOP VIEW OF FENCE POST BASE CASTING
3" = 1'-0" (ON 22 X 34 SHEET)

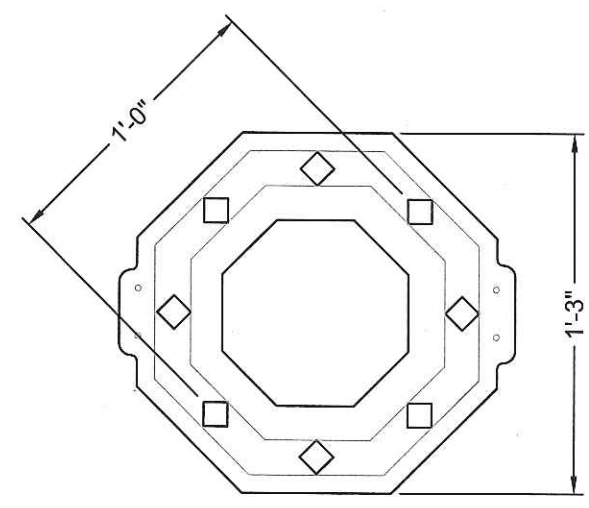

9
S2.2
CASTING TYPE 4
TOP VIEW OF FENCE POST BASE CASTING
3" = 1'-0" (ON 22 X 34 SHEET)

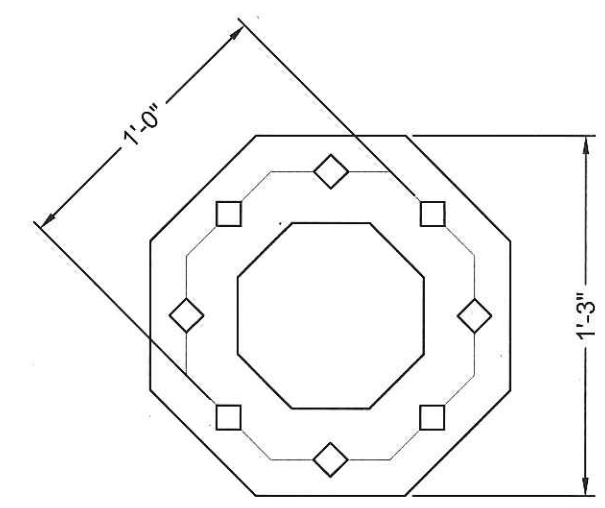

11
S2.2
CASTING TYPE 5
TOP VIEW OF FENCE POST BASE CASTING
3" = 1'-0" (ON 22 X 34 SHEET)

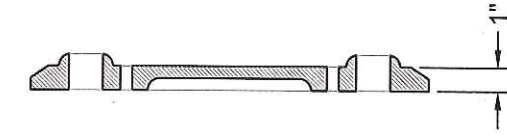

8
S2.2
CASTING TYPE 3
TOP VIEW OF FENCE POST BASE CASTING
3" = 1'-0" (ON 22 X 34 SHEET)

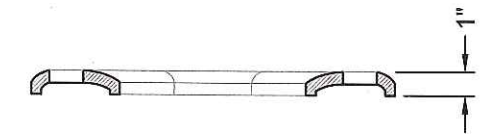

10
S2.2
CASTING TYPE 4
TOP VIEW OF FENCE POST BASE CASTING
3" = 1'-0" (ON 22 X 34 SHEET)

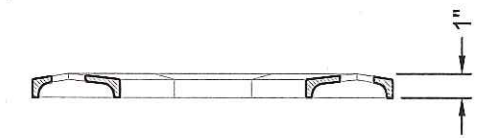

12
S2.2
CASTING TYPE 5
TOP VIEW OF FENCE POST BASE CASTING
3" = 1'-0" (ON 22 X 34 SHEET)

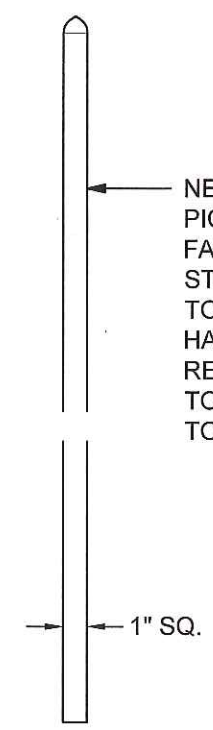

13
S2.2
MILD STEEL SHAPE TYPE 6
ELEV. OF FENCE POST PICKET
3" = 1'-0" (ON 22 X 34 SHEET)

NEW PICKETS AND NEW PICKET SECTIONS TO BE FABRICATED FROM MILD STEEL BAR STOCK. FINIAL TOPS TO BE SHAPED BY HAND. NEW PICKET REPLACEMENT SECTIONS TO BE GENTLY WELDED TO EXISTING CAST IRON.

NOT FOR CONSTRUCTION

RESURGENCE
ENGINEERING & PRESERVATION, INC.
132 BRENTWOOD STREET
PORTLAND, ME 04103
207.773.4880

LINCOLN PARK IRON FENCE RESTORATION
TYPICAL NEW IRON CASTING DETAILS

Project # 17-019
Date: 1/29/18
Issued for:
HP REVIEW

REVISIONS	
NO.	DATE
△	MM-DD-YY
△	MM-DD-YY

SHEET
S-2.2