

DISPLAY THIS CARD ON PRINCIPAL FRONTAGE OF WORK



# CITY OF PORTLAND

# BUILDING PERMIT

This is to certify that EASTERN FIRE SERVICES  
of P.O. Box 1390, Auburn, ME 04210

For installation at 1 MONUMENT WAY  
One Monument Way

Job ID: 2011-07-1611-FAFS

CBL: 027 - - F - 011 - 001 - - - -

has permission to renovate an existing fire alarm system and install an AES master box provided that the person or persons, firm or corporation accepting this permit shall comply with all of the provisions of the Statutes of Maine and of the Ordinances of the City of Portland regulating the construction, maintenance and use of the buildings and structures, and of the application on file in the department.

Notification of inspection and written permission procured before this building or part thereof is lathed or otherwise closed-in. 48 HOUR NOTICE IS REQUIRED.

A final inspection must be completed by owner before this building or part thereof is occupied. If a certificate of occupancy is required, it must be

*Bjankov* (58)  
Fire Prevention Officer

Code Enforcement Officer / Plan Reviewer

**THIS CARD MUST BE POSTED ON THE STREET SIDE OF THE PROPERTY  
PENALTY FOR REMOVING THIS CARD**

## BUILDING PERMIT INSPECTION PROCEDURES

Please call 874-8703 or 874-8693 (ONLY)

or email: [buildinginspections@portlandmaine.gov](mailto:buildinginspections@portlandmaine.gov)

With the issuance of this permit, the owner, builder or their designee is required to provide adequate notice to the city of Portland Inspections Services for the following inspections. Appointments must be requested 48 to 72 hours in advance of the required inspection. The inspection date will need to be confirmed by this office.

- **Please read the conditions of approval that is attached to this permit!! Contact this office if you have any questions.**
- **Permits expire in 6 months. If the project is not started or ceases for 6 months.**
- **If the inspection requirements are not followed as stated below additional fees may be incurred due to the issuance of a "Stop Work Order" and subsequent release to continue.**

The project cannot move to the next phase prior to the required inspection and approval to continue, REGARDLESS OF THE NOTICE OF CIRCUMSTANCES.

IF THE PERMIT REQUIRES A CERTIFICATE OF OCCUPANCY, IT MUST BE PAID FOR AND ISSUED TO THE OWNER OR DESIGNEE BEFORE THE SPACE MAY BE OCCUPIED.



# PORTLAND MAINE

*Strengthening a Remarkable City, Building a Community for Life* • [www.portlandmaine.gov](http://www.portlandmaine.gov)

Director of Planning and Urban Development  
Penny St. Louis

Job ID: 2011-07-1611-FAFS  
Renovation of an existing fire alarm  
system & addition of AES master box

For installation at:  
1 MONUMENT WAY  
One Monument Way

CBL: 027 - - F - 011 - 001 - - - -

## Conditions of Approval:

### **Fire**

The fire alarm system shall comply with the City of Portland Standard for Signaling Systems for the Protection of Life and Property. All fire alarm installation and servicing companies shall have a Certificate of Fitness from the Fire Department.

In field installation shall be installed per code as conditions dictate.

Records cabinet, FACP, annunciator(s), and pull stations shall be keyed alike.

Central Station monitoring for addressable fire alarm systems shall be by point.

All fire alarm records required by NFPA 72 should be stored in an approved cabinet located at the FACP labeled "FIRE ALARM RECORDS".

Installation of a Fire Alarm system requires a Knox Box to be installed per city ordinance.

System acceptance and commissioning must be coordinated with alarm and suppression system contractors and the Fire Department. Call 874-8703 to schedule.

Fire Alarm system shall be maintained. If system is to be off line over 4 hours a fire watch shall be in place. Dispatch notification required 874-8576.

Fire alarm system requires a wireless master box connection per city ordinance. Masterbox design and installation shall be as approved by City Electrical Division.

AES Master box zones shall be attached to conditions. City disconnect shall be by zone.

## Master Box Approval

Applicant: Paragon Management  
App Phone #: 207-221-2359  
Building Name: One Monument Way  
Building Address: 1 Monument Way  
Occupancy: Mercantile mall  
Assembly OL>300, 20 unit apartment building, etc.

Emergency Contact: Same  
Emergency phone #: 207-415-3829  
Date of Application: 7/11/11  
Billing Address: PO Box 17536  
Portland, ME 04112  
Comments:

### Applicant completes red box and submits with Fire Alarm Permit

1

FIRE PREVENTION:

Approved

Denied

7 / 11 / 11  
Date

B. Wallace  
Fire Prevention Officer

Zone 1: Water flow

Zone 2: City disconnect

Zone 3: Pulls stations and detectors

Zone 4: Unassigned

Zone 5: Unassigned

Zone 6: Unassigned

Zone 7: Unassigned

Zone 8: AES Tamper switch

Modify City Box response to alarm sounding in CAD:  YES  NO

2

FIRE ALARM:

Box #: \_\_\_\_\_

ELECTRICAL DIVISION:  Approved

Denied

Box Type: AES Radio Box / \_\_\_\_\_  
New Other

3

Test Date: \_\_\_\_ / \_\_\_\_ / \_\_\_\_ In Service Date: \_\_\_\_ / \_\_\_\_ / \_\_\_\_

\_\_\_\_\_  
Fire Alarm Technician

AES

Circuit if applicable: \_\_\_\_\_

4

FIRE ALARM: Same Running Assignment As Box: \_\_\_\_\_

Notifications:  All Stations  Run Books  Digitizer  Computer  Cad Box Test

South Portland

\_\_\_\_\_  
Other

\_\_\_\_\_  
Dispatcher

5

BILLING:  Entered

\_\_\_\_\_  
Financial Officer

**City of Portland, Maine - Building or Use Permit Application**

389 Congress Street, 04101 Tel: (207) 874-8703, FAX: (207) 8716

Job No: 2011-07-1611-FAFS	Date Applied: 7/1/2011	CBL: 027 - - F - 011 - 001 - - - - -	
Location of Construction: 1 MONUMENT WAY	Owner Name: ONE MONUMENT WAY LLC	Owner Address: ONE MONUMENT WAY PORTLAND, ME - MAINE 04101	Phone:
Business Name:	Contractor Name: Eastern Fire Protection Co., Inc,	Contractor Address: P.O Box 1390 AUBURN MAINE 04211	Phone:  (207) 784-1507
Lessee/Buyer's Name:	Phone:	Permit Type: FIRE ALARM - Fire Alarm	Zone: B-3
Past Use:  Mixed use with retail bakery on 1 <sup>st</sup> floor	Proposed Use:  Same: Mixed use with retail bakery on 1 <sup>st</sup> floor – to install fire alarm	Cost of Work: \$20,000.00	CEO District:
		Fire Dept:  <input checked="" type="checkbox"/> Approved w/ conditions <input type="checkbox"/> Denied <input type="checkbox"/> N/A	Inspection: Use Group: Type:
		Signature: <i>Byawes</i>	Signature:
Proposed Project Description: Install Fire Alarm		Pedestrian Activities District (P.A.D.)	
Permit Taken By: Lannie		<b>Zoning Approval</b>	

Special Zone or Reviews	Zoning Appeal	Historic Preservation
<input type="checkbox"/> Shoreland	<input type="checkbox"/> Variance	<input type="checkbox"/> Not in Dist or Landmark
<input type="checkbox"/> Wetlands	<input type="checkbox"/> Miscellaneous	<input type="checkbox"/> Does not Require Review
<input type="checkbox"/> Flood Zone	<input type="checkbox"/> Conditional Use	<input type="checkbox"/> Requires Review
<input type="checkbox"/> Subdivision	<input type="checkbox"/> Interpretation	<input type="checkbox"/> Approved
<input type="checkbox"/> Site Plan	<input type="checkbox"/> Approved	<input type="checkbox"/> Approved w/Conditions
<input type="checkbox"/> Maj <input type="checkbox"/> Min <input type="checkbox"/> MM	<input type="checkbox"/> Denied	<input type="checkbox"/> Denied
Date: <i>OK</i> <i>7/1/11</i>	Date:	Date:

**CERTIFICATION**

I hereby certify that I am the owner of record of the named property, or that the proposed work is authorized by the owner of record and that I have been authorized by the owner to make this application as his authorized agent and I agree to conform to all applicable laws of this jurisdiction. In addition, if a permit for work described in the application is issued, I certify that the code official's authorized representative shall have the authority to enter all areas covered by such permit at any reasonable hour to enforce the provision of the code(s) applicable to such permit.

SIGNATURE OF APPLICANT ADDRESS DATE PHONE

RESPONSIBLE PERSON IN CHARGE OF WORK, TITLE DATE PHON

201-07-1611



# Fire Alarm Permit

If you or the property owner owes real estate or property taxes or user charges on any property within the city, payment arrangements must be made before permits of any kind are accepted.

7511

Installation address: One Monument Way CBL: 27-F-11

Exact location: (within structure) throughout

Type of occupancy(s) (NFPA & ICC): Mercantile / Business

Building owner: Paragon Management B-3

System Designer (point of contact): John Kempton Nicet III

Designer phone: 784-1507 E-mail: jkempton@teameastern.com

Installing contractor: Eastern Fire Services Certificate of Fitness No: M1024

Contractor phone: 784-1507 E-mail: \_\_\_\_\_

This is a new application: YES  NO  New AES Master Box: YES  NO   
(Include Master Box approval form)

Amendment to an existing permit: YES  NO  Permit no: \_\_\_\_\_

The following documents shall be provided with this application:

- Floor plans
- Wiring diagram
- Annunciator details
- Input/ Output Matrix
- Equipment data sheets
- Electrical Permit Pulled (check alarm/com)
- Scope of Work
- 11 1/2 x 17s
- pdf copy (may be e-mailed)
- Designer qualifications
- Battery/ voltage drop calcs

COST OF WORK: \$20,000.00

PERMIT FEE: \$220.00  
(\$10 PER \$1,000 + \$30 FOR THE FIRST \$1,000)

RECEIVED

- 1 2011

Dept. of Building Inspections  
City of Portland and Maine

Master box approval only: YES  NO   
(If yes check *New AES Master Box* above)

The designer shall be the responsible party for this application. Download a new copy of this application at [www.portlandmaine.gov/fire](http://www.portlandmaine.gov/fire) for every submittal. Submit all plans in electronic PDF in addition to readable 11 1/2 x 17s to the Building Inspections Department, 389 Congress Street, Room 315, Portland, Maine 04101.

Prior to acceptance of any fire alarm system, a complete commissioning and acceptance test must be coordinated with all fire system contractors and the Fire Department, and proper documentation of such test(s) provided.

All installation(s) must comply with the *City of Portland Technical Standard for Signaling Systems for the Protection of Life and Property*, available at [www.portlandmaine.gov/fire](http://www.portlandmaine.gov/fire).

Applicant signature: [Signature] Date: 6-28-11

# ELECTRICAL PERMIT

## City of Portland, Me.



To the Chief Electrical Inspector, Portland Maine:  
 The undersigned hereby applies for a permit to make electrical installations  
 in accordance with the laws of Maine, the City of Portland Electrical Ordinance,  
 National Electrical Code and the following specifications.

Date 07/11/11  
 Permit # \_\_\_\_\_  
 CBL# \_\_\_\_\_

LOCATION: One Monument Way METER MAKE & # \_\_\_\_\_  
 CMP ACCOUNT # \_\_\_\_\_ OWNER Paragon Management  
 TENANT \_\_\_\_\_ PHONE # 221-2359

**TOTAL EACH FEE**

OUTLETS	Receptacles	Switches	Smoke Detector	
				.20
FIXTURES	Incandescent	Fluorescent	Strips	.20
SERVICES	Overhead	Underground	TTL AMPS <800	15.00
	Overhead	Underground	>800	25.00
Temporary Service	Overhead	Underground	TTL AMPS	25.00
				25.00
METERS	(number of)			1.00
MOTORS	(number of)			2.00
RESID/COM	Electric units			1.00
HEATING	oil/gas units	Interior	Exterior	5.00
APPLIANCES	Ranges	Cook Tops	Wall Ovens	2.00
	Insta-Hot	Water heaters	Fans	2.00
	Dryers	Disposals	Dishwasher	2.00
	Compactors	Spa	Washing Machine	2.00
	Others (denote)			2.00
MISC. (number of)	Air Cond/win			3.00
	Air Cond/cent		Pools	10.00
	HVAC	EMS	Thermostat	5.00
	Signs			10.00
	Alarms/res			5.00
	Alarms/com			15.00
	Heavy Duty(CRKT)			2.00
	Circus/Carnv			25.00
	Alterations			5.00
	Fire Repairs			15.00
	E Lights			1.00
	E Generators			20.00
PANELS	Service	Remote	Main	4.00
TRANSFORMER	0-25 Kva			5.00
	25-200 Kva			8.00
	Over 200 Kva			10.00
			TOTAL AMOUNT DUE	
	MINIMUM FEE/COMMERCIAL <u>55.00</u>		MINIMUM FEE	45.00

**RECEIVED**

JUL - 1 - 2011

Dept. of Building Inspection  
 City of Portland Maine

CONTRACTORS NAME Eastern Fire Services MASTER LIC. # MS60016657  
 ADDRESS 170 Kittyhawk Ave, Auburn, Maine LIMITED LIC. # \_\_\_\_\_  
 TELEPHONE 784-1507

SIGNATURE OF CONTRACTOR Paul [Signature]





# Siemens FS-250 Battery Calculations

Job Name: One Monument Way

Date: 6/28/2011

	<b>STANDBY</b>	<b>ALARM</b>
<b>TOTAL SYSTEM CURRENT</b>	<b>0.304</b>	<b>4.559</b>

TOTAL FACP BATTERY CALCULATIONS			
<b>TOTAL STANDBY CURRENT</b>	A/H REQ'D		A/H STANDBY
0.304 Amps X	24	HRS.	<b>7.291</b>
<b>TOTAL ALARM CURRENT</b>	A/H REQ'D		A/H ALARM
4.559 Amps X	5	MIN.	<b>0.475</b>

<b>Required Battery Capacity</b>	<b>7.766</b>
----------------------------------	--------------

Always use a battery with higher AH rating than required.

**BATTERY SUPPLIED: 2x12 AH**

**NAC Circuit Voltage Drop Calculation**

Project Name	One Monument Way		
Date	6/28/2011		
Circuit Number	NAC#1		
Area Covered	Basement		
NAC Source Alarm Voltage	20.4	Wire Gauge	Resistance
Minimum Device Voltage	16	14	Per MFt Cable
Distance to first appliance	20		5.84
Total Circuit Current	0.674		

Wire Gauge for balance of circuit	14	5.84
-----------------------------------	----	------

	Device Current	Distance from previous device	Voltage at Device	Drop from source	Percent Drop
Appliance 1	0.078		20.32	0.08	0.4%
Appliance 2	0.064	20	20.25	0.15	0.7%
Appliance 3	0.064	20	20.19	0.21	1.0%
Appliance 4	0.078	20	20.13	0.27	1.3%
Appliance 5	0.078	30	20.07	0.33	1.6%
Appliance 6	0.078	60	19.96	0.44	2.2%
Appliance 7	0.078	20	19.93	0.47	2.3%
Appliance 8	0.078	30	19.90	0.50	2.4%
Appliance 9	0.078	30	19.89	0.51	2.5%
END	0.000	0	19.89	0.51	2.5%
END	0.000	0	19.89	0.51	2.5%
END	0.000	0	19.89	0.51	2.5%
END	0.000	0	19.89	0.51	2.5%
END	0.000	0	19.89	0.51	2.5%
END	0.000	0	19.89	0.51	2.5%
END	0.000	0	19.89	0.51	2.5%
END	0.000	0	19.89	0.51	2.5%
END	0.000	0	19.89	0.51	2.5%
END	0.000	0	19.89	0.51	2.5%
END	0.000	0	19.89	0.51	2.5%
END	0.000	0	19.89	0.51	2.5%
END	0.000	0	19.89	0.51	2.5%
END	0.000	0	19.89	0.51	2.5%
END	0.000	0	19.89	0.51	2.5%
END	0.000	0	19.89	0.51	2.5%
Totals	0.674	250			

Appliance circuit voltage drop calculations start at "end of battery life" as NAC Source Alarm Voltage and use 20% below nameplate rating for Minimum Appliance Voltage.

Note. Wire resistance is based on the 1996 NEC Table 8 Uncoated DC resistance. Solid conductors except gauges 10 and 12 which are for stranded.

## NAC Circuit Voltage Drop Calculation

Project Name	One Monument Way		
Date	6/28/2011		
Circuit Number	NAC#2		
Area Covered	First Floor		
NAC Source Alarm Voltage	20.4	Wire Gauge	Resistance Per MFt Cable
Minimum Device Voltage	16		
Distance to first appliance	60		
Total Circuit Current	0.936	14	5.84

Wire Gauge for balance of circuit	14	5.84
-----------------------------------	----	------

Circuit is within limits	Device Current	Distance from previous device	Voltage at Device	Drop from source	Percent Drop
Appliance 1	0.078		20.07	0.33	1.6%
Appliance 2	0.078	20	19.97	0.43	2.1%
Appliance 3	0.078	30	19.84	0.56	2.8%
Appliance 4	0.078	30	19.71	0.69	3.4%
Appliance 5	0.078	20	19.64	0.76	3.7%
Appliance 6	0.078	30	19.54	0.86	4.2%
Appliance 7	0.078	40	19.43	0.97	4.7%
Appliance 8	0.078	60	19.30	1.10	5.4%
Appliance 9	0.078	20	19.26	1.14	5.6%
Appliance 10	0.078	20	19.23	1.17	5.7%
Appliance 11	0.078	60	19.18	1.22	6.0%
Appliance 12	0.078	20	19.17	1.23	6.0%
END	0.000	0	19.17	1.23	6.0%
END	0.000	0	19.17	1.23	6.0%
END	0.000	0	19.17	1.23	6.0%
END	0.000	0	19.17	1.23	6.0%
END	0.000	0	19.17	1.23	6.0%
END	0.000	0	19.17	1.23	6.0%
END	0.000	0	19.17	1.23	6.0%
END	0.000	0	19.17	1.23	6.0%
END	0.000	0	19.17	1.23	6.0%
END	0.000	0	19.17	1.23	6.0%
END	0.000	0	19.17	1.23	6.0%
END	0.000	0	19.17	1.23	6.0%
END	0.000	0	19.17	1.23	6.0%
END	0.000	0	19.17	1.23	6.0%
END	0.000	0	19.17	1.23	6.0%
Totals	0.936	410			

Appliance circuit voltage drop calculations start at "end of battery life" as NAC Source Alarm Voltage and use 20% below nameplate rating for Minimum Appliance Voltage.

Note. Wire resistance is based on the 1996 NEC Table 8 Uncoated DC resistance. Solid conductors except gauges 10 and 12 which are for stranded.

## NAC Circuit Voltage Drop Calculation

Project Name	One Monument Way		
Date	6/28/2011		
Circuit Number	NAC#3		
Area Covered	Second Floor		
NAC Source Alarm Voltage	20.4	Wire Gauge	Resistance
Minimum Device Voltage	16	14	Per MFt Cable
Distance to first appliance	70		5.84
Total Circuit Current	1.520		

Wire Gauge for balance of circuit	14	5.84
-----------------------------------	----	------

Circuit is within limits	Device Current	Distance from previous device	Voltage at Device	Drop from source	Percent Drop
Appliance 1	0.078		19.78	0.62	3.0%
Appliance 2	0.078	40	19.44	0.96	4.7%
Appliance 3	0.064	20	19.28	1.12	5.5%
Appliance 4	0.078	50	18.90	1.50	7.3%
Appliance 5	0.064	20	18.76	1.64	8.0%
Appliance 6	0.064	20	18.62	1.78	8.7%
Appliance 7	0.064	30	18.43	1.97	9.6%
Appliance 8	0.064	30	18.25	2.15	10.5%
Appliance 9	0.064	20	18.14	2.26	11.1%
Appliance 10	0.064	20	18.03	2.37	11.6%
Appliance 11	0.078	20	17.94	2.46	12.1%
Appliance 12	0.078	20	17.85	2.55	12.5%
Appliance 13	0.078	40	17.69	2.71	13.3%
Appliance 14	0.064	40	17.55	2.85	14.0%
Appliance 15	0.078	20	17.48	2.92	14.3%
Appliance 16	0.064	40	17.38	3.02	14.8%
Appliance 17	0.064	30	17.31	3.09	15.2%
Appliance 18	0.064	20	17.27	3.13	15.4%
Appliance 19	0.078	20	17.24	3.16	15.5%
Appliance 20	0.064	30	17.20	3.20	15.7%
Appliance 21	0.064	20	17.19	3.21	15.7%
Appliance 22	0.064	20	17.18	3.22	15.8%
END	0.000	0	17.18	3.22	15.8%
END	0.000	0	17.18	3.22	15.8%
END	0.000	0	17.18	3.22	15.8%
Totals	1.520	640			

Appliance circuit voltage drop calculations start at "end of battery life" as NAC Source Alarm Voltage and use 20% below nameplate rating for Minimum Appliance Voltage.

Note. Wire resistance is based on the 1996 NEC Table 8 Uncoated DC resistance. Solid conductors except gauges 10 and 12 which are for stranded.

## NAC Circuit Voltage Drop Calculation

Project Name	<b>One Monument Way</b>		
Date	<b>6/28/2011</b>		
Circuit Number	<b>NAC#4</b>		
Area Covered	<b>Third &amp; Fourth Floors</b>		
NAC Source Alarm Voltage	20.4	Wire Gauge	Resistance Per MFt Cable
Minimum Device Voltage	16		
Distance to first appliance	90		
Total Circuit Current	1.186	14	5.84

Wire Gauge for balance of circuit	14	5.84
-----------------------------------	----	------

Circuit is within limits	Device Current	Distance from previous device	Voltage at Device	Drop from source	Percent Drop
Appliance 1	0.078		19.78	0.62	3.1%
Appliance 2	0.064	40	19.52	0.88	4.3%
Appliance 3	0.064	20	19.40	1.00	4.9%
Appliance 4	0.064	20	19.28	1.12	5.5%
Appliance 5	0.078	20	19.17	1.23	6.0%
Appliance 6	0.064	30	19.03	1.37	6.7%
Appliance 7	0.064	20	18.94	1.46	7.2%
Appliance 8	0.064	20	18.85	1.55	7.6%
Appliance 9	0.064	20	18.78	1.62	7.9%
Appliance 10	0.078	30	18.68	1.72	8.4%
Appliance 11	0.078	30	18.59	1.81	8.9%
Appliance 12	0.064	50	18.46	1.94	9.5%
Appliance 13	0.064	20	18.42	1.98	9.7%
Appliance 14	0.064	20	18.39	2.01	9.9%
Appliance 15	0.078	20	18.36	2.04	10.0%
Appliance 16	0.078	20	18.34	2.06	10.1%
Appliance 17	0.078	40	18.32	2.08	10.2%
END	0.000	0	18.32	2.08	10.2%
END	0.000	0	18.32	2.08	10.2%
END	0.000	0	18.32	2.08	10.2%
END	0.000	0	18.32	2.08	10.2%
END	0.000	0	18.32	2.08	10.2%
END	0.000	0	18.32	2.08	10.2%
END	0.000	0	18.32	2.08	10.2%
END	0.000	0	18.32	2.08	10.2%
Totals	1.186	510			

Appliance circuit voltage drop calculations start at "end of battery life" as NAC Source Alarm Voltage and use 20% below nameplate rating for Minimum Appliance Voltage.

Note. Wire resistance is based on the 1996 NEC Table 8 Uncoated DC resistance. Solid conductors except gauges 10 and 12 which are for stranded.

# FireSeeker Fire Alarm System

## Addressable Fire Alarm Control Panel Model FS-250

### ARCHITECT AND ENGINEER SPECIFICATIONS

- One (1) Intelligent Signaling Line Circuit (Style 4 or Style 6)
- SLC loop supports up to 252 addressable Inputs and signal / relay outputs  
— 504 total inputs / outputs
- *SureWire™* polarity insensitive addressable-device loop wiring
- Devices operate on standard wire; no twist or shield required
- *FirePrint™* application-specific fire detection
- Four (4) Class B — Style Y / Two (2) Class A — Style Z notification-appliance circuits
- Up to 6 Amps. — NAC Power
- Built-in strobe synchronization protocol
- 80-character backlit LCD display
- One-man walk test (Silent or Audible)
- Auto Program Feature makes system commissioning more efficient
- Up to four (4) remote LCD displays with control capabilities
- Easily programmable from front keypad or Windows®-based PC configuration tool (not required)
- Maintenance and technician-level passwords for added security
- Optional internal DACT and city-tie module
- Up to 2,000-event history log
- Manual fan-restart feature

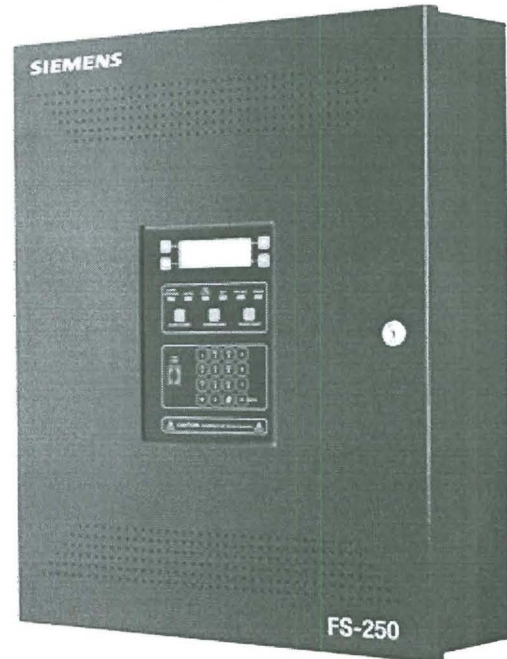

- Made in the USA, ISO 9001 quality crafted
- Three (3) on-board, programmable relays, plus one (1) non-programmable *Fail / Safe* relay for *Trouble* events
- ©UL 864 9th Edition Listed; FM, CSFM & NYMEA Approved

### Product Overview

The Model FS-250 Addressable Fire Alarm Control Panel is a low-cost, small panel suited for standalone operation in small-to-medium-sized facilities. Model FS-250 features a single, addressable input-device circuit and four (4) notification-appliance circuits. The Model FS-250 system is available in either a black or red enclosure, with operating controls and indicators behind a locked door. Model FS-250 is ©UL 864 9th Edition Listed by Underwriters Laboratories.

### Specifications

Model FS-250 indicates *Alarm*, *Trouble* and *Supervisory* conditions with an 80-character backlit LCD display and integral system status LEDs. *Acknowledge*;

*Alarm Silence* and *System Reset* commands are accomplished with built-in membrane control buttons. Basic user and maintenance-level functions, such as *Viewing History* or *System Enable / Disable*, are also accomplished through the membrane control buttons. Maintenance-level functions are password protected.

The main system for Model FS-250 can support up to 38 AH battery sets — up to 12 AH will fit inside the enclosure.

The basic Model FS-250 fire alarm control panel features a single, addressable signaling line circuit (Style 4 or 6); capable of supporting up to 252 addressable input devices — whether they are detectors, manual pull stations, or contact monitoring points.

FireSeeker Fire Alarm Control Panel (FS-250) **4306**

## Specifications — (continued)

Each detector can also have an optional, audible-detector base, relay-detector base or remote lamp. These auxiliary devices are completely controlled through logic, and are not required to activate simultaneously with the detector.

The Model FS-250 system also has four (4) Class B notification-appliance circuits built into the main board, which can be configured as two (2) Class A circuits. Each circuit has a capacity of 1.5 amps of 24VDC for powering horns, strobes, chimes, and other notification appliances, and the total base-system capacity for the four (4) circuits is 3.0 amps — expandable to 6A max. Each NAC is fully programmable, and supports standard and custom-coded outputs of audible devices.

Model FS-250 control panel has three (3) programmable 'Form C' dry-contact relays. One (1) additional non-programmable 'Form C' dry-contact relay is provided that activates only on *Trouble* events — operating in *Fail / Safe* mode in order to activate if there is a system power failure. Each relay is rated at 1 amp @ 28VDC. Up to 0.5A auxiliary 24VDC power is also available on the Model FS-250 main board.

### Minimum Control Unit Configuration

#### Intelligent Signaling Line Circuit (SLC)

The main termination board for Model FS-250 has addressable-loop interface circuitry supporting one (1) SLC loop. Devices are polarity insensitive, and can operate on untwisted, unshielded wire.

#### Notification Appliance Circuits (NAC)

The Model FS-250 base panel has four (4) independent NACs. Each circuit can be configured to give continuous output, or one (1) of five (5) sounding patterns. NACs can be configured as: two (2) 'Class A — Style Z' or four (4) 'Class B — Style Y.'

#### Dry Contacts

Three (3) programmable 'Form C' dry-contact relays are provided on the Model FS-250 fire alarm control panel. One (1) additional 'Form C' dry-contact relay is provided that activates only on *Trouble* events. This relay operates in *Fail / Safe* mode, in order to activate if there is a power failure of the Model FS-250 system.

#### Power Supply

This component provides all operating power to the Model FS-250 panel for *Standby* and *Alarm* conditions.

### Optional Control Unit Configuration

#### Digital-Alarm Communication Transmitter (FS-DACT)

Communication between the FS-250 fire alarm control panel and a monitoring station is accomplished with Model FS-DACT, which supports two (2) lines and two (2) accounts, and can transmit serial data, by point, to the central or remote station.

Communication protocols available include:

- SIA DCS 8
- SIA DCS 20
- Ademco Contact ID
- 3/1 1400 Hz
- 3/1 2300 Hz
- 4/2 1400 Hz
- 4/2 2300 Hz

Model FS-DACT mounts within the Model FS-250 fire alarm control panel. Neither an external enclosure nor wires are required between the panel and the dialer. Programming of account and dialing data is done as part of the system configuration, and no external programmer for the dialer is required.

#### Municipal Tie / Leased Line (FS-MT)

For installations that require connection to a municipal call box or a leased line, the municipal tie module (Model FS-MT) is used. Model FS-MT provides a local-energy output for municipal call-box connection, and gives a reverse-polarity output for lease-line connection. Model FS-MT mounts within the FS-250 enclosure. Model FS-MT parameters are programmed at the time of system configuration.

### Auxiliary Devices

Model FS-250 panel supports up to four (4) remote LCD displays and eight (8) serial annunciators or serial relay units.

#### Remote LCD Annunciator (FS-RD2)

Model FS-250 supports a remote LCD display — Model FS-RD2, which uses the same 80-character, backlit LCD display found on the main FS-250 fire alarm control panel. Model FS-RD2 has remote *Acknowledge*, *Alarm Silence*, and *System Reset* capability that is secured with a keyswitch. User-level functions are accessible from Model FS-RD2.

Model FS-RD2 communicates with Model FS-250's main system board, via a RS-485 communication network. Up to four (4) Model FS-RD2 remote displays can be supported on a single FS-250 fire alarm control panel. Model FS-RD2 mounts in a 2"-deep, 6-gang electrical box, and the plate on the display is suitable for flush mounting.

#### Programmable Remote Relays (FS-RU2)

Programmable relays are available on the Model FS-250 control panel. A remote processor board (Model FS-RU2) communicates with the main system board, via a RS-485 communication network. Model FS-RU2 processor board controls a relay board mounted adjacent to it.

## Specifications — (continued)

The relay board has eight (8) Form C relay contacts – rated at 1 amp at 28VDC maximum. Model FS-RU2 relay unit contains one (1) processor board and one (1) relay board, totaling eight (8) relays.

Each processor board can support up to three (3) relay boards simultaneously, totaling 24 programmable relays per processor board. Additional relay extender boards are available, Model FS-RE8. A total of eight (8) processor boards can be supported simultaneously by each FS-250 control panel.

### Programmable Serial Annunciator Drivers (FS-SAU2)

Programmable serial annunciator drivers are available on the Model FS-250 control panel. A remote processor board communicates with the main system board, via a RS-485 communication network. This processor board controls a serial-annunciator driver board mounted adjacent to the remote processor board. The driver board has 16 outputs for LEDs. All serial-annunciator outputs are supervised.

Model FS-SAU2 serial-annunciator unit contains one (1) processor board and one (1) serial-annunciator driver board to add 16 LED drivers. Each processor board can support up to four (4) additional driver boards simultaneously, totaling 64 programmable serial-annunciator drivers per processor board.

Additional serial annunciator extender boards are available as Model FS-SAE16. A total of eight (8) processor boards can be supported simultaneously by each Model FS-250 control panel.

### Programming / Configuration Options

Configuration of the FS-250 control panel can be accomplished in two ways: First, the operator interface includes a 16-button keypad. This keypad can be used to configure all system parameters – including custom messages and logic – directly at the panel with no other configuration tools. Secondly, the Model FS-CT2 configuration tool can be used on a laptop computer to upload, download, and edit the system configuration.

Model FS-CT2 configuration tool includes a connection cable for use between the FS-250 fire alarm control panel and a 9-pin serial connection on a laptop computer running Model FS-CT2 software. Use of Model FS-CT2 software requires a computer that runs on a Windows®-based PC operating system. Model FS-CT2 configuration tool can be used to generate configuration reports and download and print history.

Custom messages for system addresses consist of two (2) lines – 20 characters per line. The characters include upper and lower case letters as well as numbers, punctuation marks, and control characters. This 40-character custom message will be displayed for all events at that address.

## Technical Data

<b>Environmental:</b>	Operating Temperature: 32-120°F (0-49°C) Relative Humidity: up to 93% @ 90°F (32°C)
<b>Primary Power Supply:</b>	Primary Input Voltage: 120 VAC (60 Hz.) Maximum Primary Input Current: 2.4 Amps. @ 120 VAC
<b>Secondary Power Supply:</b>	24-volt, lead-acid battery with 7AH - 38AH capacity
<b>Auxiliary Power Outputs:</b>	Current - 0.5 Amp with resettable and non-resettable power outputs
<b>System Status Relays:</b>	Four (4) relays rated @ 1 Amp, 28 VDC resistive
<b>Notification Appliance Circuits:</b>	Rating per NAC circuit, 1.5A each, 6A max.
<b>Battery:</b>	Base cabinet accommodates a 12 AH battery set. Larger batteries require separate enclosures.

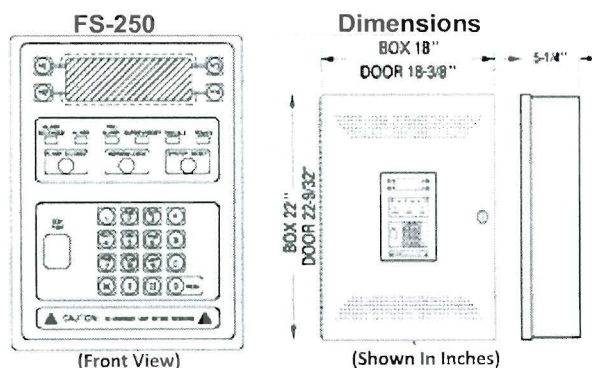

SIEMENS Industry, Inc.  
Building Technologies Division

## Details for Ordering

Model Number	Part Number	Description
FS-250-EKIT	599-050586	FS-250 Electronics Package Includes: FS-250-CON (1 Qty.) FS-NPE (2 Qty.)
FS-250-ENCL	500-648952	FS-250 Enclosure, Black
FS-250-ENCL-R	500-648953	FS-250 Enclosure, Red

### Optional Accessories

Model Number	Part Number	Description
FS-RD2-R	500-649400	Remote Annunciator, Red
FS-RD2	500-648980	Remote Annunciator, Black
FS-RU2	500-649308	Relay Processor Card
FS-RE8	500-699467	8-Relay Extender
FS-SAU2	500-649307	Serial Annunciator Processor Card
FS-SAE16	500-699469	16-Output Annunciator Extender
FS-DACT	500-699464	Serial Digital Alarm Comm. Transmitter (DACT)
FS-MT	500-699462	Municipal Tie Module
FS-SFT-R	500-648955	Semi-Flush Trim, Red
FS-SFT	500-648954	Semi-Flush Trim, Black
FS-NPE	500-649120	NAC Power Expander Transformer
HFPO-11	500-034800	Photo-Only Detector



# Wiring Diagram Main Termination Board

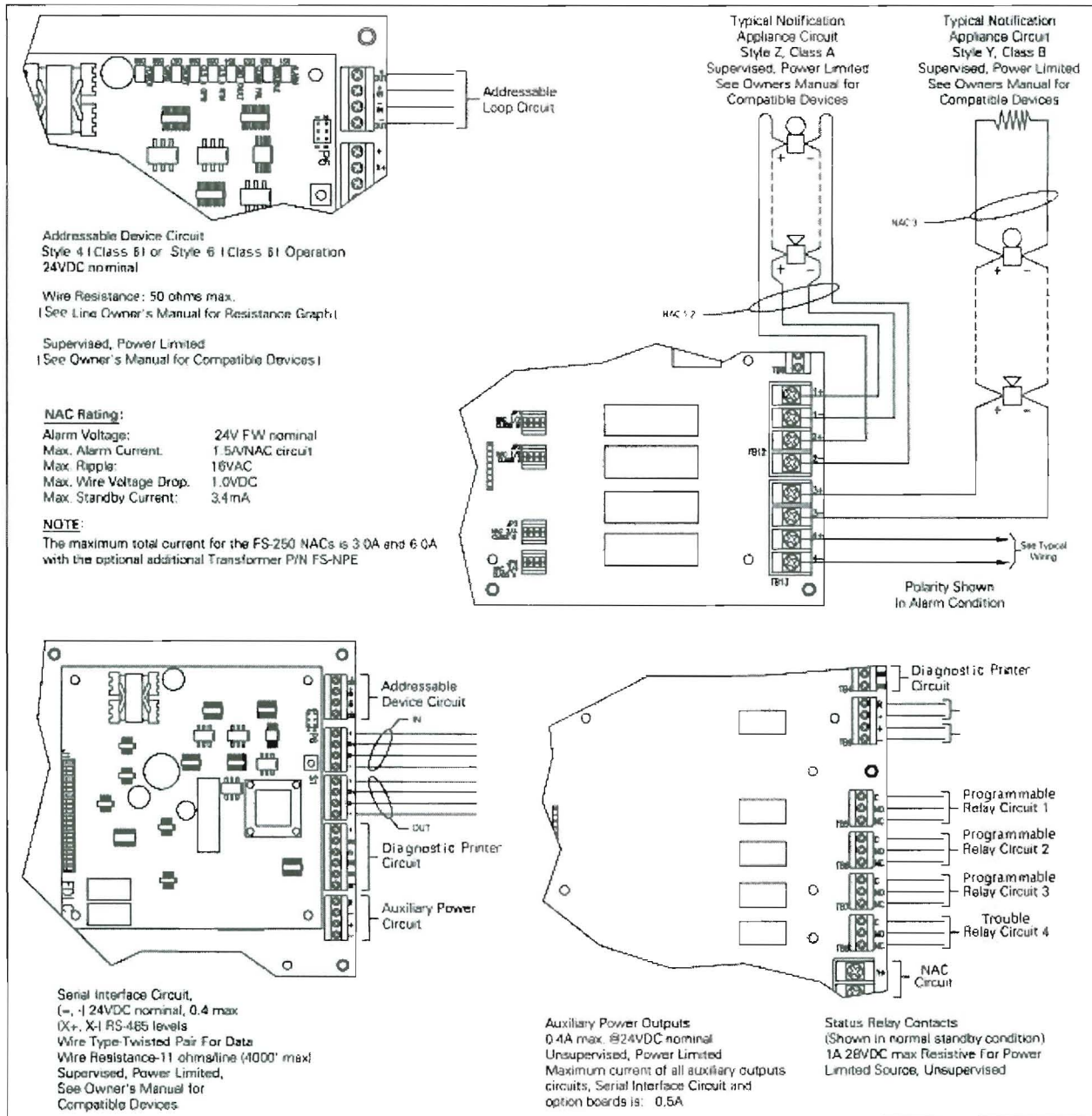

**Notice:** This marketing catalog sheet is not intended to be used for system design or installation purposes. For the most up-to-date information, refer to each product's installation instructions.

## FS-RD2

### Remote LCD Annunciator for the FireSeeker FS-250 System

#### ENGINEER AND ARCHITECT SPECIFICATIONS

- 4 x 20 Character Backlit Display
- System Status LEDs
- Optional local sounder
- Built-in lamp test button
- Integral System Control Capabilities (with keyswitch)
- Integral System Maintenance access (with keyswitch and password)
-  UL Listed



The Model FS-RD2 Remote Display is used for annunciating system events remotely from the fire alarm control panel on the FireSeeker FS-250 system. The FS-RD2 will mimic the system status LEDs and the 80-character event message found on the main system panel. The 4 x 20 LCD backlit display will illuminate upon receiving any event from the system, or upon pressing any button on the FS-RD2.

System Acknowledge, Silence and Reset Capabilities are available on the FS-RD2. The control functions must be enabled using the integral keyswitch. Up to sixteen supervised FS-RD2 annunciators can be used simultaneously on the FireSeeker FS-250 system.

Mounting is accomplished using a standard 6 gang 2" deep electrical box. The FS-RD2 requires a 2-wire data connection from the RS-485 port on the FS-250, as well as 24VDC power. Maximum wire loop resistance is 25 ohms.

#### Ordering Information

Model Number	Description	Part Number
FS-RD2	Remote LCD display for the FS-250	500-648980

**NOTICE:** The use of other than Fire Safety detectors and bases with Fire Safety equipment will be considered a misapplication of Fire Safety equipment and as such voids all warranties either expressed or implied in regard to loss, damage, liabilities and/or service problems.

Siemens Building Technologies  
**Fire Safety**

Fire Safety  
8 Fernwood Road  
Florham Park, NJ 07932  
Tel: (973) 593-2600  
FAX: (973) 593-6670  
Website: [www.sbt.siemens.com/fis](http://www.sbt.siemens.com/fis)

1/04  
5M  
SFS-IG  
Printed in U.S.A.

Fire Safety  
2 Kenview Boulevard  
Brampton, Ontario  
Canada L6T 5E4  
Tel: (905) 799-9937  
FAX: (905) 799-9858

**January 2004**  
Supersedes sheet dated 6/03

## FS-DACT

### Digital Alarm Communication Transmitter for the FireSeeker FS-250 System

#### ENGINEER AND ARCHITECT SPECIFICATIONS

-  UL Listed for Central Station/Remote Station Monitoring (NFPA 72 Chapter 4)
- Four separate monitoring accounts available
- Two phone lines available
- Can send serial information to monitoring station
- Reports in 8 standard communication formats
- Automatic 24 hour test available
- Mounts within the FS-250 enclosure directly on the main processor board
- All programming is done as part of the FS-250 configuration

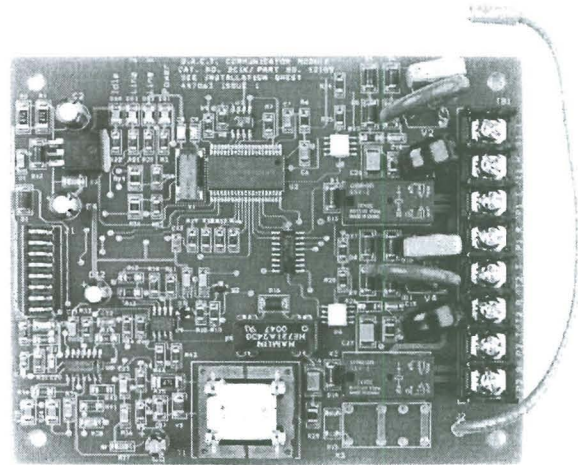

The Model FS-DACT Digital Alarm Communication Transmitter is used to provide communication between the FS-250 and a central or remote monitoring station. The FS-DACT supports two lines and four accounts, and can transmit serial information (including the address of the event) to the monitoring station. Any of the accounts can send alarm, supervisory, trouble, reset, or trouble restore information (or any combination) as required. Communication protocols available include SIA DCS 8, SIA DCS 20, Ademco Contact ID, 3/1 1400 Hz, 3/1 2300 Hz, 4/2 1400 Hz and 4/2 2300 Hz. The FS-DACT can perform the automatic 24 hour test required by NFPA.

The FS-DACT mounts within the FS-250 enclosure on an 8-pin connection point on the main board. No external enclosure is required, and no wires are required between the panel and the dialer. Programming of account and dialing information is done as part of the system configuration. No external programmer for the dialer is required, and dialer information can be downloaded as part of the system configuration.

#### Ordering Information

Model Number	Description	Part Number
FS-DACT	Digital dialer for the FS-250	500-699464

**NOTICE:** The use of other than Fire Safety detectors and bases with Fire Safety equipment will be considered a misapplication of Fire Safety equipment and as such voids all warranties either expressed or implied in regard to loss, damage, liabilities and/or service problems.

Siemens Building Technologies  
**Fire Safety**

Fire Safety  
8 Fernwood Road  
Florham Park, NJ 07932  
Tel: (973) 593-2600  
FAX: (973) 593-6670  
Website: [www.sbt.siemens.com/fis](http://www.sbt.siemens.com/fis)

1/04  
5M  
SFS:IG  
Printed in U S A.

Fire Safety  
2 Kenview Boulevard  
Brampton, Ontario  
Canada L6T 5E4  
Tel: (905) 799-9937  
FAX: (905) 799-9858

**January 2004**  
Supersedes sheet dated 6/03

# SIEMENS MSM SERIES

Fire Safety

## Metal Manual Fire Alarm Box

### ENGINEER AND ARCHITECT SPECIFICATIONS

- Rugged Die-Cast Metal Housing
- Reset Key Matches Control Panel
- Optional Break Glass Operation
- Single-Gang Semi-Flush Mount
- Optional Surface Mount Backbox
- Double-Action Institutional, Weather-Proof and Explosion-Proof Models Available
-  UL Listed, ULC Listed, CSFM, FM and NYMEA Approved

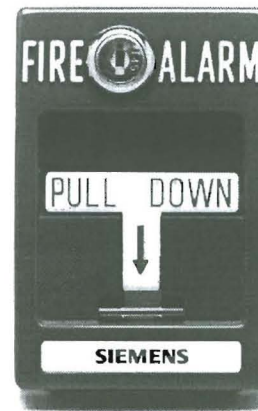

Standard Model  
Or Weatherproof



Institutional Model

### Description

The MSM Series manual stations feature a rugged die-cast metal housing that satisfies both architectural and code requirements for manual fire alarm box initiation devices. The MSM-Series box features keyed reset using the same key as the control panels.

The MSM Series models are low-profile with all surfaces either painted or plated to inhibit corrosion. These boxes have raised lettering and are shipped with two reset keys and a break glass rod (use of rod is optional.) Options include: double action, institutional, weatherproof, and explosion-proof.

These stations are equipped with a S.P.S.T. switch rated at 10amps @ 120 VAC and all connections are made to a terminal block. The explosion-proof model has a D.P.D.T. switch. **Both the weatherproof and explosion-proof models are shipped complete with backbox.** (Backbox is optional with other models, or you can mount to standard single-gang box.)

These models are intended for use with all Siemens Building Technologies, Fire Safety Division conventional zones, but can also be used with addressable zones when used in conjunction with a TRI-Series addressable module.

## Dimensions

### Station

Width 3.20 in.  
 Height 4.75 in.  
 Depth 1.20 in. (2.30 in. overall, including back of switch)

### Station w/Double Action

Width 3.33 in.  
 Height 4.57 in.  
 Depth 1.50 in. (2.60 in. overall, including back of switch)

### Weatherproof Model

Width 3.20 in.  
 Height 4.75 in.  
 Depth 2.75 in.

### Explosion-proof Model

Width 3.20 in.  
 Height 4.75 in. (6.00 in. overall, including mounting ears)  
 Depth 3.50 in.

## Ordering Information

Model Number	Description	Part Number
MSM-K	Manual Station, Metal w/Key	500-698215
MSM-KD	Manual Station, Metal w/Key, Double Action	500-698216
MSM-K-WP	Manual Station, Metal w/Key, Weatherproof	500-698217
MSM-KD-WP	Manual Station, Metal w/Key, Weatherproof, Double Action	500-698218
MSM-EXP	Manual Station, Metal w/Key, Explosion-proof	500-698219
MSM-INST	Manual Station, Metal w/Key, Institutional	500-698220
MSM-BOX	Surface Backbox for MSM-series Manual Stations	500-698221

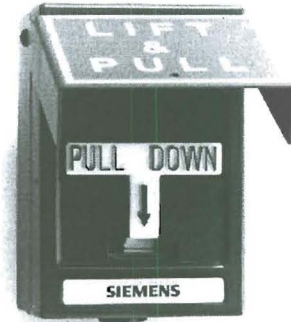

**Double Action Model**





**Explosion-proof Model**

# FireFinder XLS & FS-250 Control Panels

## Addressable *FirePrint*<sup>™</sup> Detector Model HFP-11

### ARCHITECT AND ENGINEER SPECIFICATIONS

- Most sophisticated 'detector intelligence' available
- Multi-criteria fire detection for the price of a photoelectric detector
- *FirePrint*<sup>™</sup> technology to differentiate between deceptive phenomena and an actual fire
- Easily programmed to match specific hazard profiles from the control panel
- Polarity insensitive utilizing *SureWire*<sup>™</sup> technology
- Pre-alarm reporting based on fire profile selected
- Remote sensitivity-measurement capability
- System logic activation based on any of three (3) inputs from the detector (smoke, heat or neural network)
- Detectors are self-testing:
  - complete diagnostics every four (4) seconds
- Two-wire operation
- Multi-color detector status LED
- Field-cleanable chamber with replaceable chamber parts available
- Compatible with Model DPU (device programmer / tester unit)
- Supports software-based automatic environmental compensation
- Optional fully programmable relay base, audible base and duct housing
- UL and ULC Listed;  
FM, CSFM & NYMEA Approved

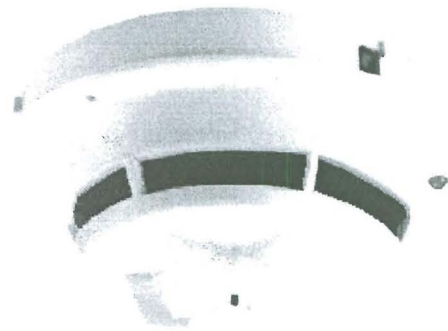

### Product Overview

Model HFP-11 utilizes advanced detection technology that allows the detector to distinguish non-threatening deceptive phenomena — such as cigarette smoke, from actual fire hazards, while optimizing detection for the area it is intended to detect. Model HFP-11 uses state-of-the-art microprocessor circuitry with error check, detector self-diagnostics and supervision programs.

Model HFP-11 is compatible with the Siemens — Fire Safety field device program / test unit (Model DPU), which is a compact, portable, menu-driven accessory for electronically programming and testing detectors, easily and reliably. Model DPU eliminates the need for cumbersome, unreliable mechanical programming methods — such as dials or switches, and reduces installation and service costs by electronically programming and testing the detector prior to installation. Model HFP-11 is compatible with FS-250 and Fire Finder XLS-series control panels.

Model HFP-11 is Underwriters' Laboratory and Underwriters' Laboratory of Canada listed.

### Specifications

Model HFP-11 is a plug-in, two-wire and multi-sensor detector (with both photoelectric and thermal inputs) that is compatible with Fire Finder XLS and FS-250 series of control-panel systems. Each detector consists of a dust-resistant, field-cleanable and photoelectric chamber; a solid state, non-mechanical thermal sensor, and microprocessor-based electronics with a low-profile plastic housing. Model HFP-11 utilizes state-of-the-art ASIC circuitry and surface-mount technology for maximum reliability.

Every Model HFP-11 fire detector is shipped with a protective dust cover. Model HFP-11 utilizes an infrared light emitting diode (IRLED), and light-sensing photodiode. Under normal conditions, light transmitted by the LED is directed away from the photodiode and scattered through the smoke chamber in a controlled pattern.

FS-250 and FireFinder XLS Control Panels **6301**



## Specifications – (continued)

The smoke chamber is designed to manage light dissipation and extraneous reflections from dust particles or other non-smoke, airborne contaminants in such a way as to maintain stable, consistent detector operation. When smoke enters the detector chamber, light emitted from the IRLLED is scattered by the smoke particles, and is received by the photodiode.

Model HFP-11 also utilizes a modern, accurate and shock-resistant thermistor to sense temperature changes. The 'on-board' *FirePrint*<sup>™</sup> technology allows the detector to first gather smoke and thermal data, and then analyze this information in the detector's 'neural network.' By comparing data received with the common characteristics of fires or fire fingerprints, Model HFP-11 can compare these 'fire prints' to those of deceptive phenomena that cause other detectors to false alarm.

### **FirePrint**

The advanced *FirePrint* technology allows Model HFP-11 to accurately determine a true fire hazard from unthreatening, deceptive phenomena. Further, the advanced *FirePrint* technology will not require a need to use alarm-delaying verification and confirmation techniques, which can increase the probability of losses due to fire. Model HFP-11 provides the highest level of detector intelligence available today with a detector / control panel link that allows the user to program the detector for the specific hazard profile, using a simple software menu selection.

Model HFP-11's *FirePrint* application monitors input from both the photo chamber and the thermal sensor, evaluating this information with sophisticated mathematical formulas or algorithms, comparing this input to characteristics of both threatening fires and deceptive phenomena that would mislead any ordinary detector.

Detectors are optimized by selecting one (1) of the following 11 applications:

- Office / Retail
- Lobby
- Computer room
- Dormitory
- Healthcare
- Parking garage
- Utility / Transformer room
- Hostile environment
- Precious storage
- Air Duct
- Warehouse / Light Manufacturing

The control panel programs Model HFP-11 detector for the protected area without hassle and without confirmation delays. Once optimized for the hazards in the protected area, Model HFP-11 provides the best detection. Should the operator or installer forget to program the detector, Model HFP-11 will revert to a default setting, allowing operation as an office-environment detector.

The *FirePrint* technology was developed over years of research and reviewing the results of over 20 years of fire test data in one of the world's most advanced fire-research centers.

The results of this research are the mathematical models that form the algorithms used in *FirePrint*. No other fire detector has this level of intelligence or this amount of research and development supporting its design. The microprocessor's software can identify and disregard false input caused by radio frequency (RFI) and electromagnetic (EMI) interference, while validating all *Trouble* conditions before annunciating or reporting to the control panel.

### **Model HFP-11**

The Model HFP-11 detector's microprocessor uses an integral EEPROM to store the detector's address and other critical operating parameters, which include the assigned program values for *Alarm* and *Trouble* thresholds.

Communication within the detector, as well as between Model HFP-11 and the control panel, or with Model DPU (field device programmer / test unit), are supervised and safe-guarded against disruption by reliable, microprocessor-based error checking routines.

Additionally, the micro-processor supervises all EEPROM memory locations, and provides a high degree of EEPROM-failure fault tolerance. Model HFP-11 determines its operating status to be *Normal* in *Alarm* or in *Trouble* modes, depending on the difference between the alarm threshold values stored in the detector's memory and the detector's latest analog measurement.

The detector then communicates changes in its status to the control panel. In addition, the FireFinder XLS control panel will sample the value of the analog signal for Model HFP-11 over a period of time, in order to determine if those values indicate excessive buildup in the photo chamber. If such is the case, the FireFinder XLS control panel will indicate the particular detector requires maintenance.

Model HFP-11 is listed as a self-testing device. The visible light emitting diode (LED) for Model HFP-11 flashes 'green' every four (4) seconds to indicate it is communicating with the control panel, as well as to indicate it has passed its internal self-test. Should the detector sense a fault or failure within its systems, the LED will flash 'amber,' and the detector will transmit that data to the control panel.

A quick visual inspection is enough to indicate the condition of the detector at any time. If more detailed information is required, a printed report can be provided from the Fire Finder XLS panel, indicating the status and settings assigned to each individual detector. When Model HFP-11 moves to the *Alarm* mode, it will flash 'red,' and will continue flashing until the system is reset at the control panel. Simultaneously, any user-defined, system-alarm functions programmed into the system are activated.

## Specifications – (continued)

Detector sensitivity, calibration and identification are dynamically supervised by the fire-alarm control panel (FACP). Detector sensitivity and pre-alarm levels are a function of the application chosen at the control panel, and are controlled by the panel. If an alternate, non-*FirePrint* mode is selected, then the sensitivity can be changed from the control panel.

All Model HFP-11 detectors use a surface mounting base, Model DB-11, which mounts on a 4-inch octagonal, square or single gang electrical box. The base utilizes screw-clamp contacts for electrical connections and self-wiping contacts for increased reliability. Model DB-11 can be used with the optional Model LK-11 detector locking kit, which contains 50 detector locks and an installation tool to prevent unauthorized removal of the detector head. Model DB-11 has integral decorative plugs to cover the outer mounting screw holes.

Model HFP-11 may be installed on the same initiating circuit with HMS series manual stations, HTRI series interfaces, HCP output control devices, or HZM series of addressable, conventional zone modules. All Model HFP-11 detectors can be cleaned in the field, when required, by simply removing the detector cover and unsnapping the photo chamber. There is also the option of cleaning the interior of the detector with a clean, soft cloth or brush, or by replacing the labyrinth and bug screen included in the detector maintenance kit, Model DMK-11.

All Model HFP-11 detectors are approved for operation within the UL-specified temperature range of 32 to 100°F (0 to 38°C).

### Model DPU

The Device Program / Test Unit accessory is used to program and verify the address of the detector. The technician selects the accessory's program mode, and enters the desired address. Model DPU automatically sets and verifies the address and tests the detector.

Model DPU operates on AC power or rechargeable batteries, providing flexibility and convenience in programming and testing equipment from practically any location.

When in the test mode, Model DPU will perform a series of diagnostic tests without altering the address or other stored data, allowing technicians to determine if the detector is operating properly.

## Application Data

Installation of the Model HFP-11 series of fire detectors requires a two-wire circuit. In many retrofit cases, existing wiring may be used. 'T-tapping' is permitted only for Style 4 (Class B) wiring. Model HFP-11 is polarity insensitive, which can greatly reduce installation and debugging time. Model HFP-11 fire detectors can be applied within the maximum 30 foot center spacing (900 sq. ft. areas,) as referenced in NFPA 72. This application guideline is based on ideal conditions, specifically, smooth ceiling surfaces, minimal air movement, and no physical obstructions between potential fire sources and the actual detector. Do not mount detectors in close proximity to ventilation or heating and air conditioning outlets. Exposed joints or beamed ceilings may also affect safe spacing limitations for detectors.

Should questions arise regarding detector placement, observe NFPA 72 guidelines. Good fire-protection system engineering and common sense dictate how and when fire detectors are installed and used. Contact your local Siemens Industry – Fire Safety distributor or sales office whenever you need assistance applying *FirePrint* in unusual applications. Be sure to follow NFPA guidelines and UL Listed / UL Listed installation instructions – included with every Siemens – Fire Safety detector – and local codes as for all fire protection equipment.

## Technical Data

<b>Operating Temperatures:</b>	+32°F (0°C) to 100°F (38°C), per UL 268 / 268A
<b>Humidity:</b>	0-93% Relative Humidity
<b>Non-condensing Maximum Spacing:</b>	30-foot Centers (900 Square Feet), per NFPA 72 Chapter 5 and ULCS-524

## Mounting Diagram

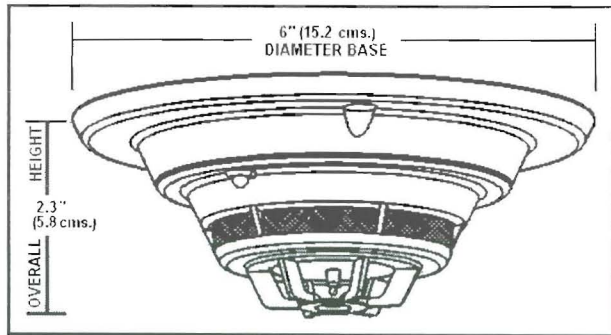

## Details for Ordering

Model Number	Part Number	Description
HFP-11	500-033290	Addressable <i>FirePrint</i> <sup>TM</sup> Fire Detector
DB-11	500-094151	Detector Mounting Base for Series 11
DB-11E	500-094151E	Detector Base {small}
AD2-P	500-649706	Air-Duct Housing
AD2-XHR	500-649708	Air-Duct Housing {with relay}
DB-HR	500-033220	Relay Base for H-Series Intelligent Detectors
ADBH-11	500-033210	Audible Base
RL-HC	500-033230	Remote Alarm Indicator: 4" octagon-box mount, red
RL-HW	500-033310	Remote Alarm Indicator: single-gang box mount, red
LK-11	500-695350	Base Locking Kit for Series 11 Detectors
DMK-11	500-695338	Series 11 Maintenance Kit {replacement labyrinth and bug screen}

### In Canada, order:

Model Number	Part Number	Description
DB-11C	500-095687	Detector Mounting Base for Series 11 Detectors (cULC)

**Notice:** This marketing catalog sheet is not intended to be used for system design or installation purposes. For the most up-to-date information, refer to each product's installation instructions.

**SIEMENS** Industry, Inc.  
Building Technologies Division

Fire Safety  
8 Fernwood Road  
Florham Park, NJ 07932  
Tel: (973) 593-2600  
FAX: (908) 547-6877  
URL: [www.SBT.Siemens.com/FIS](http://www.SBT.Siemens.com/FIS)

[SII-FS]  
Printed in U.S.A.

Fire Safety  
2 Kenview Boulevard  
Brampton, Ontario  
L6T 5E4 / Canada  
Tel: (905) 799-9937  
FAX: (905) 799-9858

**October 2010**  
Supersedes sheet dated 9/10  
(Rev. 3)

## '08 Series Notification Appliances

ZH & ZR – Strobes, Horns, & Horn / Strobes

Application: Indoor



ZH Series



ZR Series

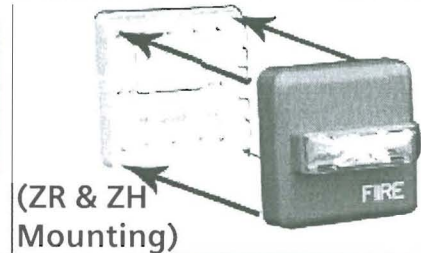

(ZR & ZH  
Mounting)

### Product Overview

- Strobes can be synchronized using the Siemens DSC sync modules, FS-250 panel, XLS panel, or PAD-3 power supply with built-in sync protocol
- Selectable Continuous Horn or Temporal (Code-3) Tones with 90 or 95 dBA selectable setting (ZH)
- Ceiling-mount models feature field-selectable Candela settings of 15/30/75/95cd and 115/177cd
- Wall-mount models feature field-selectable Candela settings of 15/30/75/110cd and 135/185cd
- Base plate is protected by a disposable cover, and the appliances can quickly snap onto the base after the walls are painted
- Strobes produce 1 flash per second
- "Special Applications" listed with Siemens panels
- EZ Mount Universal Mounting Plate (ZBB) – uses single plate for ceiling and wall mount installations
- EZ Mount design – with separate base plate – provides ability to pre-wire the base and test the circuit wiring before the walls are covered
- ⓈUL Listed & ⓈULC Listed;  
FM, CSFM & NYMEA Approved
- ADA / NFPA compliant

### Specifications

- **General**
  - Audible/Visual notification appliances shall be listed for indoor use only
  - Appliances shall be listed under ⓈUL Standard 1971 (Standard for Safety Signaling Devices for Hearing Impaired) and ⓈUL Standard 464 (Fire Protective Signaling)
  - Appliances shall use a universal back plate, which shall allow mounting to a single-gang, double-gang, 4-inch-square, 4"-octal, or a 3-1/2"-octal backbox
  - Two-wire appliance wiring shall be capable of directly connecting to the mounting back plate
  - Continuity check shall occur for entire NAC circuit prior to attaching any audible / visual-notification appliances
  - Dust cover shall fit and protect the mounting plate
  - Dust cover shall be easily removed when the appliance is installed over the back plate
  - Removal of an appliance shall result in a trouble condition by the Fire Alarm Control Panel (FACP)

## Specifications – (continued)

---

- **Strobes**
  - Strobe appliances shall produce a minimum flash rate of 60 flashes per minute (1 flash per second) over the Regulated Input Voltage Range, and shall incorporate a Xenon flashtube enclosed in a rugged Lexan® lens
  - Strobes shall be available with two or four field-selectable settings in one unit, and shall be rated – per ©UL 1971 – for up to:
    - 15/30/75/110cd for wall mounted
    - 135/185cd for wall mounted
    - 15/30/75/95cd for ceiling mounted
    - 115/177cd for ceiling mounted
  - Strobes shall operate over an extended temperature range of 32°F to 120°F (0°C to 49°C), and be listed for maximum humidity of 95% RH
  - Strobe inputs shall be polarized for compatibility with standard reverse-polarity supervision of circuit wiring by a Fire Alarm Control Panel (FACP)
- **Audibles and Audible / Strobe Combinations**
  - Horns and horn / strobes shall be listed for Indoor use under ©UL Standard 464
  - Horns shall be able to produce continuous synchronized output or a temporal code-3 synchronized output
  - Horns shall have at least 2 sound-level settings of 90 and 95 dBA
- **Synchronization Modules**
  - The strobe portion, when synchronization is required, shall be compatible with DSC sync modules, FS-250 panel, XLS panel, or PAD-3 power supply with built-in sync protocol
  - The strobes shall not drift out of synchronization at any time during operation
  - Audibles and strobes shall be able to synchronize on a 2-wire circuit with the capability to silence the audible, if required
  - Strobes shall revert to a non-synchronized flash-rate, if the sync module or Power Supply should fail to operate (i.e. – contacts remain closed)
  - All notification appliances shall be listed for Special Applications:
    - Strobes are designed to flash at 1-flash-per-second minimum over their “Regulated Input Voltage Range”
      - **Note:** NFPA-72 specifies a flash rate of 1-to-2 flashes per second, and ADA Guidelines specify a flash rate of 1-to-3 flashes per second
    - All candela ratings represent minimum-effective Strobe intensity, based on ©UL Standard 1971
    - Series ZH Strobe products are listed under ©UL Standards 1971 and 464 for indoor use with a temperature range of 32°F to 120°F (0°C to 49°C) and maximum humidity of 93% (± 2%)
    - Series ZH horns are listed under ©UL Standard 464 for audible signal appliances (Indoor use only)

## Mounting Diagram

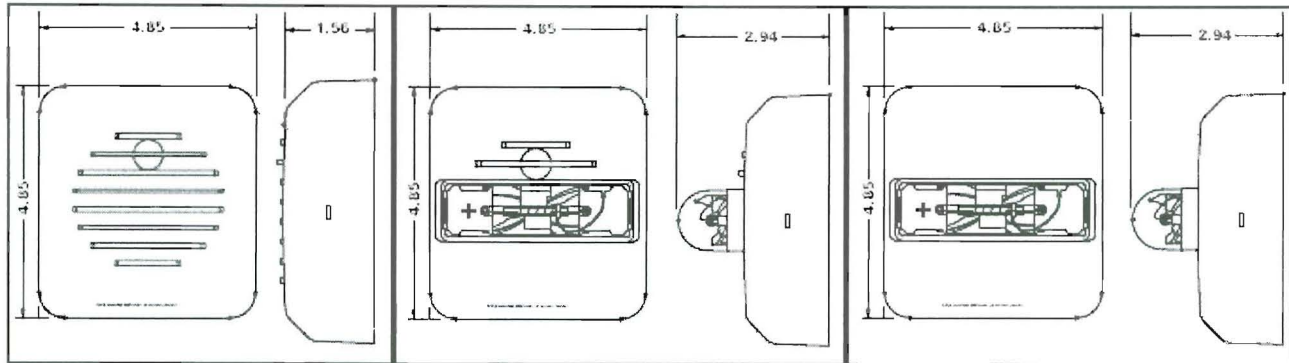

(Shown In Inches)

## Mounting Options

Figure 3: Installation

Figure 4: Removal (See step 8 below)

1. Install mounting plate as shown in figure 1 to a single-gang, double-gang, 4" square, 4" octagon, or a 3 1/2" octagon backbox with the provided pan head screws. To remove dust cover, place thumb and index finger on top edges of cover and pull off cover.
2. Connect field wiring per figures 2 and 3
3. Address wires back into backbox.
4. Place dust cover over mounting plate to protect the terminals while performing wiring continuity check.
5. Remove dust cover before snapping or installing the appliance onto the mounting plate per fig 3.
6. Important: Device only has one mounting orientation. Match the top of the base to the top of the device.
7. If it is desired to further secure the device to the base, then two optional screws are provided. To install these screws punch out the screw holes located at the top and bottom of the device.
8. To remove the appliance, push a small flat-bladed screwdriver into the side opening. The screwdriver must clear the snap release opening by 1/4" to disengage the snap. Do not pry off housing with the screw driver. Apply pressure with screw driver, inserted in either side opening, as shown in Fig 4 to release the housing.

## Technical Data

		ZH and ZH-MC Horn Reverberant dBA per UL464 [ZH-MC and ZH at 24V]		
		16.0V	24V	33.0V
Continuous Horn	High	83	87	90
	Low	77	81	83
Code 3 Horn or March Time*	High	79	82	86
	Low	72	76	79

\*Available in sync mode only

In (Amps)	ZH Horn Current Draw	
	Horn Setting	16-33 Volts
DC	High*	0.044
	Low*	0.018
FWR	High*	0.075
	Low*	0.045

\*Current Draw is the same for the Continuous Horn, Code 3 Horn, and March Time Settings.

## Technical Data – (continued)

Models*	UL Listed Models and Ratings				
	Operating Voltage (Special Application) [Per UL1971] (VDC/VRMS)	Voltage Range [Per ULCS526-02] (VDC/VRMS)	Horn	Mounting	Strobe Candela (cd)
ZR-MC	16.0-33.0	20.0-31.0	—	Wall	15/30/75/110
ZR-HMC	16.0-33.0	20.0-31.0	—	Wall	135/185
ZR-MC-C	16.0-33.0	20.0-31.0	—	Ceiling	15/30/75/95
ZR-HMC-C	16.0-33.0	20.0-31.0	—	Ceiling	115/177
ZH-MC	16.0-33.0	20.0-31.0	X	Wall	15/30/75/110
ZH-HMC	16.0-33.0	20.0-31.0	X	Wall	135/185
ZH-MC-C	16.0-33.0	20.0-31.0	X	Ceiling	15/30/75/95
ZH-HMC-C	16.0-33.0	20.0-31.0	X	Ceiling	115/177
ZH	16.0-33.0	20.0-31.0	X	Wall or Ceiling	— —

\*Available in red and white

		UL Current Ratings (ZR Strobe Only) Maximum RMS Current (AMPS)											
		MC				HMC		MC-C				HMC-C	
		15cd	30cd	75cd	110cd	135cd	185cd	15cd	30cd	75cd	95cd	115cd	177cd
DC	16-33VDC	0.064	0.098	0.175	0.233	0.318	0.445	0.069	0.111	0.200	0.264	0.318	0.445
FWR	16-33VRMS	0.108	0.164	0.268	0.368	0.482	0.684	0.117	0.180	0.297	0.398	0.482	0.684

		UL Current Ratings ZH Horn/Strobe Maximum RMS Current (AMPS)												
		Horn Setting	MC				HMC		MC-C				HMC-C	
			15cd	30cd	75cd	110cd	135cd	185cd	15cd	30cd	75cd	95cd	115cd	177cd
DC	16-33VDC	High*	0.078	0.113	0.195	0.259	0.371	0.506	0.087	0.131	0.222	0.292	0.371	0.506
		Low*	0.070	0.107	0.188	0.246	0.324	0.455	0.075	0.121	0.213	0.277	0.324	0.455
FWR	16-33VRMS	High*	0.141	0.200	0.302	0.406	0.521	0.722	0.149	0.216	0.331	0.436	0.521	0.722
		Low*	0.123	0.179	0.290	0.391	0.497	0.699	0.131	0.195	0.319	0.421	0.497	0.699

\* Current Draw is the same for the Continuous Horn; Code 3 Horn and March Time Settings

## Details for Ordering – (Including Mounting Options & Agency Approvals)

Model Number	Part Number	Description	Mounting Options*	Agency Approvals			
				UL	ULC	FM	CSFM
ZH-R	500-636159	Z Horn: Red	B,D,E,F	X	X	X	X
ZH-W	500-636160	Z Horn: White	B,D,E,F	X	X	X	X
ZH-MC-R	500-636161	Z Horn: Multi Candela (Wall), Red	B,D,E,F	X	X	X	X
ZH-MC-W	500-636162	Z Horn: Multi Candela (Wall), White	B,D,E,F	X	X	X	X
ZH-HMC-R	500-636163	Z Horn: Hi Multi Candela (Wall), Red	B,D,E,F	X	X	X	X
ZH-HMC-W	500-636164	Z Horn: Hi Multi Candela (Wall), White	B,D,E,F	X	X	X	X
ZH-MC-CR	500-636165	Z Horn: Multi Candela (Ceiling), Red	B,D,E,F	X	X	X	X
ZH-MC-CW	500-636166	Z Horn: Multi Candela (Ceiling), White	B,D,E,F	X	X	X	X
ZH-HMC-CR	500-636167	Z Horn: Hi Multi Candela (Ceiling), Red	B,D,E,F	X	X	X	X
ZH-HMC-CW	500-636168	Z Horn: Hi Multi Candela (Ceiling), White	B,D,E,F	X	X	X	X
ZR-MC-R	500-636169	Z Strobe: Multi Candela (Wall), Red	B,D,E,F	X	X	X	X
ZR-MC-W	500-636170	Z Strobe: Multi Candela (Wall), White	B,D,E,F	X	X	X	X
ZR-HMC-R	500-636171	Z Strobe: Hi Multi-Candela (Wall), Red	B,D,E,F	X	X	X	X
ZR-HMC-W	500-636172	Z Strobe: Hi Multi-Candela (Wall), White	B,D,E,F	X	X	X	X
ZR-MC-CR	500-636173	Z Strobe: Multi Candela (Ceiling), Red	B,D,E,F	X	X	X	X
ZR-MC-CW	500-636174	Z Strobe: Multi Candela (Ceiling), White	B,D,E,F	X	X	X	X
ZR-HMC-CR	500-636175	Z Strobe: Hi Multi Candela (Ceiling), Red	B,D,E,F	X	X	X	X
ZRS-HMC-CW	500-636176	Z Strobe: Hi Multi Candela (Ceiling), White	B,D,E,F	X	X	X	X
ZBB-R	500-636193	Accessory – (Includes base, dust cover, mounting screws and installation sheet)					
ZBB-W	500-636194	Accessory – (Includes base, dust cover, mounting screws and installation sheet)					

X = listed / approved

\* = Refer to catalog sheet #: 2585 for detailed mounting options

**Notice:** This marketing catalog sheet is not intended to be used for system design or installation purposes.

For the most up-to-date information, refer to each product's installation instructions.

# FireFinder XLS & FS-250 Control Panels

## Intelligent Thermal Detector Model HFPT-11

### ARCHITECT AND ENGINEER SPECIFICATIONS

- Microprocessor-based design
- Rate compensated
- Innovative technology provides high-speed, fault-tolerant system / detector communications
- Multi-color detector status LED
- Polarity insensitive utilizing *SureWire™* technology
- Detectors are self-testing:  
Complete diagnostics every four seconds
- Two-wire operation
- Compatible with DPU device programmer / tester unit
-  UL and  ULC Listed;  
FM, CSFM & NYMEA Approved





### Product Overview

Model HFPT-11 Intelligent Thermal Detector provides an advanced method of detection, address programming and supervision — combined with sophisticated control-panel communication. Model HFPT-11 uses a state-of-the-art thermistor that provides up to 135°F (57.2°C) rate-compensated temperature.

The Intelligent Thermal Detector is compatible with the Device Program / Test Unit (Model DPU). Model DPU is a compact, portable and menu-driven accessory that makes programming and testing detectors faster, easier and more reliable than other methods.

Model DPU eliminates the need for cumbersome, unreliable mechanical-programming methods, and reduces installation and service costs, via electronically programming addresses and functionally testing the HFPT-11's performance before the detector is installed.

The HFPT-11 thermal detector is  Underwriters' Laboratory and  Underwriters' Laboratory of Canada listed.

### Specifications

Model HFPT-11 is a plug-in, (2) two-wire thermal detector, compatible with the FireFinder XLS and FS-250 families of control panels. Each Model HFPT-11 detector has microcomputer-chip technology and highly stable, solid-state electronic circuitry.

Model HFPT-11 detectors utilize a modern, accurate and shock-resistant thermistor to sense temperature changes. This electronic-sensing method virtually eliminates thermal lag associated with mechanical temperature-sensing devices, and provides almost instantaneous temperature information to the control panel. Model HFPT-11, in its default mode, provides up to 135°F (57.2°C) rate-compensated temperature.

FireFinder XLS and FS-250 Control Panels **6302**



## Specifications – (continued)

Model HFPT-11 can be programmed from the control panel as a fixed temperature detector without rate-of-rise, at the user's option.

Model HFPT-11 detector's microprocessor uses an integral EEPROM to store the detector's address. Communications within the detector itself and between the HFPT-11 and the control panel, or with Model DPU, are supervised and safeguarded against disruption by reliable, microprocessor based error checking routines. Additionally, the microprocessor supervises all EEPROM memory locations, and provides a high degree of EEPROM failure-fault tolerance.

Model HFPT-11 is listed as a self-testing device. Model HFPT-11's visible light emitting diode (LED) flashes green every four (4) seconds to indicate it is communicating with the control panel, and to show it has passed its internal self-test. Should the detector sense a fault or failure within its systems, the LED will flash amber, and the detector will transmit that information to the control panel.

A quick visual inspection is sufficient to indicate the condition of the detector at any time. If more detailed information is required, a printed report can be provided from the FireFinder XLS panel indicating the status and settings assigned to each individual detector.

When Model HFPT-11 moves to the *alarm* mode, it will flash red and continue flashing until the control panel is reset. At that same time, any user-defined system alarm functions programmed into the system are activated.

A **Device Program / Test Unit** (Model DPU) is used to program and verify the detector's address. The user selects the program mode to enter the desired address. The DPU Programmer / Test Unit then automatically sets / verifies the address, as well as tests the detector.

Model DPU has rechargeable batteries, which allows a detector's address to be programmed by the user from the most convenient location. The user can also separately test the detector for functionality.

When the user selects the *test* mode, a series of tests are automatically conducted and the user is informed whether the detector has passed or failed.

Model HFPT-11 detector is compatible on the same FireFinder XLS or FS-250 initiating circuit with other H-series detectors, HMS manual stations, HTRI-series addressable interfaces, or HZM-series addressable, conventional zone modules.

Model HFPT-11 detectors use a surface mounting base, (Model DB-11), which mounts on a 4-inch octagonal, square or single gang electrical box. Relay base Model DB-HR mounts to a 4-inch-square-deep electrical box.

Audible base Model ADBH-11 also mounts to a 4-inch-square-deep electrical box. Model DB-11 as well as Models DB-HR and ADBH-11 use screw-clamp terminals for all electrical connections and self-wiping contacts for reliability. The bases also contain a provision for an optional, concealed locking mechanism to prevent unauthorized removal of the detector head, Model LK-11.

## Application Data

The FireFinder XLS and FS-250 control panels use loop circuits with each circuit capable of supporting up to 252 Model HFPT-11 intelligent detectors.

Locate Model HFPT-11 on the ceiling, at least 4 inches from the side walls. For an ideal, smooth ceiling condition, place the detectors at a maximum center spacing of 50 feet (2,500 square feet), 25 feet from side walls or room partitions. For FM-approved installations, Model HFPT-11 has a RTI rating of 'FAST.' Use a maximum center spacing of 25 feet (625 square feet), 12.5 feet from side walls or room partitions.

Actual job conditions and sound engineering judgment must determine detector spacing. Consider environmental factors including ambient temperature fluctuation, and the nature of the fire hazard. Room or area configuration and ceiling type (sloped or flat, smooth or beamed) also dictates placement.

Should questions arise regarding detector placement, follow the drawings provided and / or approved by Siemens Industry — Fire Safety Division or by its authorized distributors.

## Mounting Diagram

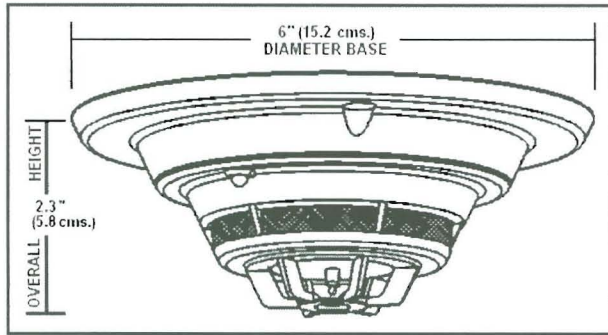

## Technical Data

Operating Temperatures:	+32°F (0°C) to 100°F (38°C), per @UL 269 / 268A
Humidity:	0-93% Relative Humidity Non-condensing
Maximum Spacing:	50-foot Centers (2500 Square Feet)
FM-Approved Spacing:	25-foot Centers (625 Square Feet)
Current Draw:	1mA in Alarm or Supervisory mode

## Details for Ordering

Model Number	Part Number	Description
HFPT-11	500-033380	Addressable Thermal Fire Detector
DB-11	500-094151	Detector Mounting Base
DB-HR	500-033220	Relay Base
ADBH-11	500-033210	Audible Base
RL-HC	500-033230	Remote (red) alarm indicator-octogan box mount
RL-HW	500-033310	Remote (red) alarm indicator-single gang box mount
LK-11	500-695350	Base Locking Kit for Series 11 detectors

### In Canada Order:

Model Number	Part Number	Description
ADBH-11C	500-033210C	Audible Base (ULC)
HFPT-11C	500-033380C	Addressable Thermal Fire Detector (ULC)
DB-11C	500-095687	Detector Mounting Base (ULC)
DB-HR-C	500-033220C	Relay Base (ULC)

**Notice:** This marketing catalog sheet is not intended to be used for system design or installation purposes.  
For the most up-to-date information, refer to each product's installation instructions.

**SIEMENS Industry, Inc.**  
Building Technologies Division

Fire Safety  
8 Fernwood Road  
Florham Park, NJ 07932  
Tel: (973) 593-2600  
FAX: (908) 547-6877  
URL: [www.SBT.Siemens.com/FIS](http://www.SBT.Siemens.com/FIS)

SII  
Printed in U.S.A.

Fire Safety  
2 Kenview Boulevard  
Brampton, Ontario  
L6T 5E4 / Canada  
Tel: (905) 799-9937  
FAX: (905) 799-9858

**June 2010**  
Supersedes sheet dated 7/09  
(Rev. 2)

## FireFinder XLS and FS-250 Panels

### HTRI Series Interface Modules

Models HTRI-D, HTRI-R and HTRI-S

#### ARCHITECT AND ENGINEER SPECIFICATIONS

- Interfacing and supervising normally open (NO) or normally closed (NC) contacts
- Integral SPDT relay on Model HTRI-R (up to 4 amps)
- Dual input on Model HTRI-D, using a single address
- Polarity insensitive with *SureWire™* technology
- Multi-color light-emitting diode (LED) indicates status [green / amber / red]
- Easy front access to programming port and wiring terminals
- Mounts 4-inch square, 2-¼"-deep box (or double-gang box)
- Dynamic supervision
- Comes with 5-x-5" faceplate
- Two-wire operation
- Model DPU programs and verifies address of the device and tests for proper functionality
- Electronic address programming is easy and dependable
- ©UL Listed & ©ULC Listed;  
FM, CSFM and NYMEA Approved



### Product Overview

The Siemens Industry, Inc. — Fire Safety HTRI Series Intelligent interface modules are designed to provide the means of interfacing direct shorting devices to the FireFinder XLS and FS-250 Fire Alarm Control Panel loop circuit.

The HTRI Series modules provide the most advanced method of address programming and supervision on the market — combined with sophisticated control panel communication. Each HTRI Series interface module incorporates a microcomputer chip. The HTRI Series microcomputer chip technology and its sophisticated bi-directional communication capabilities with the control panel, achieve the state of an 'intelligent device.'

### Specifications

The HTRI Series intelligent interface modules are available in three (3) models. Models HTRI-S and HTRI-R are designed to monitor a (NO) or (NC) dry contact.

The interface module reports the status of the (NO) or (NC) contact to the control panel. Model HTRI-S can only monitor and report the status of the contact, while Model HTRI-R incorporates an addressable Form C relay.

The Model HTRI-R relay and contact device input are controlled at the same address. For the control panel system, the relay and input contact can be controlled as a separate function. The relay is typically used where control or shunting of external equipment is required.

The Model HTRI-D is a dual-input module that is designed to supervise and monitor two (2) sets of dry contacts. Model HTRI-D only requires one (1) address, but responds independently to each input. Model HTRI-D is ideal for monitoring a water-flow switch and its respective valve tamper switch.

Model HTRI has a multi-color LED that flashes 'green' when operating in *normal*; 'amber' if unit is in *trouble* condition, and 'red' to indicate a change of state.

FireFinder XLS and FS-250 Panels **6304**

## Specifications (continued)

Model HTRI-D flashes twice — once for each address, and Model HTRI-R LED indicates a change of state in the relay. The device's microcomputer chip has the capacity of storing, in memory, identification information; as well as important operating-status information.

Siemens Industry, Inc., — Fire Safety innovative technology allows all HTRI Series intelligent interface modules to be programmed by using the Device Programming / Test Unit. Model DPU is a compact, portable and menu-driven accessory that makes programming and testing an interface device faster, easier and more dependable than previous methods.

Model DPU eliminates the need for mechanical addressing mechanisms, such as: program jumpers, DIP switches or rotary dials, since Model DPU electronically sets the HTRI Series interface address into the interface microcomputer-chip non-volatile memory. Vibration, corrosion and other conditions that deteriorate mechanical addressing mechanisms are no longer a cause for concern.

The HTRI Series is fitted with screw terminals for connection to an addressable circuit. The HTRI Series is fully compatible on the same FireFinder XLS and FS-250 circuits with all intelligent H-Series detectors, HMS Series addressable manual stations, or any other addressable intelligent modules, such as Model HZM or Model HCP.

All HTRI Series intelligent interface modules are ©UL listed. Environmental operating conditions for all HTRI Series modules are 32°F (°C) to 120°F (49°C) with a relative humidity of no greater than 93%, non-condensing.

## Electrical Ratings

Current Draw  
(Active or Standby) 1mA

### Model HTRI-R Relay Ratings

Resistive: 4 Amps, 125 VAC  
4 Amps, 30 VDC

Inductive: 3.5A, 120 VAC (0.6P.F.)  
3.0A, 30 VDC (0.6P.F.)  
2.0A, 120 VAC (0.4P.F.)  
2.0A, 120 VAC (0.35P.F.)  
2.0A, 30 VDC (0.35P.F.)

**Notice:** This marketing catalog sheet is not intended to be used for system design or installation purposes. For the most up-to-date information, refer to each product's installation instructions.

## Mounting Diagram

Models HTRI-S, HTRI-D and HTRI-R mount directly into a 4-inch square, 2 1/4-inch deep box or a double-gang box (user supplied). A 5-inch square, off-white faceplate is included with each HTRI Series module.

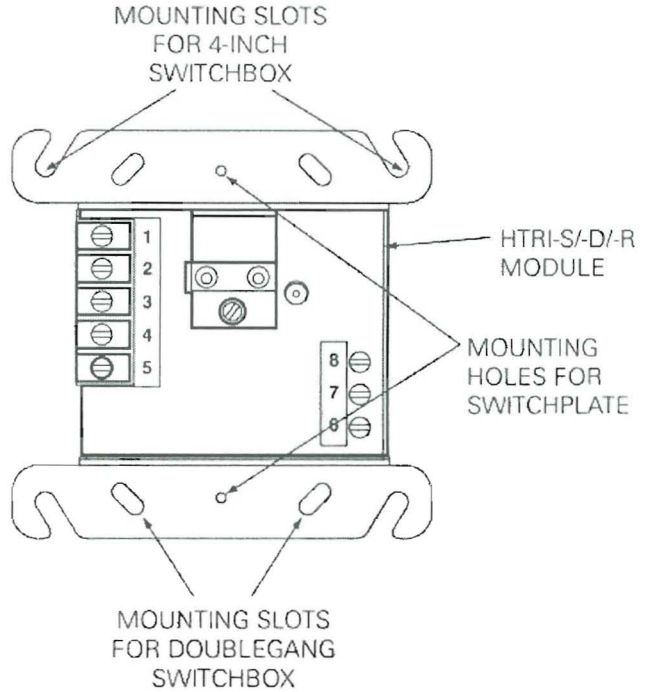

## Details for Ordering

Model Number	Part Number	Description	Shipping Wgt.	
			Lb.	Kg.
HTRI-S	500-033370	Single Input	7 oz.	2
HTRI-R	500-033300	Single Input w/Relay	7 oz.	2
HTRI-D	500-033360	Dual Input	7 oz.	2

**SIEMENS Industry, Inc.**  
Building Technologies Division

Fire Safety  
8 Fernwood Road  
Florham Park, NJ 07932  
Tel: (973) 593-2600  
FAX: (908) 547-6877  
URL: [www.SBT.Siemens.com/FIS](http://www.SBT.Siemens.com/FIS)

(SII)  
Printed in U.S.A.

Fire Safety  
2 Kenview Boulevard  
Brampton, Ontario  
L6T 5E4 / Canada  
Tel: (905) 799-9937  
FAX: (905) 799-9858

**June 2010**  
Supersedes sheet dated 12/04  
(Rev. 1)

## HTRI-M Intelligent Device Interface Module

For Use With the FireFinder-XLS and FS-250 Control Panel

### ENGINEER AND ARCHITECT SPECIFICATIONS

#### Intelligent Interface Modules For FireFinder™ XLS and FS-250 Control Panels

- Interfaces and Supervises Normally Open (Fire Detection) or Normally Closed Contacts (Security Detection)
- Compact Size Allows Mounting in Single Gang Box Behind Equipment
- Polarity Insensitive with SureWire™ Technology
- Operates with FireFinder XLS DLC Circuit
- Innovative Technology Supports Comprehensive System and Interface Communication
- Dynamic Supervision
- Two Wire Operation
- DPU Device Program/Test Unit Electronically Programs and Verifies Device's Address and Tests Device's Functionality
-  ULC Listed  
CSFM, FM and NYMEA Pending



### Introduction

The HTRI-M Intelligent interface module is designed to provide the means of interfacing direct shorting devices to the FireFinder XLS or FS-250 system's DLC loop circuit.

The HTRI-M Intelligent interface module provides the market's most advanced method of address programming and supervision, combined with sophisticated control panel communication. Each HTRI-M interface module incorporates microcomputer chip technology and its sophisticated bi-directional communication capabilities with the control panel.

### Description

The HTRI-M is designed to monitor a normally open or closed dry contact and reports the contact's status to the control panel.

The device's microcomputer chip has the capacity of storing, in memory, identification information as well as important operating status information.

Siemens Building Technologies, Inc. innovative technology allows all HTRI-M intelligent interface modules to be programmed by using the DPU Device Program/Test Unit. The DPU is a compact, portable, menu driven accessory that makes programming and testing an interface device faster, easier and more dependable than previous methods. The DPU eliminates the need for mechanical addressing mechanisms, such as program jumpers, DIP switches or rotary dials, because it electronically sets the HTRI-M interface's address into the interface's microcomputer chip non-volatile memory. Vibration, corrosion and other conditions that deteriorate mechanical addressing mechanisms are no longer a cause for concern. This HTRI-M is connected to the program/tester with the programming cable provided with the tester. This cable (P/N 110-694927) utilizes two (2) alligator clip connectors, to attach to the HTRI-M

The HTRI-M Series has five leads, one for grounding, which are wired to the system with user supplied wire nuts.

The HTRI-M is fully compatible on the same DLC circuit with all intelligent H Series detectors, HMS Series addressable manual stations or any other H Series addressable intelligent modules, such as the HZM or HCP

All HTRI-M intelligent interface modules have been UL and ULC submitted.

Environmental operating conditions for all HTRI-M modules are 32°F (°C) to 120°F (49°C) with a relative humidity of not greater than 93% non-condensating.

## Ordering Information

Model Number	Description	Shipping oz.	Weight kg.	Part Number
HTRI-M	Single Input	3.5	.1	500-034000
HTRI-MC	ULC Model for Canada	3.5	.1	500-034000C

## Electrical Ratings

Current Draw (Active or Standby): 1.5mA

**NOTICE:** The use of other than Fire Safety detectors and bases with Fire Safety equipment will be considered a misapplication of Fire Safety equipment and as such void all warranties either expressed or implied with regard to loss, damage, liabilities and/or service problems.

Siemens Building Technologies  
**Fire Safety**

Fire Safety  
8 Fernwood Road  
Florham Park, NJ 07932  
Tel: (973) 593-2600  
FAX: (973) 593-6670  
Website: [www.sbt.siemens.com/fis](http://www.sbt.siemens.com/fis)

6/06  
5M  
SFS-IG  
Printed in U.S.A.

Fire Safety  
2 Kenview Boulevard  
Brampton, Ontario  
Canada L6T 5E4  
Tel: (905) 799-9937  
FAX: (905) 799-9858

**June 2006**  
Supersedes sheet dated 5/06

UL Listed

# 7744/7788

**AES** IntelliNet  
CORPORATION | For Alarm Monitoring

**NEW!**

## RF Subscriber Unit

UL Fire, AA Burglary and NFPA-72 Compliant

UL Listed

UL Listed Central  
Station

Remote Station

864 Ed. 9, 827, 1610,  
365, 681

CSFM

NFPA  
RF Section 8.6.3.5

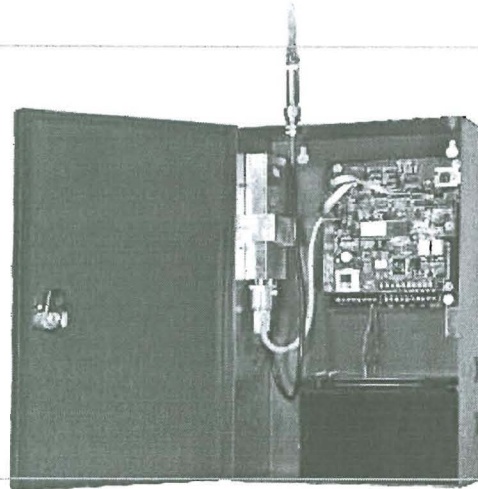

- Options for Full Data for Fire and Burglary
- Available in 7744 & 7788 Zone Configurations
- Built-in Power Supply and Battery Charger
- Local Annunciation Options on Board

### Advanced Wireless Alarm Monitoring

The 7744/7788 smart subscriber unit links an alarm panel to an alarm monitoring central station. This 2-way transceiver and repeater in one is housed in a full size locking steel cabinet for superior performance. The 7744/7788 supports a wide range of inputs such as NO/NC/EOL and direct voltage. It automatically senses wire and antenna cuts, and monitors battery and AC power status. Advanced status reporting, self-diagnostics and a built-in power supply make the 7744/7788 the first choice for all wireless alarm communication needs.

### Full Data for Fire and Burglary

Use with the optional FireTap for full fire data or the IntelliTap for full fire and burglary data.

#### Available Configurations

**7744** – 4 reversing polarity inputs plus 4 programmable EOL inputs

**7788** – Programmable EOL inputs with 8 zones

#### Available Options

FireTap 7770  
IntelliTap 7067  
NEMA 4 Enclosure  
High Gain Antenna  
Additional Back Up Battery  
Available in Burglary Beige or Fire Red

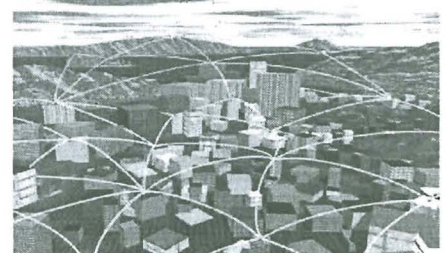

Wireless mesh networking is an innovative technology adopted by many industries with applications that need to communicate data over a large geographic area with a high level of reliability at a low total cost of ownership.

The advanced design and 2-way communications capability provides easy installation, expansion, and management when compared to alternative communication methods, both wired and wireless.



# RF Subscriber Unit

## Technical Specifications

### Radio

Standard CSAA frequency ranges:  
450-470 MHz and 130-174 MHz, VHF  
and UHF. Others available

### Standard Output Power

2 watts (requires FCC license)

### Power Input

16.5 VAC, 40VA UL listed  
Class II transformer required

### Voltage

12 VDC nominal

### Current

175mA standby; 800mA transmit

### Alarm Signal Inputs

- 4 individually programmable Zones:  
NO/NC/EOL, trouble restore
- RS-232
- Reversing voltage (7744 only) 12 or  
24 VDC

### Operating Temperature Range

0° to 50°C, 32° to 122°F

### Storage Temperature Range

-10° to 60°C, 14° to 140°F

### Relative Humidity Range

0-85% RHC non-condensing

### Back up Battery

12V, 7 AH

### Low Battery Reporting

22.5-minute test cycle

### AC Status

Reports to central station after  
approximately 60 minutes without AC  
power, reports power restored after  
approximately 60 minutes of restored  
power. programmable from 60 to 180  
minutes

### Antenna Cut (local reporting)

Form 'C' Contact 1 AMP

### Size

13.25"H x 8.5"W x 4.3"D  
34cm x 21.5cm x 11cm

### Weight

6.4 lbs, 2.9 Kilograms  
(excluding battery)

### Colors

Available in standard  
Burglary Beige or Fire Red  
Please specify when ordering

### Available Options

- 7788 RF subscriber unit  
with 8 EOL inputs
  - 7744 RF subscriber unit with 4 EOL  
inputs and 4 reverse polarity inputs
  - 7770 - FireTap
  - 7067 - IntelliTap
  - NEMA 4 Enclosure
- Please specify when ordering

## Available configurations

- 7788, 8 EOL inputs
- 7744, 4 EOL inputs w/4  
reverse polarity inputs

AES-IntelliNet is the industry leader in delivering high quality wireless mesh networks to the fire and security industry in commercial, corporate, government, and educational applications with its broad line of products and advanced network management tools. Users of AES-IntelliNet networks have gained significant revenue, communications, and cost advantages while meeting the high standards of reliability required for the fire and security industry. AES-IntelliNet alarm monitoring systems are deployed at hundreds of thousands of locations in over 130 countries.



For more information

Call 800-AES-NETS (800-237-6387)

AES Corporation | 285 Newbury Street | Peabody, MA 01960 USA

Tel. +1 978-535-7310 | Fax +1 978-535-7313 | Email [info@aes-intellinet.com](mailto:info@aes-intellinet.com)

Web [www.aes-intellinet.com](http://www.aes-intellinet.com)

Copyright 2008 AES Corporation  
AES-IntelliNet is a registered trademark of AES Corporation

7744/7788/02/08



# CITY OF PORTLAND, MAINE

Department of Building Inspections

## Original Receipt

7.1. 20 11

Received from \_\_\_\_\_

Location of Work \_\_\_\_\_

Cost of Construction \$ \_\_\_\_\_ Building Fee: 190

Permit Fee \$ \_\_\_\_\_ Site Fee: 5

Certificate of Occupancy Fee: \_\_\_\_\_

Total: 275

Building (I1) \_\_\_\_\_ Plumbing (I5) \_\_\_\_\_ Electrical (I2) \_\_\_\_\_ Site Plan (U2) \_\_\_\_\_

Other \_\_\_\_\_

CBL: 292 27 F-11

Check #: 12336 Total Collected \$ 275

**No work is to be started until permit issued.  
Please keep original receipt for your records.**

Taken by: P.J.

WHITE - Applicant's Copy  
YELLOW - Office Copy  
PINK - Permit Copy

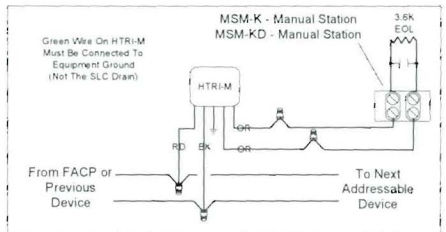
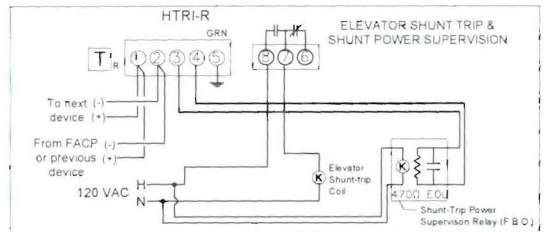
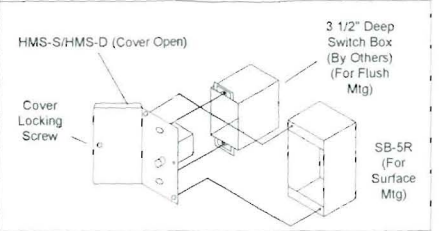
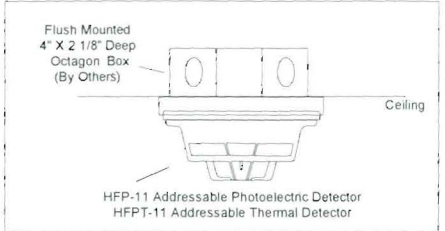
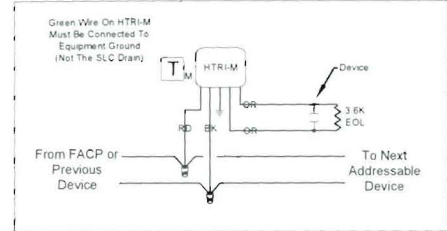
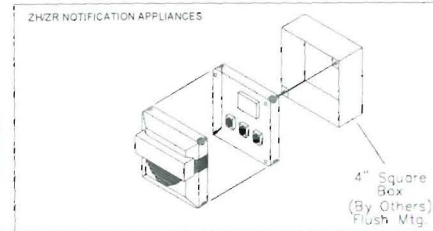
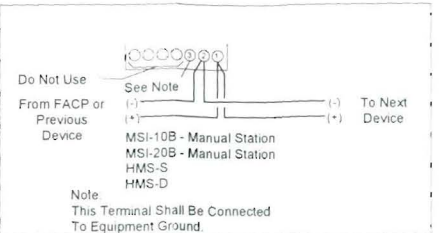
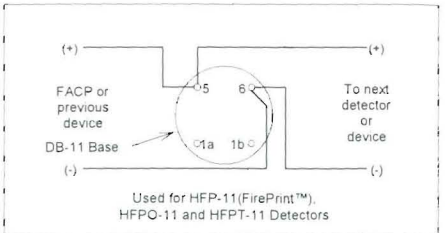
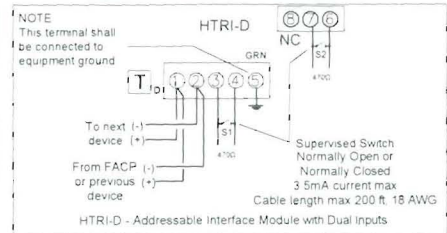
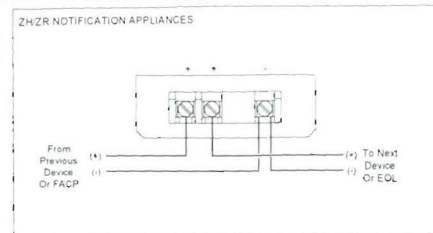

### DEVICE LEGEND

ITEM	QTY	SYM	ITEM	P/N	NOTE
1	1	FACP	FIRE ALARM CONTROL PANEL	FS-250	
2	1	FANN	FIRE ALARM ANNUNCIATOR	FS-RD2	
3	1	DACT	DIGITAL ALARM COMMUNICATION/TRANSMITTER	FS-DACT	
4	1	RADIO	RADIO MASTER BOX	AES7788	
5	18	F	MANUAL PULL STATION W/KEY SWITCH	MSM-KD/HTRI-M	
6	6	P	SMOKE DETECTOR	HFP-11	
7	34	⊠	HORN/STROBE	ZH-MC-R	MT. 80" A.F.F.
8	26	⊠	STROBE	ZR-MC-R	MT. 80" A.F.F.
9	1	H	HEAT DETECTOR	HFPT-11	
10	1	T <sub>M</sub>	SINGLE INPUT INTERFACE MINI MODULE	HTRI-M	
11	3	T <sub>D</sub>	DUAL INPUT INTERFACE MODULE	HTRI-D	
12	1	T <sub>R</sub>	SINGLE INPUT INTERFACE MODULE WITH RELAY	HTRI-R	
13	2	T <sub>S</sub>	SINGLE INPUT MODULE	HTRI-S	
14	4	T <sub>S</sub>	TAMPER SWITCH	TBD	TBD
15	2	F <sub>S</sub>	FLOW SWITCH	TBD	TBD

**DEVICE MOUNTING & WIRING DETAIL**

SCALE: N.T.S.

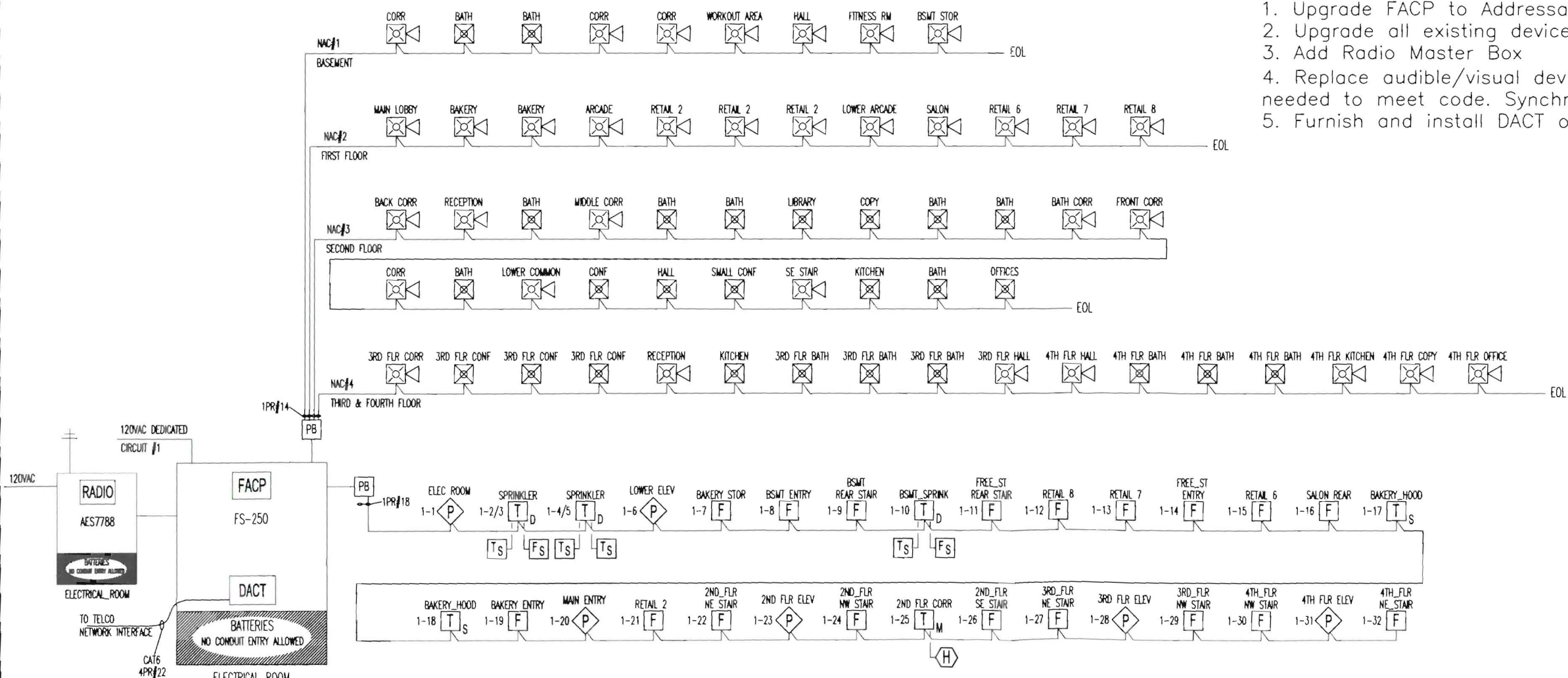

**FIRE ALARM RISER DETAIL**

SCALE: N.T.S.

**Scope of Work:**

1. Upgrade FACP to Addressable
2. Upgrade all existing devices to Addressable
3. Add Radio Master Box
4. Replace audible/visual devices and add new as needed to meet code. Synchronize devices, also.
5. Furnish and install DACT on FACP.

NO.	REVISIONS

REQUIRED APPROVALS  
CONTRACTOR/ENGINEER  
LOCAL FIRE DEPARTMENT

DRAWN BY: DRS  
CHECKED BY: BWB

PROJECT:  
**ONE MONUMENT WAY**  
PORTLAND, MAINE

FIRE ALARM CONTRACTOR:  
**EASTERN FIRE SERVICES, INC.**  
AUBURN/LEWISTON INDUSTRIAL AIRPARK, AUBURN, MAINE 04210  
170 KITTYHAWK AVENUE, P.O. BOX 1390  
Phone: (207)754-1507 Fax: (207)782-0566

CONTRACT WITH:  
**PARAGON MANAGEMENT**

DWG. NO. <b>FA-1</b>	JOB NUMBER EFSFA45B77
	SCALE 1/8" = 1'-0"
RISER DETAIL	DATE 6/27/11