

2.5 PLOT PLAN  
SCALE: N.T.S.

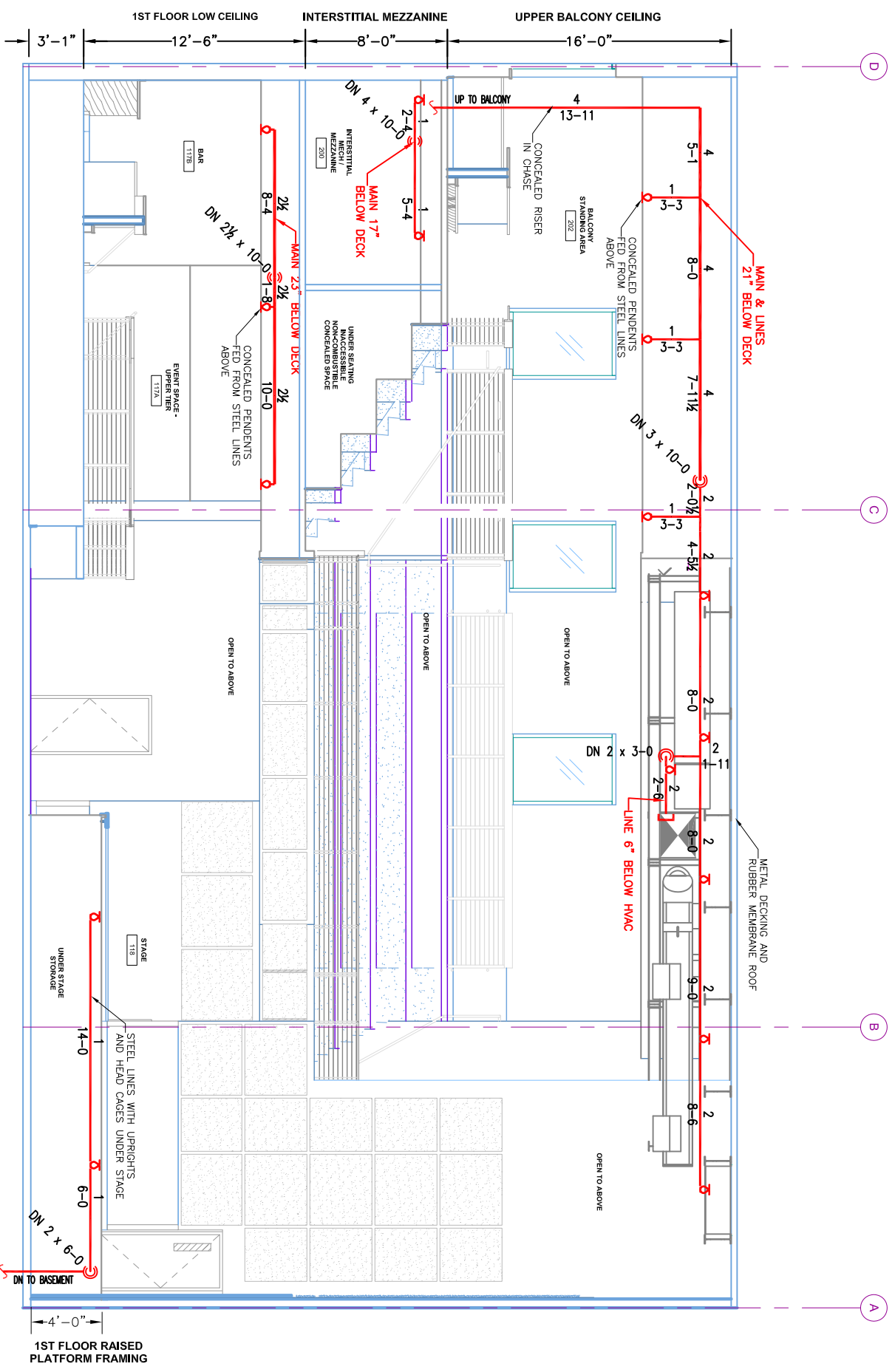

2.3 SECTION 'A' DETAIL  
SCALE 1/8" = 1'-0"

\*DESIGN AREA NUMBER 14  
 TOTAL SPRINKLER DESIGN CENTERLINE  
 TYPE OF SYSTEM: WET, 13 WET  
 NUMBER OF SPRINKLERS: 18 OF 200 GPM  
 MODEL CLASS: QLOBT\* (MODEL GROUP 2)  
 SYSTEM DRAWING INCLUDING HOSE 9  
 DATE OF REVISION: 11-29-2016

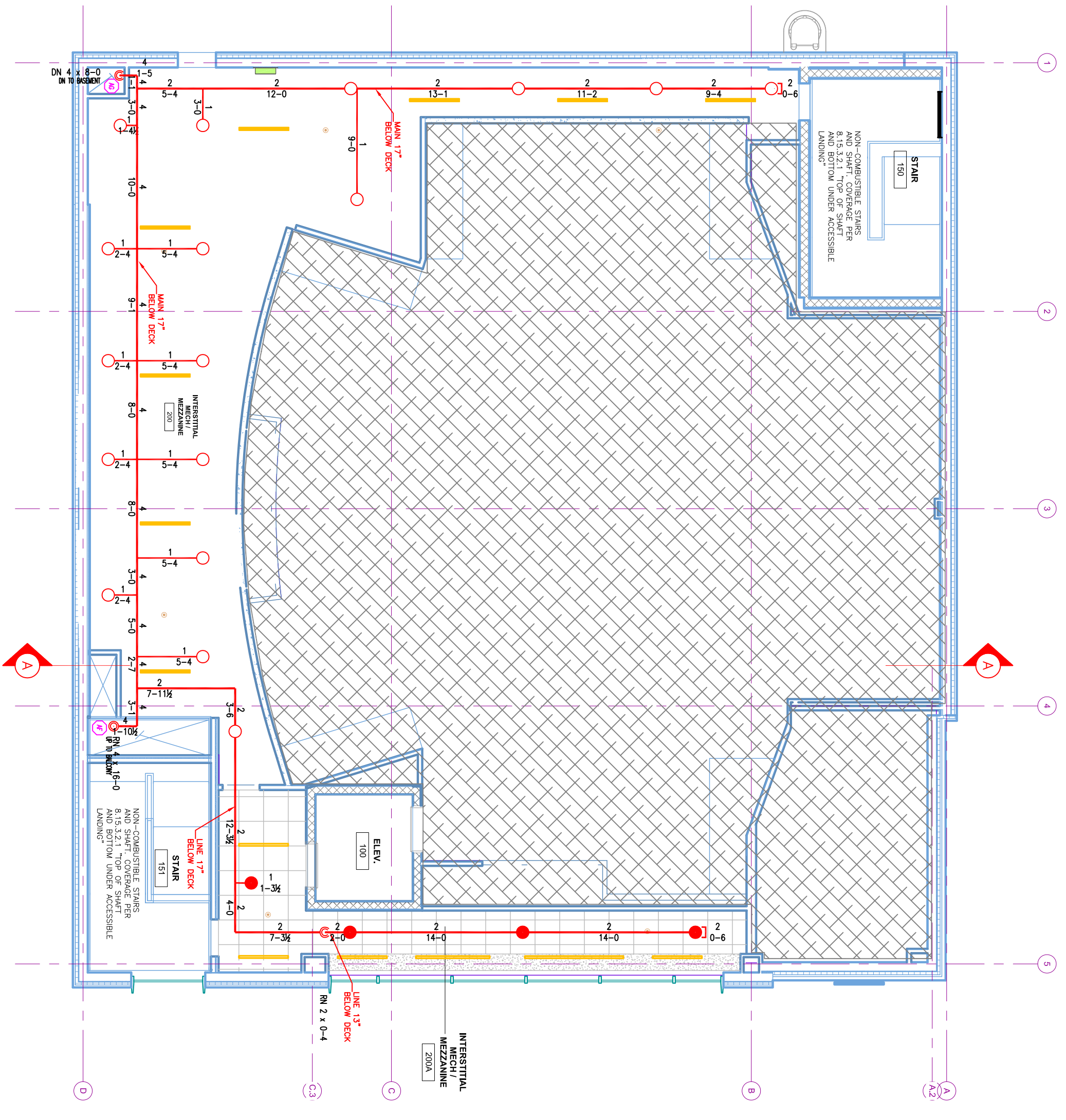

2.1 INTERSTITIAL MEZZ LEVEL  
TOTAL PROTECTED AREA 1,440 SQ.FT.  
SCALE 1/8" = 1'-0"

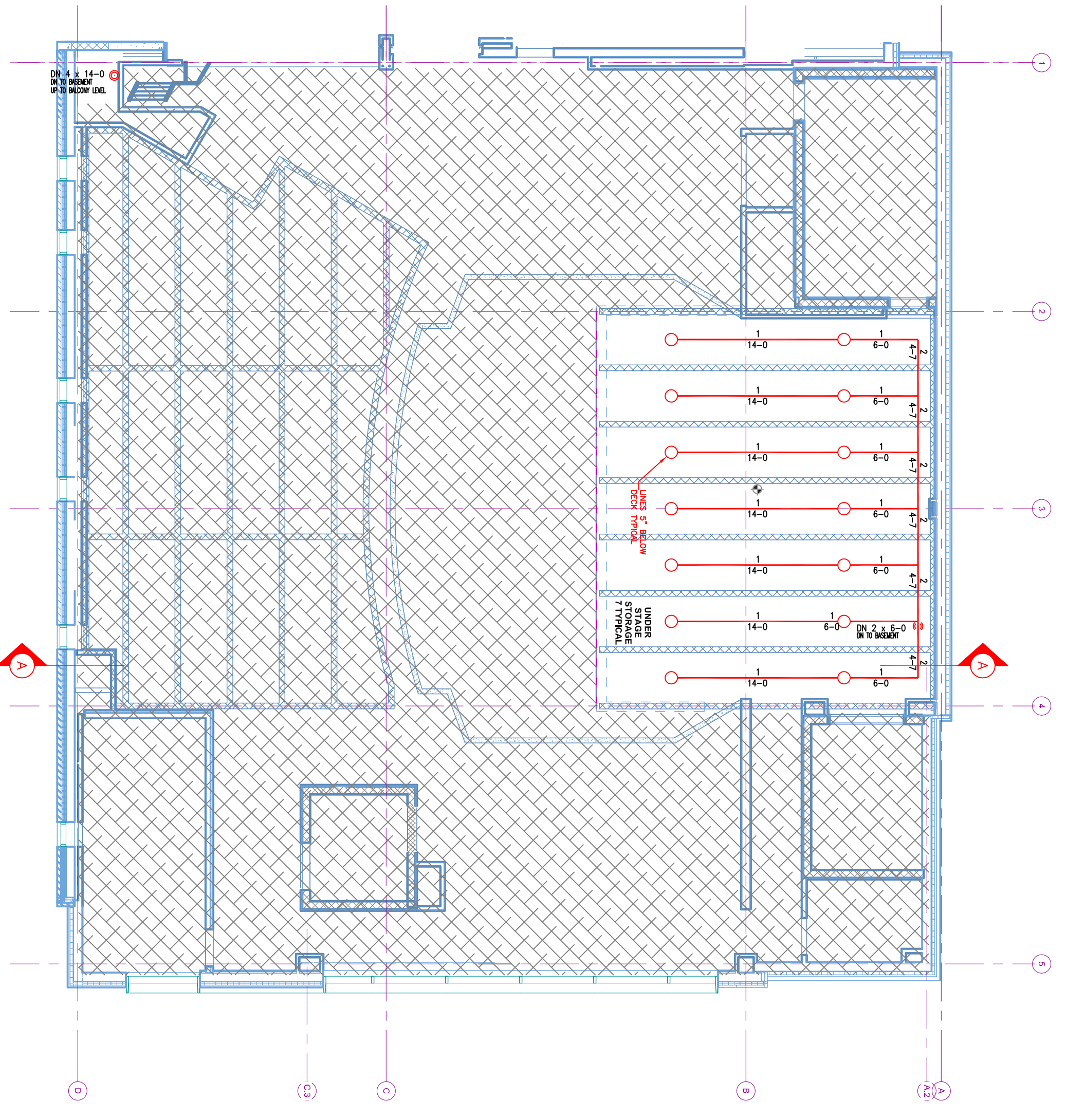

2 UNDER STAGE LEVEL  
TOTAL PROTECTED AREA 870 SQ.FT.  
SCALE 1/8" = 1'-0"

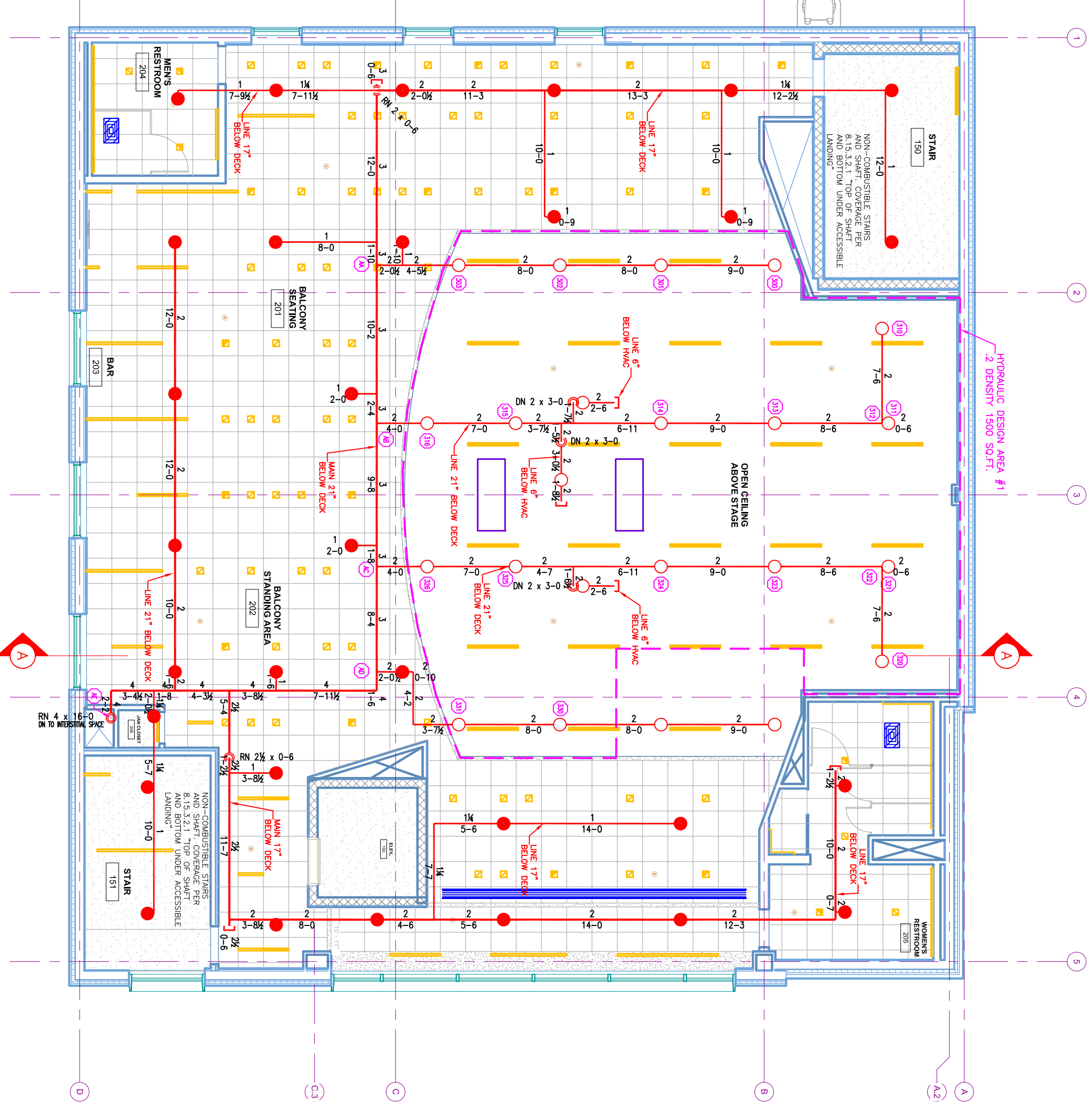

2.2 UPPER BALCONY LEVEL  
TOTAL PROTECTED AREA 5,100 SQ.FT.  
SCALE 1/8" = 1'-0"

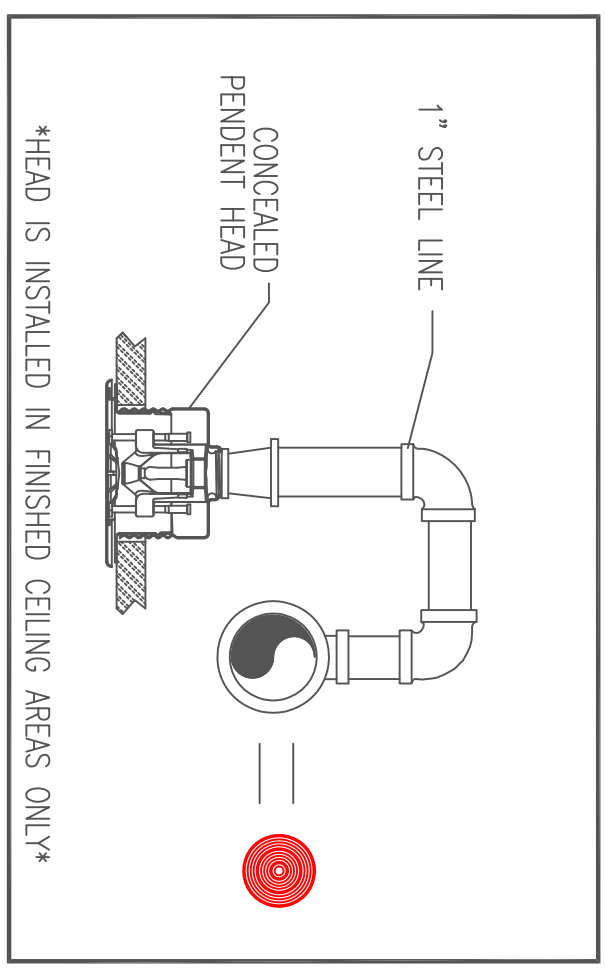

\*HEAD IS INSTALLED IN FINISHED CEILING AREAS ONLY\*

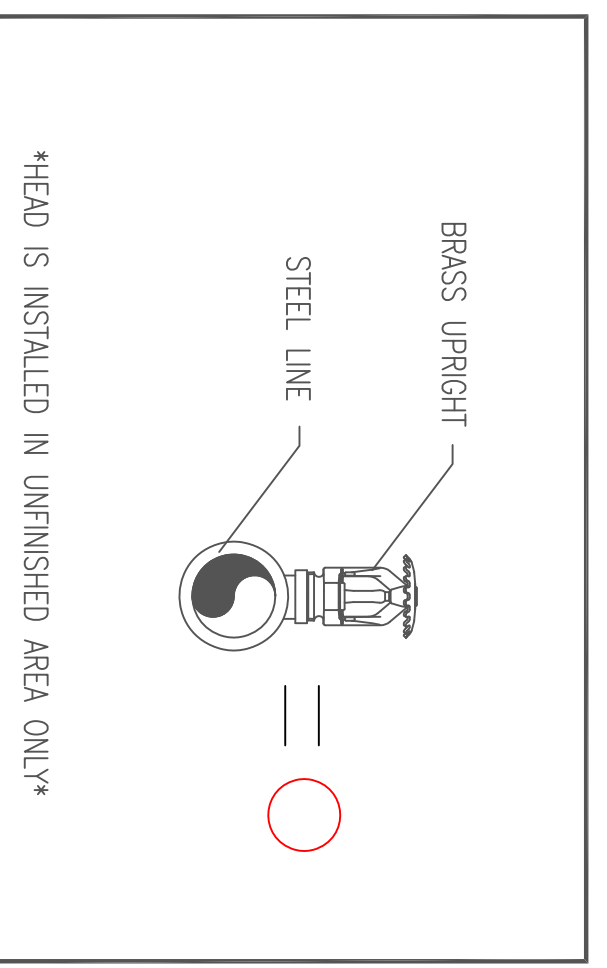

\*HEAD IS INSTALLED IN UNFINISHED AREA ONLY\*

2.4 HEAD DETAILS  
SCALE: N.T.S.

