

K1 SECTION
1 1/2" = 1'-0"

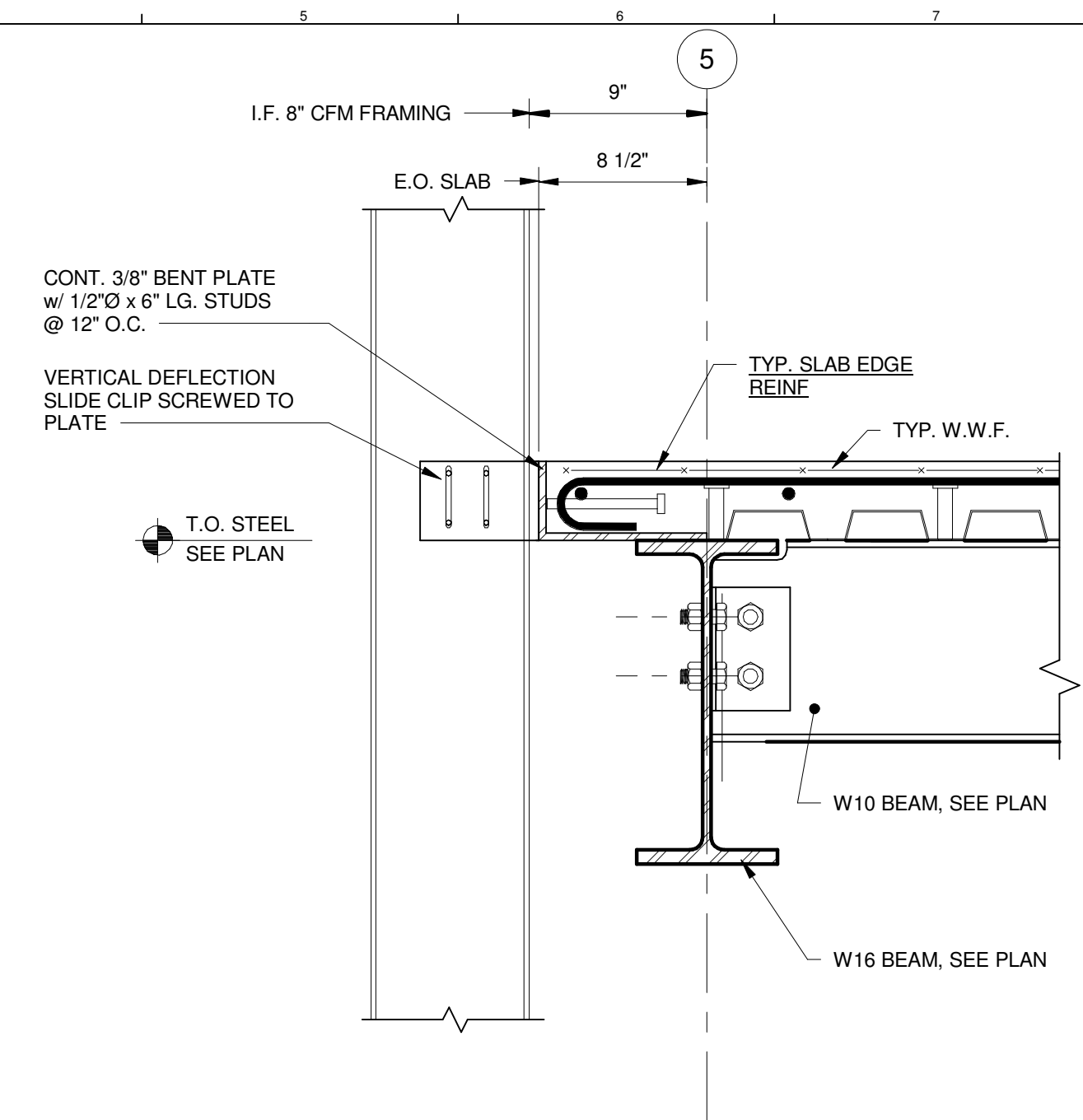

K4 SECTION
1 1/2" = 1'-0"

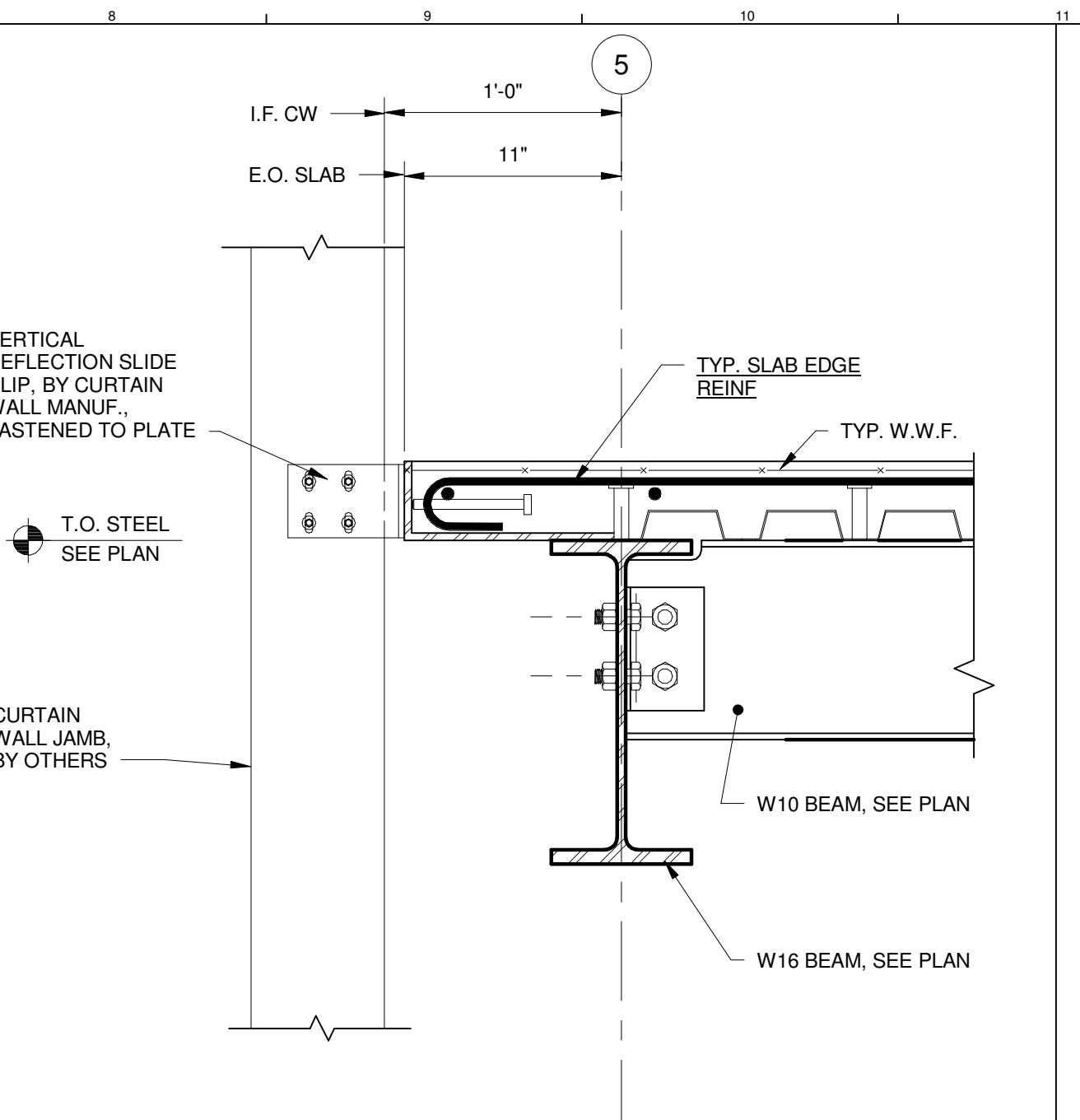

K8 SECTION
1 1/2" = 1'-0"

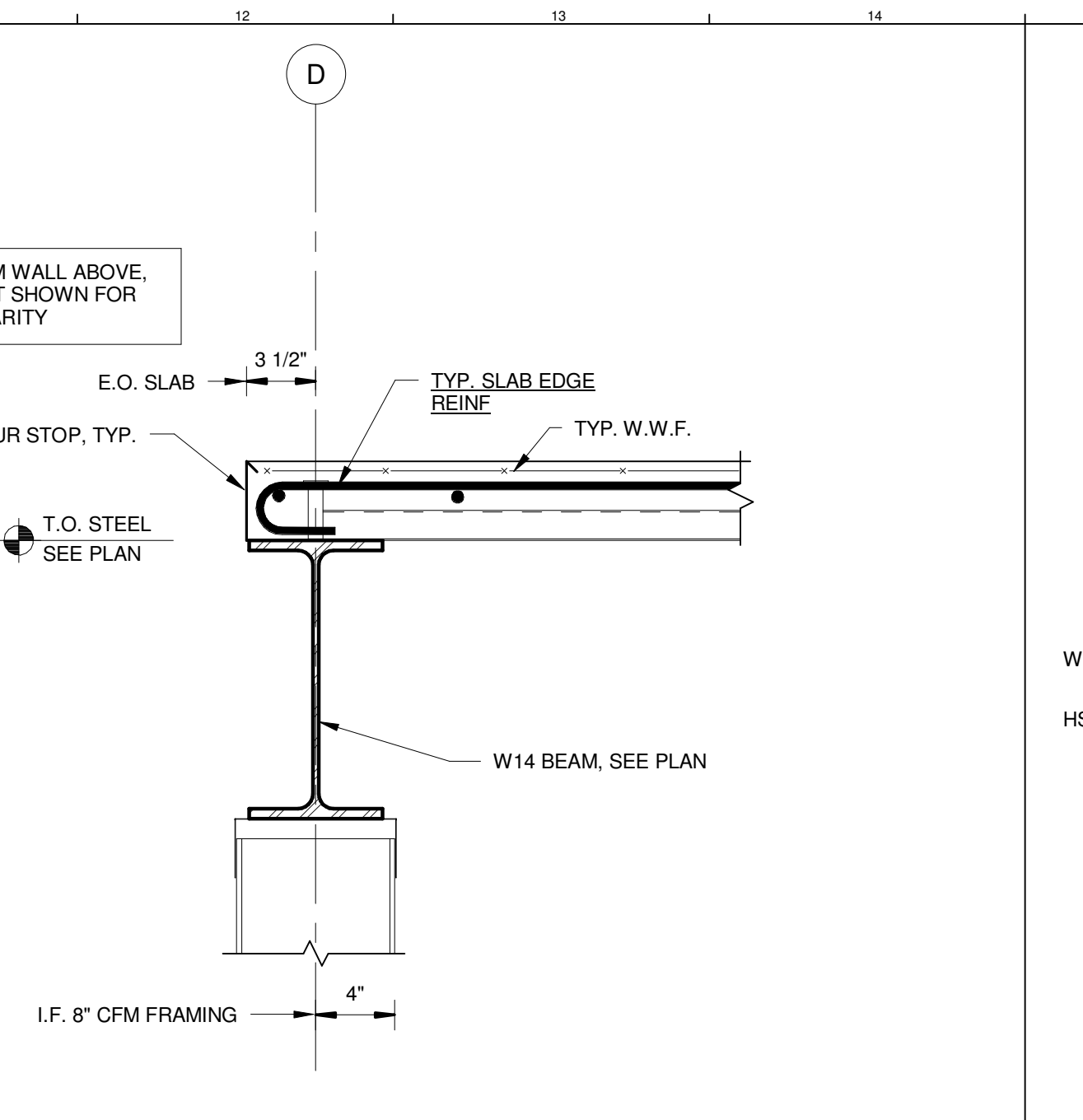

K11 SECTION
1 1/2" = 1'-0"

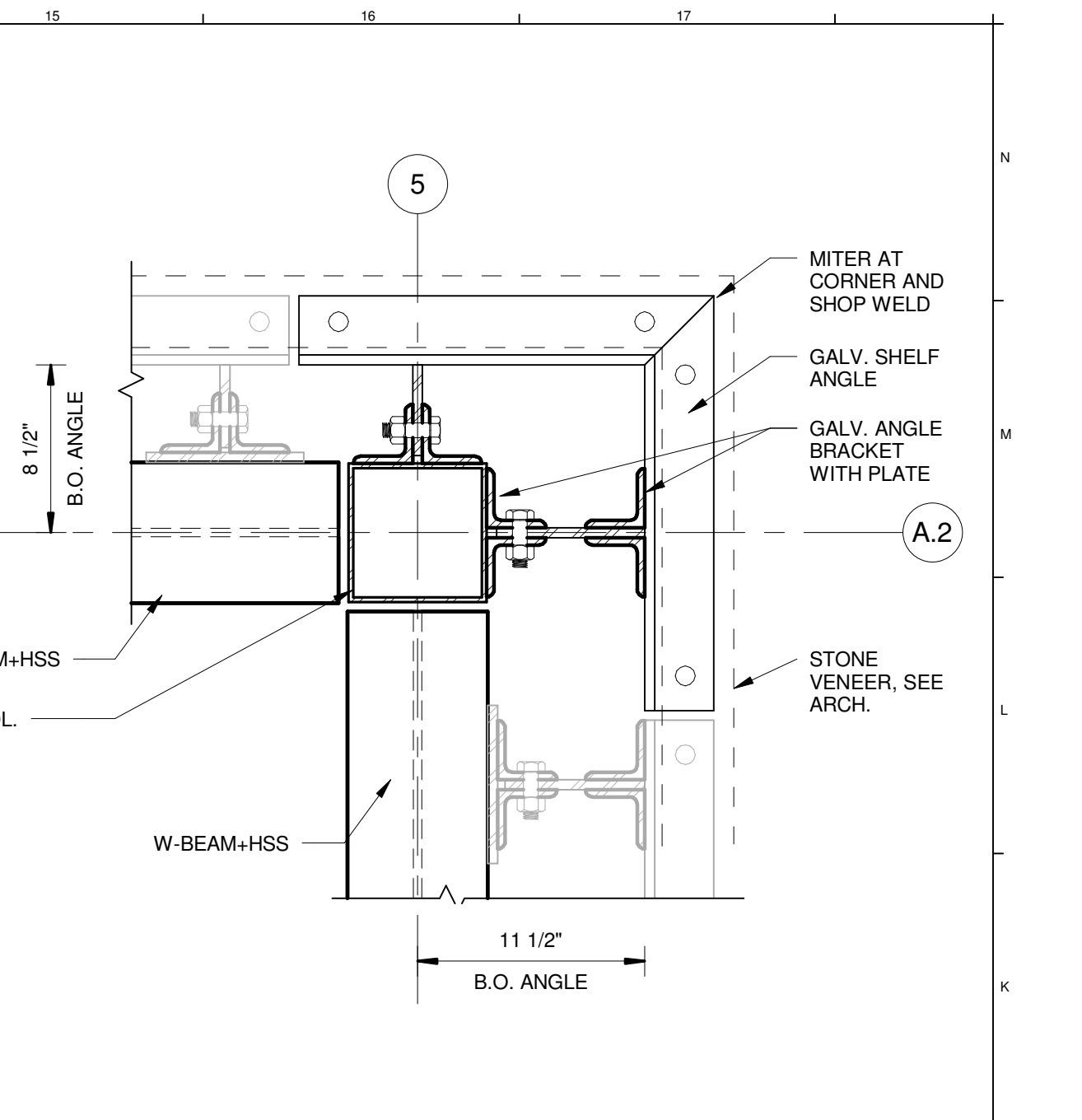

K14 PLAN DETAIL
1 1/2" = 1'-0"

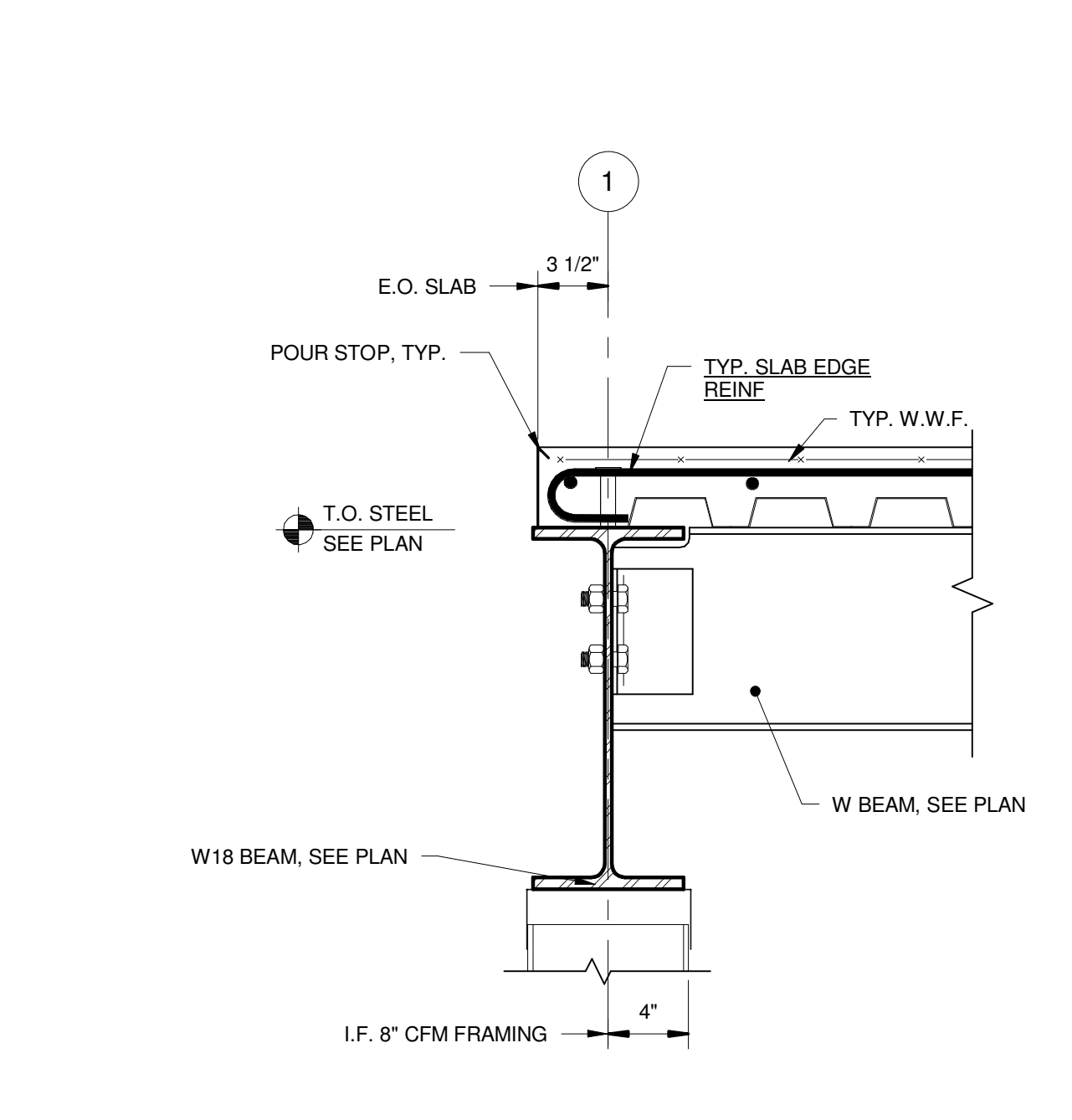

E1 SECTION
1 1/2" = 1'-0"

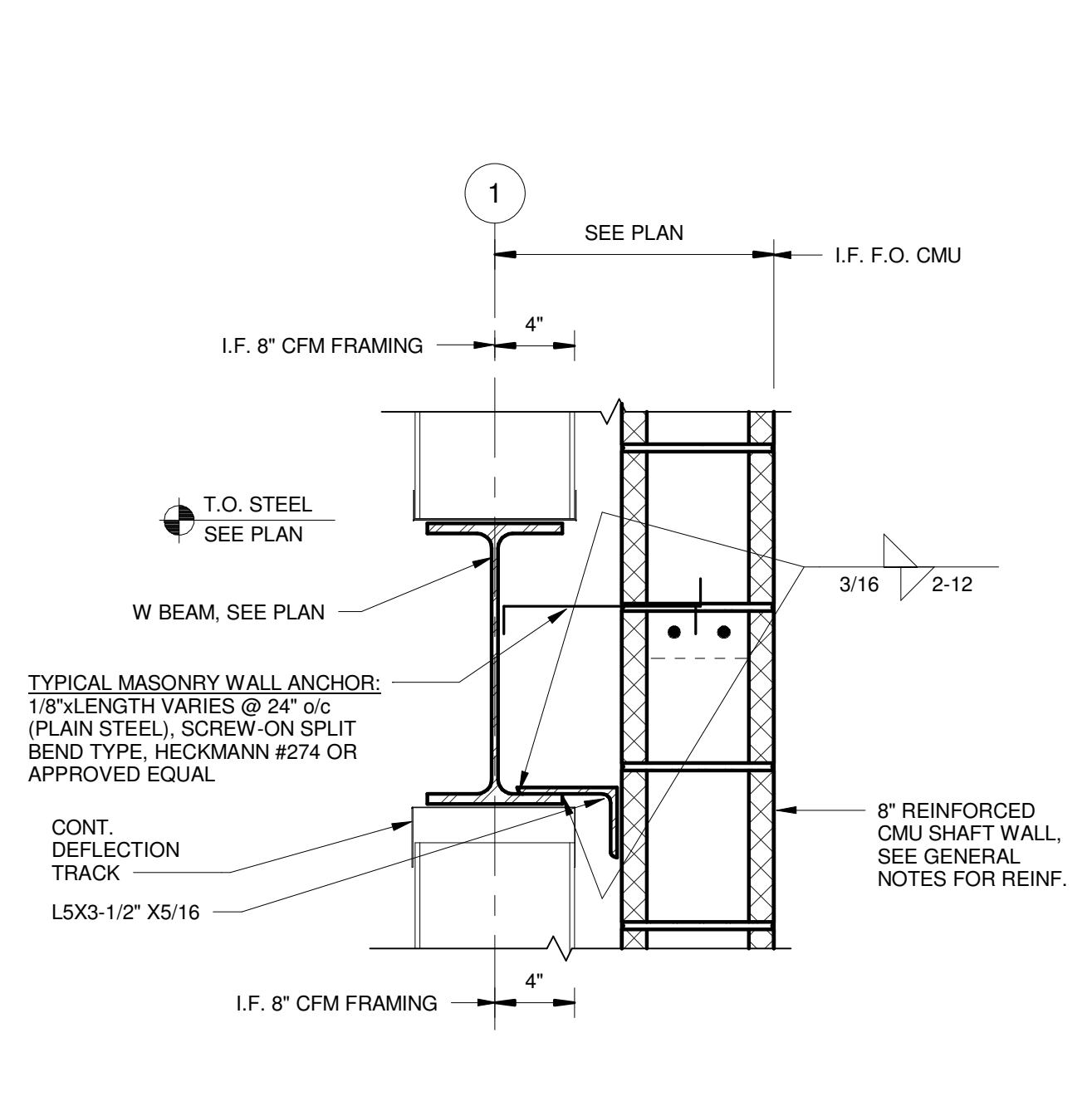

E4 SECTION
1 1/2" = 1'-0"

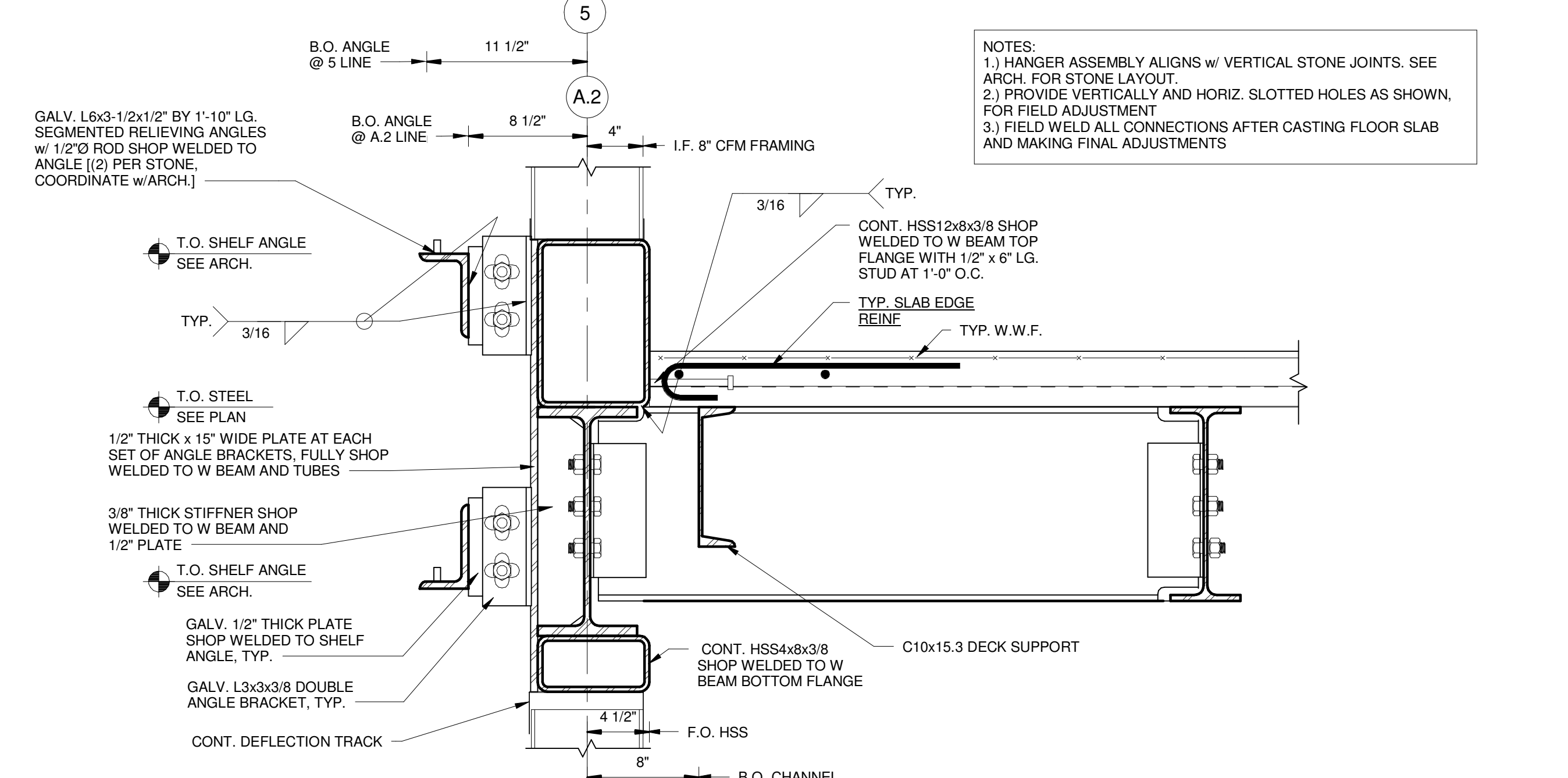

E8 SECTION
1 1/2" = 1'-0"

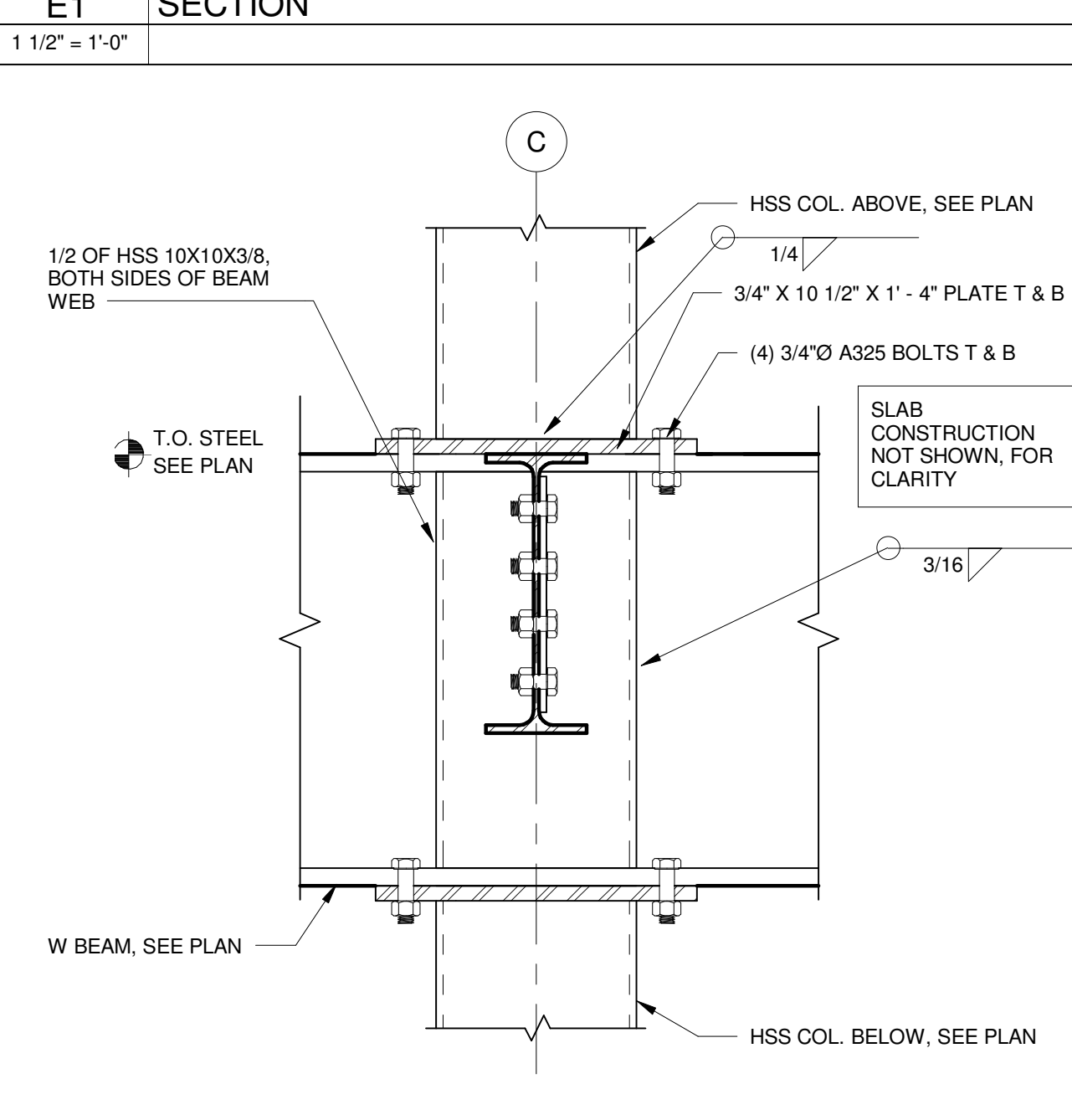
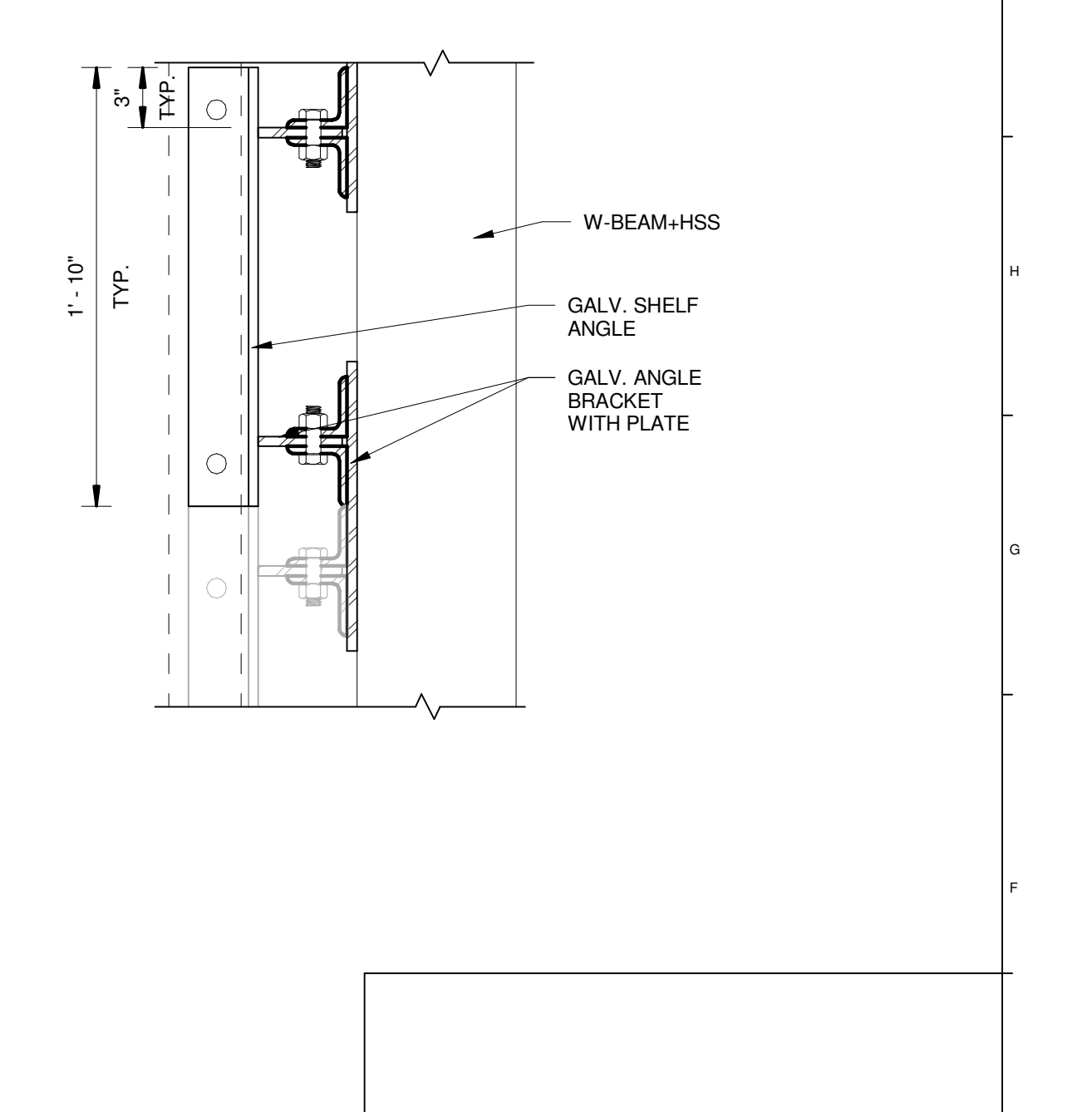

A1 SECTION
1 1/2" = 1'-0"

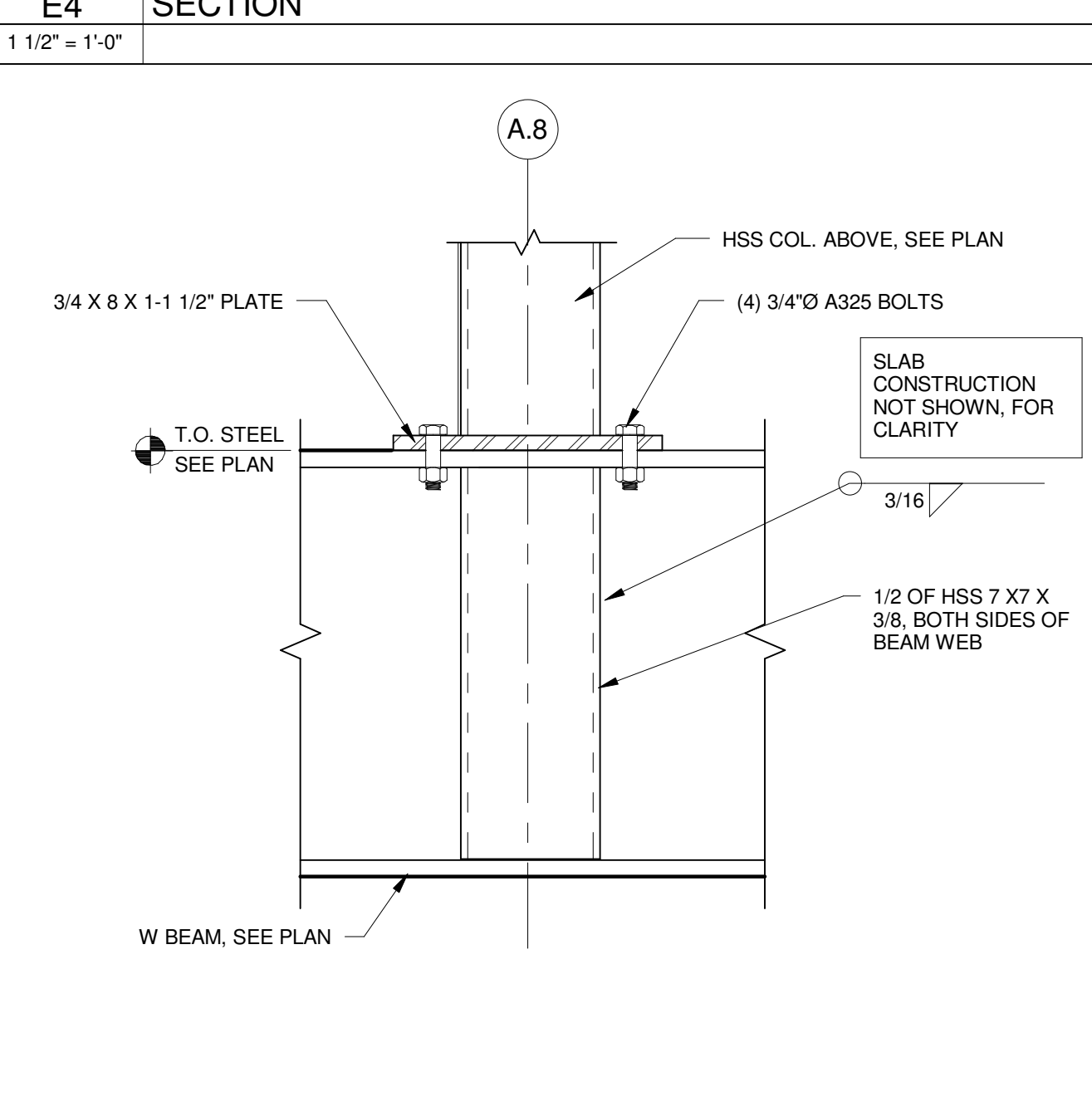

A4 SECTION
1 1/2" = 1'-0"

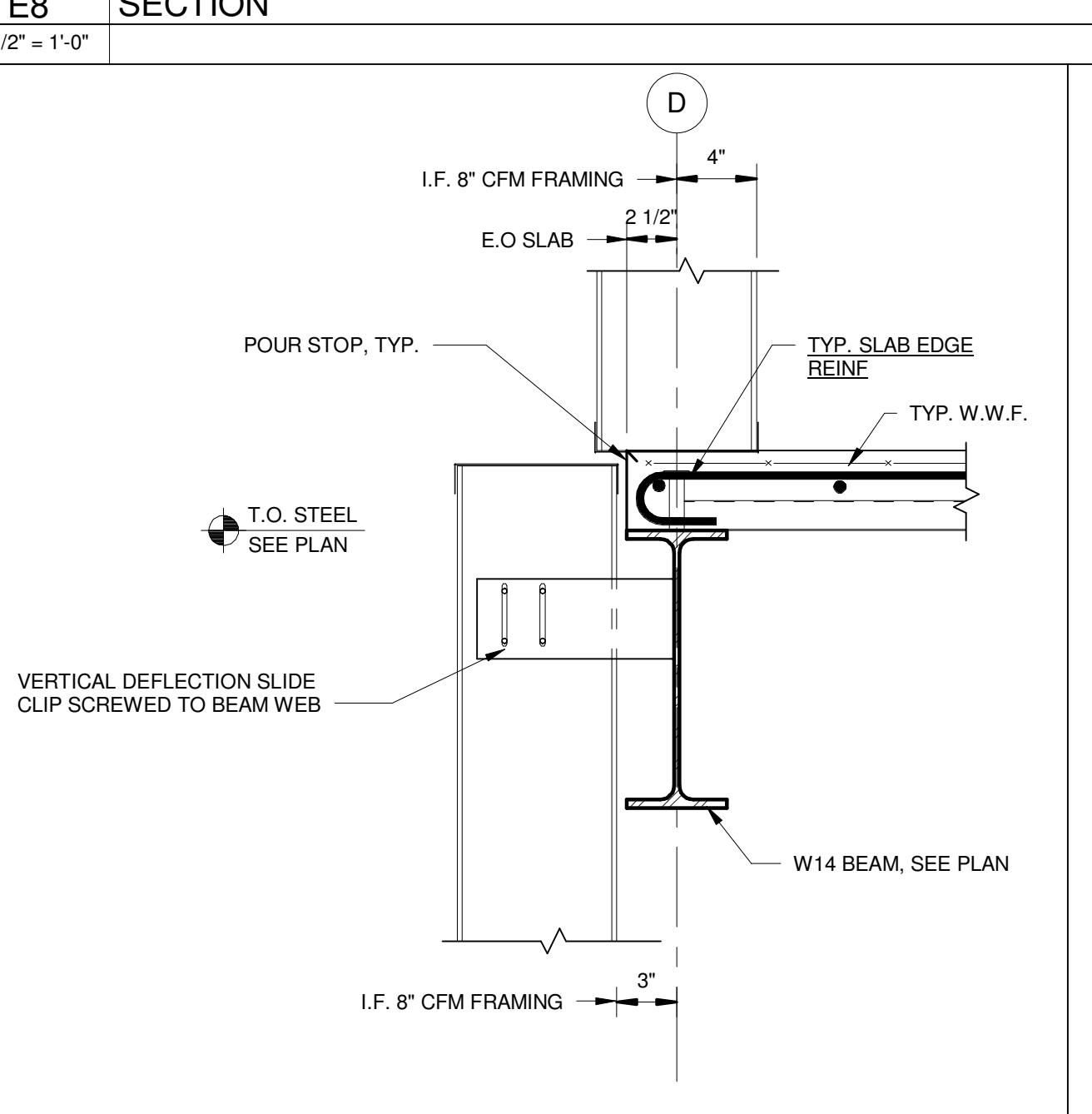

A8 SECTION
1 1/2" = 1'-0"



A8 SECTION
1 1/2" = 1'-0"

NOTES:
1.) HANGER ASSEMBLY ALIGNS w/ VERTICAL STONE JOINTS. SEE ARCH. FOR STONE LAYOUT.
2.) PROVIDE VERTICALLY AND HORIZ. SLOTTED HOLES AS SHOWN, FOR FIELD ADJUSTMENT
3.) FIELD WELD ALL CONNECTIONS AFTER CASTING FLOOR SLAB AND MAKING FINAL ADJUSTMENTS

0	ISSUED FOR BID	06 JUNE 2016
REV.	DESCRIPTION	DATE
ASYLUM PROJECT:		
FRAMING SECTIONS AND DETAILS		
SHEET TITLE:		
WBRC CAD FILE: C:\Users\jcurley\Documents\40710 - ASYLUM DANCE CLUB - STRUCT_30606.rvt		
PROJECT No: 4071.10		GRAPHIC SCALE: 0" = 1'
SCALE: 1 1/2" = 1'-0"		
PROJECT MANAGER: JRB		SHEET No:
DRAWN BY: ADG/RAD/JHW		S-505
CHECKED BY: JPC		