

H1 204 MEN'S RESTROOM
1/2" = 1'-0"

H8 204 - MENS RESTROOM - NORTH
1/4" = 1'-0"

H11 204 - MENS RESTROOM - SOUTH
1/4" = 1'-0"

H14 204 - MENS RESTROOM - WEST
1/4" = 1'-0"

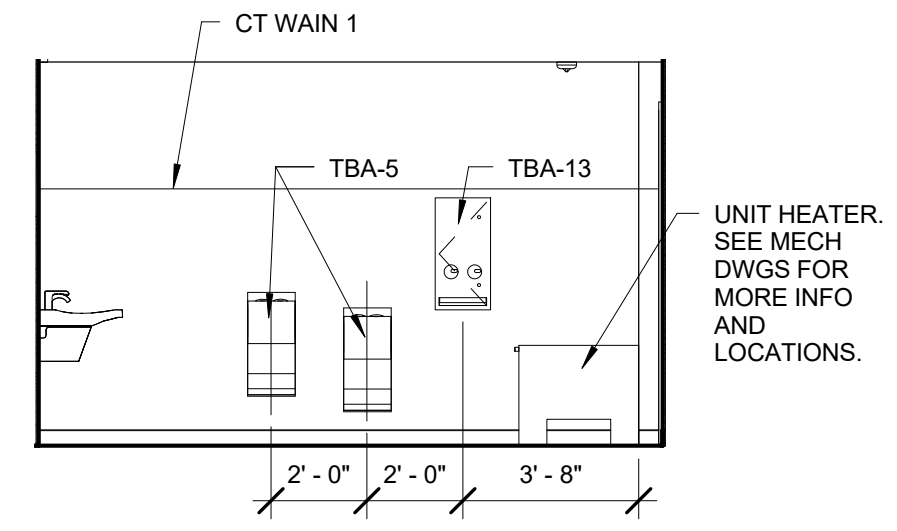
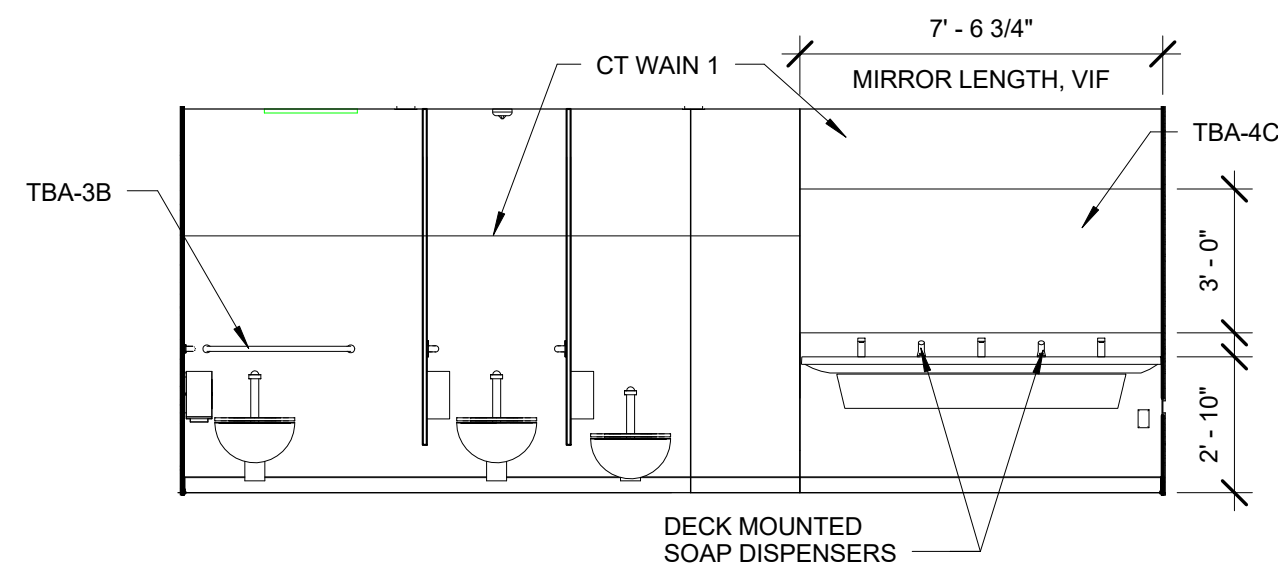
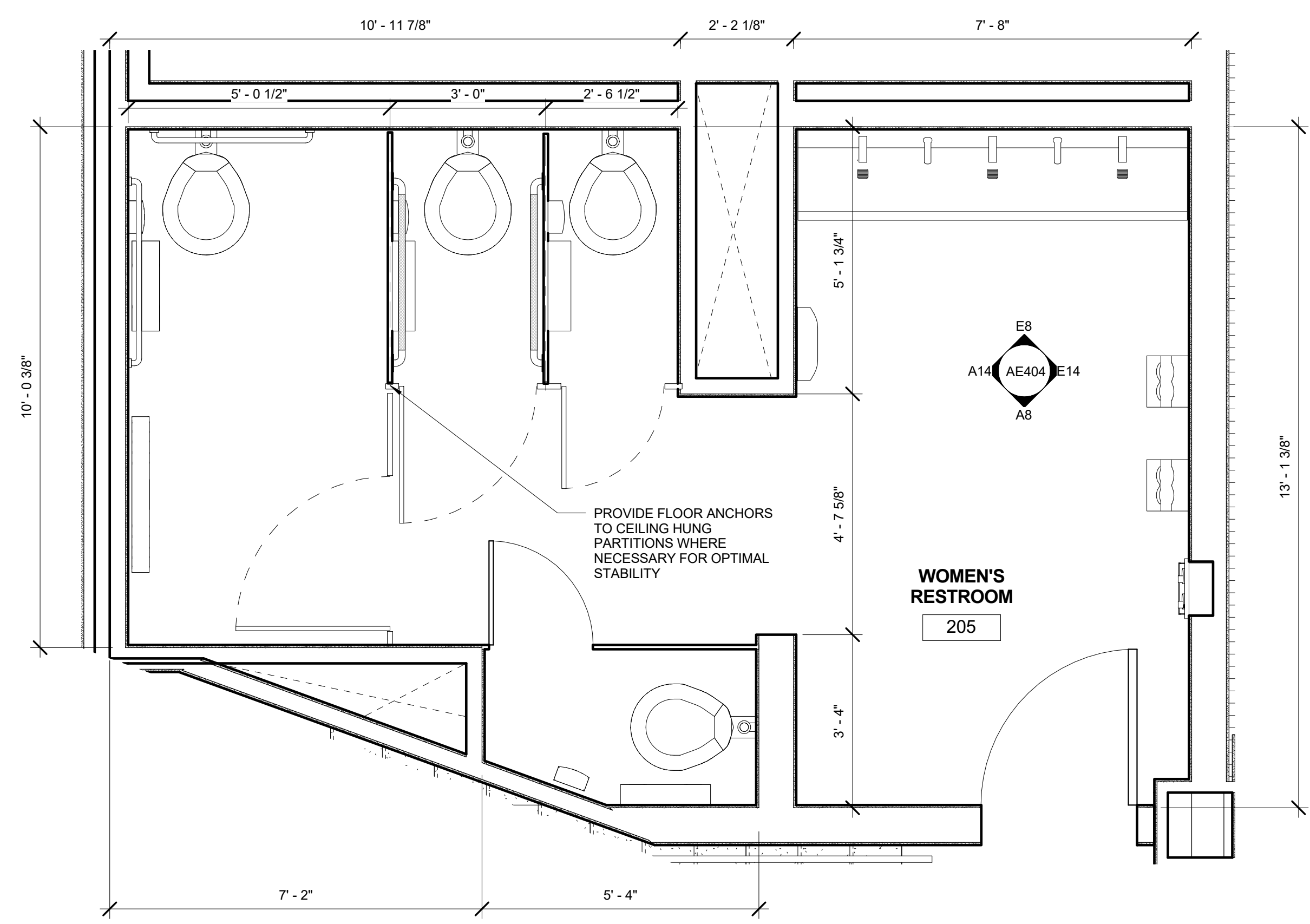

A1 205 WOMEN'S RESTROOM
1/2" = 1'-0"

A8 205 - WOMENS RESTROOM - SOUTH
1/4" = 1'-0"

A14 205 - WOMENS RESTROOM - WEST
1/4" = 1'-0"
AE404

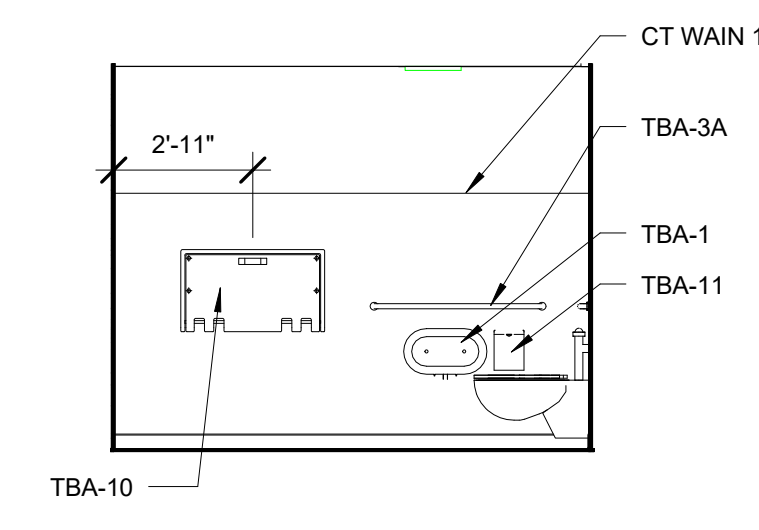
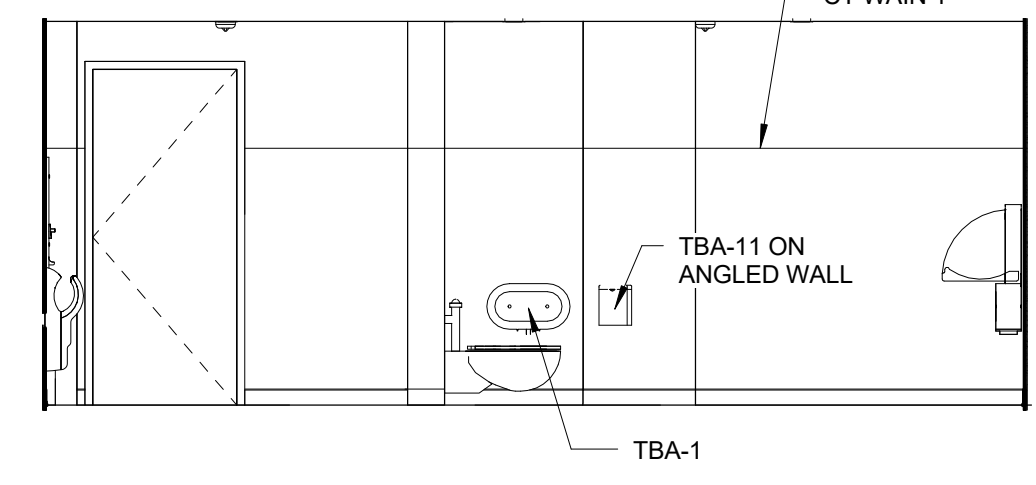

- GENERAL INTERIOR ELEVATION NOTES:**
- REFER TO ARCHITECTURAL ABBREVIATIONS ON SHEET G1002 FOR ALL ABBREVIATIONS.
 - REFER TO H1/AE401 FOR TYPICAL TOILET AND BATH ACCESSORIES (TBA) LEGEND AND MOUNTING HEIGHT INFORMATION.
 - G.C. SHALL PROVIDE AND INSTALL BLOCKING STIFFENERS, BACKING PLATES AND SUPPORTING CASEWORK (BOTH CONTRACTOR AND OWNER SUPPLIED), TOILET ACCESSORIES, VISUAL DISPLAY UNITS AND MISCELLANEOUS EQUIPMENT WHETHER SUCH SUPPORTS ARE SHOWN OR NOT. G.C. TO COORDINATE BLOCKING REQUIREMENTS OF OWNER SUPPLIED ITEMS WITH THE OWNER.
 - REFER TO AE601 FOR ALL DOOR TYPES, STYLE AND FRAME STYLES.
 - ALL EQUIPMENT, CASEWORK, ETC. TO BE CS/CI, UNO.
 - REFER TO DIVISION 6 SPECIFICATION FOR DETAILED INFORMATION RELATED TO MILLWORK WOOD CABINETS, UNO.
 - "CJ" DENOTES GWB CONTROL JOINT LOCATIONS.
 - REFER TO FINISH PLANS FOR CORNER GUARD LOCATIONS.
 - REFER TO FINISH PLANS AND SCHEDULES FOR COUNTERTOP MATERIAL.
 - REFER TO AE405 FOR CT TILE PATTERNS.
 - VERIFY ALL TOILET PARTITION DIMENSIONS IN THE FIELD BEFORE FABRICATION.

REV.	DESCRIPTION	DATE
0	ISSUED FOR CONSTRUCTION	06 JUNE 2016

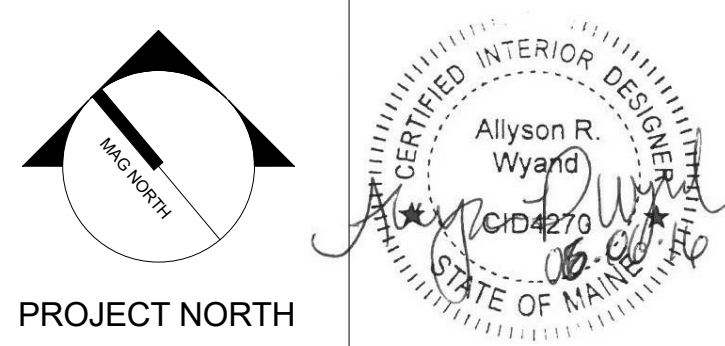

WBRC
ARCHITECTS ENGINEERS
WWW.WBRCAE.COM
BANGOR, MAINE 207-947-4511
PORTLAND, MAINE 207-528-4511
SARASOTA, FLORIDA 941-556-0757

ASYLUM
PROJECT:
ENLARGED RESTROOM PLANS & ELEVATIONS

SHEET TITLE:

WBRC CAD FILE: C:\Users\jpcyln\Documents\407110 - ASYLUM DANCE CLUB - ARCH_jpcyln.boothie.rvt

PROJECT No: 4071.10	GRAPHIC SCALE: 0" = 1'
SCALE: As Indicated	SHEET No:
PROJECT MANAGER: JRB	DRAWN BY: ARW
CHECKED BY: JLR	AE404

6/7/2016 8:39:02 AM C:\Users\jpcyln\Documents\407110 - ASYLUM DANCE CLUB - ARCH_jpcyln.boothie.rvt