

DISPLAY THIS CARD ON PRINCIPAL FRONTAGE OF WORK
CITY OF PORTLAND

Please Read
Application And
Notes, If Any,
Attached

BUILDING INSPECTION

PERMIT

Permit Number: 070053

This is to certify that CITY OF PORTLAND /City of Portland /Trades Division

has permission to Tenant fit-up MIS -Conferen room & rec

AT 389 CONGRESS ST

L 027 C012001

PERMIT ISSUED

provided that the person or persons who apply for and accept this permit shall comply with all of the provisions of the Statutes of the State and of the Ordinances of the City of Portland regulating the construction, maintenance and use of buildings and structures, and of the application on file in this department.

Apply to Public Works for street line and grade if nature of work requires such information.

Classification of inspection must be given and when permission is procured before this building or part thereof is occupied or service is closed-in. 4
 YOUR NOTICE IS REQUIRED.

A certificate of occupancy must be procured by owner before this building or part thereof is occupied.

OTHER REQUIRED APPROVALS

Fire Dept. Jay Kelley, P.F.D. 01/18/07

Health Dept. _____

Appeal Board _____

Other _____

Department Name

Thomas M. Markley 3/13/07
 Director - Building & Inspection Services

PENALTY FOR REMOVING THIS CARD

City of Portland, Maine - Building or Use Permit Application

389 Congress Street, 04101 Tel: (207) 874-8703, Fax: (207) 874-8716

Permit No: 07-0053	Issue Date:	CBL: 027 C012001
-----------------------	-------------	---------------------

Location of Construction: 389 CONGRESS ST	Owner Name: CITY OF PORTLAND	Owner Address: 389 CONGRESS ST	Phone:
Business Name:	Contractor Name: City of Portland /Trades Division	Contractor Address:	Phone:
Lessee/Buyer's Name	Phone:	Permit Type: Alterations - Commercial	Zone: B-3

Past Use: City Hall	Proposed Use: City Hall - Tenant fit-up MIS - Conference room & Office space	Permit Fee: \$120.00	Cost of Work: \$10,000.00	CEO District: 1
------------------------	--	-------------------------	------------------------------	--------------------

Proposed Project Description: Tenant fit-up MIS -Conference room & Office space	FIRE DEPT: <input checked="" type="checkbox"/> Approved <input type="checkbox"/> Denied	INSPECTION: Use Group: <i>Assembly type SB</i> <i>IBC 2003</i>
	Signature: <i>JK PFD 01/18/07</i>	Signature: <i>Jm 3/13/07</i>

PEDESTRIAN ACTIVITIES DISTRICT (P.A.D.)		
Action: <input type="checkbox"/> Approved <input type="checkbox"/> Approved w/Conditions <input type="checkbox"/> Denied	Signature: _____ Date: _____	

Permit Taken By: Idobson	Date Applied For: 01/16/2007	Zoning Approval		
-----------------------------	---------------------------------	------------------------	--	--

<ol style="list-style-type: none"> This permit application does not preclude the Applicant(s) from meeting applicable State and Federal Rules. Building permits do not include plumbing, septic or electrical work. Building permits are void if work is not started within six (6) months of the date of issuance. False information may invalidate a building permit and stop all work.. 	Special Zone or Reviews <input type="checkbox"/> Shoreland <input type="checkbox"/> Wetland <input type="checkbox"/> Flood Zone <input type="checkbox"/> Subdivision <input type="checkbox"/> Site Plan Maj <input type="checkbox"/> Minor <input type="checkbox"/> MM <input type="checkbox"/> Date: <i>1/16/07</i>	Zoning Appeal <input type="checkbox"/> Variance <input type="checkbox"/> Miscellaneous <input type="checkbox"/> Conditional Use <input type="checkbox"/> Interpretation <input type="checkbox"/> Approved <input type="checkbox"/> Denied Date: _____	Historic Preservation <input type="checkbox"/> Not in District or Landmark <input type="checkbox"/> Does Not Require Review <input type="checkbox"/> Requires Review <input type="checkbox"/> Approved <input type="checkbox"/> Approved w/Conditions <input type="checkbox"/> Denied Date: <i>Requires A</i>
	<i>any exterior work</i> <i>Separate review & Approval</i>		

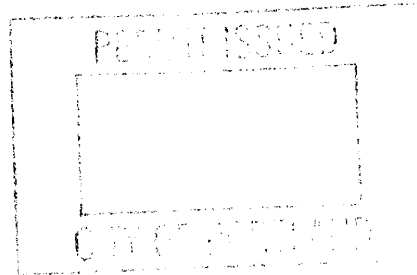

CERTIFICATION

I hereby certify that I am the owner of record of the named property, or that the proposed work is authorized by the owner of record and that I have been authorized by the owner to make this application as his authorized agent and I agree to conform to all applicable laws of this jurisdiction. In addition, if a permit for work described in the application is issued, I certify that the permit holder shall have the authority to enter all areas covered by such permit or such permit.

All Purpose Building Permit Application

If you or the property owner owes real estate or personal property taxes or user charges on any property within the City, payment arrangements must be made before permits of any kind are accepted.

Location/Address of Construction: <u>389 Congress</u>		
Total Square Footage of Proposed Structure <u>1500</u>	Square Footage of Lot	
Tax Assessor's Chart, Block & Lot Chart# <u>27</u> Block# <u>C</u> Lot# <u>12</u>	Owner: <u>CITY OF PORTLAND</u>	Telephone: <u>874-8893</u>
Lessee/Buyer's Name (If Applicable)	Applicant name, address & telephone: <u>CITY OF PORTLAND 389 CONGRESS ST PORTLAND, ME 04101</u>	Cost Of Work: <u>\$10,000.00</u> Fee: \$
Current use: <u>MIS</u>		
If the location is currently vacant, what was prior use: _____		
Approximately how long has it been vacant: _____		
Proposed use: <u>SAME - UPGRADING MECHANICALS, BUILDING</u>		
Project description: <u>A CONFERENCE ROOM/OFFICE SPACE</u>		
Contractor's name, address & telephone: <u>CITY OF PORTLAND (TRADES DIVISION)</u>		
Who should we contact when the permit is ready: <u>KATHY HINES 874-8893</u>		
Mailing address:		
We will contact you by phone when the permit is ready. You must come in and pick up the permit and review the requirements before starting any work, with a Plan Reviewer. A stop work order will be issued and a \$100.00 fee if any work starts before the permit is picked up. PHONE:		

IF THE REQUIRED INFORMATION IS NOT INCLUDED IN THE SUBMISSIONS THE PERMIT WILL BE AUTOMATICALLY DENIED AT THE DISCRETION OF THE BUILDING/PLANNING DEPARTMENT, WE MAY REQUIRE ADDITIONAL INFORMATION IN ORDER TO APPROVE THIS PERMIT.

I hereby certify that I am the Owner of record of the named property, or that the owner of record authorizes the proposed work and that I have been authorized by the owner to make this application as his/her authorized agent. I agree to conform to all applicable laws of this jurisdiction. In addition, if a permit for work described in this application is issued, I certify that the Code Official's authorized representative shall have the authority to enter all areas covered by this permit at any reasonable hour to enforce the provisions of the codes applicable to this permit.

Signature of applicant: <u>[Signature]</u>	Date: <u>1/11/07</u>
--	----------------------

This is NOT a permit, you may not commence ANY work until the permit is issued.
If you are in a Historic District you may be subject to additional permitting and fees with the Planning Department on the 4th floor of City Hall

City of Portland, Maine - Building or Use Permit

389 Congress Street, 04101 Tel: (207) 874-8703, Fax: (207) 874-8716

Permit No: 07-0053	Date Applied For: 01/16/2007	CBL: 027 C012001
------------------------------	--	----------------------------

Location of Construction: 389 CONGRESS ST	Owner Name: CITY OF PORTLAND	Owner Address: 389 CONGRESS ST	Phone:
Business Name:	Contractor Name: City of Portland /Trades Division	Contractor Address:	Phone:
Lessee/Buyer's Name	Phone:	Permit Type: Alterations - Commercial	

Proposed Use: City Hall - Tenant fit-up MIS -Conference room & Office space	Proposed Project Description: Tenant fit-up MIS -Conference room & Office space
---	---

Dept: Zoning **Status:** Approved **Reviewer:** Marge Schmuckal **Approval Date:** 01/16/2007
Note: **Ok to Issue:**

Dept: Building **Status:** Approved with Conditions **Reviewer:** Tom Markley **Approval Date:** 03/13/2007
Note: **Ok to Issue:**

- 1) Separate permits are required for any electrical, plumbing, or HVAC systems. Separate plans may need to be submitted for approval as a part of this process.
- 2) Application approval based upon information provided by applicant. Any deviation from approved plans requires separate review and approval prior to work.

Dept: Fire **Status:** Approved **Reviewer:** Jay Kelley **Approval Date:** 01/18/2007
Note: **Ok to Issue:**

- 1) approved as submitted

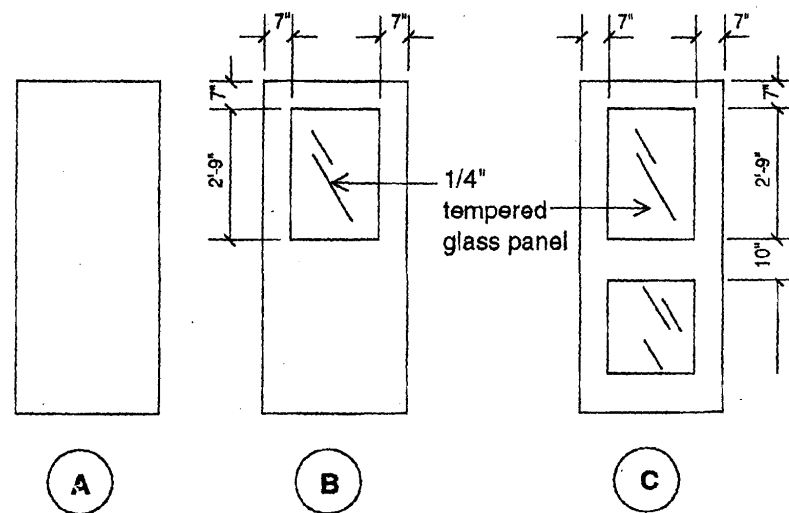

DOOR TYPES

1/4" = 1' 0"

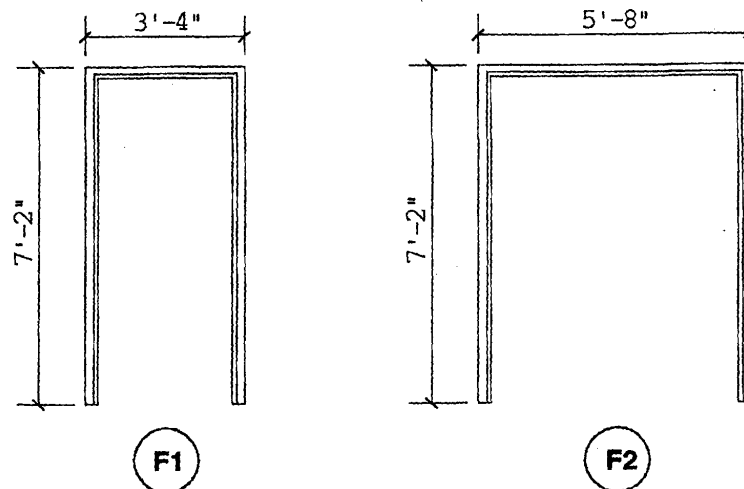

FRAME TYPES

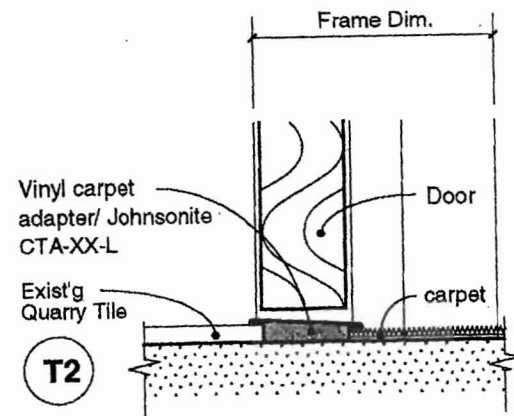
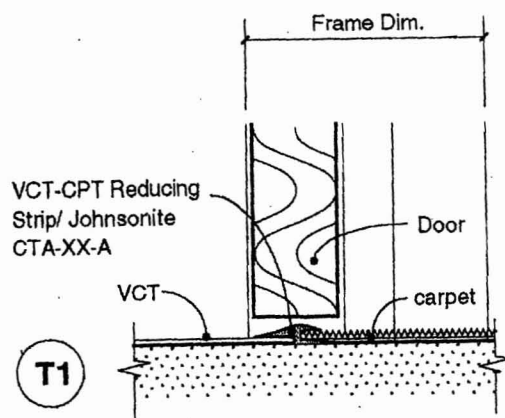
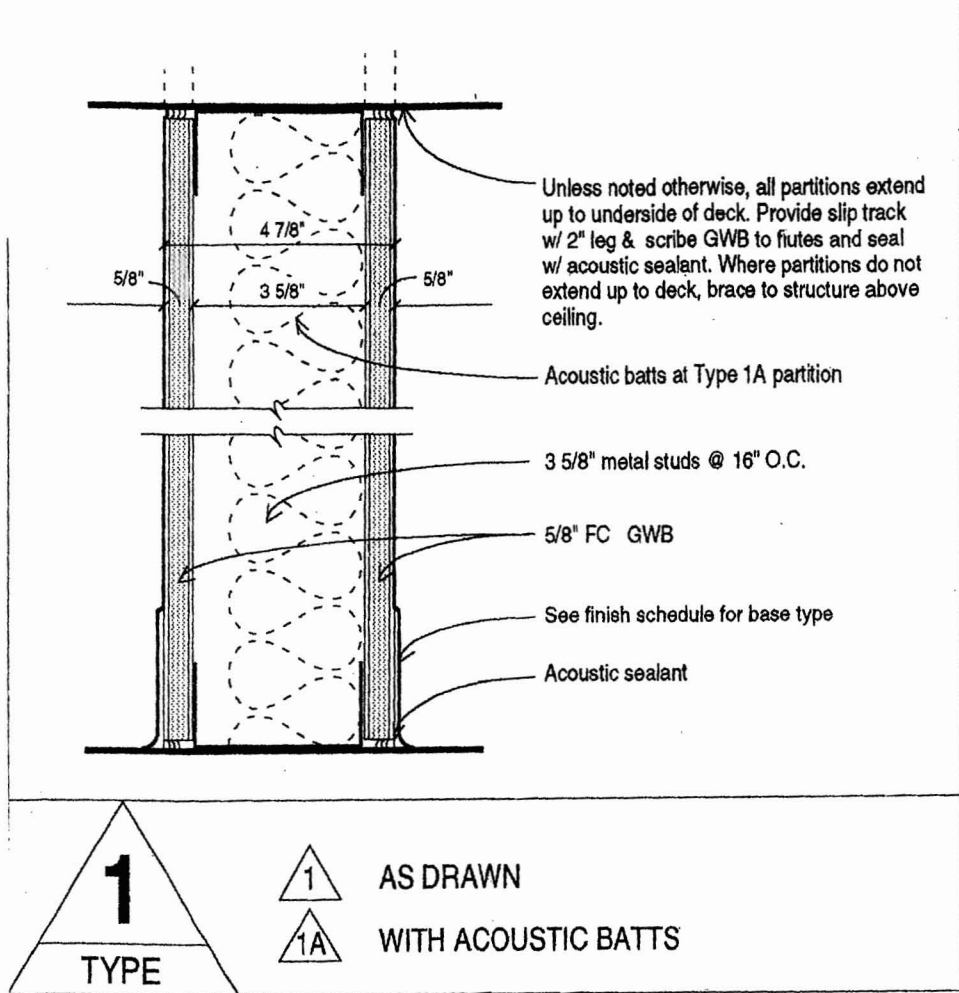

THRESHOLD TYPES