

DISPLAY THIS CARD ON PRINCIPAL FRONTAGE OF WORK

# CITY OF PORTLAND

BUILDING INSPECTION

Permit Number: 031527

Please Read Application And Notes, If Any, Attached

## PERMIT

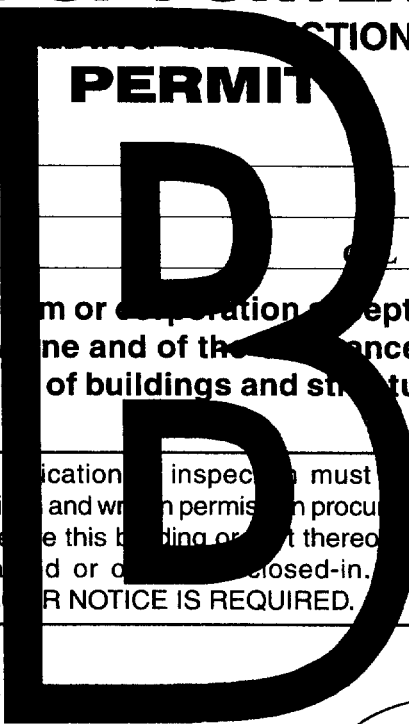

This is to certify that City Of Portland/Emmit Mead

has permission to Repair Entrance stairway

AT 389 Congress St

027 C012001

provided that the person or persons, firm or corporation accepting this permit shall comply with all of the provisions of the Statutes of Maine and of the Ordinances of the City of Portland regulating the construction, maintenance and use of buildings and structures, and of the application on file in this department.

Apply to Public Works for street line and grade if nature of work requires such information.

Notification of inspection must be given and written permission procured before this building or part thereof is laid out or closed-in. HOUR NOTICE IS REQUIRED.

A certificate of occupancy must be procured by owner before this building or part thereof is occupied.

OTHER REQUIRED APPROVALS

Fire Dept. [Signature]  
Health Dept. \_\_\_\_\_  
Appeal Board \_\_\_\_\_  
Other \_\_\_\_\_  
Department Name

[Signature] 10/5/03  
Director - Building & Inspection Services

PENALTY FOR REMOVING THIS CARD

9/29/05

done.

AR

**City of Portland, Maine - Building or Use Permit Application**

389 Congress Street, 04101 Tel: (207) 874-8703, Fax: (207) 874-8716

Permit No: 03-1527	Issue Date:	CBL: 027 C012001
-----------------------	-------------	---------------------

Location of Construction: 389 Congress St	Dwner Name: City Of Portland	Owner Address: 389 Congress St	Phone:
Business Name: n/a	Contractor Name: Emmit Mead	Contractor Address: Portland	Phone
Lessee/Buyer's Name n./a	Phone: n/a	Permit Type: Alterations - Commercial	Zone: B3

Past Use: Public Building / City Hall	Proposed Use: City Hall / Repair entrance stairway	CEO District: \$0.00
Proposed Project Description: Repair Entrance stairway - interior basement stairs on chestnut St. side		FIRE DEPT: Approved INSPECTION: Use Group: B Type: 30 12/31/03 Signature: <i>umm</i> Signature: <i>[Signature]</i>

PEDESTRIAN ACTIVITIES DISTRICT (P.A.D.)	
Action: <input type="checkbox"/> Approved <input type="checkbox"/> Approved w/Conditions <input type="checkbox"/> Denied	Signature: _____ Date: _____

Permit Taken By: gg	Date Applied For: 12/19/2003	<b>Zoning Approval</b>
------------------------	---------------------------------	------------------------

Special Zone or Reviews	Zoning Appeal	Historic Preservation
<input type="checkbox"/> Shoreland	<input type="checkbox"/> Variance	<input type="checkbox"/> Not in District or Landmar
<input type="checkbox"/> Wetland	<input type="checkbox"/> Miscellaneous	<input type="checkbox"/> Does Not Require Review
<input type="checkbox"/> Flood Zone	<input type="checkbox"/> Conditional Use	<input type="checkbox"/> Requires Review
<input type="checkbox"/> Subdivision	<input type="checkbox"/> Interpretation	<input type="checkbox"/> Approved
<input type="checkbox"/> Site Plan	<input type="checkbox"/> Approved	<input type="checkbox"/> Approved w/Conditions
Maj <input type="checkbox"/> Minor <input type="checkbox"/> MM <input type="checkbox"/>	<input type="checkbox"/> Denied	<input type="checkbox"/> Denied
Date: <i>ok</i> 12/24/03	Date: _____	Date: <i>my exterior work requires a sep. review</i>

**CERTIFICATION**

I hereby certify that I am the owner of record of the named property, or that the proposed work is authorized by the owner of record and that I have been authorized by the owner to make this application as his authorized agent and I agree to conform to all applicable laws of this jurisdiction. In addition, if a permit for work described in the application is issued, I certify that the code official's authorized representative shall have the authority to enter all areas covered by such permit at any reasonable hour to enforce the provision of the code(s) applicable to such permit.

SIGNATURE OF APPLICANT	ADDRESS	DATE	PHONE
RESPONSIBLE PERSON IN CHARGE OF WORK, TITLE		DATE	PHONE

**City of Portland, Maine - Building or Use Permit**

389 Congress Street, 04101 Tel: (207) 874-8703, Fax: (207) 874-8716

<b>Permit No:</b> 03-1527	<b>Date Applied For:</b> 12/19/2003	<b>CBL:</b> 027 C012001
------------------------------	--	----------------------------

<b>Location of Construction:</b> 389 Congress St	<b>Owner Name:</b> City Of Portland	<b>Owner Address:</b> 389 Congress St	<b>Phone:</b>
<b>Business Name:</b> n/a	<b>Contractor Name:</b> Emmit Mead	<b>Contractor Address:</b> Portland	<b>Phone:</b>
<b>Lessee/Buyer's Name:</b> n/a	<b>Phone:</b> n/a	<b>Permit Type:</b> Alterations - Commercial	

<b>Proposed Use:</b> City Hall / Repair entrance stairway- interior basement stairs on Chestnut St. Side	<b>Proposed Project Description:</b> Repair Entrance stairway
---	--

--

**Dept:** Building      **Status:** Approved      **Reviewer:** Mike Nugent      **Approval Date:** 12/31/2003  
**Note:**      **Ok to Issue:**

**Dept:** Fire      **Status:** Approved      **Reviewer:** Lt. MacDougal      **Approval Date:** 12/24/2003  
**Note:**      **Ok to Issue:**

# All Purpose Building Permit Application

If you or the property owner owes real estate or personal property taxes or user charges on any property within the City, payment arrangements must be made before permits of any kind are accepted.

Location/Address of Construction: <u>389 Congress St.</u>		
Total Square Footage of Proposed Structure	Square Footage of Lot	
Tax Assessor's Chart, Block & Lot Chart# <u>020</u> Block# <u>C</u> Lot# <u>012</u>	Owner: <u>CITY of PORTLAND</u>	Telephone: <u>874-8895</u>
Lessee/Buyer's Name (if Applicable)	Applicant name, address & telephone: <u>PUBLIC BUILDINGS</u>	Cost Of Work: \$ <u>500</u> Fee: \$
Current use: <u>Entrance Stairway</u>		
If the location is currently vacant, what was prior use: <u>N/A</u>		
Approximately how long has it been vacant: _____		
Proposed use: _____		
Project description: _____		
Contractor's name, address & telephone: <u>EMMETT MEAD</u>		
Who should we contact when the permit is ready: <u>EMMETT MEAD</u>		
Mailing address: _____		
<p>We will contact you by phone when the permit is ready, You must come in and pick up the permit and review the requirements before starting any work, with a Plan Reviewer. A stop work order will be issued and a \$100.00 fee if any work starts before the permit is picked up. PHONE: <u>874-8895</u></p>		

IF THE REQUIRED INFORMATION IS NOT INCLUDED IN THE SUBMISSIONS THE PERMIT WILL BE AUTOMATICALLY DENIED AT THE DISCRETION OF THE BUILDING/PLANNING DEPARTMENT, WE MAY REQUIRE ADDITIONAL INFORMATION IN ORDER TO APPROVE THIS PERMIT.

I hereby certify that I am the Owner of record of the named property, or that the owner of record authorizes the proposed work and that I have been authorized by the owner to make this application as his/her authorized agent. I agree to conform to all applicable laws of this jurisdiction. In addition, if a permit for work described in this application is issued, I certify that the Code Official's authorized representative shall have the authority to enter all areas covered by this permit at any reasonable hour to enforce the provisions of the codes applicable to this permit.

Signature of applicant: <u>Emmett Mead</u>	Date: <u>12/12/03</u>
--	-----------------------

This is NOT a permit, you may not commence ANY work until the permit is issued. If you are in a Historic District you may be subject to additional permitting and fees with the Planning Department on the 4<sup>th</sup> floor of City Hall.

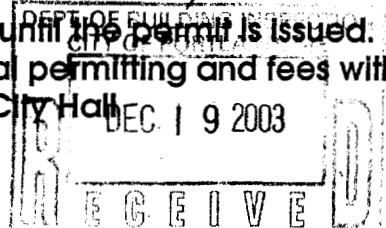

CITY OF PORTLAND, MAINE

Facilities Management  
389 Congress Street  
Portland, Maine 04101  
(207) 874-8292



JOB City hall STAIRS  
CALCULATED BY \_\_\_\_\_ DATE \_\_\_\_\_  
SCALE 3/8" = 1 Ft.

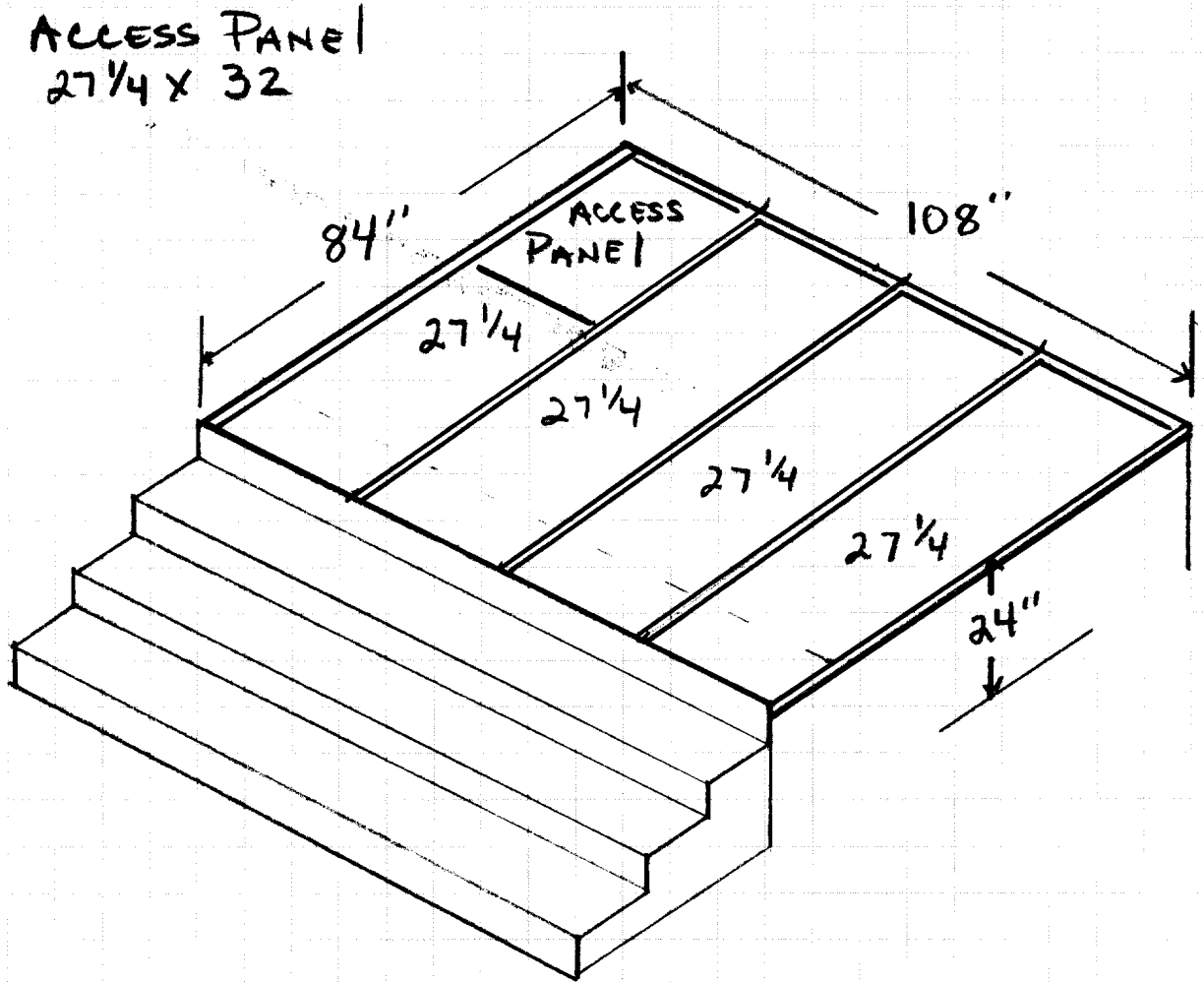

TOP PLATFORM  
1/4" x 1 3/4" ANGLE STEEL  
FILLED WITH AC PLY.

STAIR 6" RISERS  
1 1/2" TREADS  
2x12 & 2x6  
PINE CONSTRUCTION