

T:\00\_TFH Projects\022\_Chestnut Street\Construction Documents\05-Detail\02-Plan\Detail A5.0.rvt, 2/24/2008 10:25:11 AM, HP DesignJet 760C Plus (E...\_A5.0.rvt

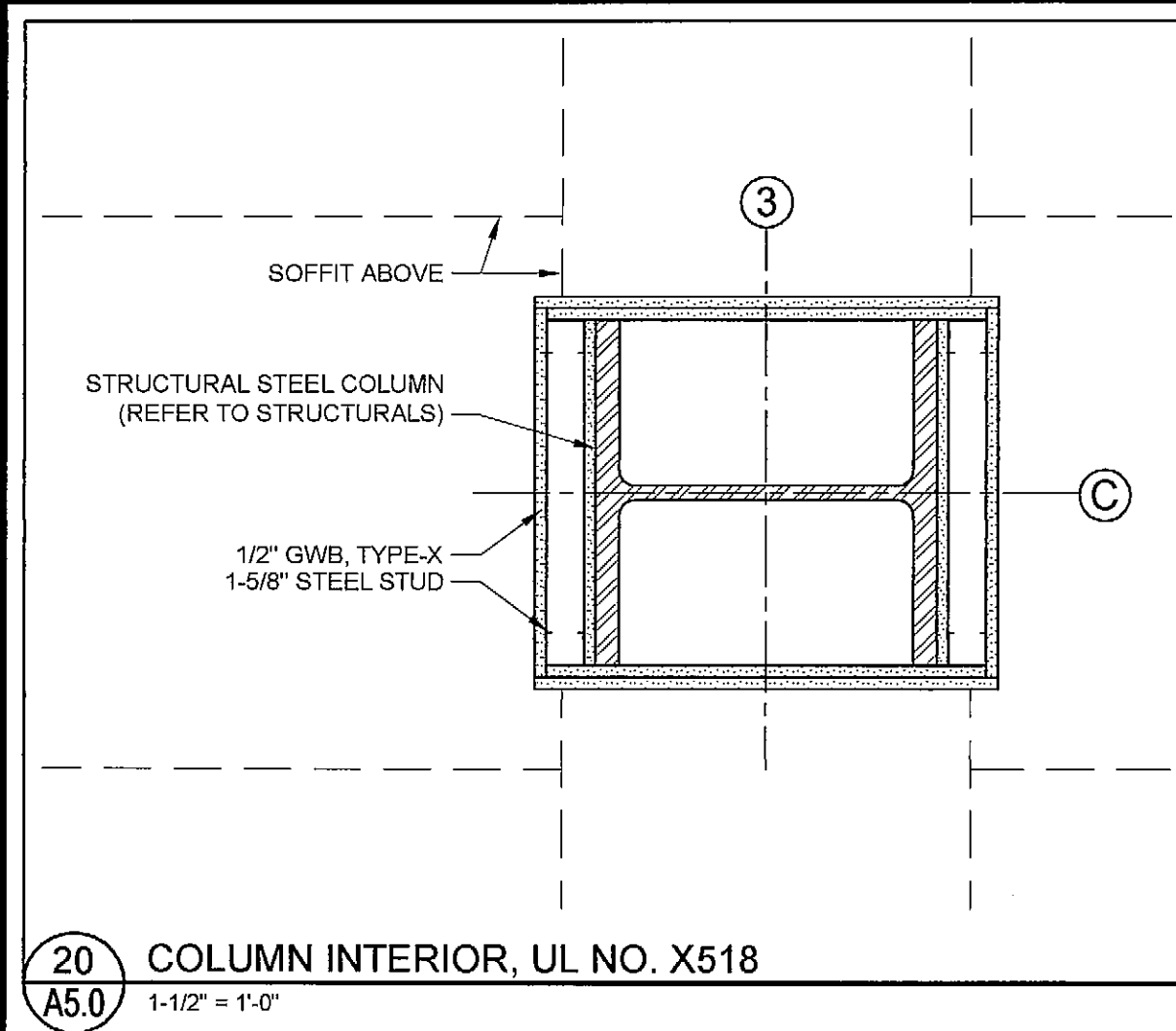

20 COLUMN INTERIOR, UL NO. X518  
A5.0 1-1/2" = 1'-0"

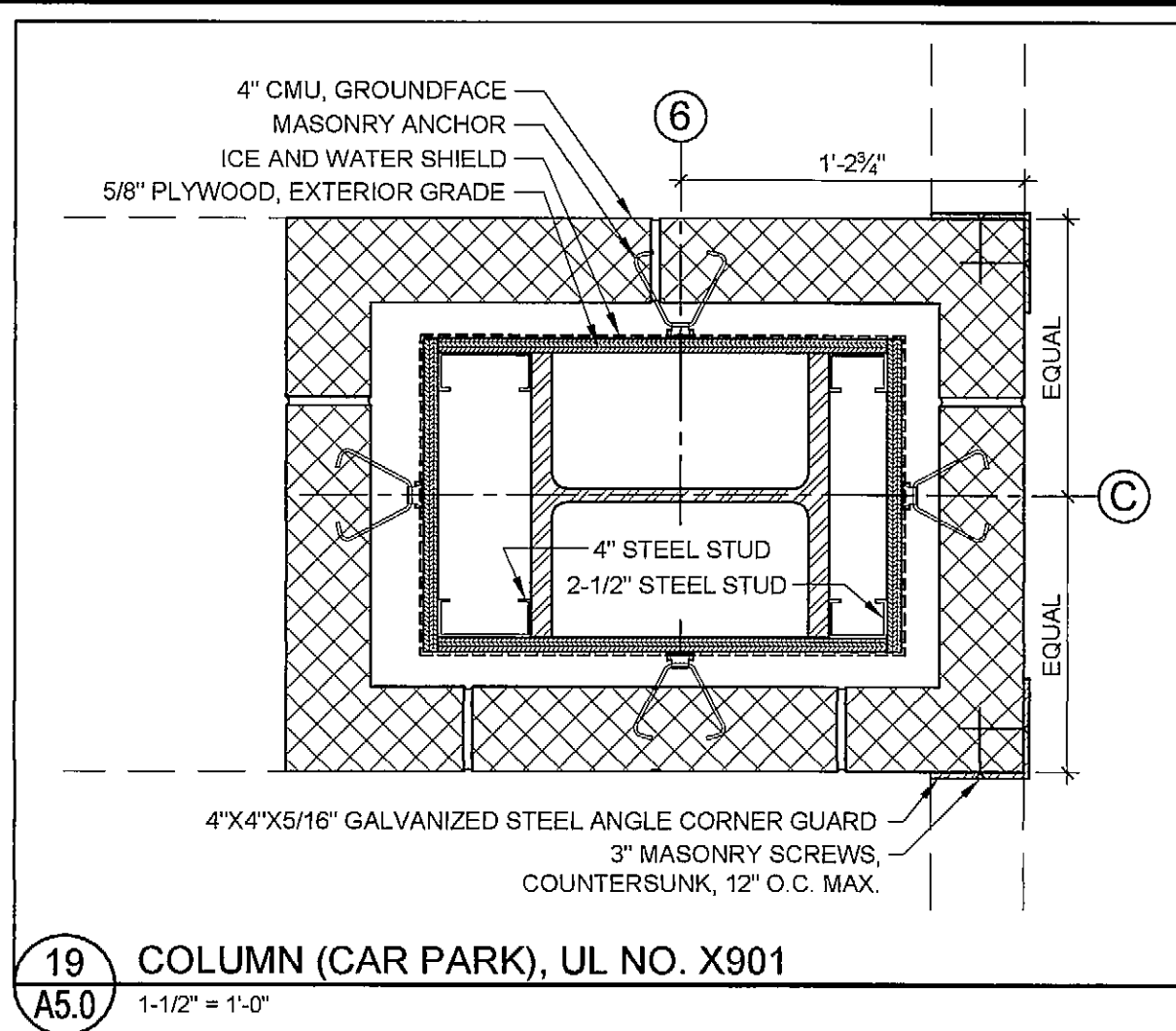

19 COLUMN (CAR PARK), UL NO. X901  
A5.0 1-1/2" = 1'-0"

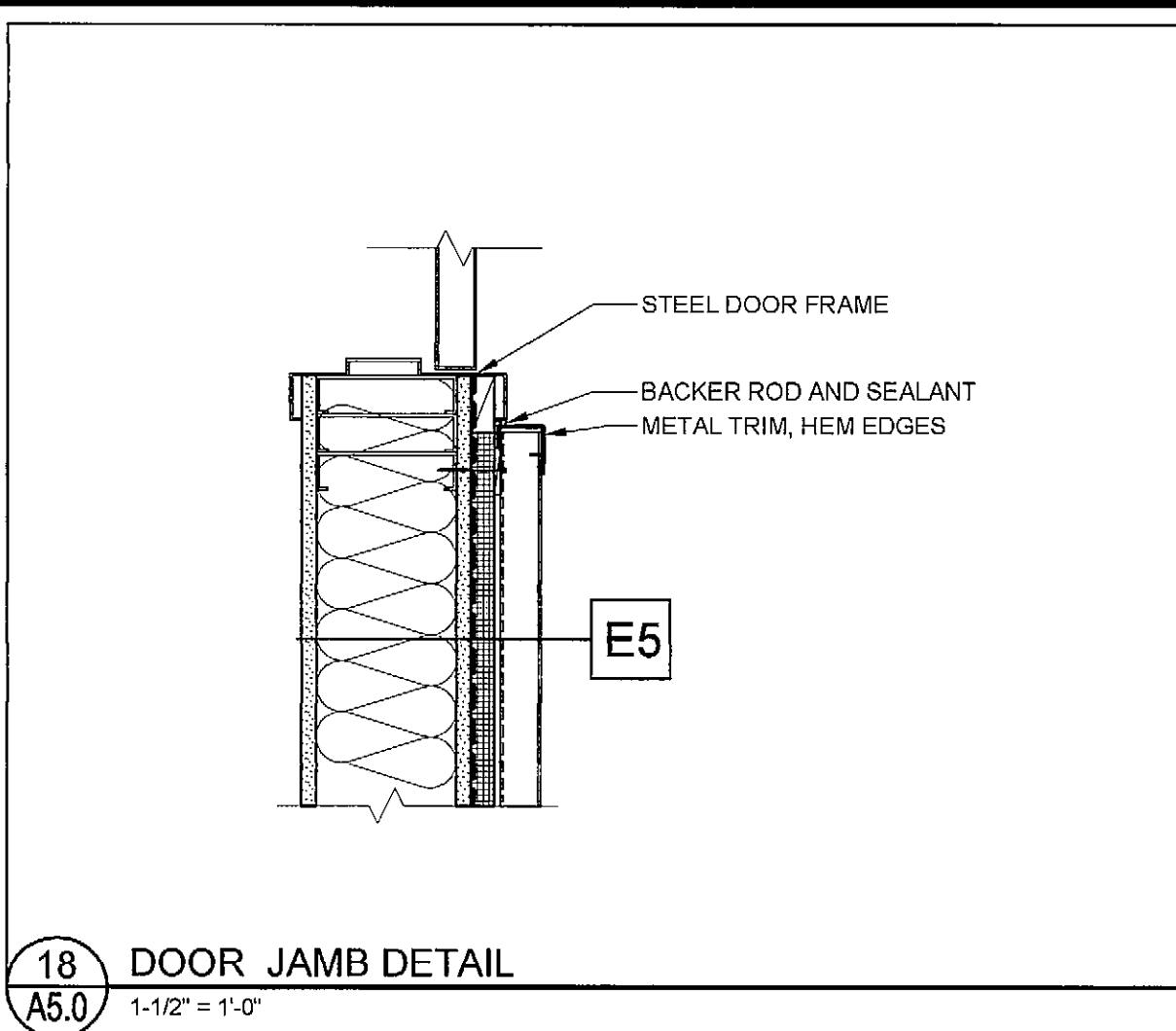

18 DOOR JAMB DETAIL  
A5.0 1-1/2" = 1'-0"

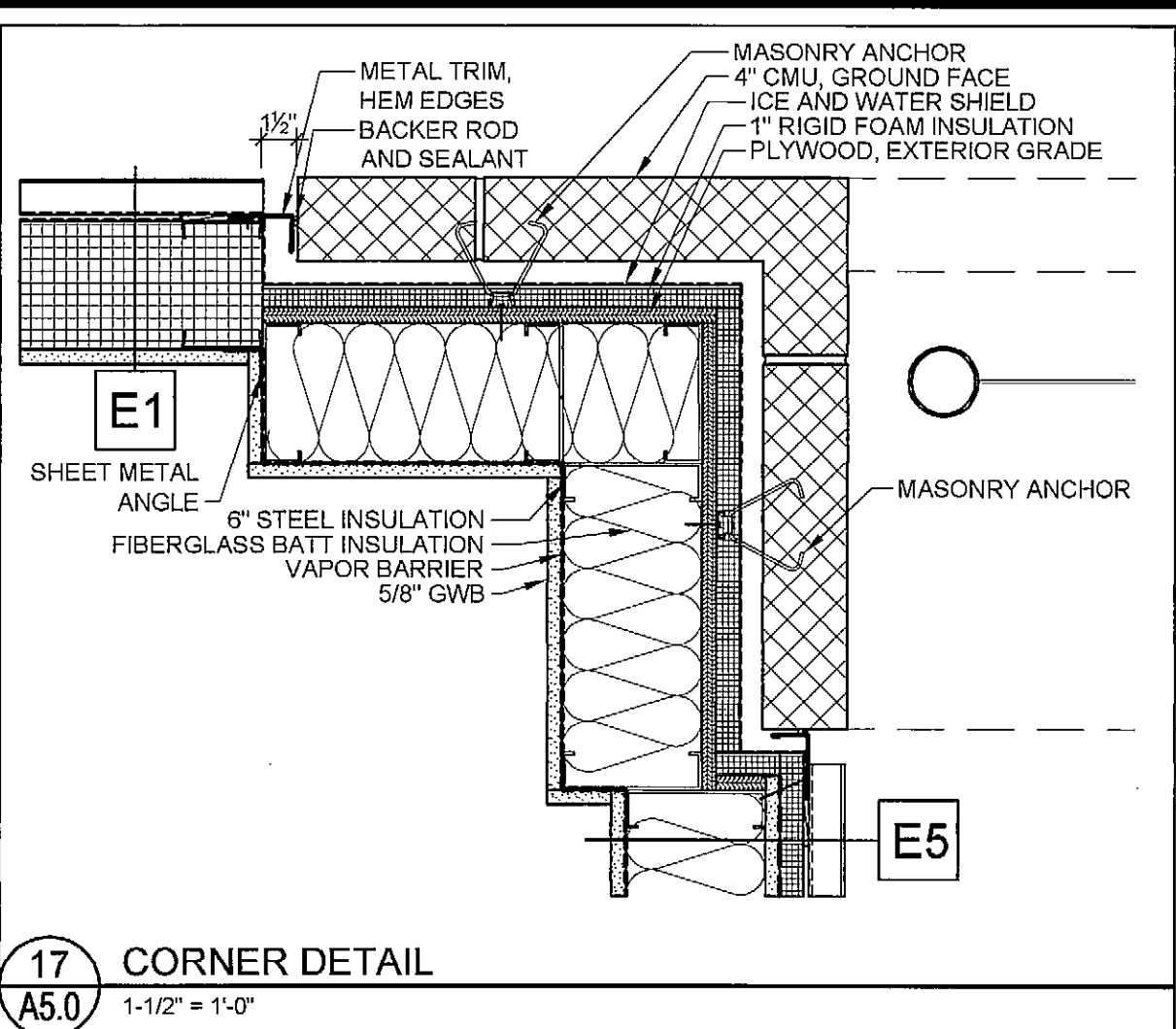

17 CORNER DETAIL  
A5.0 1-1/2" = 1'-0"

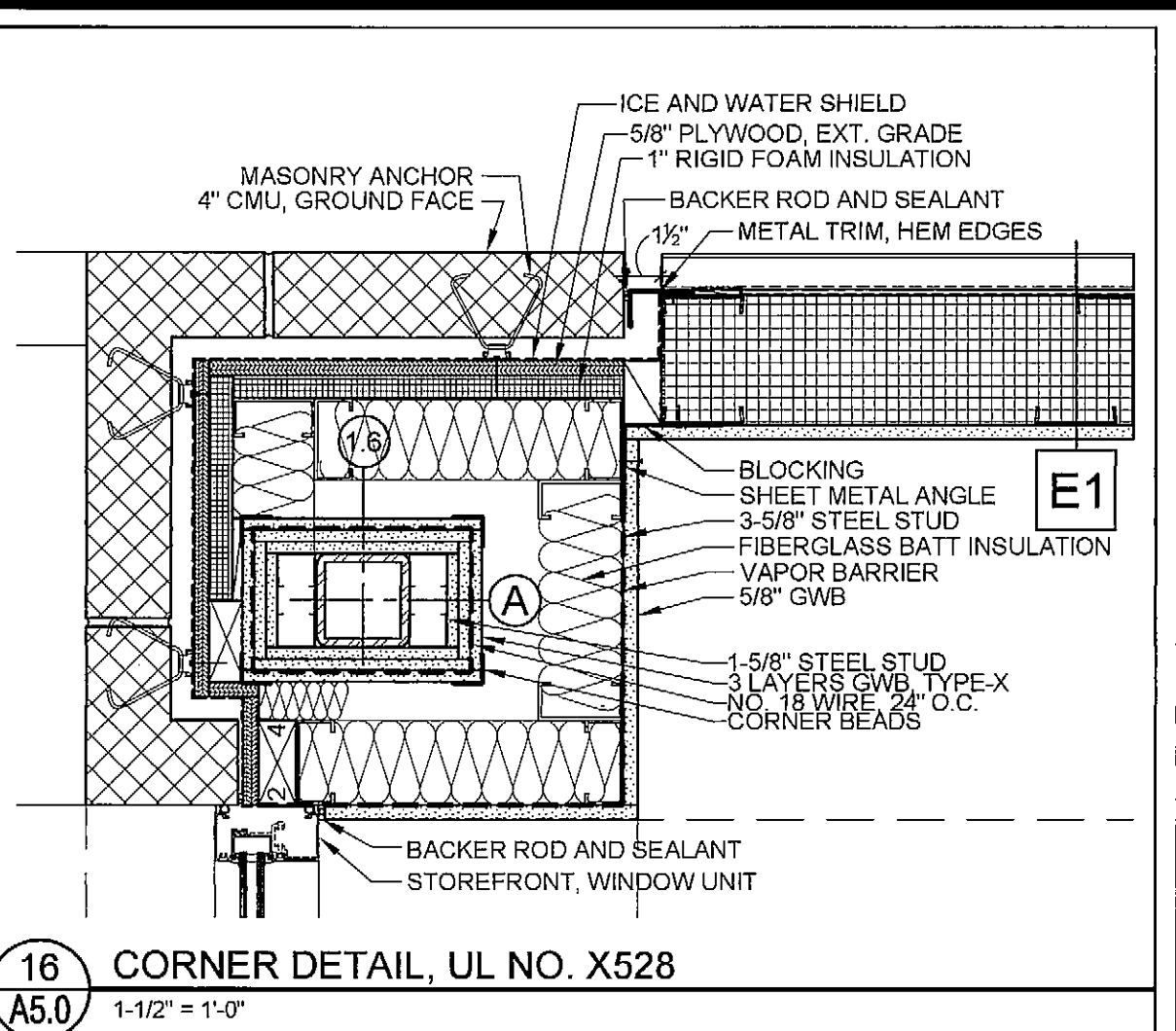

16 CORNER DETAIL, UL NO. X528  
A5.0 1-1/2" = 1'-0"

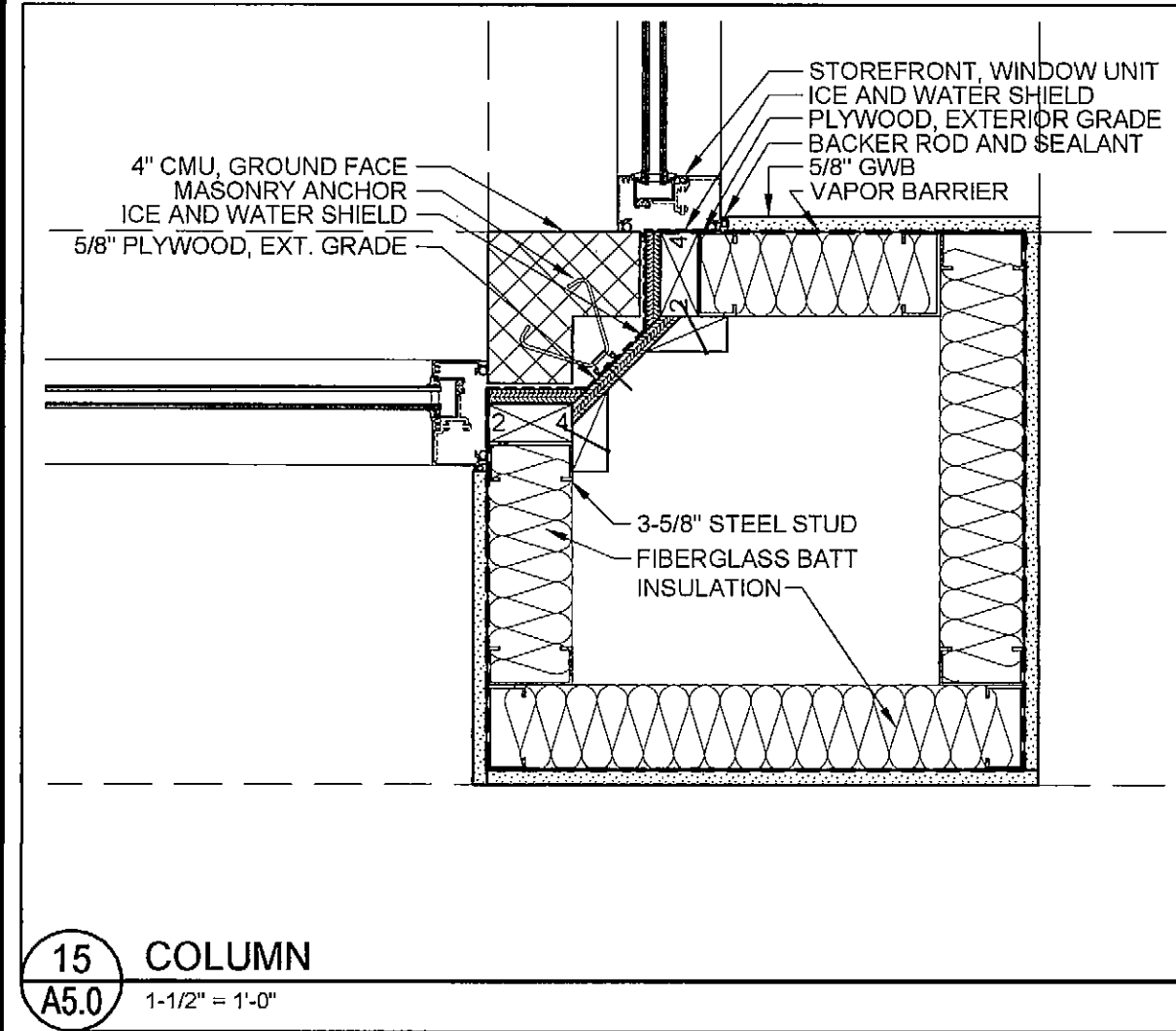

15 COLUMN  
A5.0 1-1/2" = 1'-0"

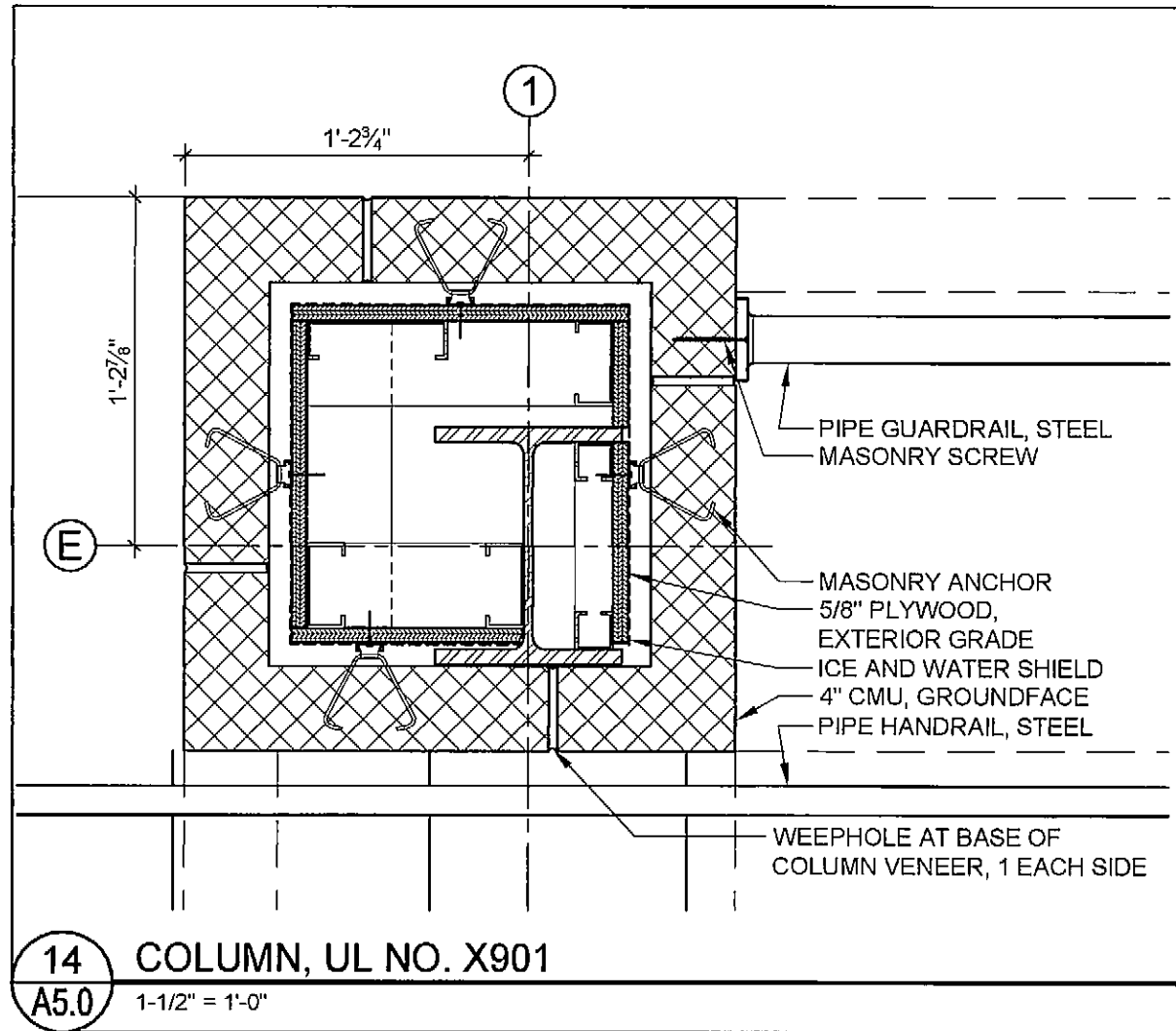

14 COLUMN, UL NO. X901  
A5.0 1-1/2" = 1'-0"

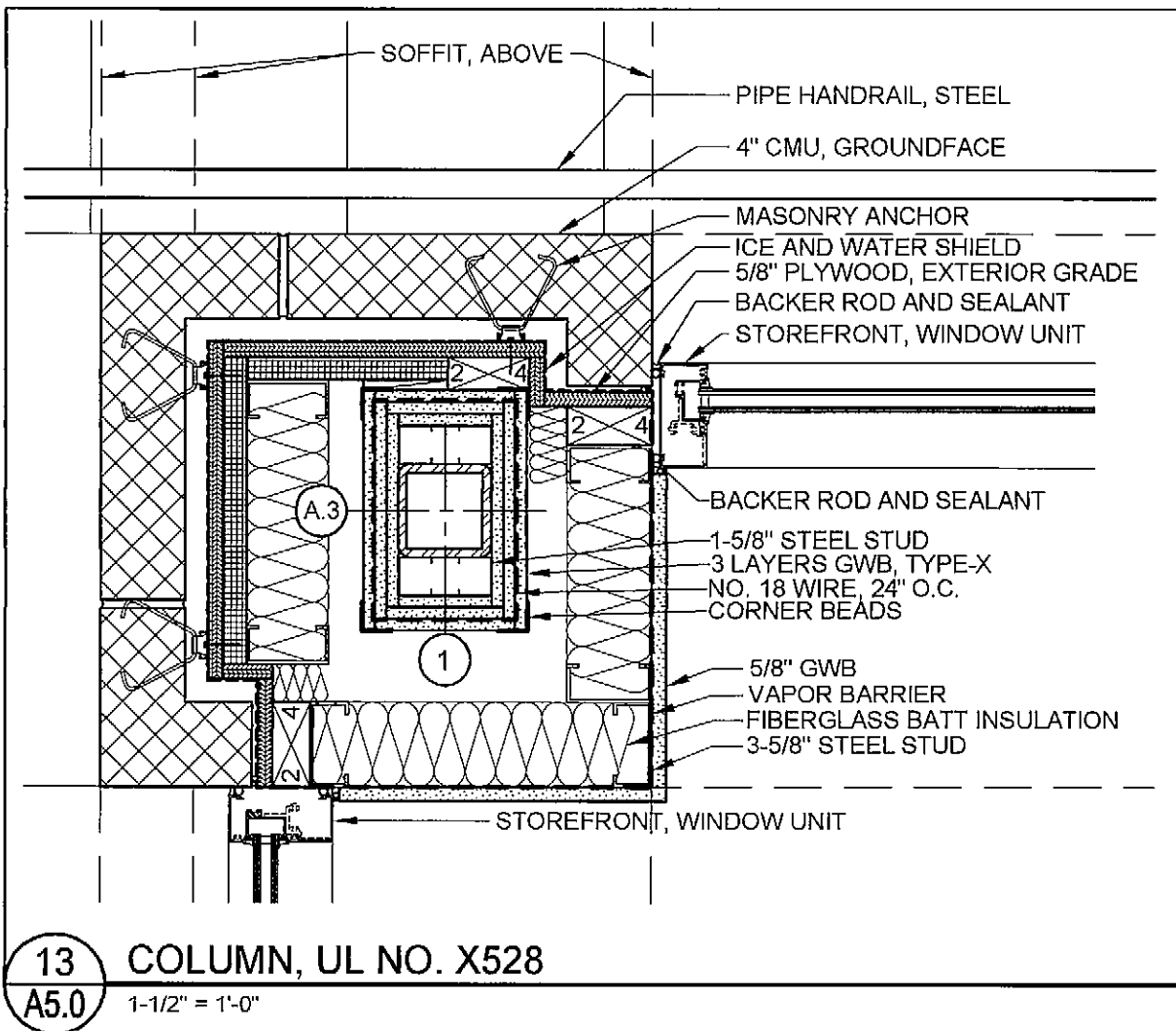

13 COLUMN, UL NO. X528  
A5.0 1-1/2" = 1'-0"

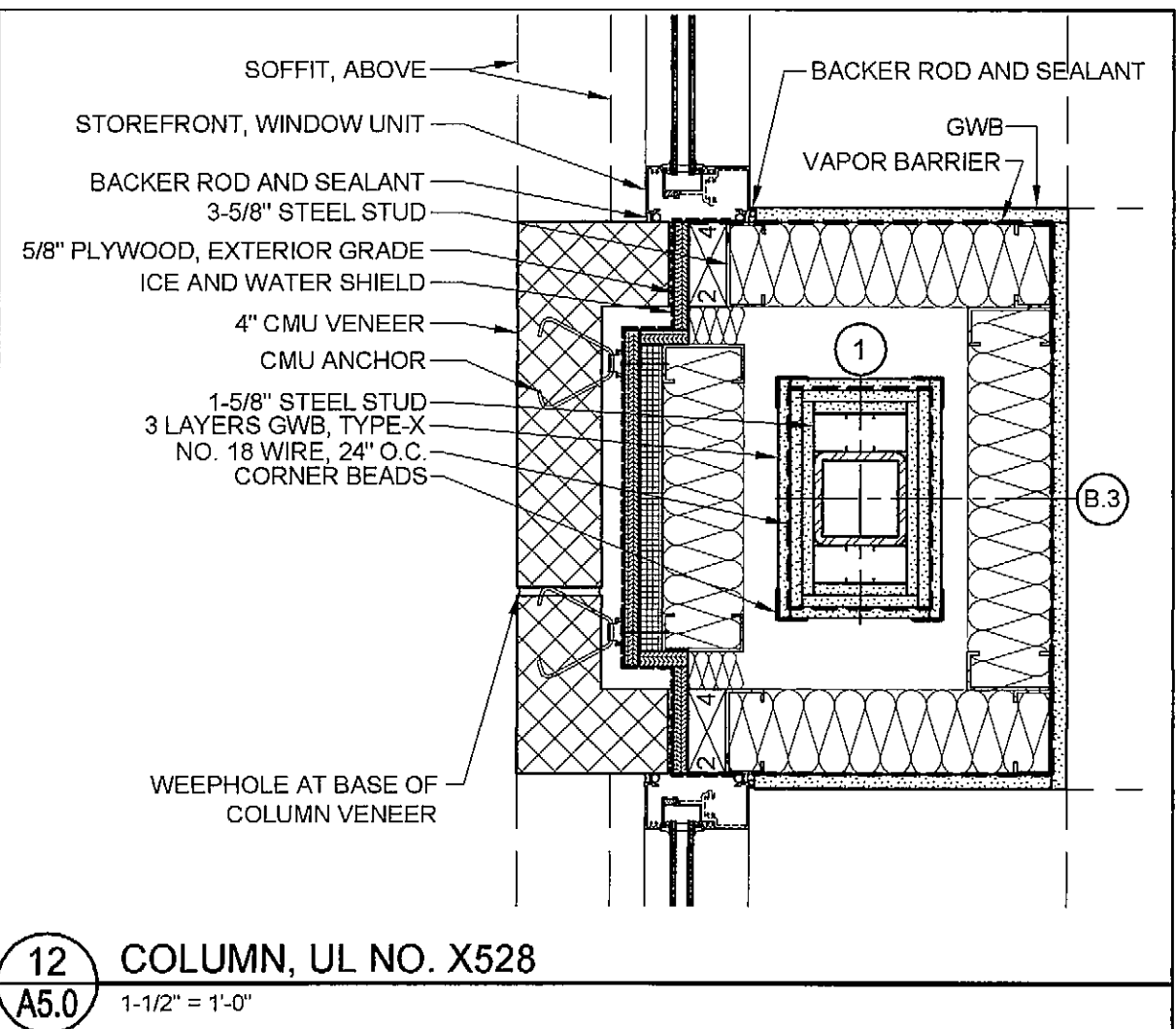

12 COLUMN, UL NO. X528  
A5.0 1-1/2" = 1'-0"

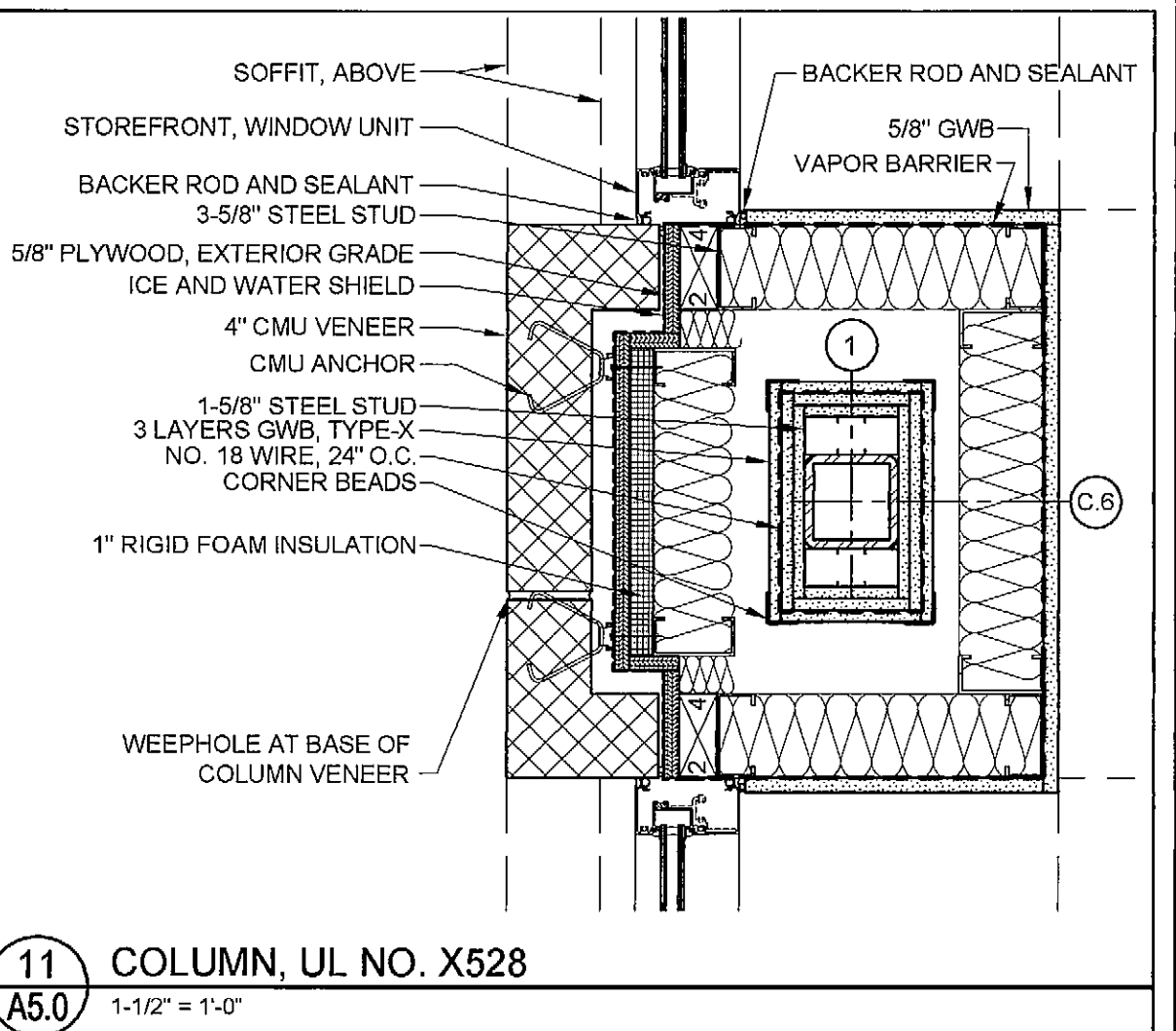

11 COLUMN, UL NO. X528  
A5.0 1-1/2" = 1'-0"

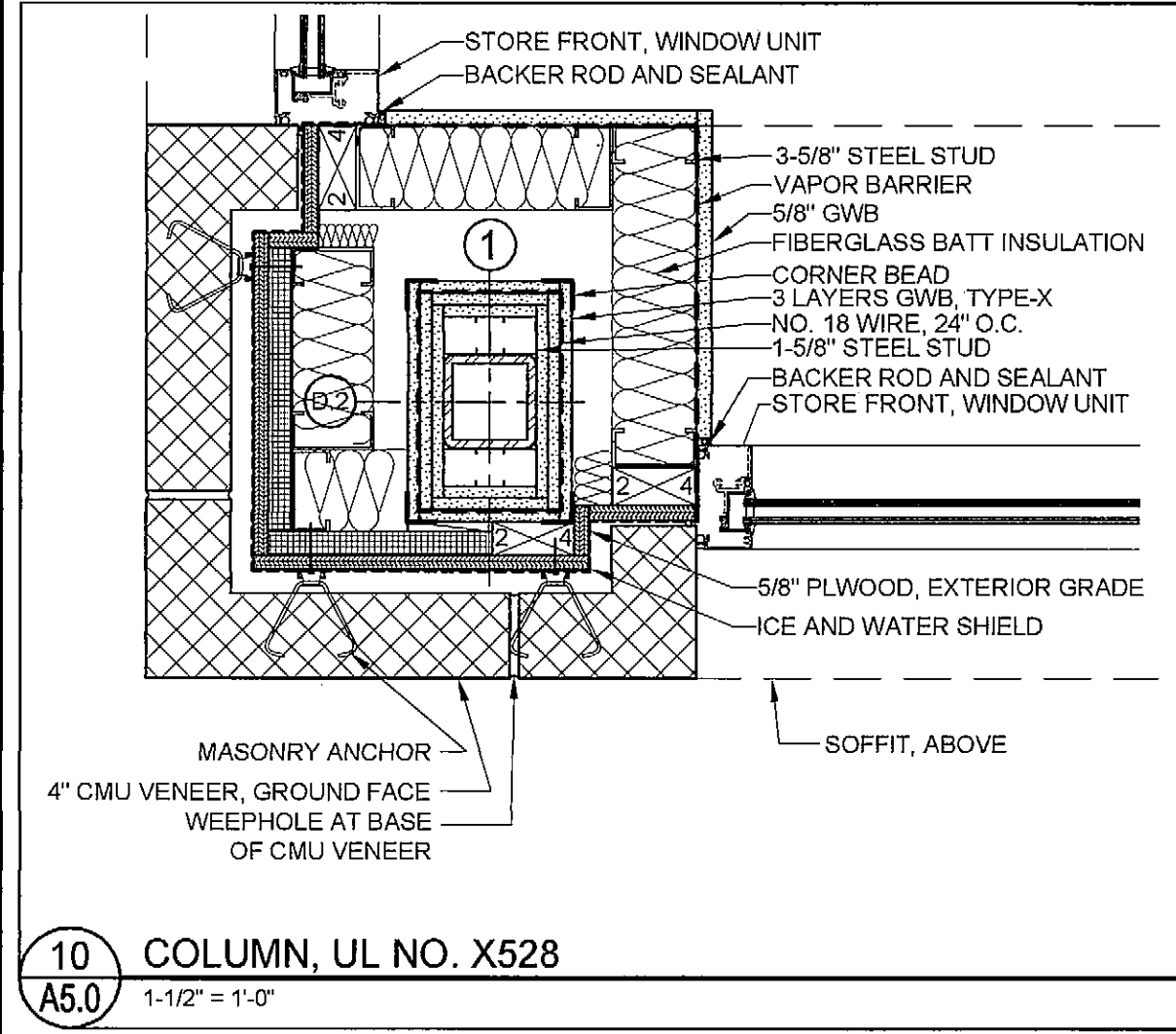

10 COLUMN, UL NO. X528  
A5.0 1-1/2" = 1'-0"

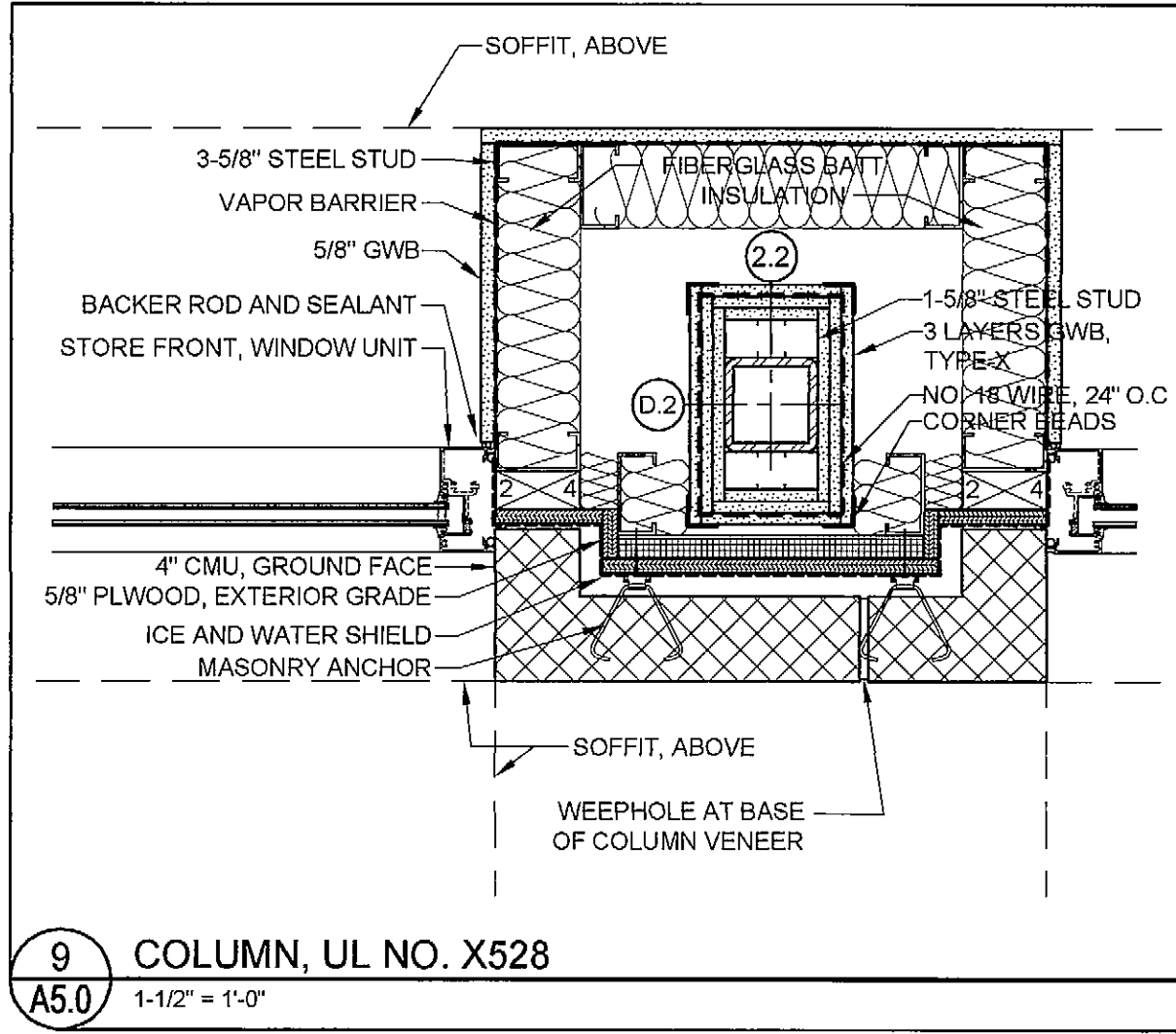

9 COLUMN, UL NO. X528  
A5.0 1-1/2" = 1'-0"

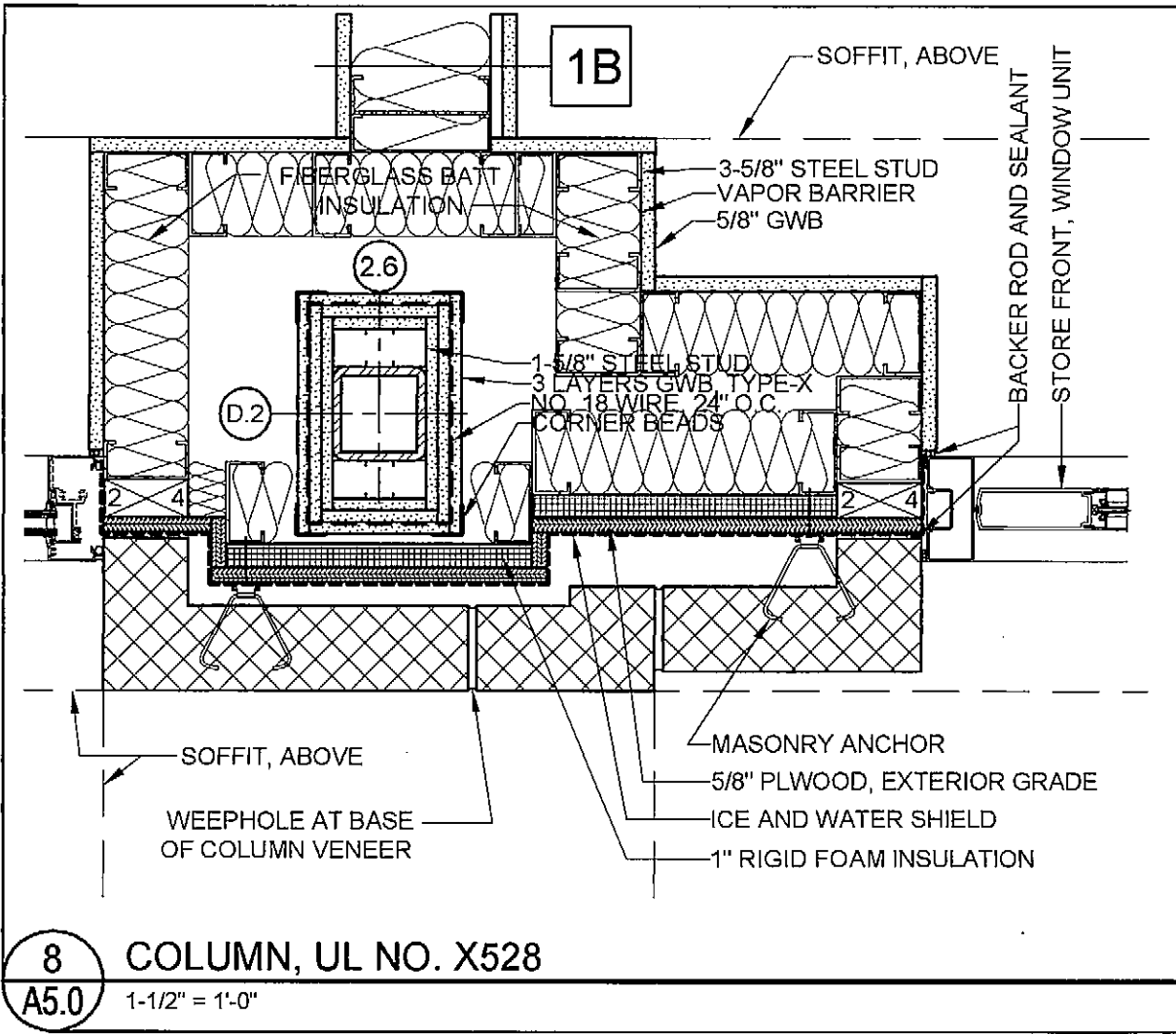

8 COLUMN, UL NO. X528  
A5.0 1-1/2" = 1'-0"

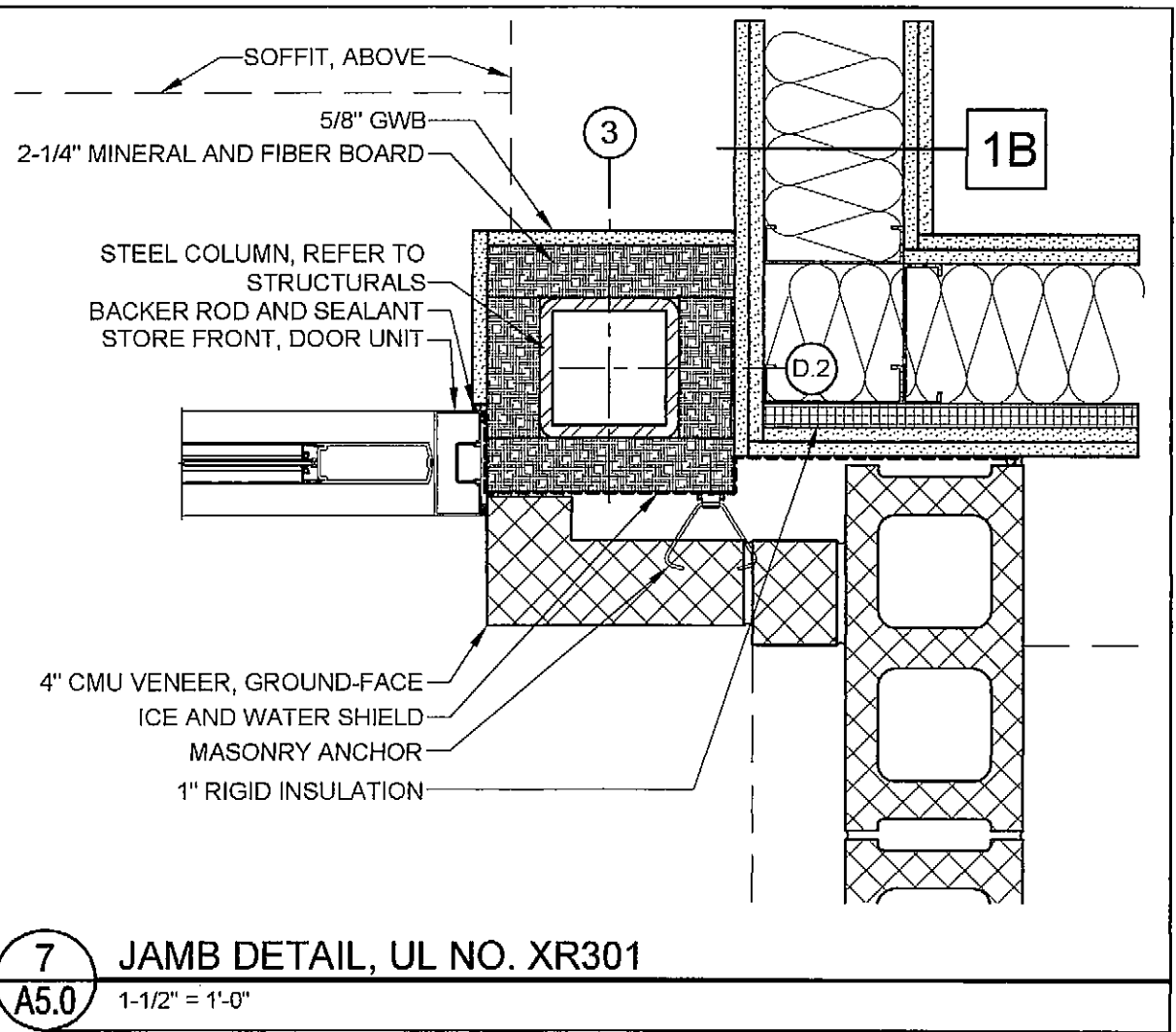

7 JAMB DETAIL, UL NO. XR301  
A5.0 1-1/2" = 1'-0"

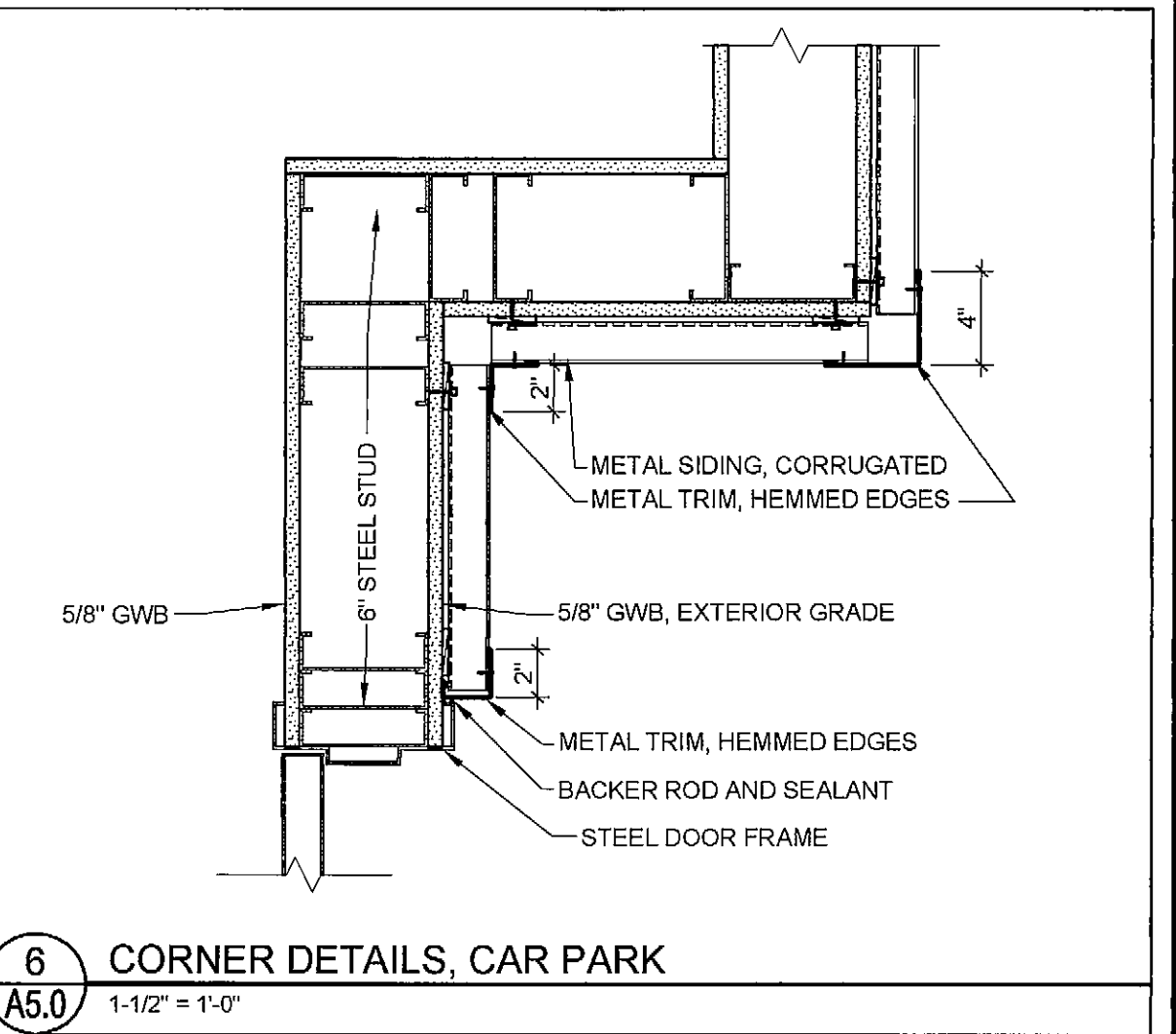

6 CORNER DETAILS, CAR PARK  
A5.0 1-1/2" = 1'-0"

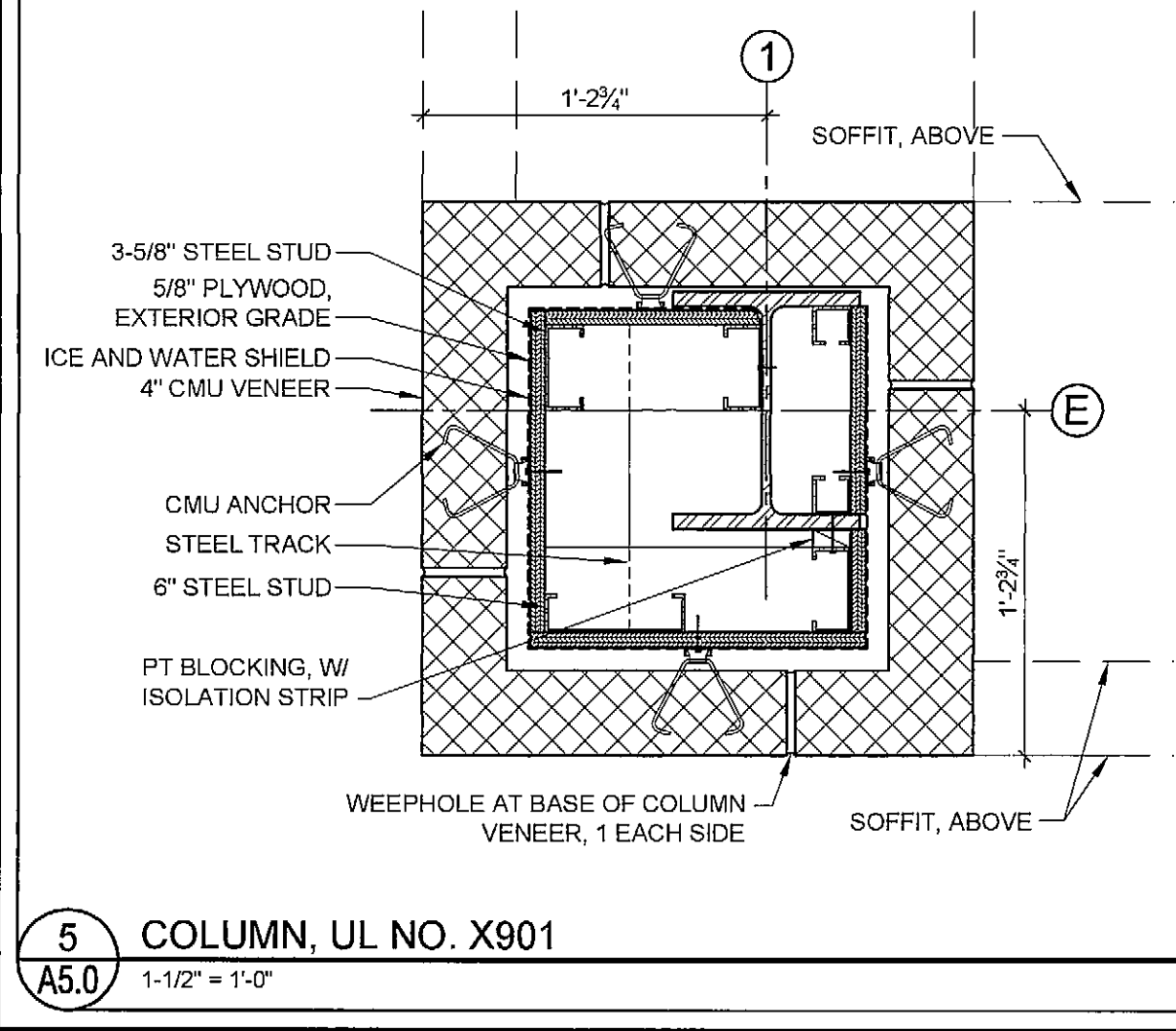

5 COLUMN, UL NO. X901  
A5.0 1-1/2" = 1'-0"

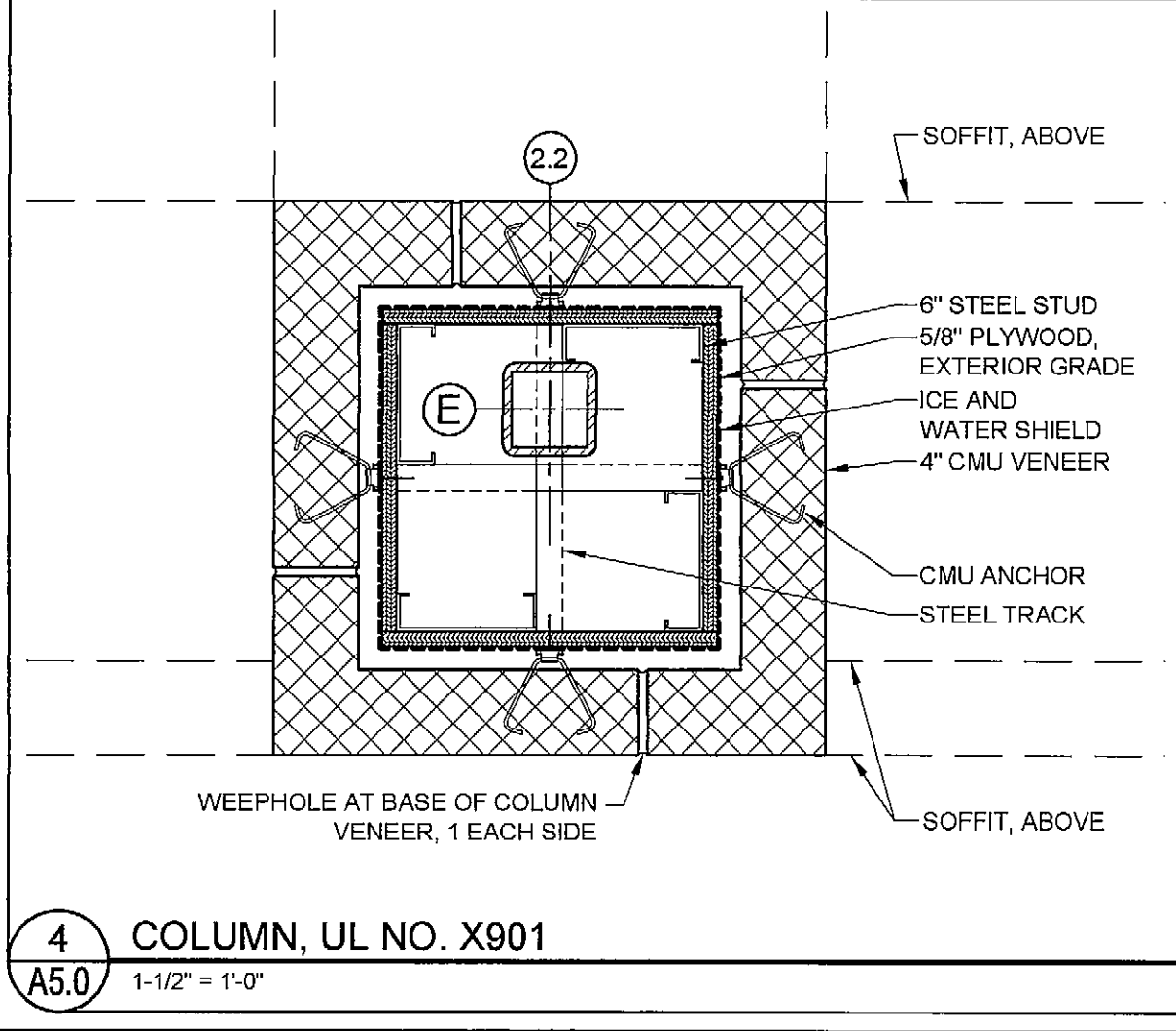

4 COLUMN, UL NO. X901  
A5.0 1-1/2" = 1'-0"

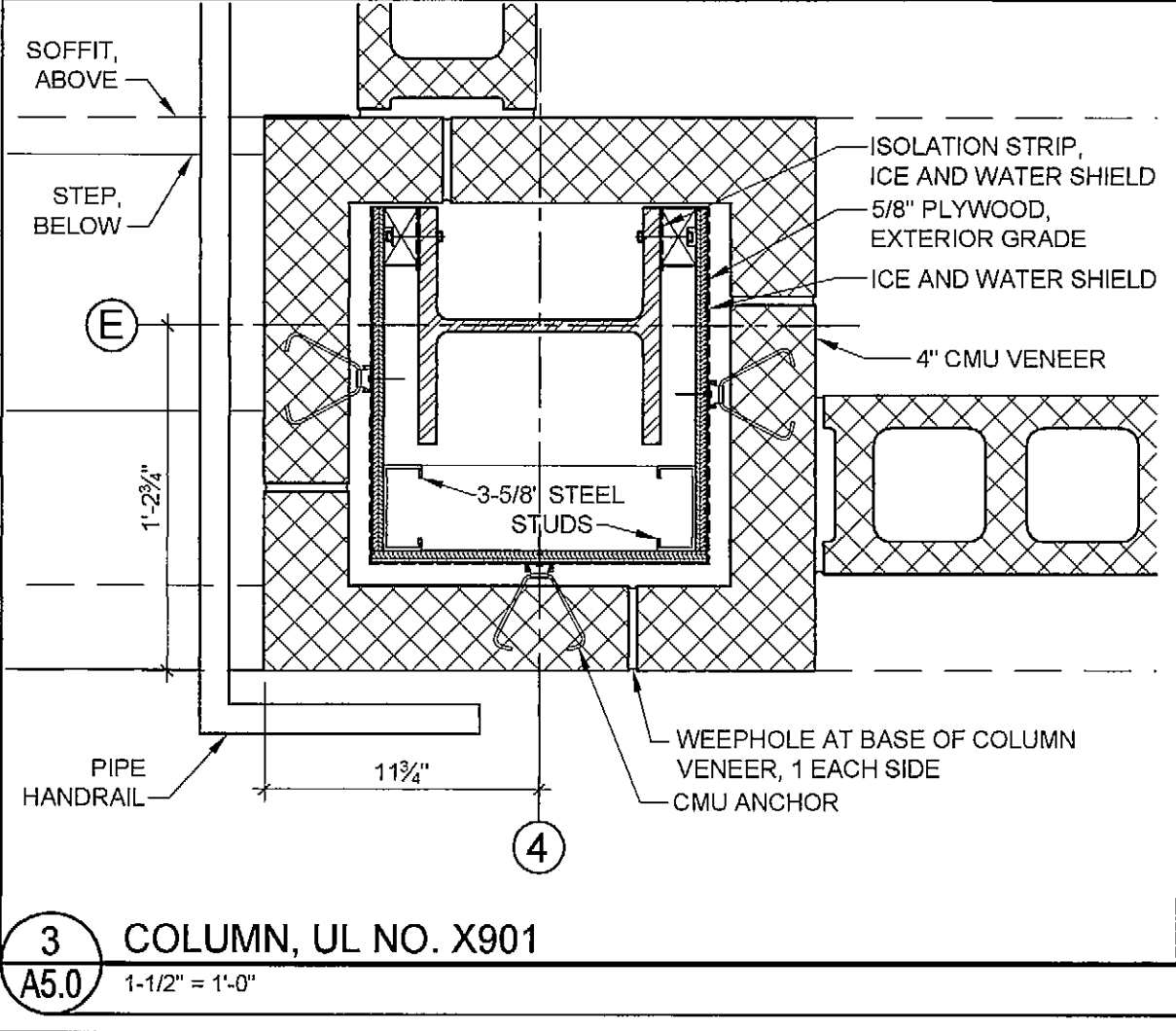

3 COLUMN, UL NO. X901  
A5.0 1-1/2" = 1'-0"

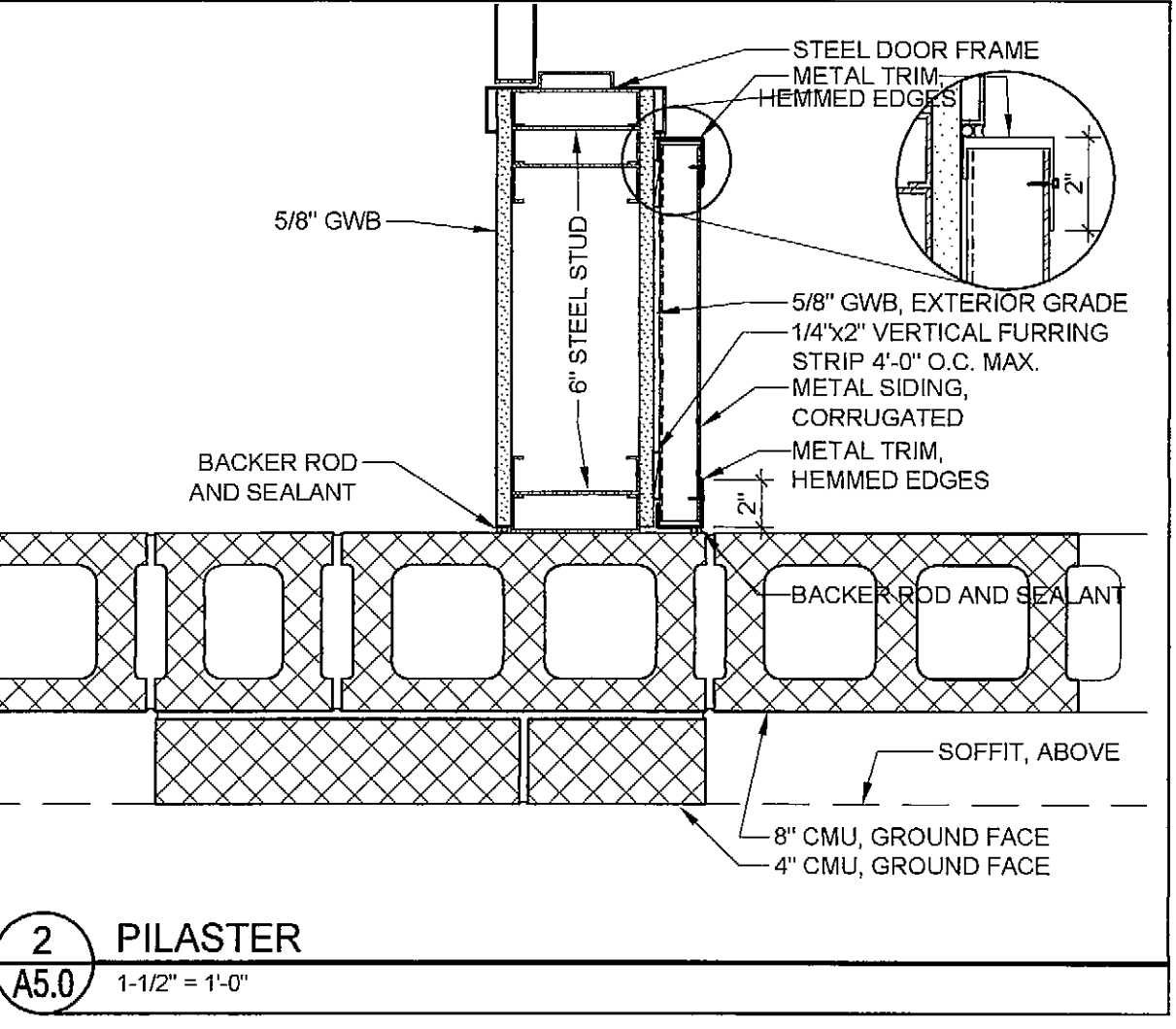

2 PILASTER  
A5.0 1-1/2" = 1'-0"

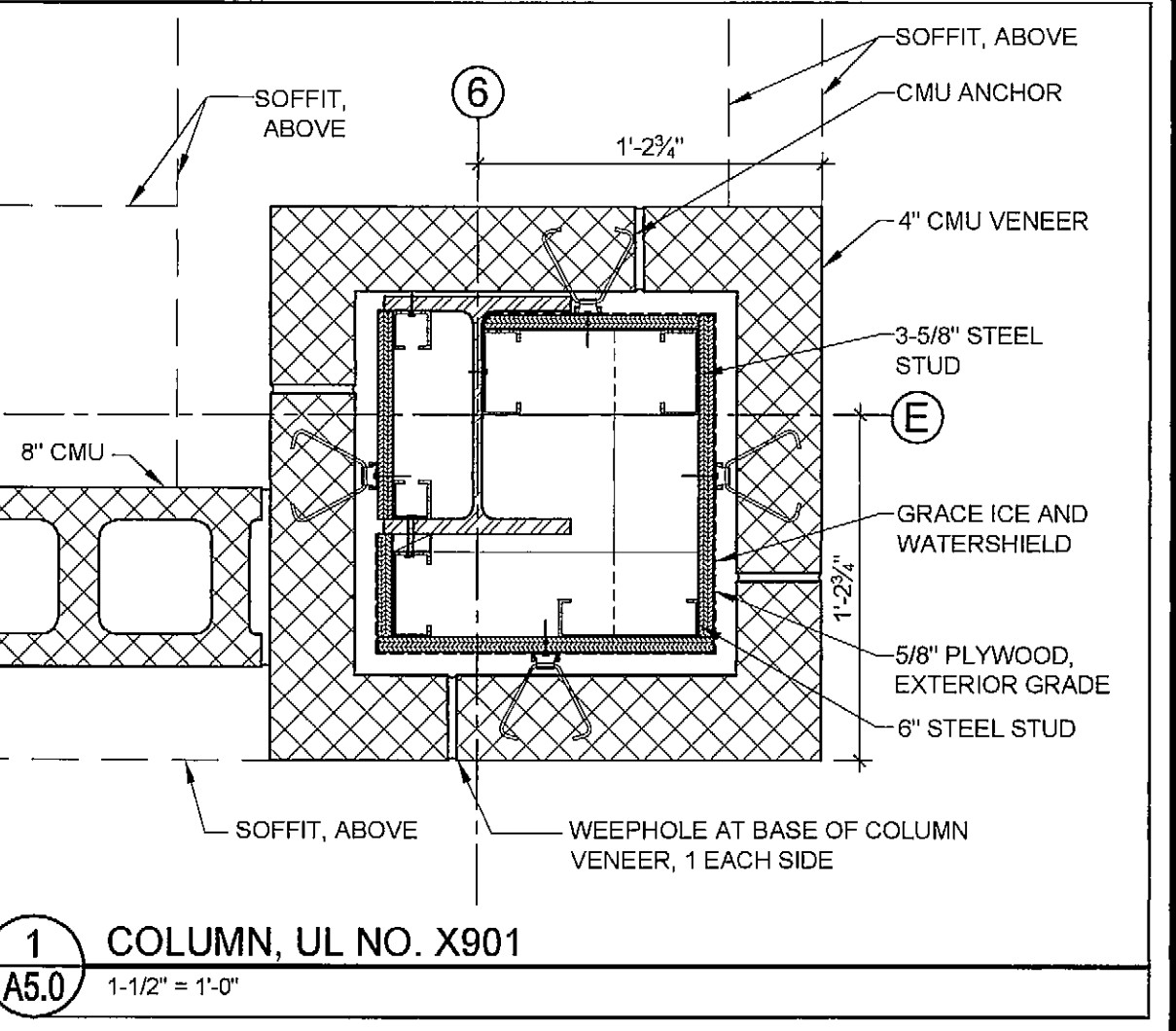

1 COLUMN, UL NO. X901  
A5.0 1-1/2" = 1'-0"

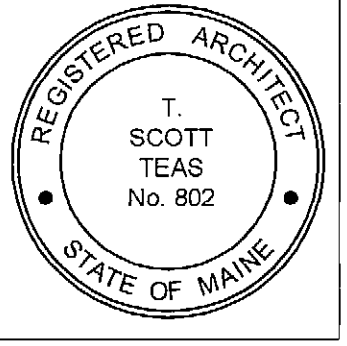

© 2005 TFH ARCHITECTS

CHESTNUT STREET LOFTS  
URBAN REVITALIZATION PROJECT  
BY CHESTNUT STREET LLC.  
PORTLAND, MAINE



CONSULTANTS:  
Civil: Land Use Consultants  
555 Riverside Street  
Portland, ME 04103  
207-878-3313  
Structural: Structural Design Consulting  
22 Oakmont Drive  
Old Orchard Beach, ME 04054  
207-834-8008  
MECHANICAL: Wilbur Engineering  
10 Danforth Street  
Portland, ME 04101  
207-874-7489  
ELECTRICAL: Daniels Engineering  
7 Bennett Road  
Fryeburg, ME 04032  
207-865-8475

REVISIONS:

100% CONSTRUCTION DOCUMENTS  
2/22/08

DATE:  
PROJECT No. 0422  
DRAWN BY: CSC  
CHECKED BY: TST  
SCALE: AS NOTED

SHEET TITLE:  
PLAN DETAILS

A5.0