

ELEVATION 1 (expanded to show true dimensions)

1/4"=1'-0"

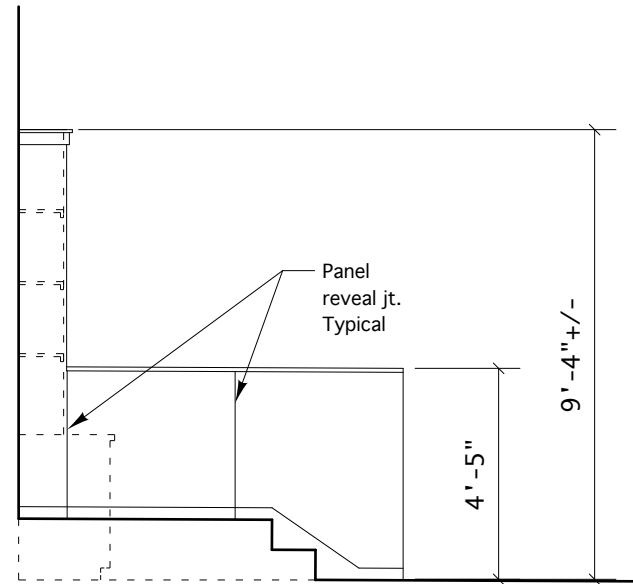

ELEVATION 2

1/4"=1'-0"

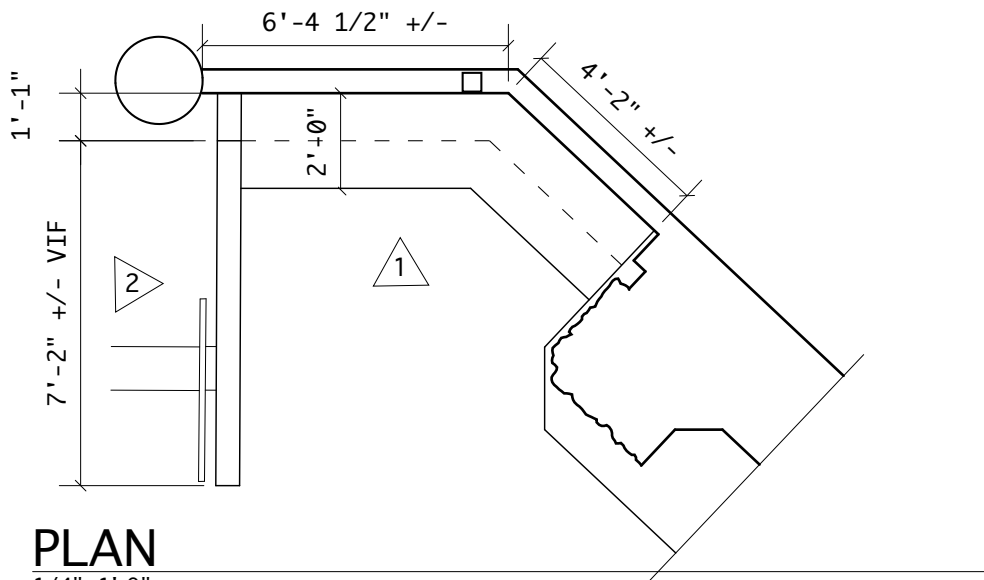

PLAN

1/4"=1'-0"

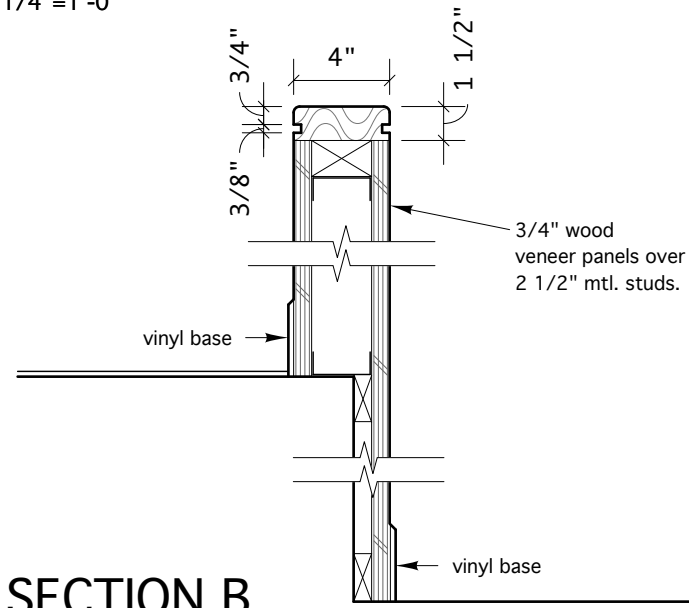

SECTION B

1 1/2"=1'-0"

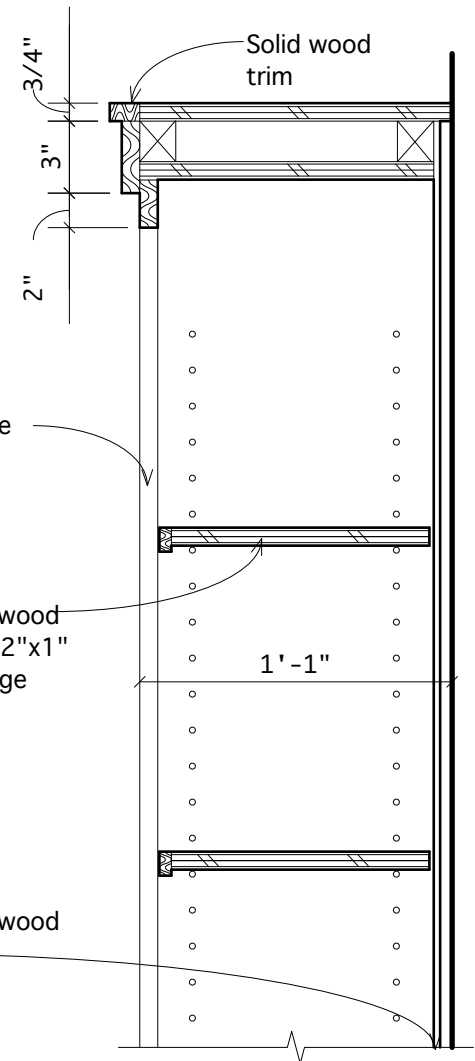
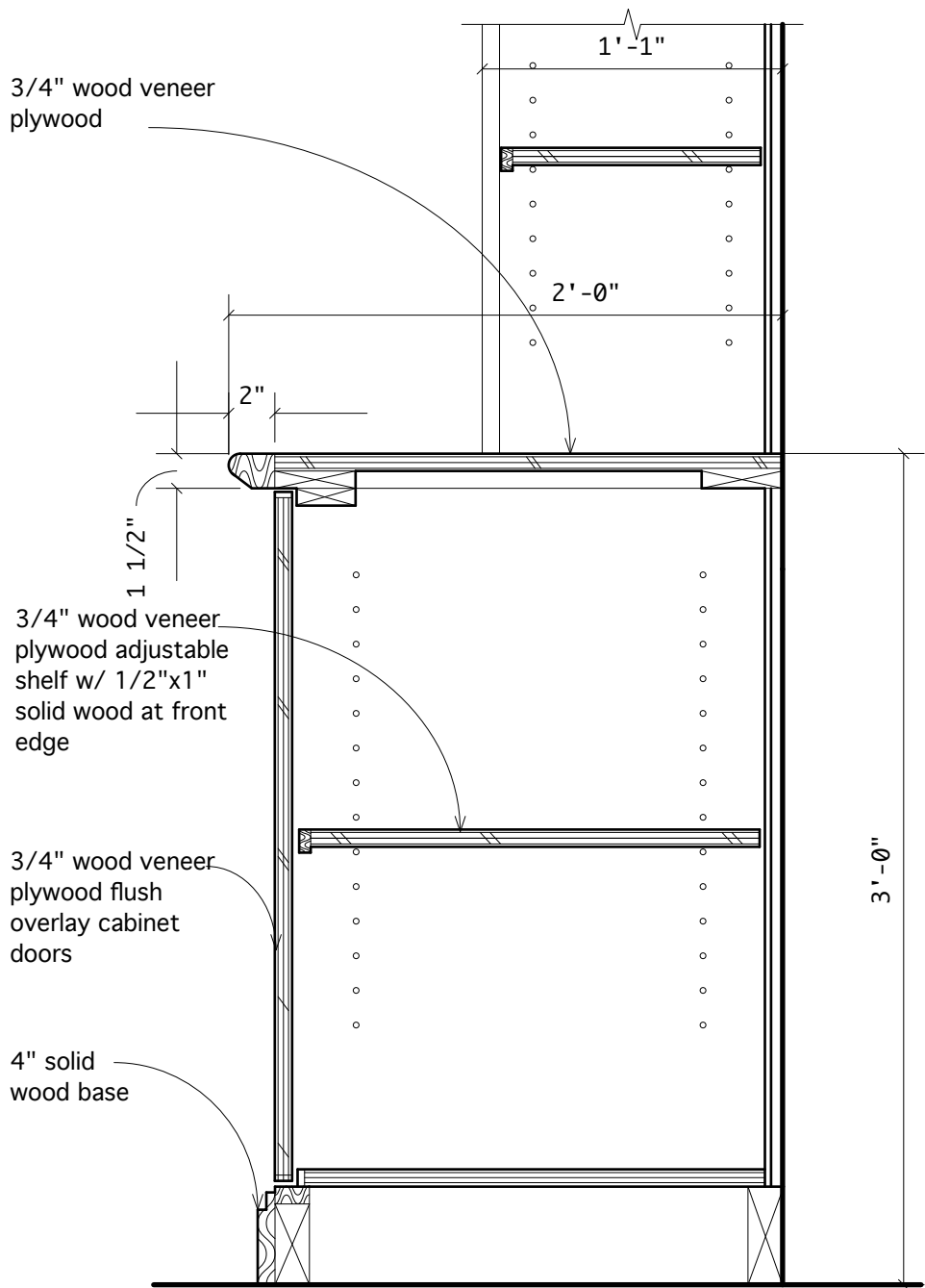

SECTION A
1 1/2"=1'-0"