

PLAN OF CAFE VESTIBULE AT SECOND FLOOR LEVEL.

3/32" = 1'-0"

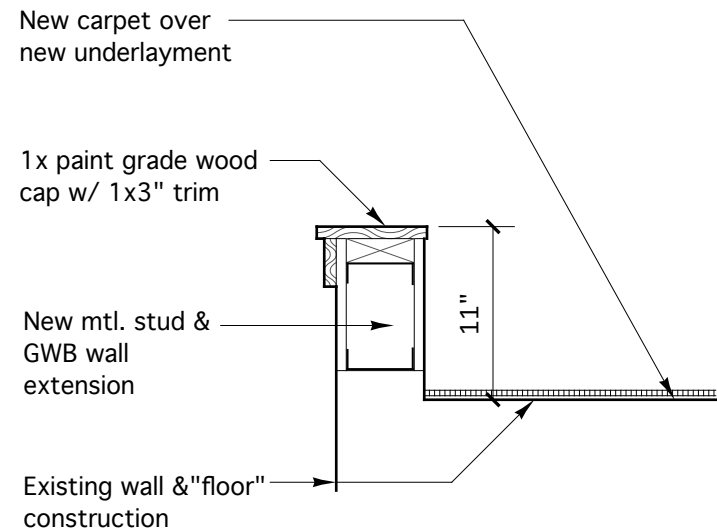

DETAIL OF WALL EXTENSION AT CAFE VESTIBULE

1" = 1'-0"