

PLAN AT RAMP RAILS

1/4" = 1'-0"

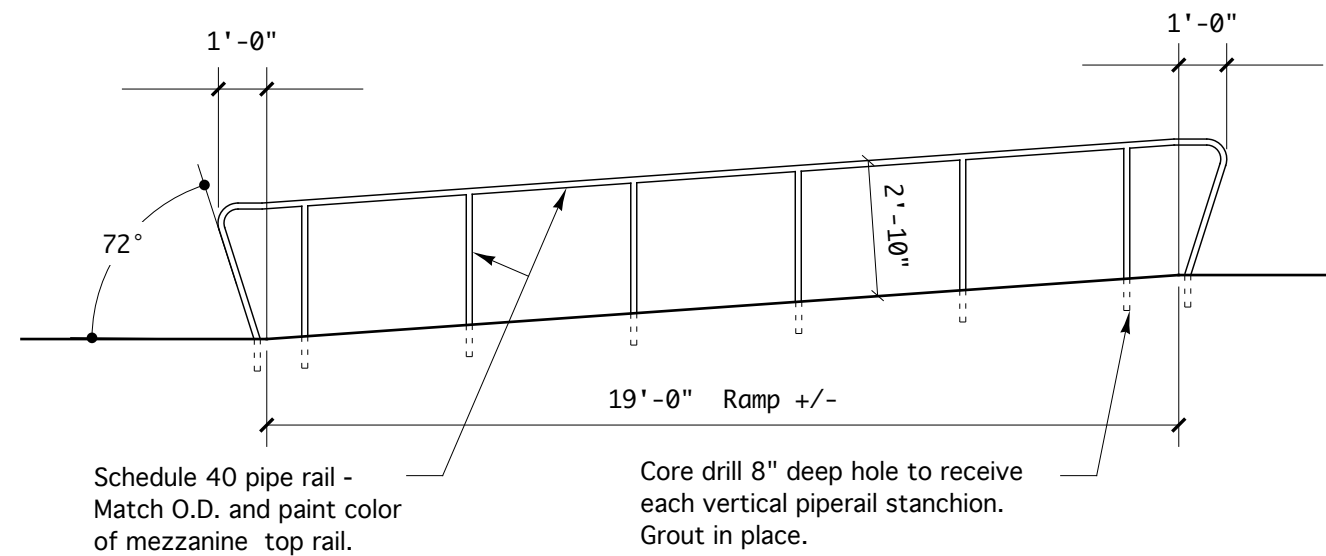
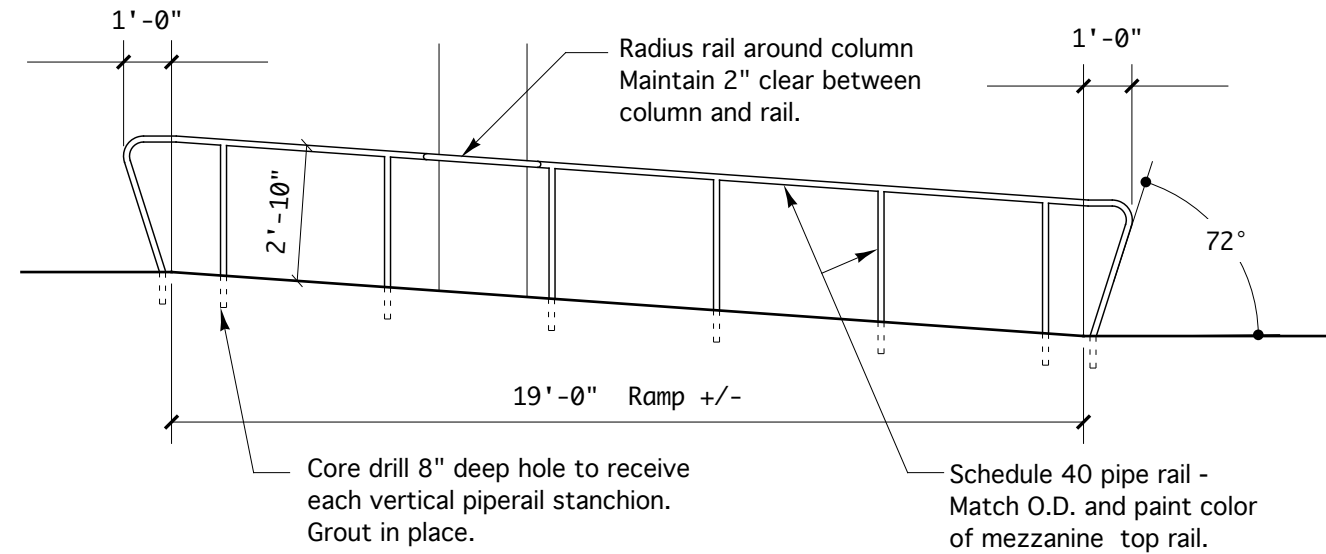

PLAN AT RAMP RAILS

1/4" = 1'-0"

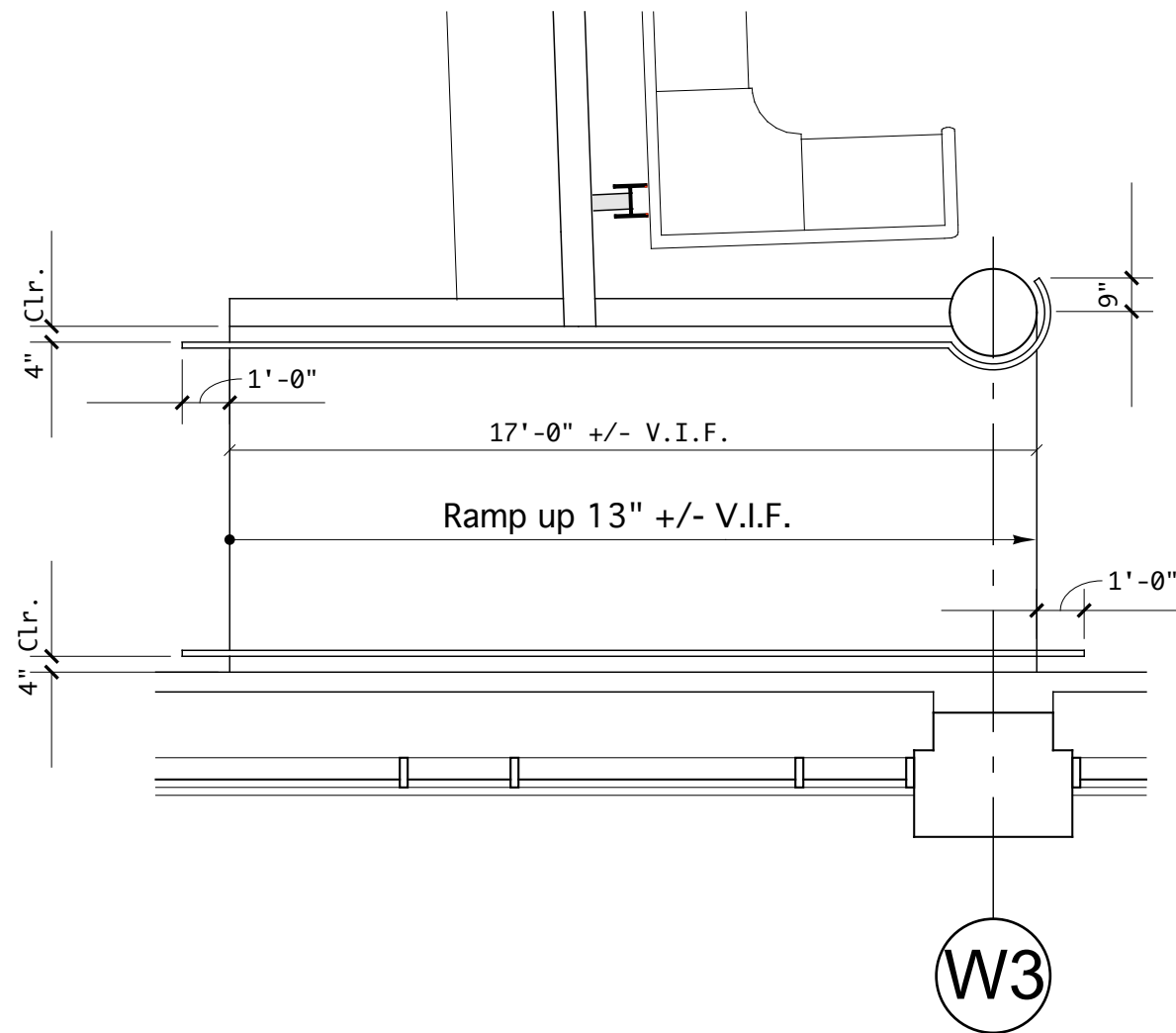

PLAN AT RAMP RAILS

1/4" = 1'-0"

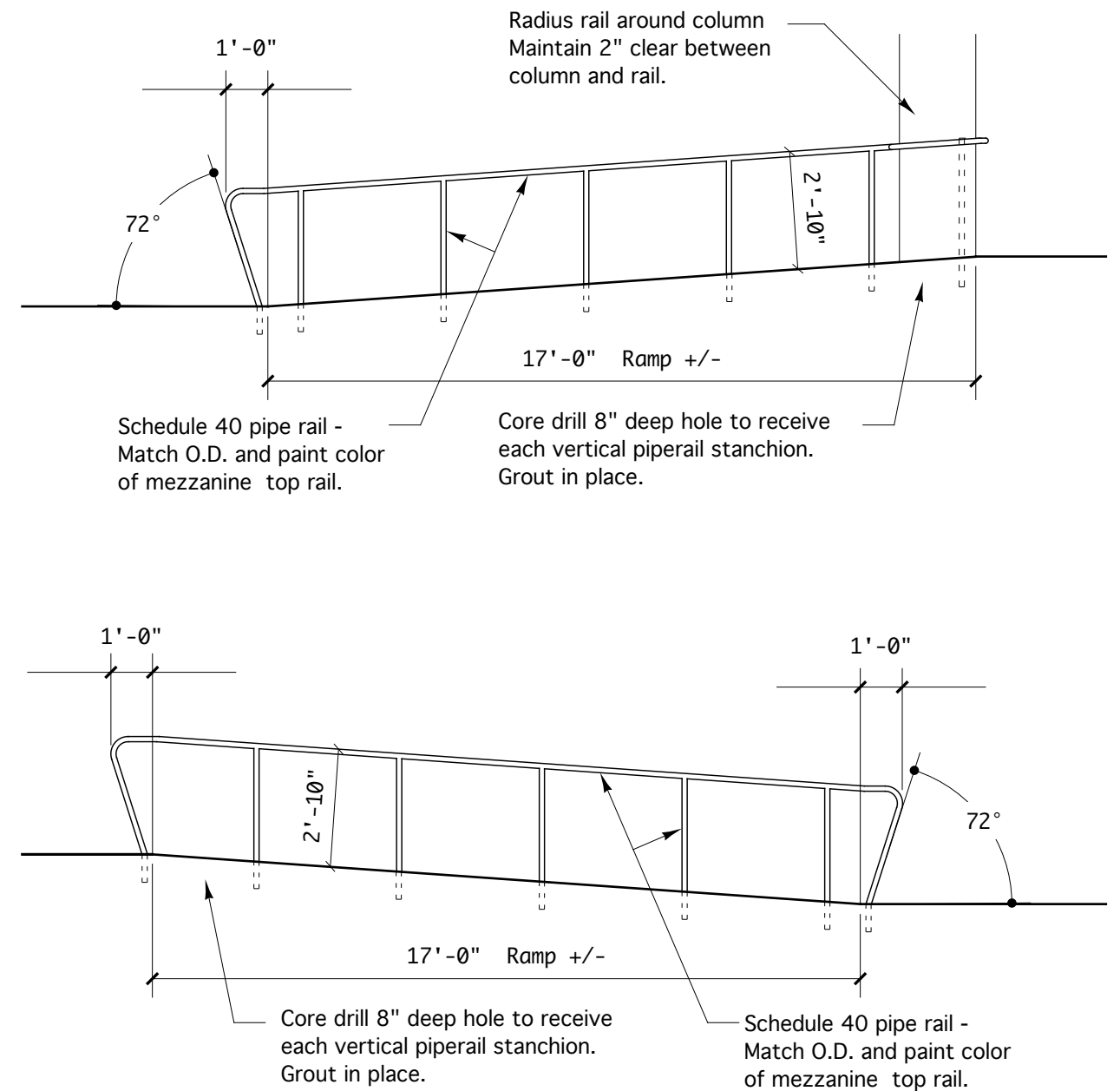

RAMP RAILS ELEVATIONS

1/4" = 1'-0"