

1 TYPICAL WALL HANDRAIL SECTION 3/4" = 1'-0"

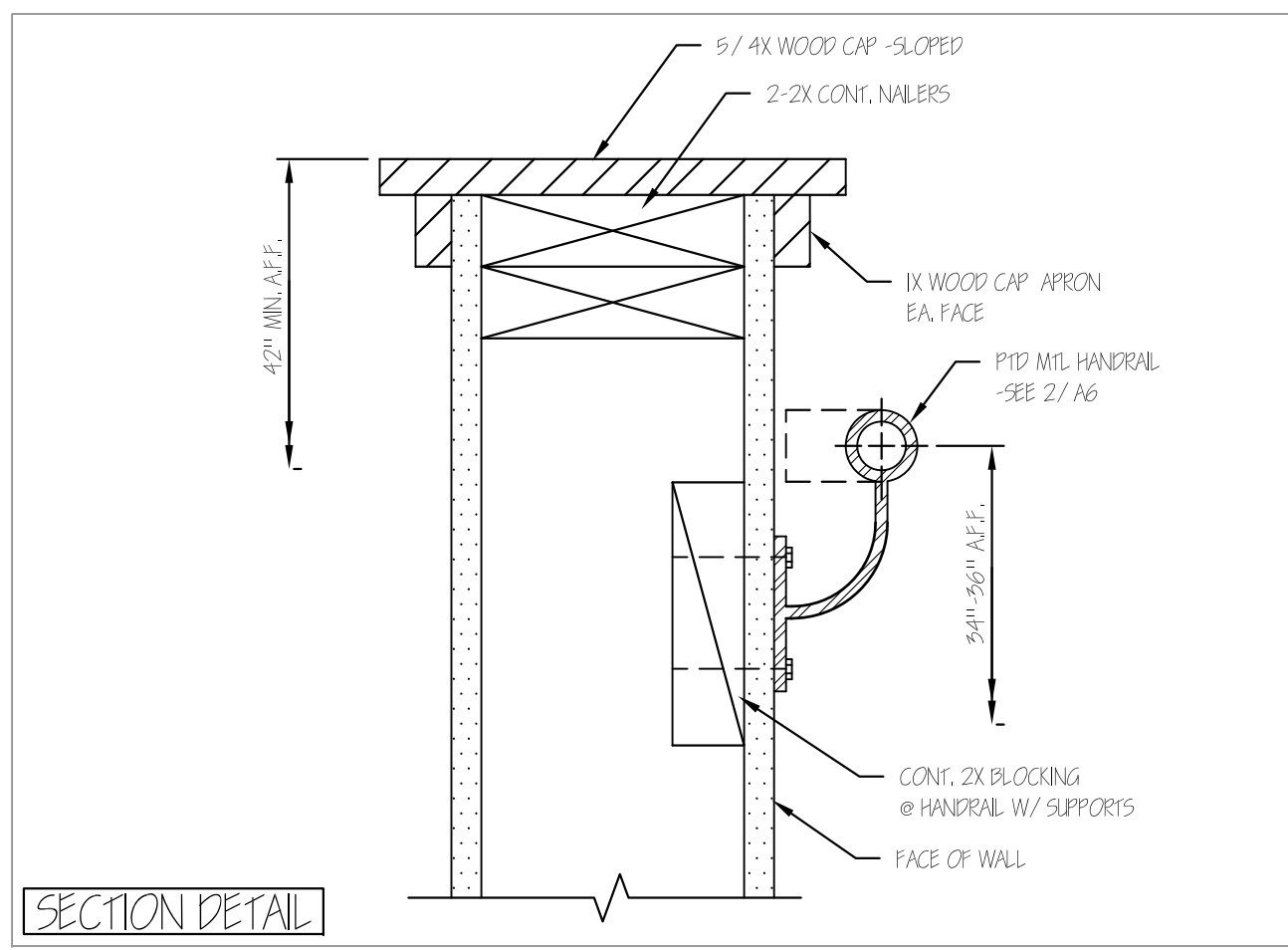

2 STAIR GUARDRAIL 3/4" = 1'-0"

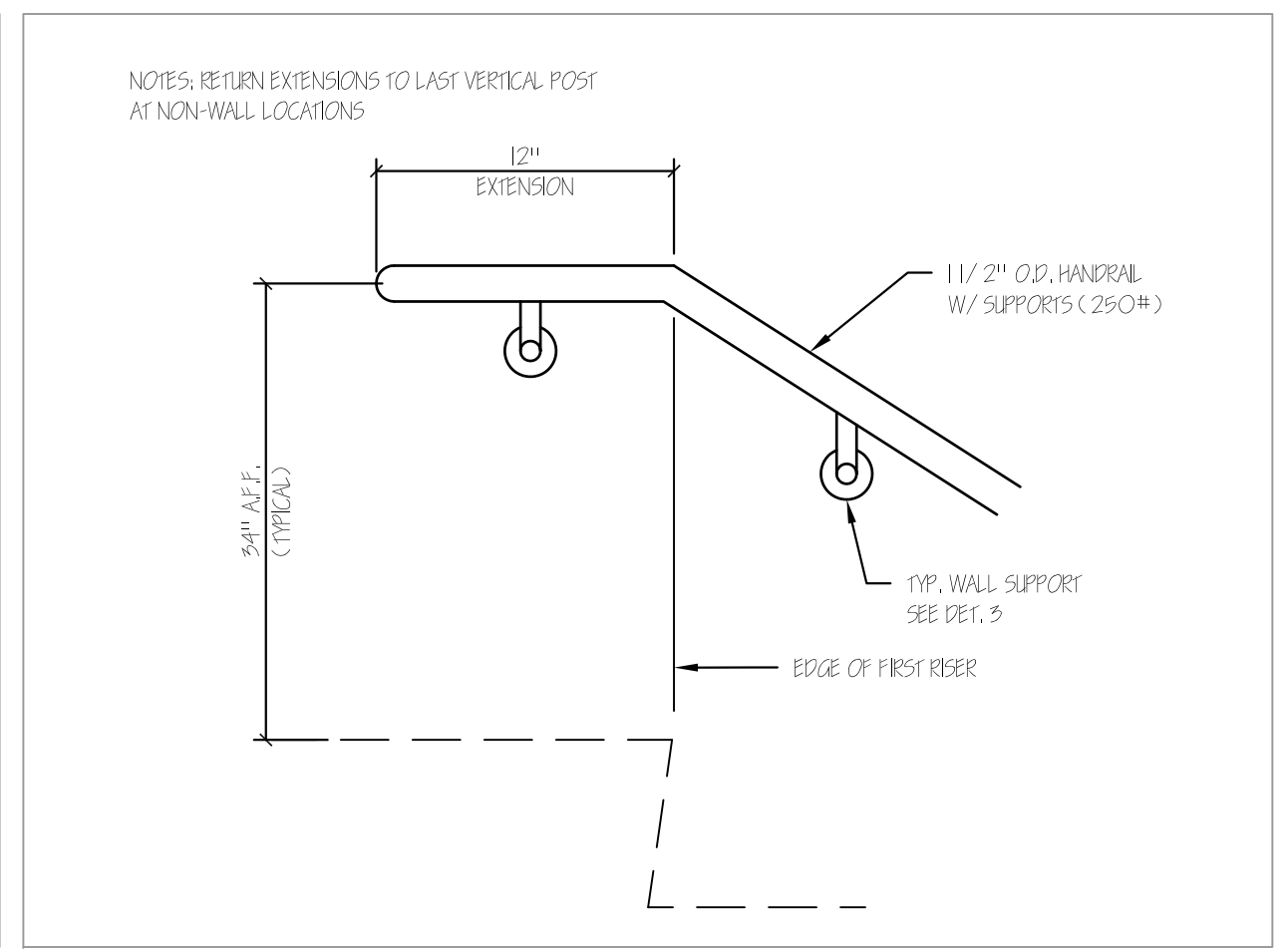

3 TYPICAL WALL HANDRAIL-TOP 3/4" = 1'-0"

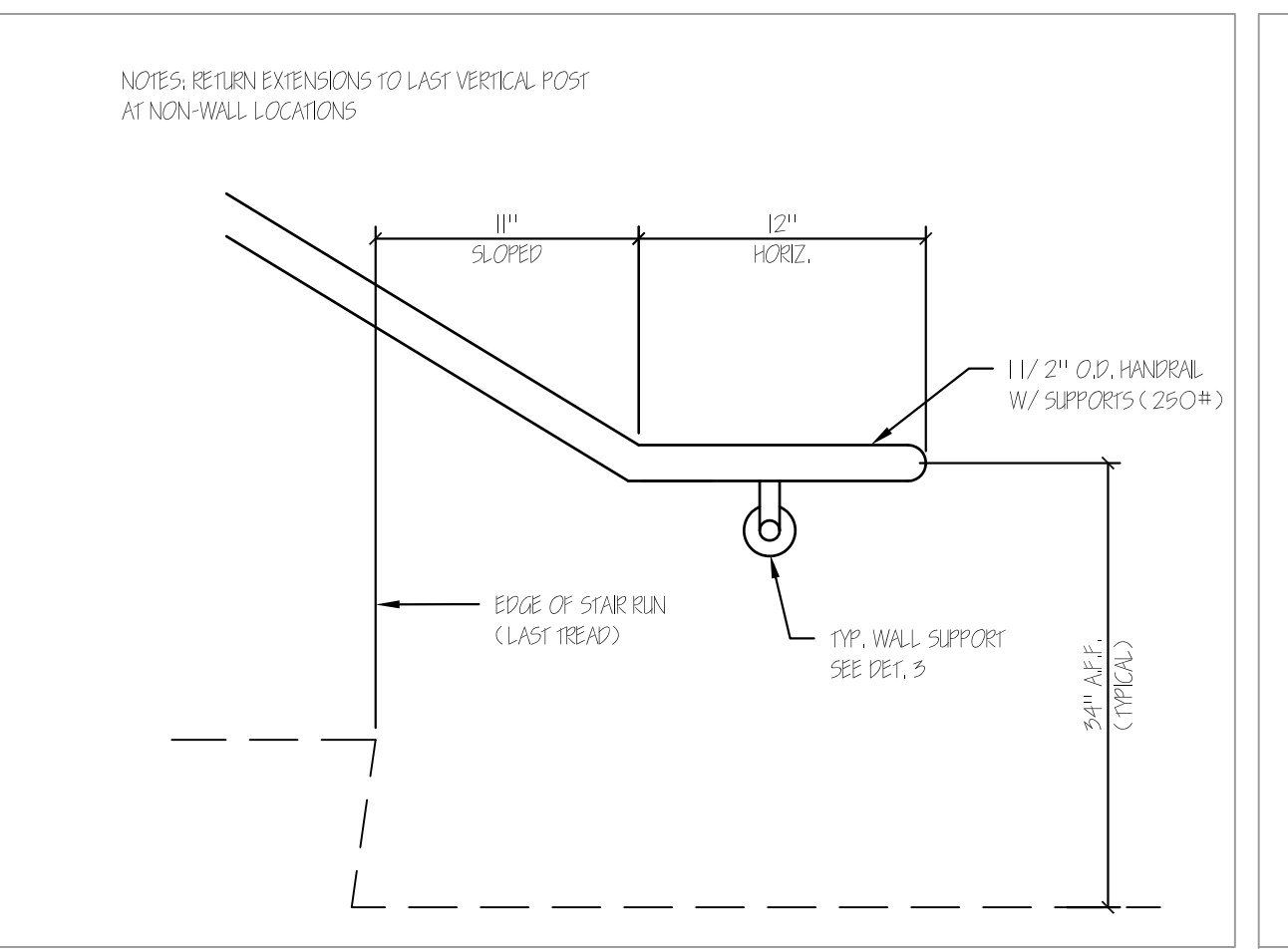

4 TYPICAL WALL HANDRAIL-BOTTOM 3/4" = 1'-0"

NOTE:
CONTRACTOR SHALL VERIFY EXISTING STAIRS HAVE MINIMUM ONE HANDRAIL CONFORMING TO IBC "CURRENT EDITION. SEE DETAIL 1/2/9/4/.

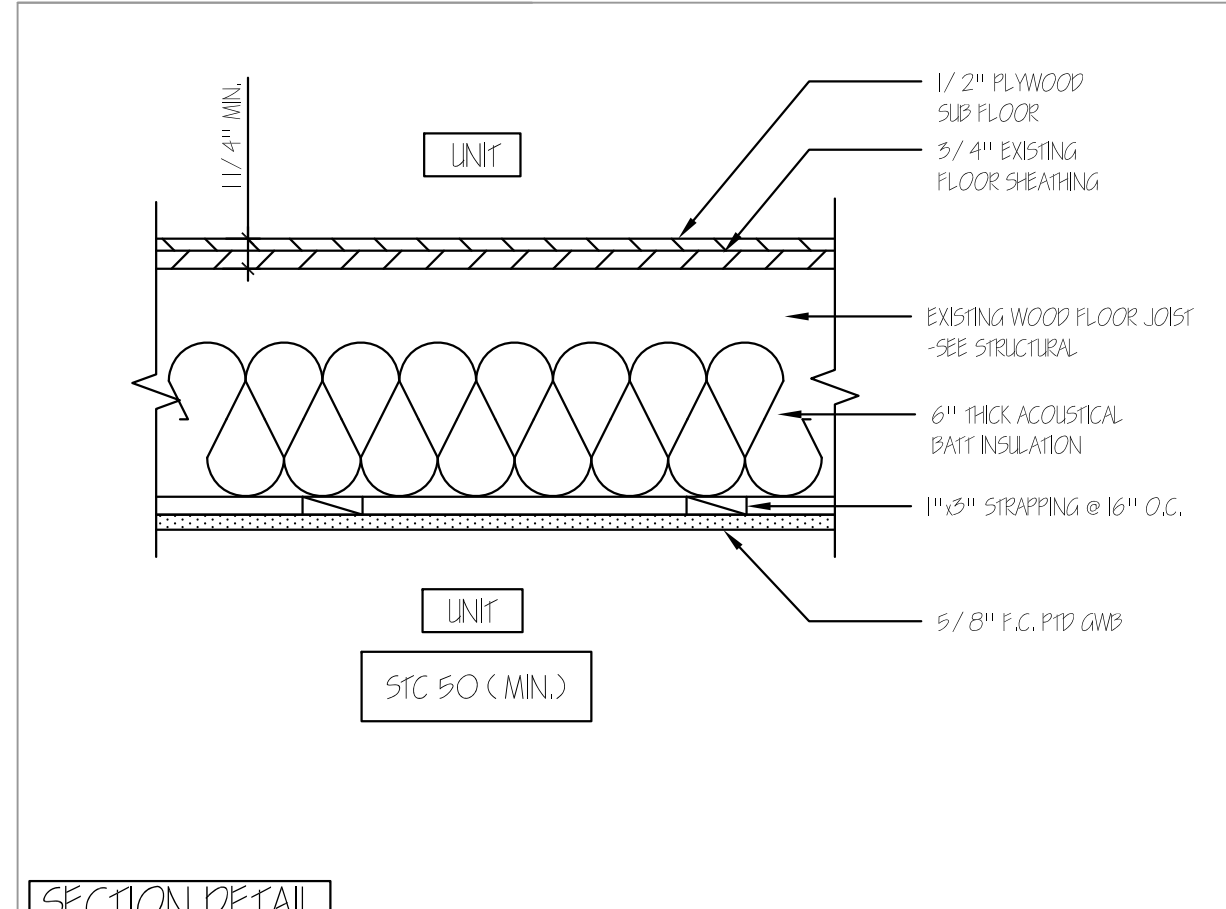

6 1 HR RATED FLOOR/CEILING ASSEMBLY 1 1/2" = 1'-0"

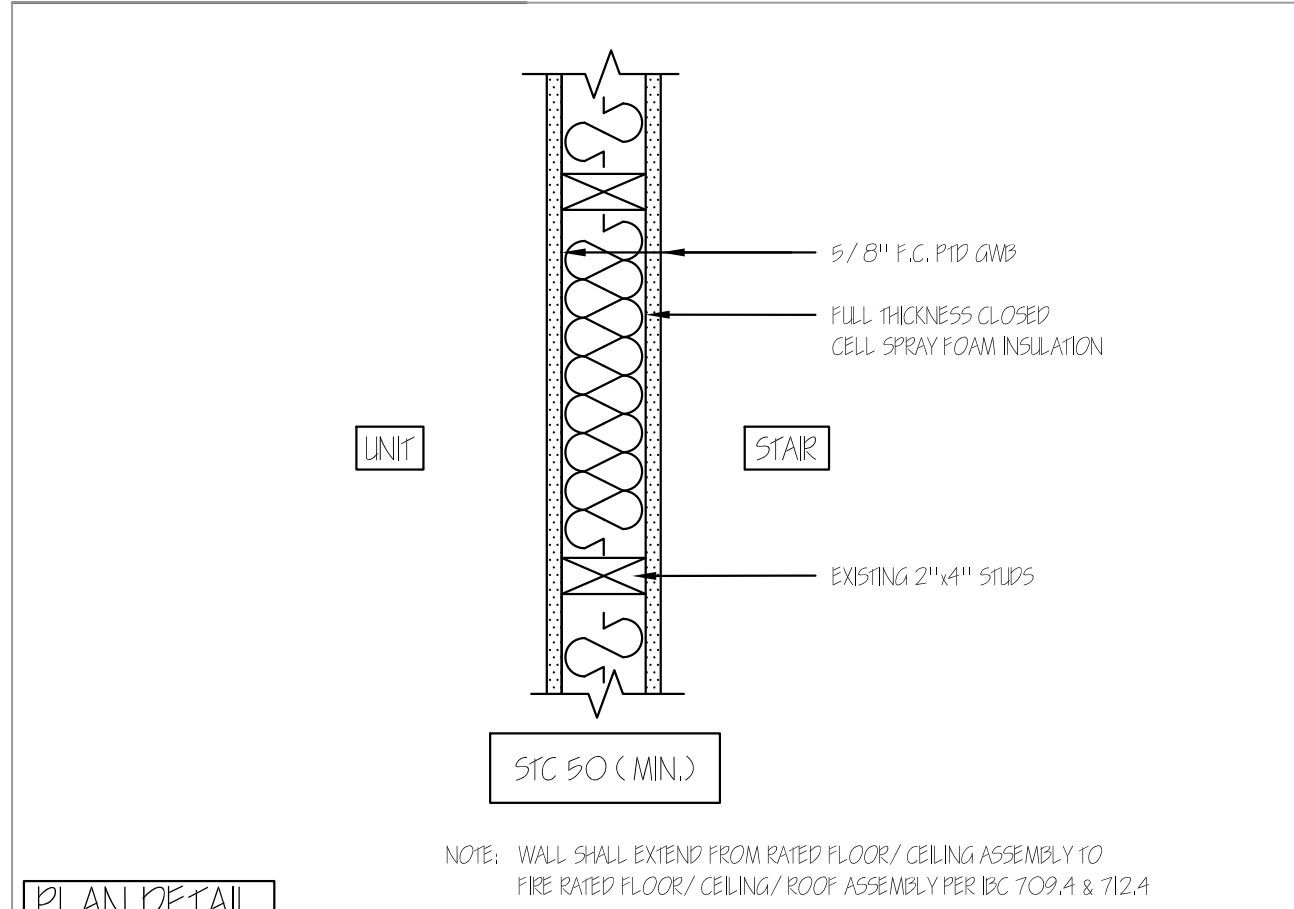

7 1 HR RATED PARTITION AT STAIR 1 1/2" = 1'-0"

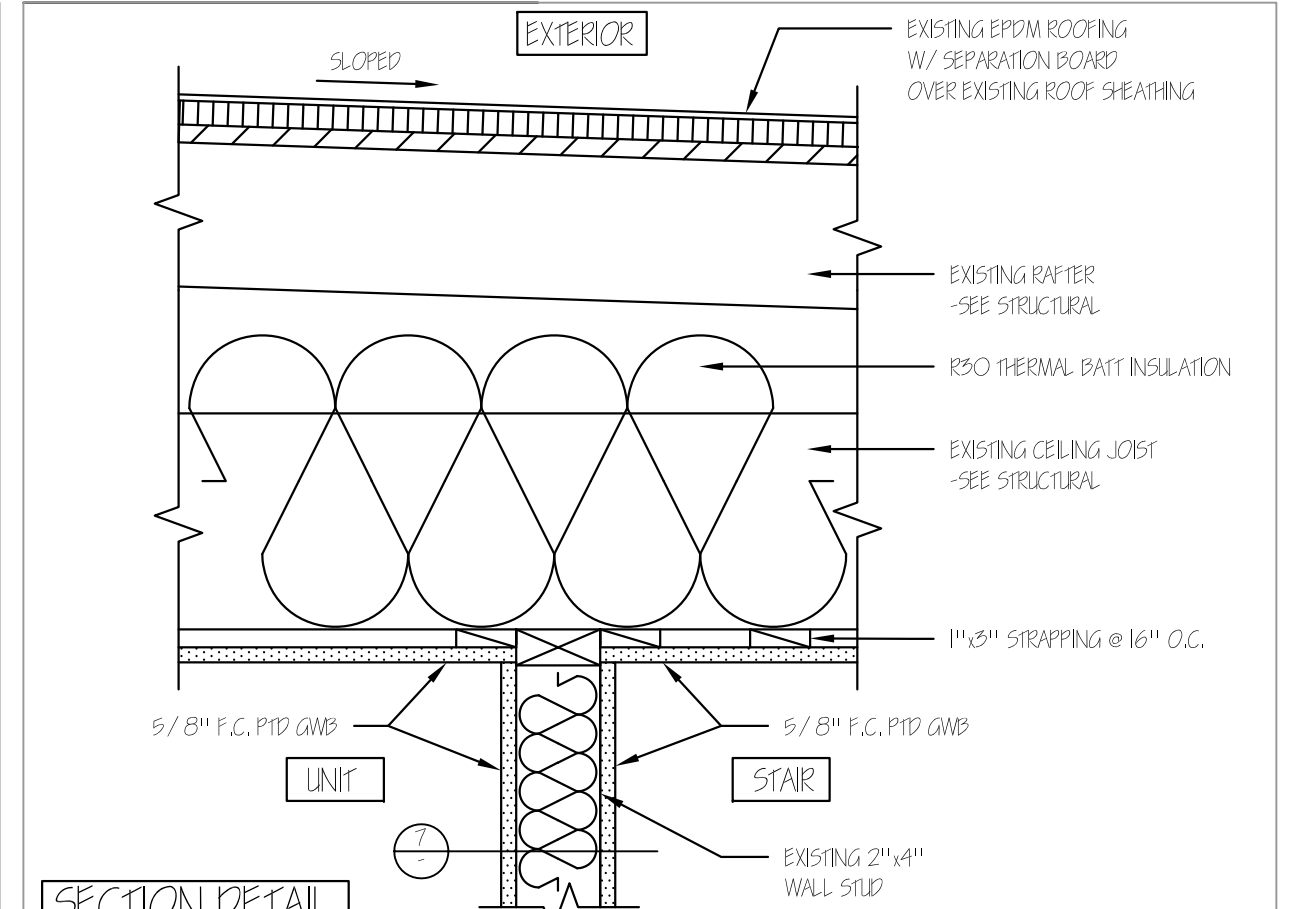

8 1 HR RATED CEILING/ROOF ASSEMBLY 1 1/2" = 1'-0"

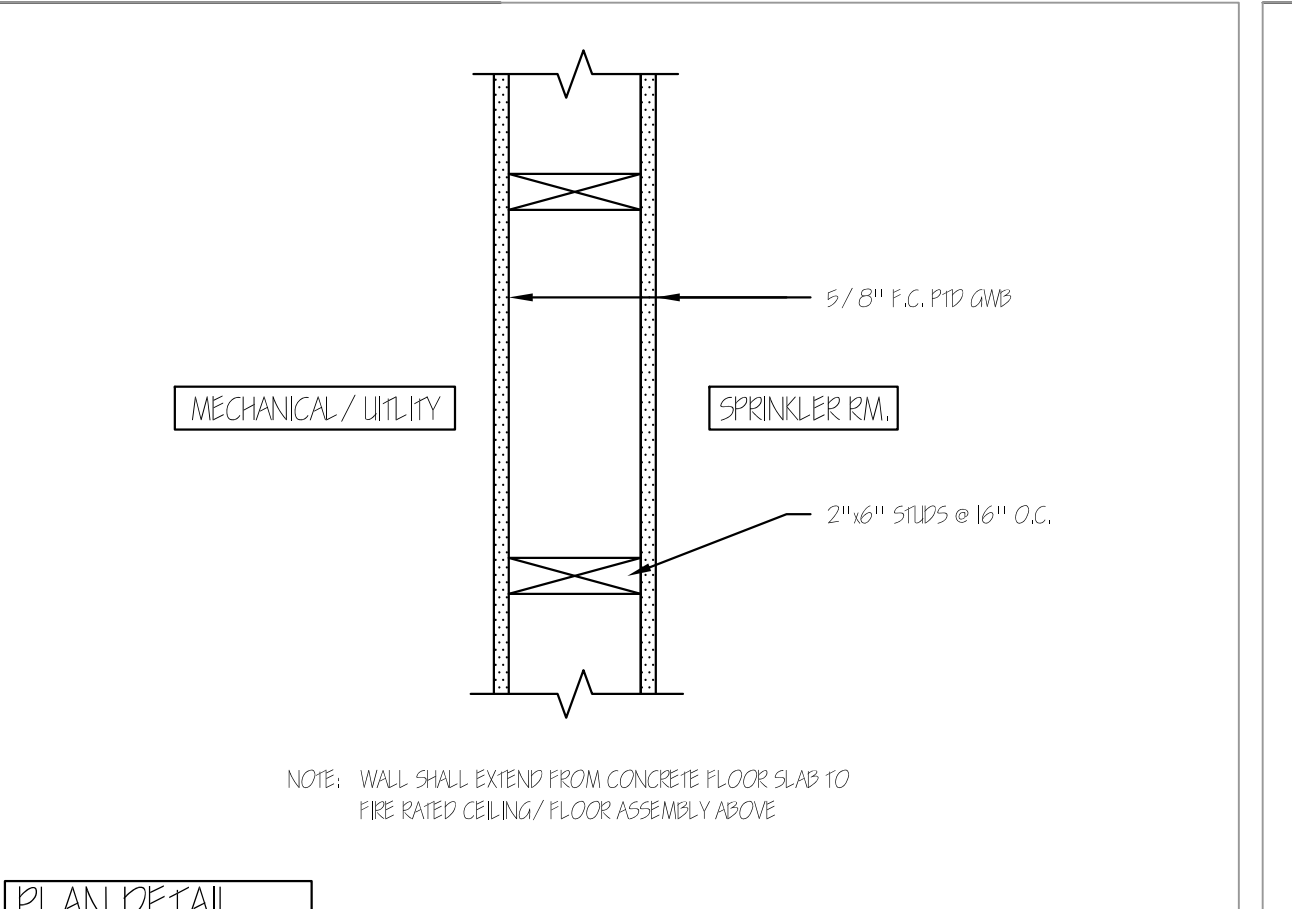

9 1 HR RATED PARTITION WALL 1 1/2" = 1'-0"

NOTE: WALL SHALL EXTEND FROM CONCRETE FLOOR SLAB TO FIRE RATED CEILING / FLOOR ASSEMBLY ABOVE.

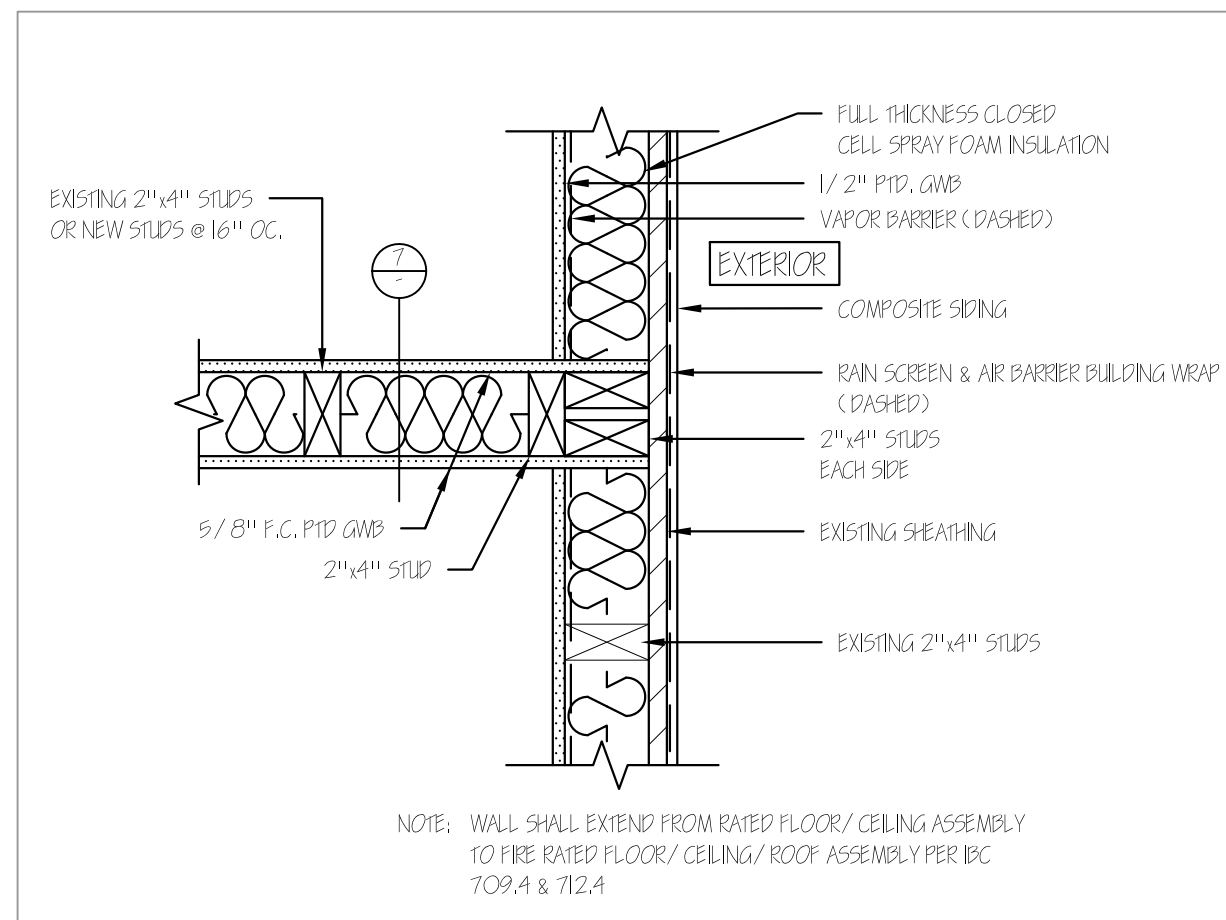

11 1 HR RATED PARTITION @ NON-RATED EXTERIOR WALL ASSEMBLY 1 1/2" = 1'-0"

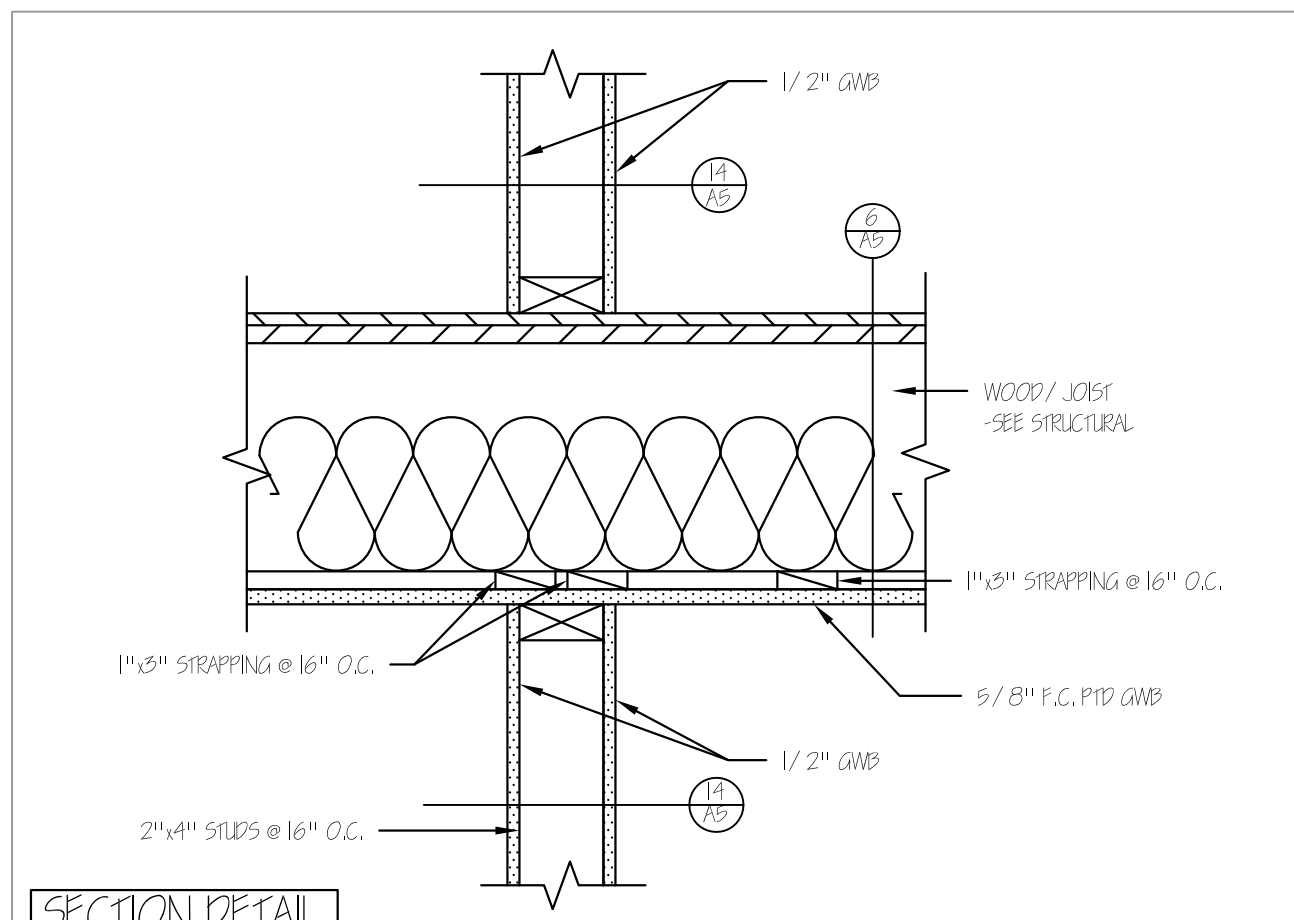

12 NON-RATED PARTITION @ 1 HR FIRE RATED FLOOR/CEILING ASSEMBLY 1 1/2" = 1'-0"

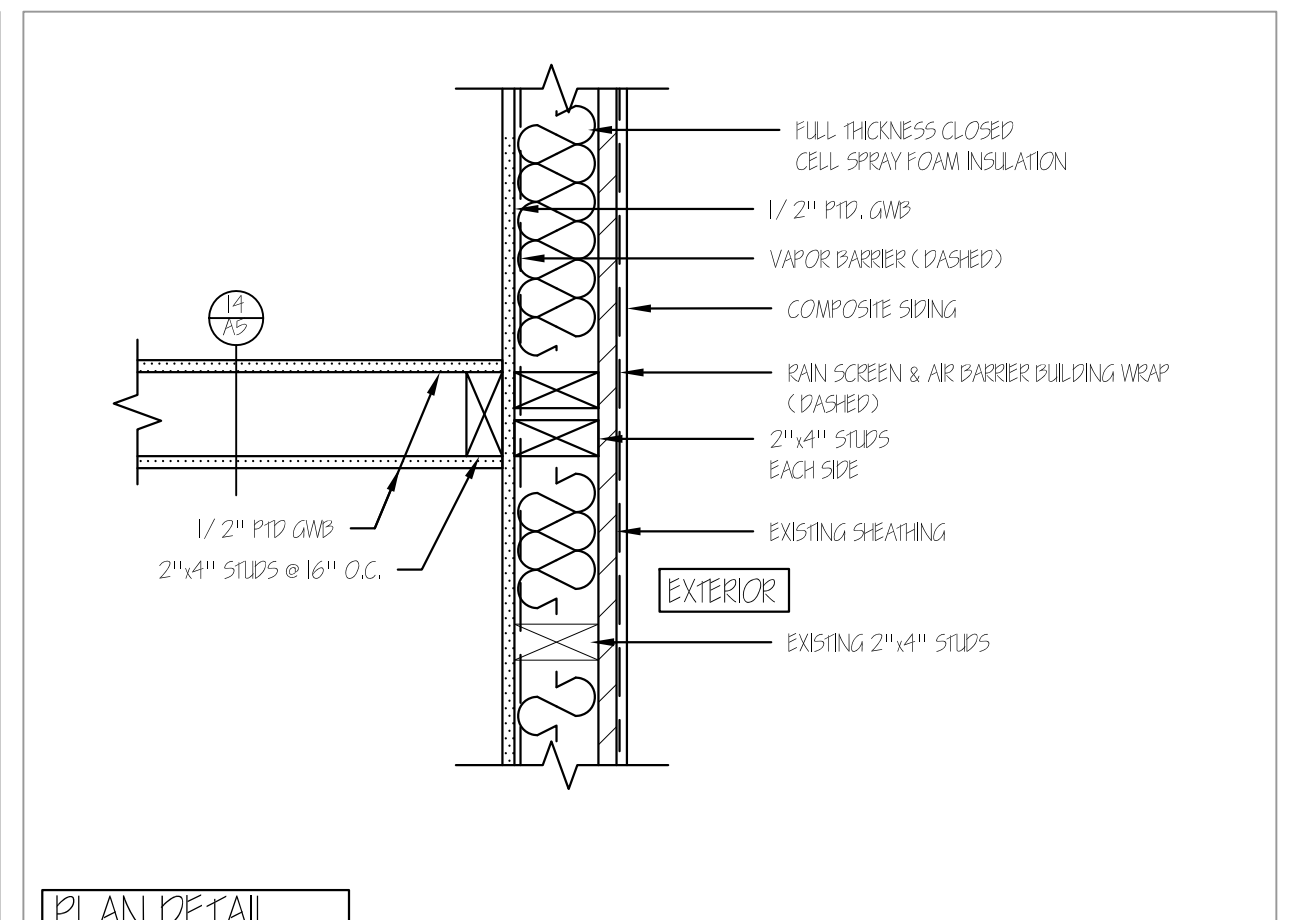

13 NON-RATED PARTITION @ NON-RATED EXTERIOR WALL ASSEMBLY 1 1/2" = 1'-0"

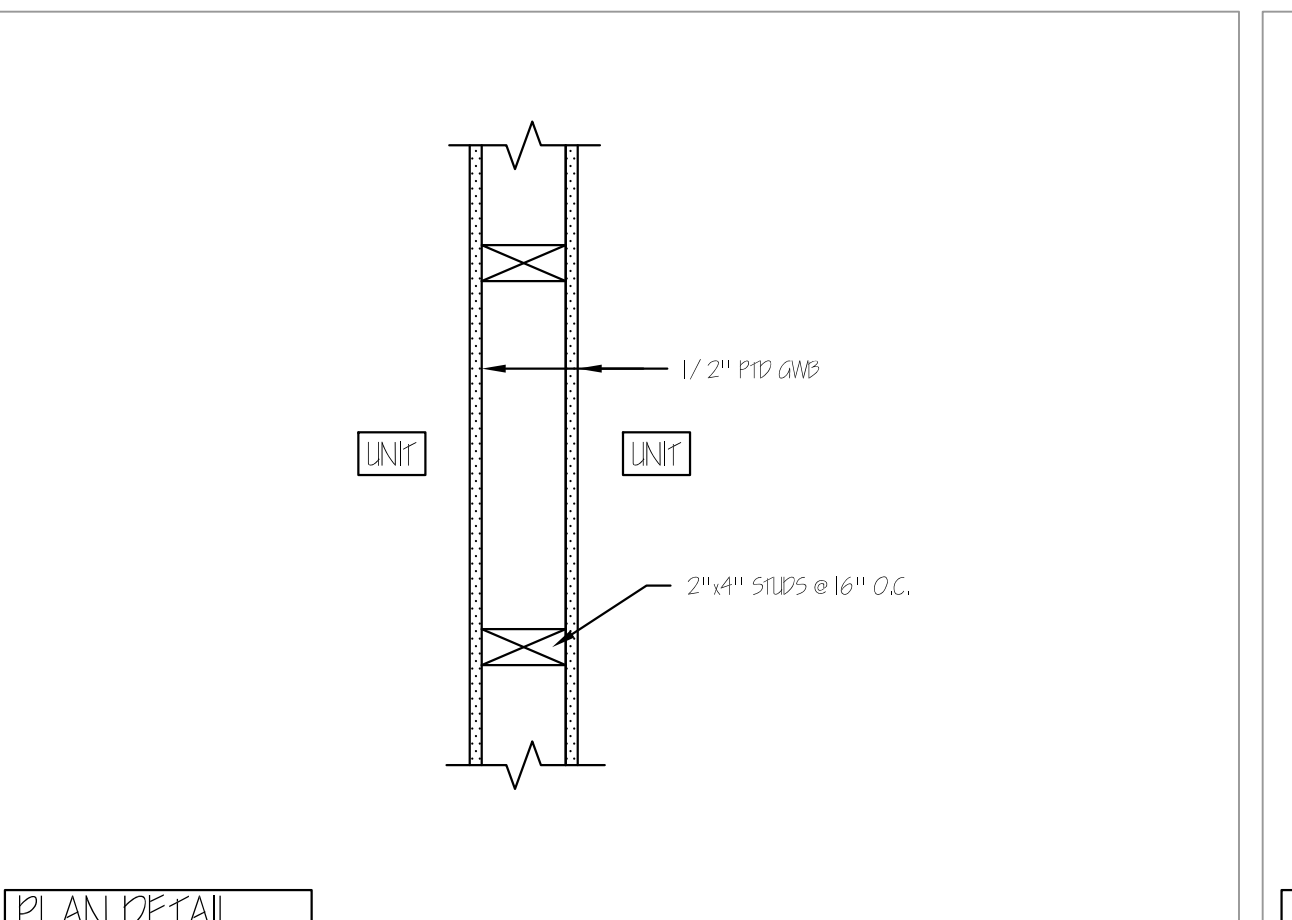

14 NON-RATED INTERIOR PARTITION 1 1/2" = 1'-0"

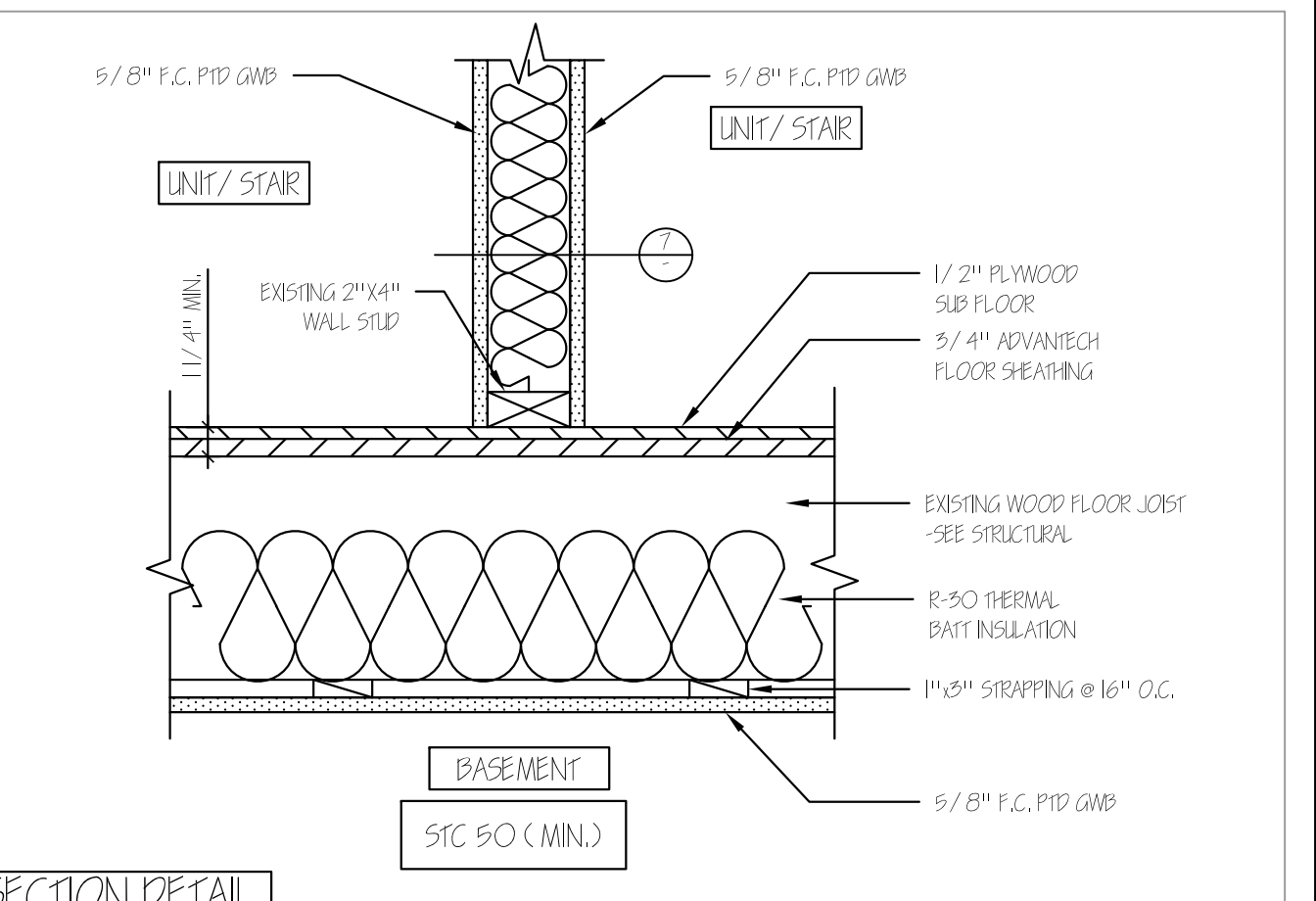

15 1 HR RATED FIRST FLOOR ASSEMBLY 1 1/2" = 1'-0"

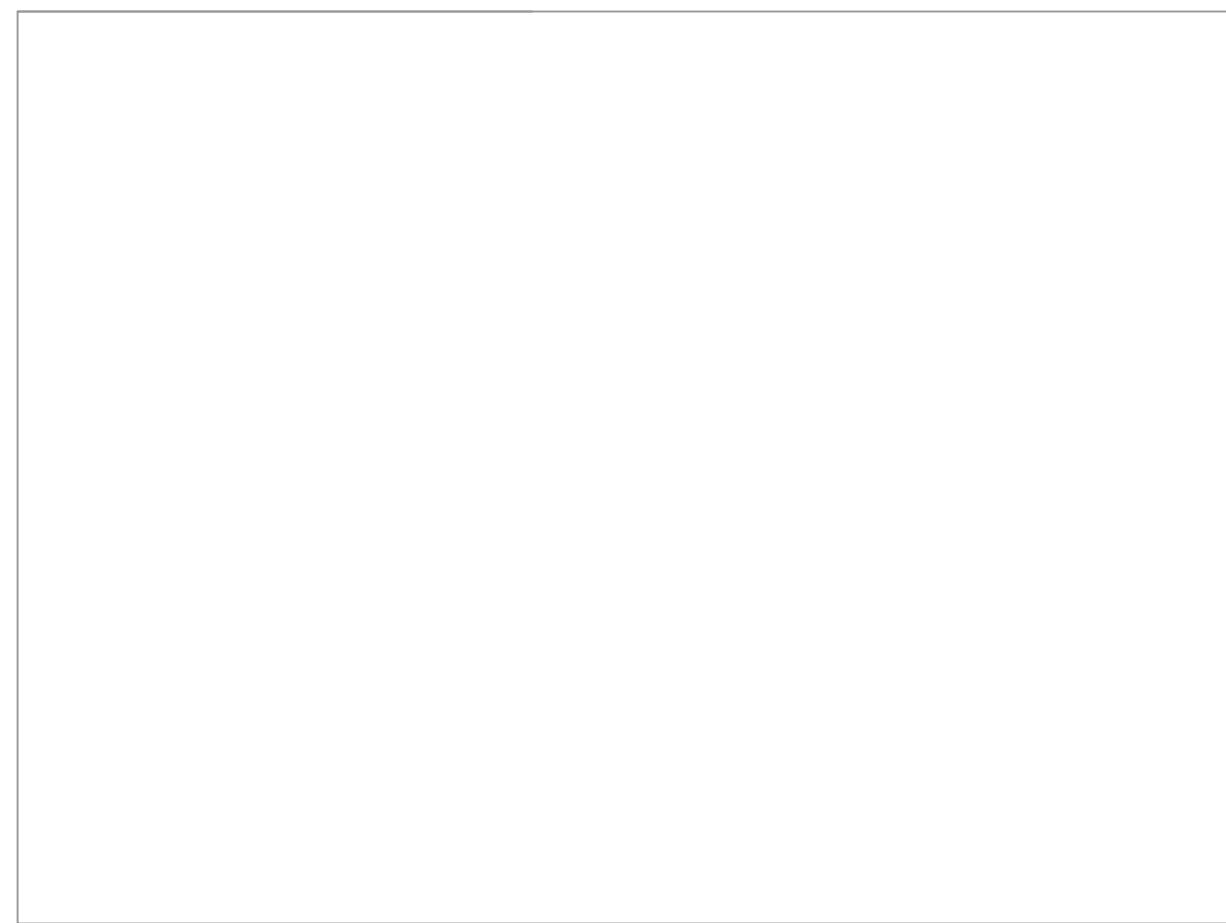

17 EXTERIOR WALL (BRICK) 1 1/2" = 1'-0"

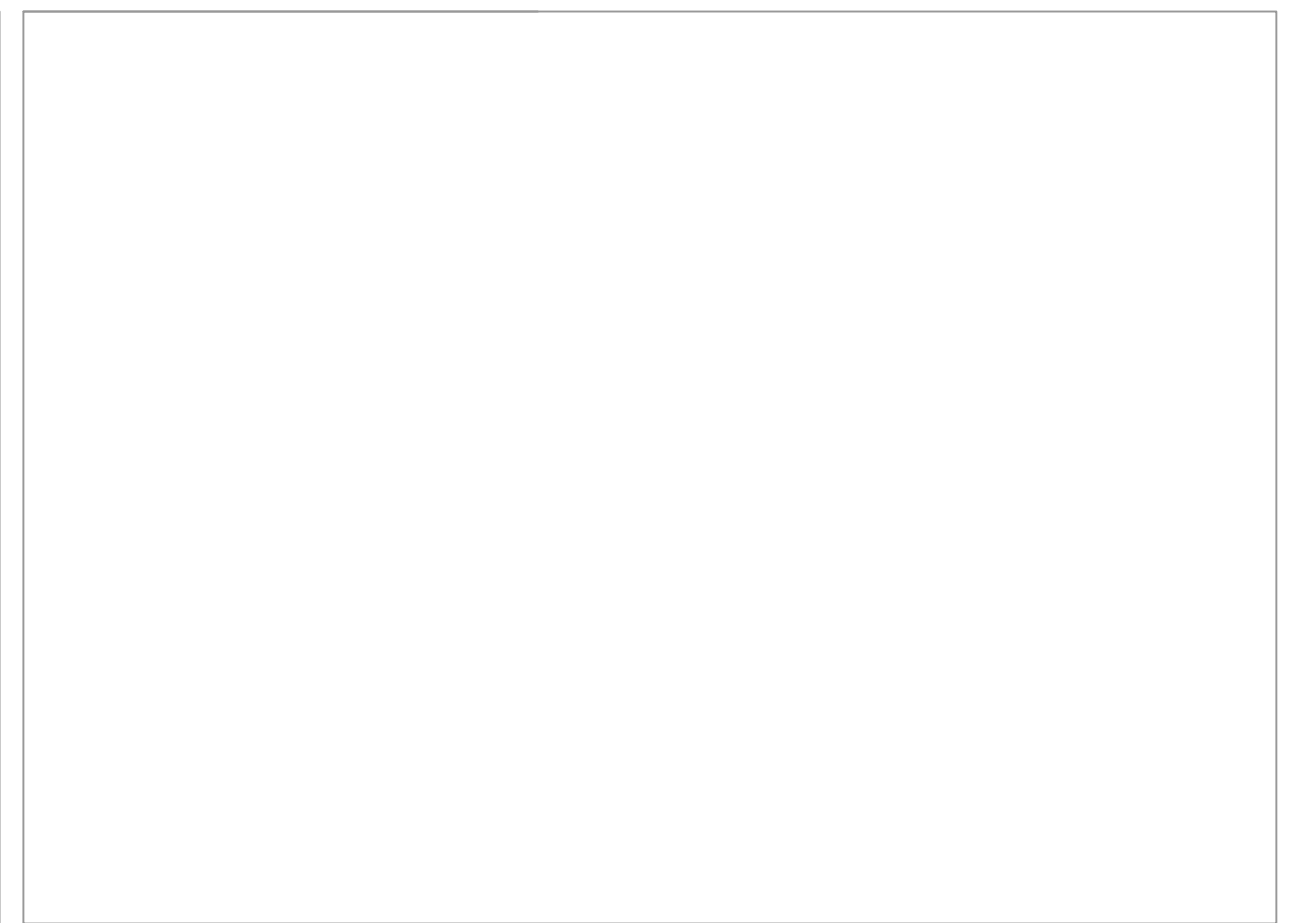

19 NON-RATED EXTERIOR WALL 1 1/2" = 1'-0"

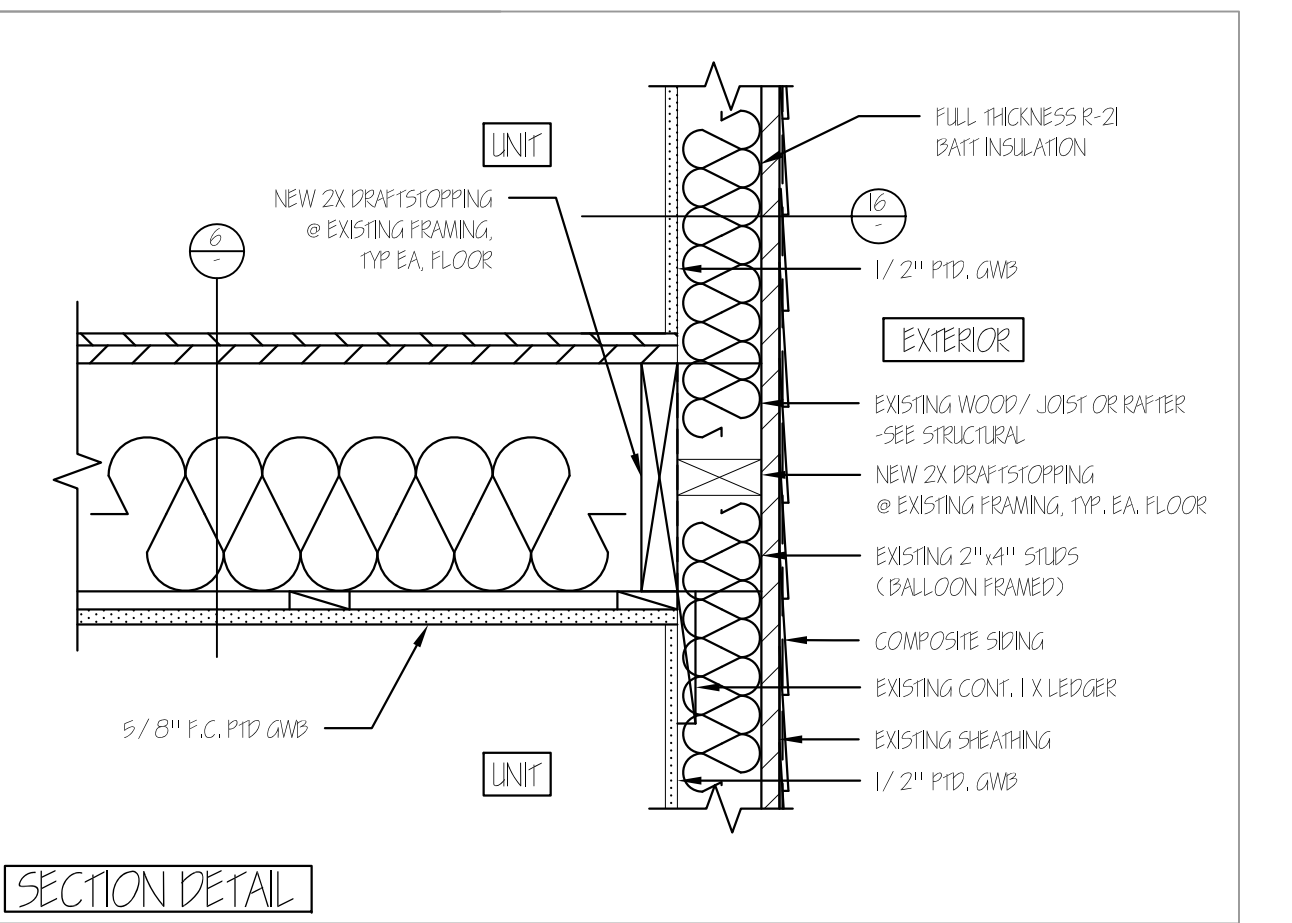

19 NON-RATED EXTERIOR WALL 1 1/2" = 1'-0"

50 WILMOT STREET	
MORIN DRAFTING 318-1177	
50 WILMOT STREET, L.L.C. 477 CONGRESS STREET PORTLAND, MAINE	
SECTIONS & DETAILS	
DRAWN: J. MORIN	SCALE: 1/4" = 1'-0"
DATE: 11-18-2015	PLAN NO:

0 2' 4' 8'
SCALE: 1/4" = 1'-0"

A5