

1 FOUNDATION @ STUD WALL
Scale: 1/2" = 1'-0"

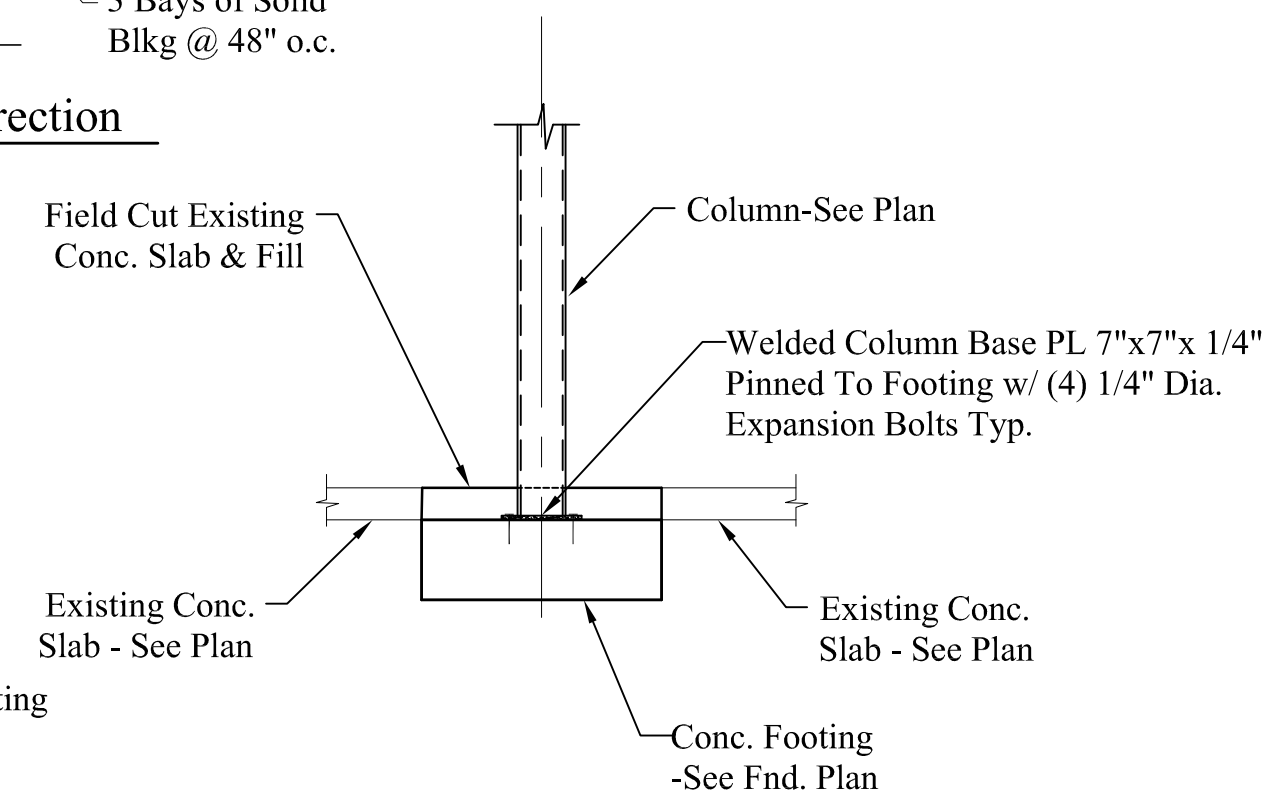

2 INTERIOR COLUMN FOOTING
Scale: 1/2" = 1'-0"

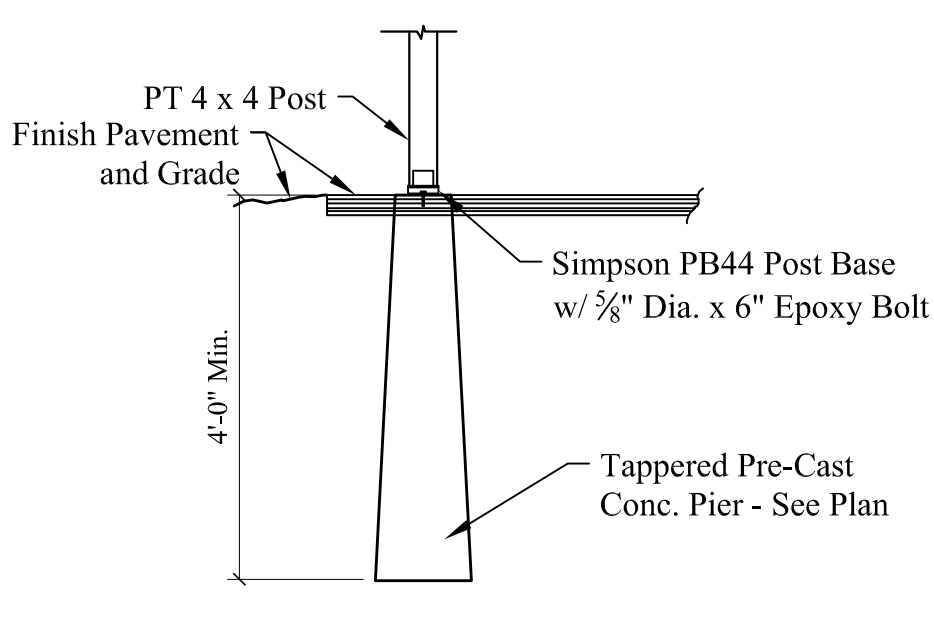

3 POST CONN. @ CONC. PIER
Scale: 1/2" = 1'-0"

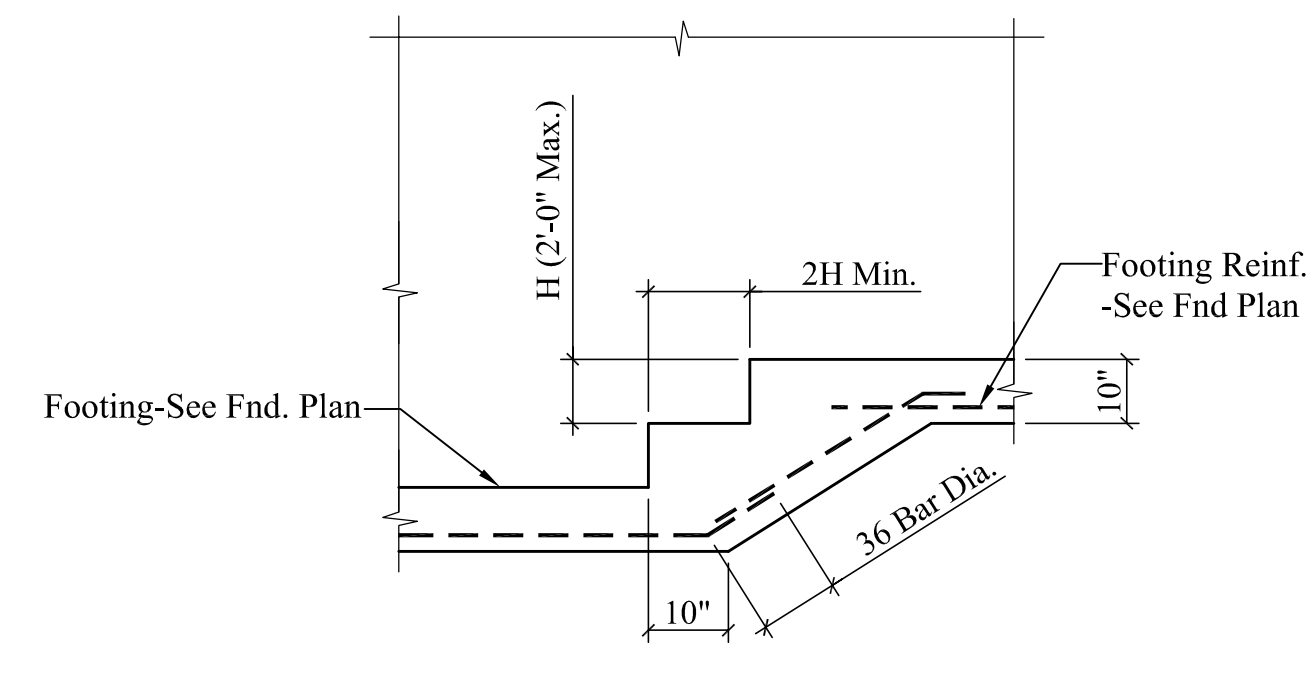

4 TYP STEP FOOTING DETAIL
Scale: 1/2" = 1'-0"

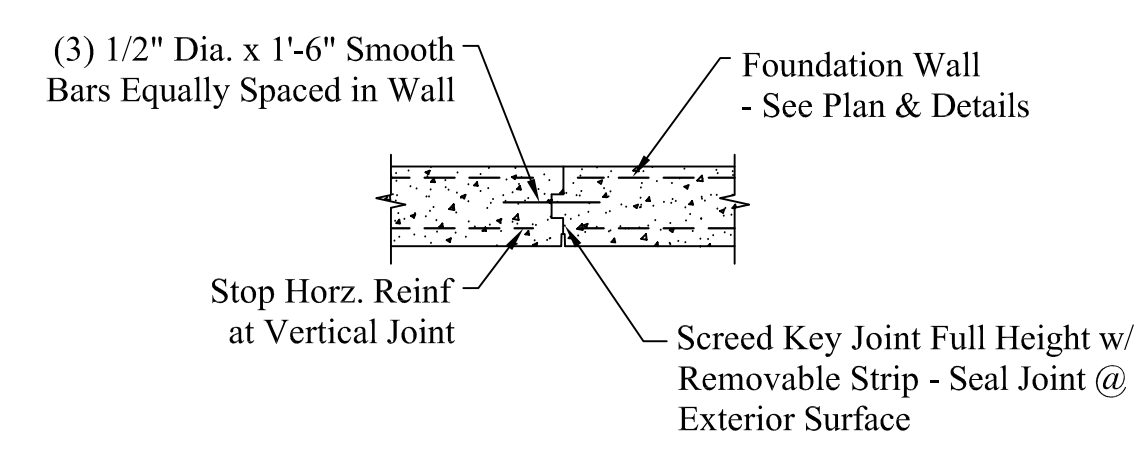

NOTE: Provide joint in walls that exceed 60' in length without cross walls.

JOINT @ FDN WALL

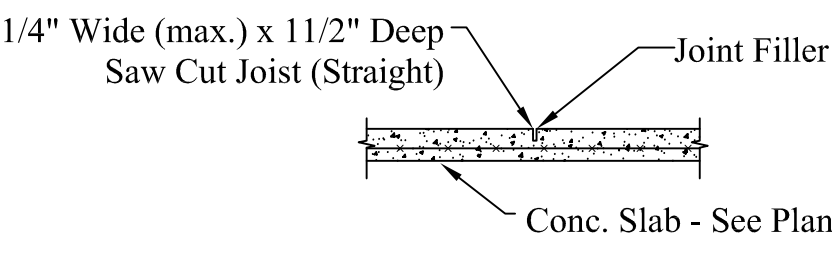

JOINT @ SLAB ON GRADE

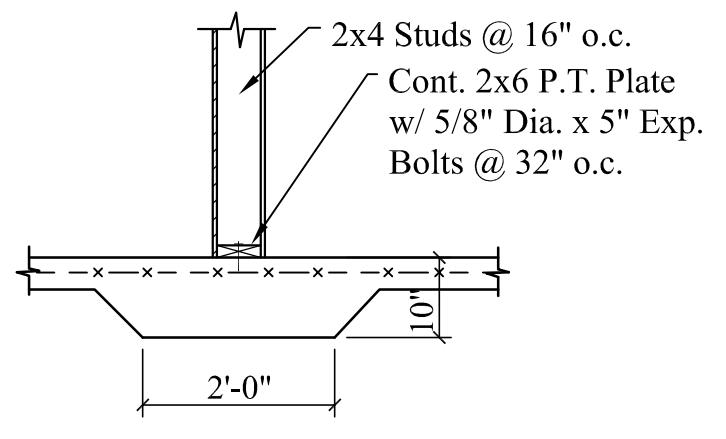

6 TYP. THICKENED SLAB FTG.
Scale: 1/2" = 1'-0"

5 TYP. FLOOR & WALL JOINTS
Scale: 1/2" = 1'-0"

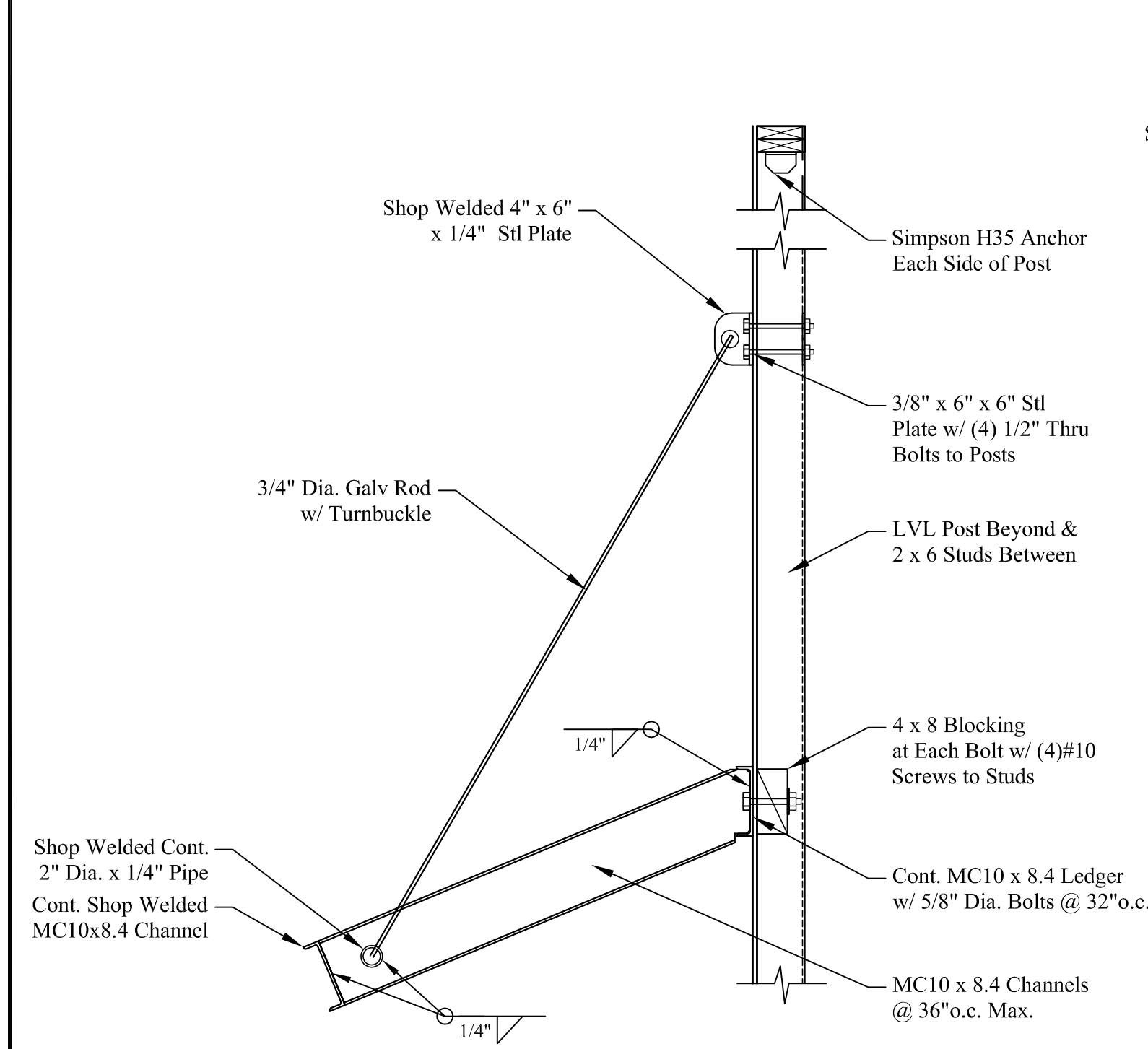

13 HANGING CANOPY ROOF
Scale: 3/4" = 1'-0"

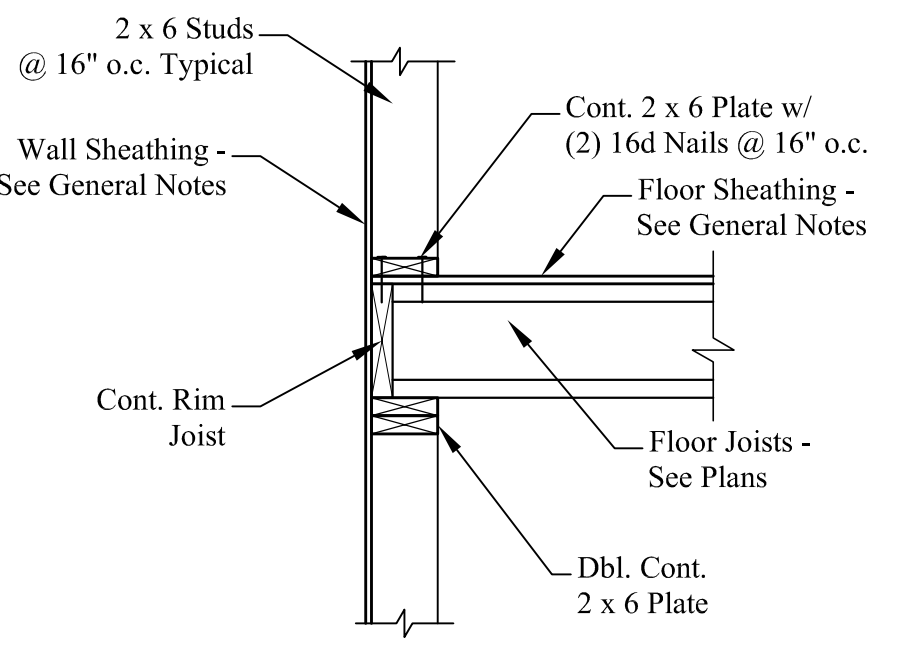

9 FLOOR JOIST @ BRG. WALL
Scale: 3/4" = 1'-0"

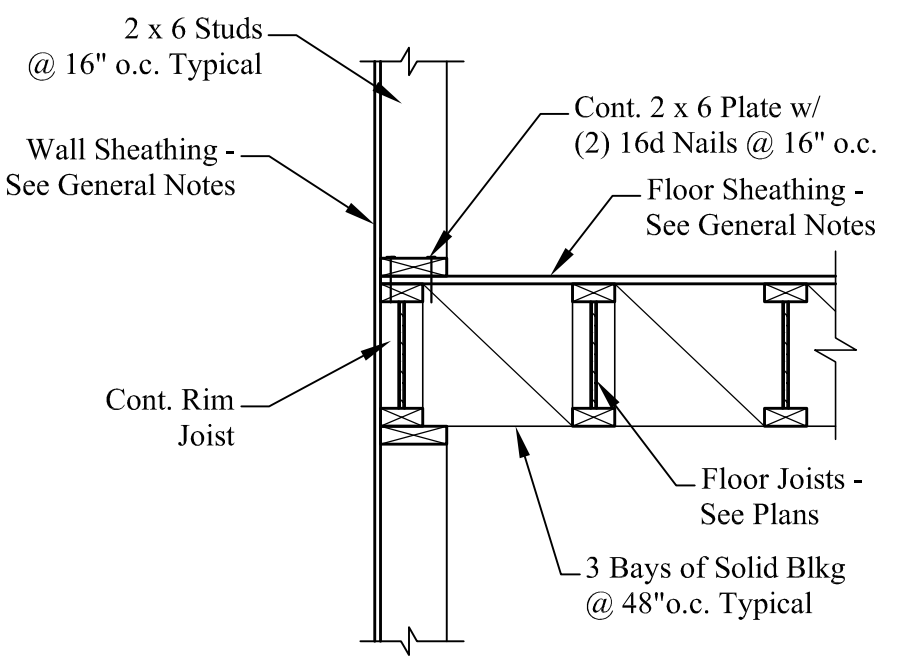

10 FLOOR JOIST @ NON-BRG. WALL
Scale: 3/4" = 1'-0"

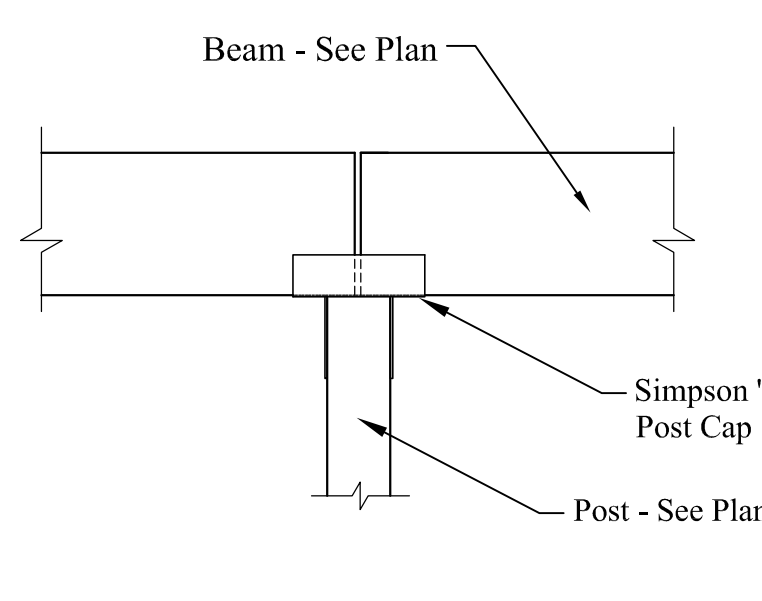

14 WOOD BM. to WOOD POST CONN.
Scale: 3/4" = 1'-0"

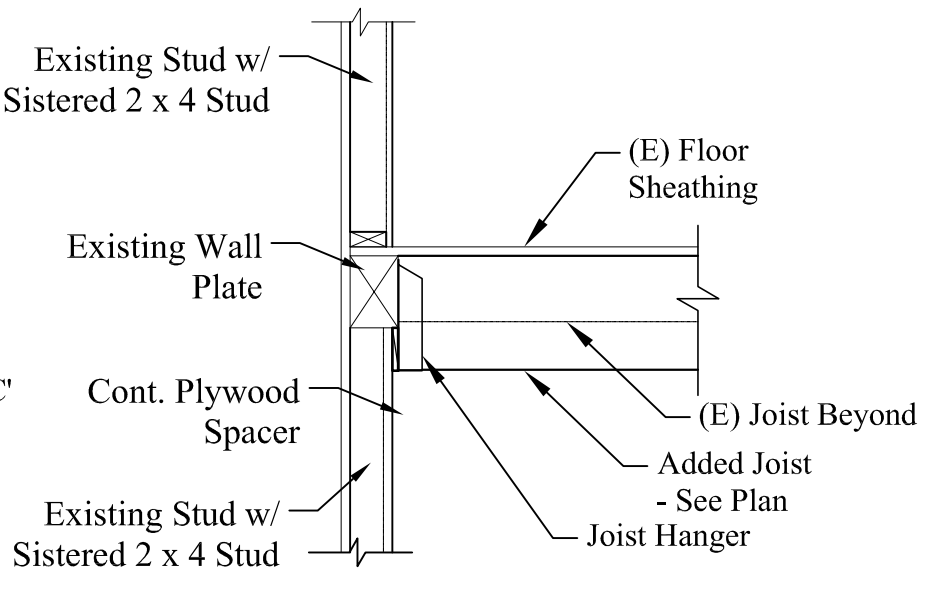

15 FLOOR JOIST @ BRG. WALL
Scale: 3/4" = 1'-0"

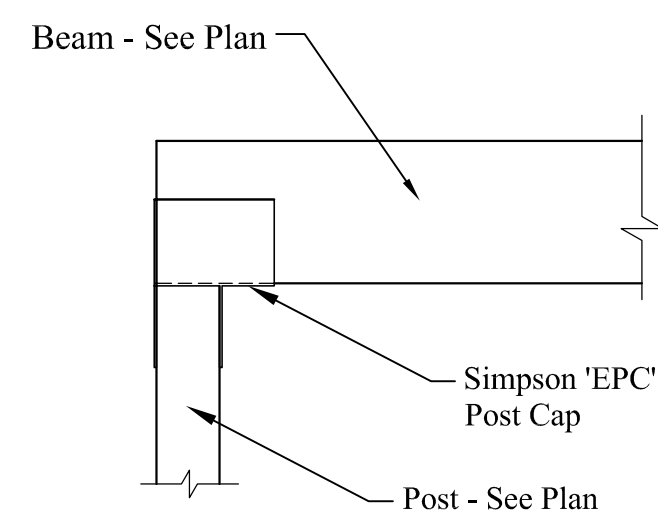

11 WOOD BM. to WOOD POST CONN.
Scale: 3/4" = 1'-0"

STRUCTURAL NOTES:

CODE: Comply with the 2012 International Residential Building Code.

DESIGN LOADS:
Dead Loads: Roof = 15.0 psf., Floor = 10.0 psf.
Live Loads: Roof = 50.0 psf (Plus Drift), 1st Floor = 40.0 psf, 2nd Floor = 35.0 psf.
Wind Load: Building = 28.0 psf

FOUNDATIONS:

- Bear footings on firm, undisturbed dense native soil at 4"-6" minimum below lowest adjacent finish or natural grade, whichever is lower. Step footings to achieve these depths as required.
- Assumed soil bearing pressure = 2,000 psf.
- Place foundation concrete only on clean, firm, dry bearing material.
- Engineer shall be notified if stone ledge or marine clay is found during excavation.
- Install 4" dia. perforated drain tile (rotate perforations to top of pipe) on exterior and interior of footing perimeter. Wrap all drain tile in filter fabric and encase with 3/4" crushed stone around entire pipe. Create a positive drain to atmosphere or dry well with drainage away from structure. Provide (2) stubs through slab for possible use in radon mitigation system. See contractor for mitigation system requirements. Contractor shall be responsible for any additional drainage requirements, such as sump pumps etc.
- All foundation wall exteriors shall be coated with dampproofing per manufacturer's spec. Dampproofing shall not be visible above final grade.
- See architectural drawings for additional information not shown.

CONCRETE:

- Concrete regular weight (144 pcf) with Type II cement per ASTM C150, aggregate per ASTM C33, and potable water. No fly-ash permitted in floor slab. Aggregate size = 1" maximum for footings and slab. Minimum compressive strength = 3000 psi for foundations and slab on grade and 4,000 psi for exterior slabs and sidewalks.
- Saw cuts for floor slab control joints (CJ) shall be made as soon as the slab can support the weight of the saw, but no more than 12 hours after placing concrete. Max. 24 sq. ft. of per saw cut area.
- Pitch all garage floor slabs 1/4" ft. toward over head door.
- Slabs shall bear on 2" rigid insulation with 8" deep compacted crushed stone below.

REINFORCING:

- ASTM A 615-S1, Grade 60 except #2 and #3 bars ASTM A615-S1: Grade 40.
- Lap splices in concrete: 42 bar diameters.
- Provide bent corner reinforcing to match and lap with horizontal reinforcing at corners and intersections of walls, and footings.
- Reinforcing shall be placed with 3" clearance at all surfaces.

STEEL:

- Rolled sections and plates: ASTM A-36, Fy = 36 ksi.
- Steel Lally Columns: ASTM A513, Fy = 32 ksi. 16 gage steel filled w/ 3,000 psi concrete.
- Steel Pipe Column: (not lally columns) ASTM A-36, Fy = 36 ksi.
- Bolts and plain anchors: ASTM A 307.
- Submit shop drawings. Fabricate after Engineers review.

WOOD:

- General:
 - Each piece of lumber shall be "S-DRY" and bear the grade stamp of a grading rules agency approved by the American Lumber Standards Committee.
 - Double up studs at jacks and under beams.
 - Do not notch or drill joists, beams or load bearing studs without approval.
- Connections:
 - Nail roof plywood with 8d common at 6" o.c. at all edges and boundary members and 10" o.c. at intermediate supports.
 - Glue floor plywood to all framing members and nail with 8d common at 6" o.c. at all plywood edges and boundary members and 10" o.c. at intermediate supports.
 - Nail wall plywood with 10d common nails at 6" o.c. at all edges and boundary members and 12" o.c. at intermediate supports.
- Structural Sawn Lumber:
 - 2 x 6 thru 2 x 14 joists: Spruce Pine Fir No. 2 with Fb (repetitive) = 1200 p.s.i.
 - Studs: Spruce Pine Fir No. 2 with Fb (repetitive) = 1200 p.s.i.
- Laminated Veneer Lumber (LVL): Fb = 2800 psi, Fv = 285 psi, E = 2,000 ksi
- Plywood:
 - Roof Sheathing: C-D INT-APA (PSI-94) with exterior glue; 5/8" with Identification Index 48/24. Lay up with face grain perpendicular to supports. Stagger joints. Each plywood piece to be continuous over a minimum of two spans with a minimum width of 1'-0" unless blocking is provided at all joints.
 - Sub-flooring: C-D INT-APA (PSI-94) with exterior glue; 3/4" with Identification Index 48/24. lay up with face grain perpendicular to supports. Stagger joints. Each plywood piece to be continuous over a minimum of two spans with a minimum width of 1'-0" unless blocking is provided at all joints.
 - Wall Sheathing: C-D INT-APA (PSI-74) with exterior glue, 1/2" with Identification Index 24/0. All panel edges backed with 2" nominal or wider framing.
- Light Metal Plate Connected Wood Trusses:
 - Design, fabricate, transport and erect per Truss Plate Institute Standards TPI-18 and BWT76.
 - Design for loads, in addition to member weights, as given under "DESIGN LOADS" above.
 - Submit design calculations and shop drawings. Fabricate after the Engineer's review. Include wood grades to be used.
 - All permanent and temporary bracing and fastening at bearings by truss manufacturer.
 - Comply with "SUPPLEMENTARY NOTES" below.

SUPPLEMENTARY NOTES:

- Verify all dimensions and conditions with architectural drawings prior to starting work. Notify the Engineer of any discrepancies or inconsistencies.
- Provide all necessary temporary bracing, shoring, guying or other means to avoid excessive stresses and to hold structural elements in place during construction.

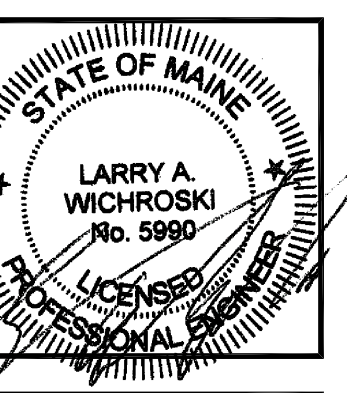

DESIGNED BY:
Larry A. Wichroski, P.E.
DRAWN BY:
LAW
JOB #: 04215
DATE: 01-25-2016

NO.	REVISIONS